



- (51) **International Patent Classification:**  
*D06F 58/04* (2006.01) *D06F 58/06* (2006.01)
- (21) **International Application Number:**  
PCT/EP2012/071617
- (22) **International Filing Date:**  
31 October 2012 (31.10.2012)
- (25) **Filing Language:** English
- (26) **Publication Language:** English
- (30) **Priority Data:**  
A 2011/11061 4 November 2011 (04.11.2011) TR
- (71) **Applicant (for all designated States except US):** ARCE-  
LIK ANONIM SIRKETI [TR/TR]; E5 Ankara Asfalti  
Uzeri, Tuzla, 34950 Istanbul (TR).
- (72) **Inventors; and**
- (71) **Applicants (for US only):** KOSE, Egemen [TR/TR]; E5  
Ankara Asfalti Uzeri, Tuzla, 34950 Istanbul (TR). ABDIK,  
Bora [TR/TR]; E5 Ankara Asfalti Uzeri, Tuzla, 34950  
Istanbul (TR). DEMIRHAN, Dogan [TR/TR]; E5 Ankara  
Asfalti Uzeri, Tuzla, 34950 Istanbul (TR). GOKTAS,  
Murat [TR/TR]; E5 Ankara Asfalti Uzeri, Tuzla, 34950  
Istanbul (TR).

(81) **Designated States (unless otherwise indicated, for every kind of national protection available):** AE, AG, AL, AM, AO, AT, AU, AZ, BA, BB, BG, BH, BN, BR, BW, BY, BZ, CA, CH, CL, CN, CO, CR, CU, CZ, DE, DK, DM, DO, DZ, EC, EE, EG, ES, FI, GB, GD, GE, GH, GM, GT, HN, HR, HU, ID, IL, IN, IS, JP, KE, KG, KM, KN, KP, KR, KZ, LA, LC, LK, LR, LS, LT, LU, LY, MA, MD, ME, MG, MK, MN, MW, MX, MY, MZ, NA, NG, NI, NO, NZ, OM, PA, PE, PG, PH, PL, PT, QA, RO, RS, RU, RW, SC, SD, SE, SG, SK, SL, SM, ST, SV, SY, TH, TJ, TM, TN, TR, TT, TZ, UA, UG, US, UZ, VC, VN, ZA, ZM, ZW.

(84) **Designated States (unless otherwise indicated, for every kind of regional protection available):** ARIPO (BW, GH, GM, KE, LR, LS, MW, MZ, NA, RW, SD, SL, SZ, TZ, UG, ZM, ZW), Eurasian (AM, AZ, BY, KG, KZ, RU, TJ, TM), European (AL, AT, BE, BG, CH, CY, CZ, DE, DK, EE, ES, FI, FR, GB, GR, HR, HU, IE, IS, IT, LT, LU, LV, MC, MK, MT, NL, NO, PL, PT, RO, RS, SE, SI, SK, SM, TR), OAPI (BF, BJ, CF, CG, CI, CM, GA, GN, GQ, GW, ML, MR, NE, SN, TD, TG).

**Published:**

— with international search report (Art. 21(3))

(54) **Title:** A LAUNDRY DRYER COMPRISING A TRANSPORTATION SAFETY MEMBER

Figure 1

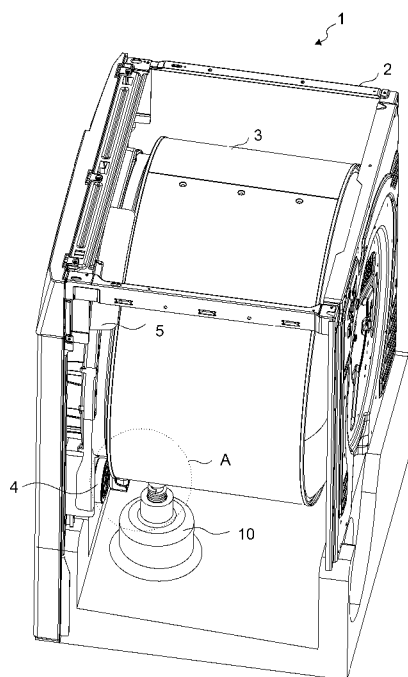

(57) **Abstract:** The present invention relates to a laundry dryer (1) comprising a body (2), a drum (3) which rotates around the horizontal axis and wherein items to be dried are placed, more than one roller (4) whereon the drum (3) is seated and which supports the drum (3) by rotating around their own axes by the movement of the drum (3) during the drying process, a frame (5) whereon the rollers (4) are rotatably mounted and a transportation safety member (6) having two positions.

**Description****A LAUNDRY DRYER COMPRISING A TRANSPORTATION SAFETY MEMBER**

- [0001] The present invention relates to a laundry dryer comprising a transportation safety member.
- [0002] In laundry dryers, the laundry to be dried is loaded into a drum. The drying process is realized by this drum being driven and rotated by a motor. In the state of the art, a sliding or roller bearing system is used for drums to be borne from their front side. In laundry dryers wherein the roller system is preferred, at the moments of falling and impact that can occur during transportation, deformations occur depending on the impact on the drum areas wherein the rollers are contacted.
- [0003] In the state of the art European Patent No. EP1702097, a washer/dryer is explained wherein a fixing mechanism is utilized to temporarily fasten the washing tank, wherein the drum moves, to the body during transportation.
- [0004] The aim of the present invention is the realization of a laundry dryer comprising a transportation safety member which prevents the drum from being damaged during transportation.
- [0005] The laundry dryer realized in order to attain the aim of the present invention, explicated in the first claim and the respective claims thereof, comprises a body, a drum, more than one roller which provides the drum to be borne, and a frame whereon the rollers rotating by means of the drum are mounted. The laundry dryer of the present invention comprises a transportation safety member having two positions. When the laundry dryer is to be transported, the transportation safety member is changed from the first position wherein it does not contact the drum to the second position wherein it separates the drum from the rollers by contacting the drum.
- [0006] In an embodiment of the present invention, the transportation safety member pushes the drum upwards. Thus, the drum is separated from the rollers whereon it is seated and the drum is secured against possible impacts it may be subjected to in cases such as storing and transporting the laundry dryer.
- [0007] In an embodiment of the present invention, the transportation safety

member comprises a shaft with a toothed part thereon, a resting member which is located at the shaft end facing the drum, and a head allowing the screwing process of the shaft to be performed by being rotated inside the guide. Thus, the control of the transportation safety member is easily realized.

- [0008] In a derivative of this embodiment, the resting member has the same shape as the portion it touches the drum. Thus, the transportation safety member can lift the drum without deforming it.
- [0009] In a derivative of this embodiment, the transportation safety member has a resting member produced from elastomeric material. Thus, the production cost of the resting member decreases.
- [0010] In an embodiment of the present invention, the laundry dryer comprises a guide having a screw hole wherein the transportation safety member moves. Thus, since the transportation safety member moves inside the guide at intervals of a screw pitch, the force to be applied onto the drum is provided to be controllable.
- [0011] In a derivative of this embodiment, during its movement inside the guide, the head of the transportation safety member bears against the stopper after the drum is separated from the rollers. Thus, the transportation safety member is prevented from being moved by the user more than desired and also, the drum is prevented from moving upwards more than desired.
- [0012] In a derivative of this embodiment, an opening, which allows access to the transportation safety member through the base of the body, is arranged in the laundry dryer.
- [0013] In another embodiment of the present invention, the guide is positioned near one of the front corners of the body base. In this embodiment, the guide is not placed right below the drum but near the front corner of the body base eccentrically with respect to the vertical axis passing through the center of the drum. Thus, the magnitude of the force component applied by the transportation safety member towards the center of the drum is reduced and the drum is prevented from being damaged.
- [0014] In another embodiment of the present invention, the laundry dryer comprises two guides arranged at the front corners of the body base and

two transportation safety members inserted into those guides. Thus, the force acting on by means of the transportation safety member is dispersed and the convex shape of the drum is preserved.

- [0015] The model embodiments relating to a laundry dryer realized in order to attain the aim of the present invention are illustrated in the attached figures, where:
- [0016] Figure 1 – is the schematic view of a laundry dryer.
- [0017] Figure 2 – is the view of detail A in Figure 1 when the transportation safety member is in the first position.
- [0018] Figure 3 – is the view of detail A in Figure 1 when the transportation safety member is in the second position.
- [0019] Figure 4 – is the schematic view of a drum and a transportation safety member when the transportation safety member is in the first position in an embodiment of the present invention.
- [0020] Figure 5 – is the schematic view of a guide in an embodiment of the present invention.
- [0021] The elements illustrated in the figures are numbered as follows:
1. Laundry dryer
  2. Body
  3. Drum
  4. Roller
  5. Frame
  6. Transportation safety member
  7. Shaft
  8. Resting member
  9. Head
  10. Guide
  11. Stopper
  12. Opening
- [0022] The laundry dryer (1) comprises
- a body (2),
  - a drum (3) which rotates around the horizontal axis and wherein items to be dried are placed,

- more than one roller (4) whereon the drum (3) is seated and which supports the drum (3) by rotating around their own axes by the movement of the drum (3) during the drying process, and
- a frame (5) whereon the rollers (4) are rotatably mounted.

[0023] The laundry dryer (1) of the present invention comprises a transportation safety member (6) which has a first position wherein it does not contact the drum (3) and a second position wherein it contacts the drum (3) by being moved and provides the contact of the drum (3) with the rollers (4) to be broken (Figure 1).

[0024] When the laundry dryer (1) is to be transported, in order to provide the safety of the laundry dryer (1), the position of the transportation safety member (6) is changed so as to provide a certain distance (D) between the drum (3) and the rollers (4). The user first positions the laundry dryer (1) so as to allow access to the transportation safety member (6) and then provides the movement of the transportation safety member (6) inside the laundry dryer (1) by moving the transportation safety member (6). After the transportation safety member (6) contacts the drum (3) and separates the drum (3) from the rollers (4) as much as a certain distance (D), the laundry dryer (1) becomes ready for the transportation process (Figure 3).

[0025] When the laundry dryer (1) reaches the place to be transported, the transportation safety member (6) is changed from the second position to the first position. In this position, the drum (3) contacts the rollers (4). The laundry dryer (1) is positioned such that the transportation safety member (6) can be reached and then, by moving the transportation safety member (6), the drum (3) is provided to be seated onto the rollers (4) by means of the transportation safety member (6) (Figure 2).

[0026] In an embodiment of the present invention, the laundry dryer (1) comprises the transportation safety member (6) which moves the drum (3) upwards while being brought from the first position to the second position. Thus, the drum (3) is lifted upwards during transportation and by breaking the contact of the drum (3) with the rollers (4) damages that may occur if the laundry dryer (1) falls down are prevented.

[0027] In an embodiment of the present invention, the transportation safety

member (6) comprises a screw-shaped shaft (7) extending from the body (2) towards the drum (3), a resting member (8) which is located at the shaft (7) end facing the drum (3) and contacts the drum (3) when the transportation safety member (6) is in the second position, and a head (9) which is located at the lower end of the shaft (7) and allows the shaft (7) to be rotated. Thus, the pressure acting on the drum (3) by the resting member (8) is reduced and the drum (3) is prevented from being deformed due to the force applied onto the drum (3), and the distance between the transportation safety member (6) and the drum (3) is adjusted by means of the head (9) (Figure 4).

- [0028] In a derivative of this embodiment, the transportation safety member (6) comprises a resting member (8) having the same shape as the portion it contacts the drum (3). Thus, the resting member (8) uniformly contacts the drum (3).
- [0029] In a derivative of this embodiment, the laundry dryer (1) comprises the transportation safety member (6) which has a resting member (8) produced from elastomeric material. By means of the elastomeric material, the drum (3) is not damaged at the moment the resting member (8) contacts the drum (3), for example, in case that the drum (3) moves and falls down onto the resting member (8) during transportation.
- [0030] In an embodiment of the present invention, the laundry dryer (1) comprises a guide (10) which is located between the body (2) and the drum (3) and has a screw hole providing the shaft (7) of the transportation safety member (6) to be borne. Thus, the screw-shaped shaft (7) can be moved inside the guide (10) in the desired distance (Figure 4, Figure 5).
- [0031] In a derivative of this embodiment, the laundry dryer (1) comprises a stopper (11) which is located on the guide (10) and prevents the shaft (7) from leaving the guide (10) after the shaft (7) moves towards the drum (3), and the transportation safety member (6) which has a head (9) having a diameter greater than that of the shaft (7) so as to allow the transportation safety member (6) to be stopped by bearing against the stopper (11). Thus, the movement of the transportation safety member (6) inside the guide (10) is limited after the drum (3) is separated from the rollers (4) and

the drum (3) is prevented from hitting the upper surface of the frame (5) (Figure 4).

- [0032] In a derivative of this embodiment, the laundry dryer (1) comprises an opening (12) which is arranged on the body (2) at the level of the guide (10) and allows the transportation safety member (6) to be placed into the guide (10). Thus, the position of the transportation safety member (6) can be changed by reaching into the guide (10) through the opening (12).
- [0033] In a derivative of this embodiment, the laundry dryer (1) comprises the guide (10) which is positioned near one of the front corners of the body base (T). Thus, the transportation safety member (6) can be reached easily by bringing the laundry dryer (1) to a half-angled position.
- [0034] In a derivative of this embodiment, the laundry dryer (1) comprises two guides (10) located near the front corners of the body base (T) and two transportation safety members (6) mounted to the guides (10). Thus, it is possible to lift the drum (3) in a balanced manner and separate it from the rollers (4).
- [0035] The laundry dryer (1) of the present invention comprises a transportation safety member (6) that can have two positions. By changing the transportation safety member (6) to the second position, the drum (3) is separated from the rollers (4) it is seated on. Thus, the safety of the laundry dryer (1) during transportation is provided.
- [0036] It is to be understood that the present invention is not limited to the embodiments disclosed above and a person skilled in the art can easily introduce different embodiments. These should be considered within the scope of the protection postulated by the claims of the present invention.

## Claims

1. A laundry dryer (1) comprising
  - a body (2),
  - a drum (3) which rotates around the horizontal axis and wherein items to be dried are placed,
  - more than one roller (4) whereon the drum (3) is seated and which supports the drum (3) by rotating around their own axes by the movement of the drum (3) during the drying process, and
  - a frame (5) whereon the rollers (4) are rotatably mounted,**characterized by**
  - a transportation safety member (6) which has a first position wherein it does not contact the drum (3) and a second position wherein it contacts the drum (3) by being moved and provides the contact of the drum (3) with the rollers (4) to be broken
2. A laundry dryer (1) as in Claim 1, **characterized by** the transportation safety member (6) which moves the drum (3) upwards while being brought from the first position to the second position.
3. A laundry dryer (1) as in any one of the above claims, **characterized by** the transportation safety member (6) that comprises a shaft (7) which extends from the body (2) towards the drum (3), a resting member (8) which is located at the shaft (7) end facing the drum (3) and contacts the drum (3) when the transportation safety member (6) is in the second position, and a head (9) which is located at the lower end of the shaft (7) and allows the shaft (7) to be rotated.
4. A laundry dryer (1) as in Claim 3, **characterized by** the transportation safety member (6) which comprises a resting member (8) having the same shape as the portion it contacts the drum (3).
5. A laundry dryer (1) as in Claim 3 or 4, **characterized by** the transportation safety member (6) which comprises a resting member (8) produced from elastomeric material.
6. A laundry dryer (1) as in any one of the above claims, **characterized by** a guide (10) which is located between the body (2) and the drum (3) and has a screw hole providing the transportation safety member (6) to be borne.

7. A laundry dryer (1) as in Claim 6, **characterized by** a stopper (11) which is located on the guide (10) and prevents the shaft (7) from leaving the guide (10) after the shaft (7) moves towards the drum (3), and the transportation safety member (6) which has the head (9) having a diameter greater than that of the shaft (7) so as to allow the transportation safety member (6) to be stopped by bearing against the stopper (11).
8. A laundry dryer (1) as in Claim 6 or 7, **characterized by** an opening (12) which is arranged on the body (2) at the level of the guide (10) and allows the transportation safety member (6) to be placed into the guide (10).
9. A laundry dryer (1) as in any one of the Claims 6 to 8, **characterized by** the guide (10) which is positioned near one of the front corners of the body base (T).
10. A laundry dryer (1) as in any one of the Claims 6 to 9, **characterized by** two guides (10) which are located near the front corners of the body base (T).

Figure 1

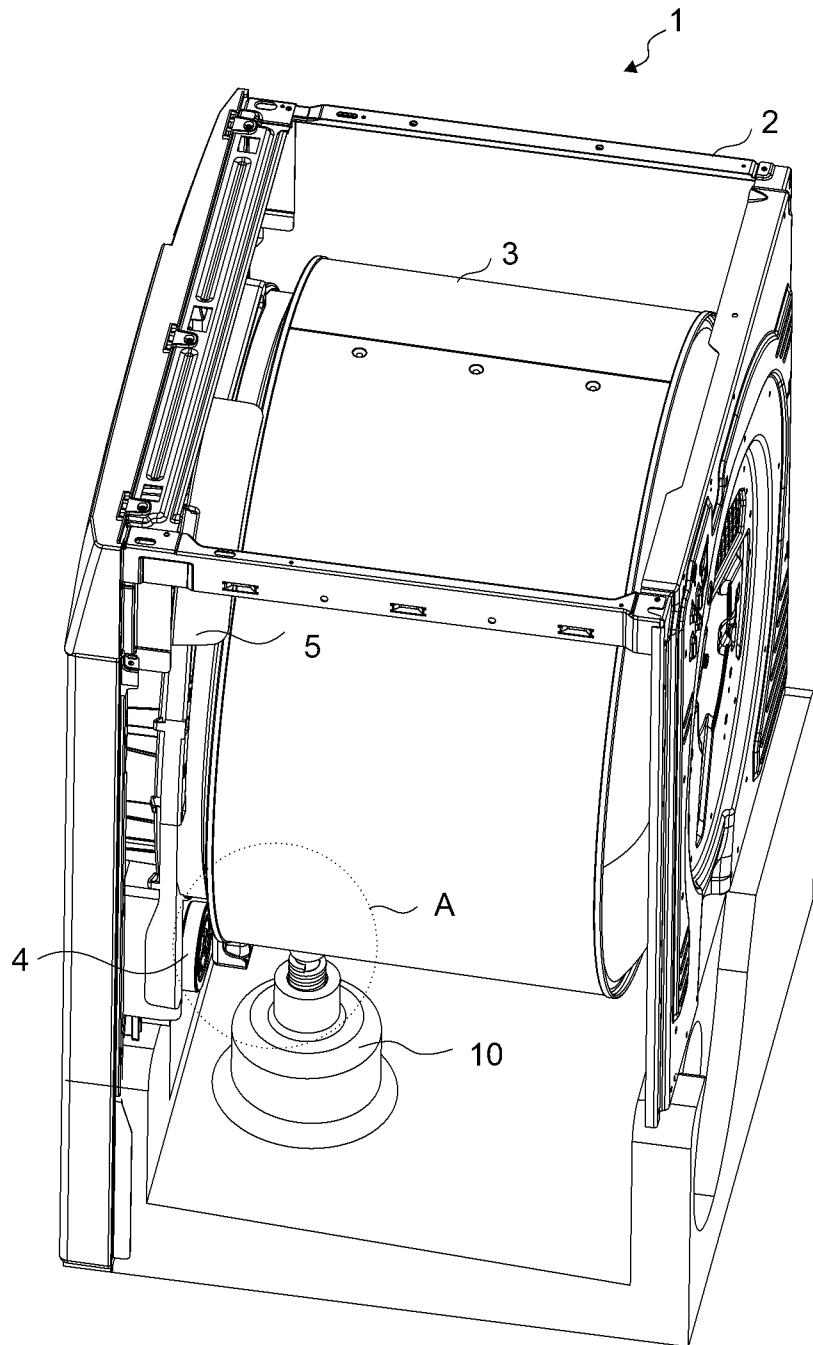

Figure 2

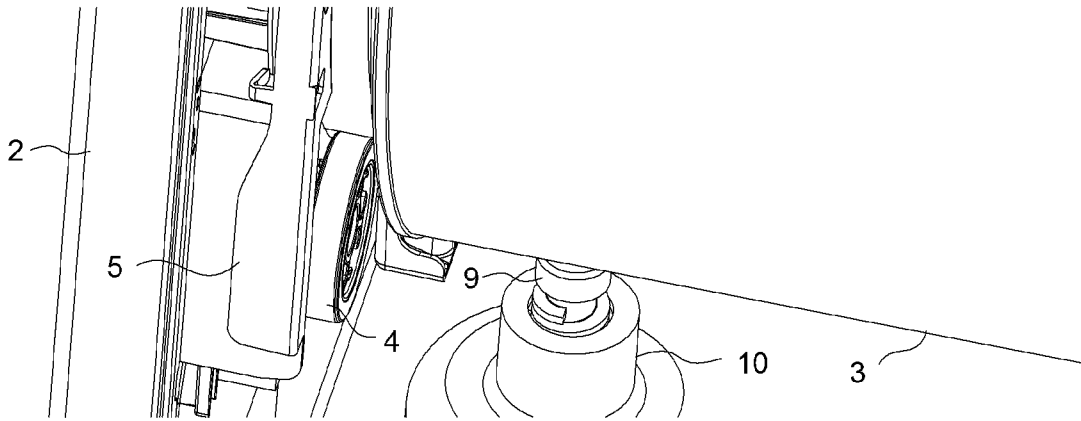

Figure 3

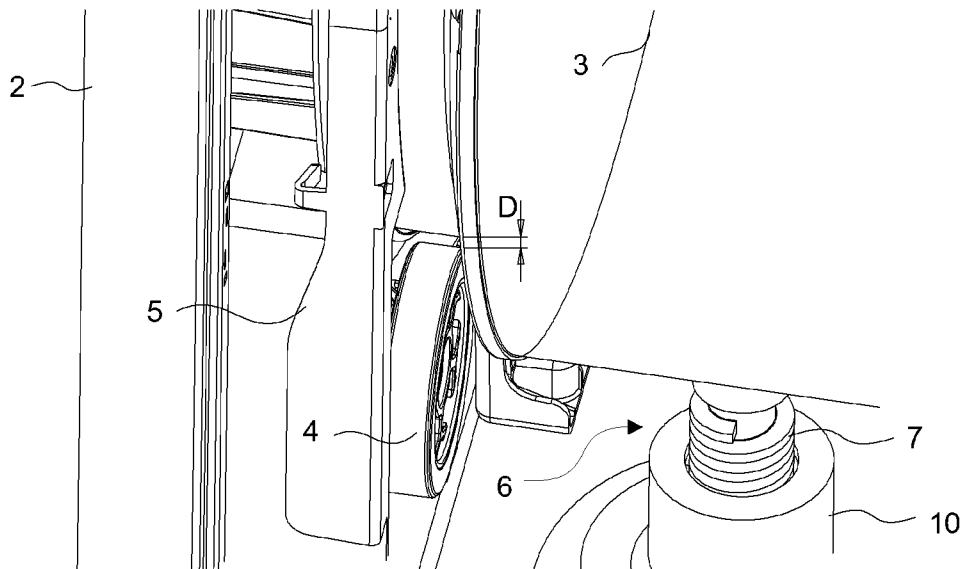

Figure 4

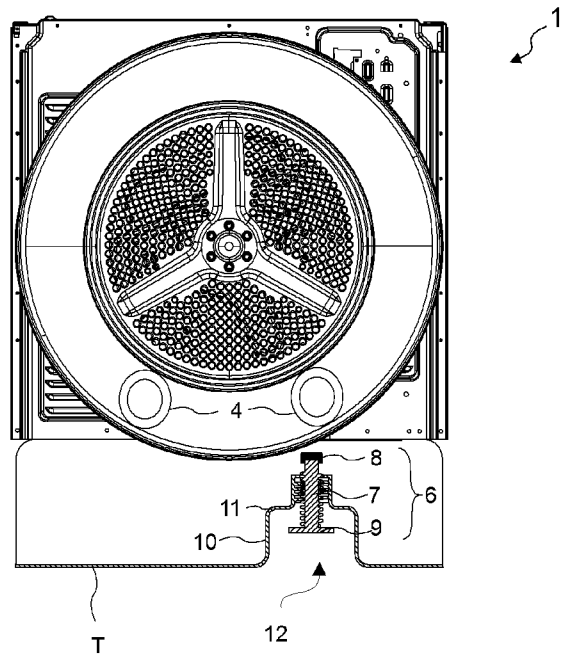
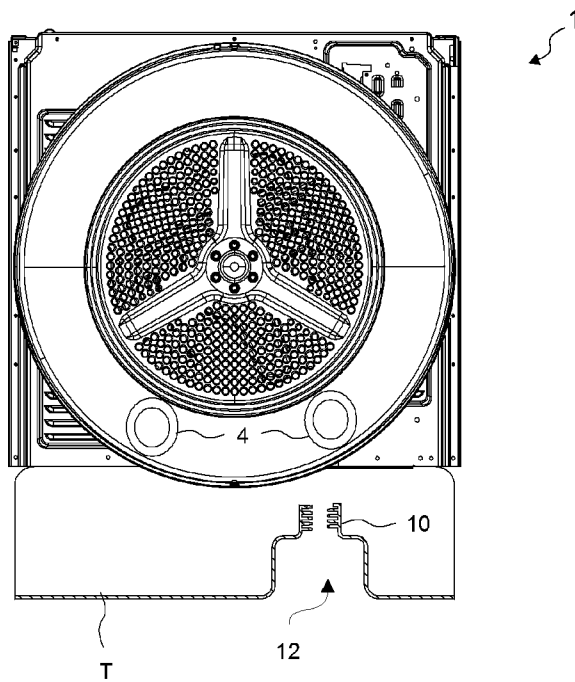

Figure 5



INTERNATIONAL SEARCH REPORT

International application No  
PCT/EP2012/071617

A. CLASSIFICATION OF SUBJECT MATTER  
INV. D06F58/04 D06F58/06  
ADD.  
According to International Patent Classification (IPC) or to both national classification and IPC

B. FIELDS SEARCHED  
Minimum documentation searched (classification system followed by classification symbols)  
D06F  
Documentation searched other than minimum documentation to the extent that such documents are included in the fields searched

Electronic data base consulted during the international search (name of data base and, where practicable, search terms used)  
EPO-Internal, WPI Data

C. DOCUMENTS CONSIDERED TO BE RELEVANT		
Category*	Citation of document, with indication, where appropriate, of the relevant passages	Relevant to claim No.
A	DE 10 2005 009230 A1 (JENSEN SENKING GMBH [DE]) 7 September 2006 (2006-09-07) the whole document -----	1-10
A	EP 0 136 491 A2 (ZANUSSI A SPA INDUSTRIE [IT]) 10 April 1985 (1985-04-10) the whole document -----	1-10
A	EP 0 404 252 A1 (OCEAN SPA [IT]) 27 December 1990 (1990-12-27) the whole document -----	1-10
A	WO 2005/066409 A1 (ARCELIK AS [TR]; YILDIRIM IBRAHIM [TR]) 21 July 2005 (2005-07-21) cited in the application the whole document -----	1-10

Further documents are listed in the continuation of Box C.

See patent family annex.

\* Special categories of cited documents :

"A" document defining the general state of the art which is not considered to be of particular relevance	"T" later document published after the international filing date or priority date and not in conflict with the application but cited to understand the principle or theory underlying the invention
"E" earlier application or patent but published on or after the international filing date	"X" document of particular relevance; the claimed invention cannot be considered novel or cannot be considered to involve an inventive step when the document is taken alone
"L" document which may throw doubts on priority claim(s) or which is cited to establish the publication date of another citation or other special reason (as specified)	"Y" document of particular relevance; the claimed invention cannot be considered to involve an inventive step when the document is combined with one or more other such documents, such combination being obvious to a person skilled in the art
"O" document referring to an oral disclosure, use, exhibition or other means	"&" document member of the same patent family
"P" document published prior to the international filing date but later than the priority date claimed	

Date of the actual completion of the international search  20 December 2012	Date of mailing of the international search report  07/01/2013
---	--

Name and mailing address of the ISA/ European Patent Office, P.B. 5818 Patentlaan 2 NL - 2280 HV Rijswijk Tel. (+31-70) 340-2040, Fax: (+31-70) 340-3016	Authorized officer  Jeziarski, Krzysztof
--	--

# INTERNATIONAL SEARCH REPORT

Information on patent family members

International application No PCT/EP2012/071617
---

Patent document cited in search report	Publication date	Patent family member(s)	Publication date
DE 102005009230 A1	07-09-2006	NONE	
-----			
EP 0136491	A2	10-04-1985	
		DE 3479043 D1	24-08-1989
		EP 0136491 A2	10-04-1985
-----			
EP 0404252	A1	27-12-1990	
		EP 0404252 A1	27-12-1990
		IT 216704 Z2	19-09-1991
-----			
WO 2005066409	A1	21-07-2005	
		AT 491062 T	15-12-2010
		EP 1702097 A1	20-09-2006
		TR 200603230 T1	22-01-2007
		WO 2005066409 A1	21-07-2005
-----			