



US 20050230456A1

(19) **United States**

(12) **Patent Application Publication**

Yao et al.

(10) **Pub. No.: US 2005/0230456 A1**

(43) **Pub. Date: Oct. 20, 2005**

(54) **SYSTEM AND METHOD FOR
MANUFACTURE OF A HARD DISK DRIVE
ARM AND BONDING OF MAGNETIC HEAD
TO SUSPENSION ON A DRIVE ARM**

(76) Inventors: **Ming Gao Yao**, Dongguan City (CN);
Masashi Shiraishi, Hung Hom (HK);
Yi Ru Xie, Dongguan City (CN)

Correspondence Address:
KENYON & KENYON
Suite 600
333 W. San Carlos
San Jose, CA 95110-2711 (US)

(21) Appl. No.: **11/159,634**

(22) Filed: **Jun. 22, 2005**

Related U.S. Application Data

(62) Division of application No. 10/603,444, filed on Jun. 24, 2003.

(30) **Foreign Application Priority Data**

Jan. 20, 2003 (WO)..... PCT/CN03/00048

Publication Classification

(51) **Int. Cl.⁷** **G11B 5/012**

(52) **U.S. Cl.** **228/110.1**

(57) **ABSTRACT**

A system and method are disclosed for the manufacture of a hard disk drive arm and the bonding of magnetic head to suspension on the drive arm.

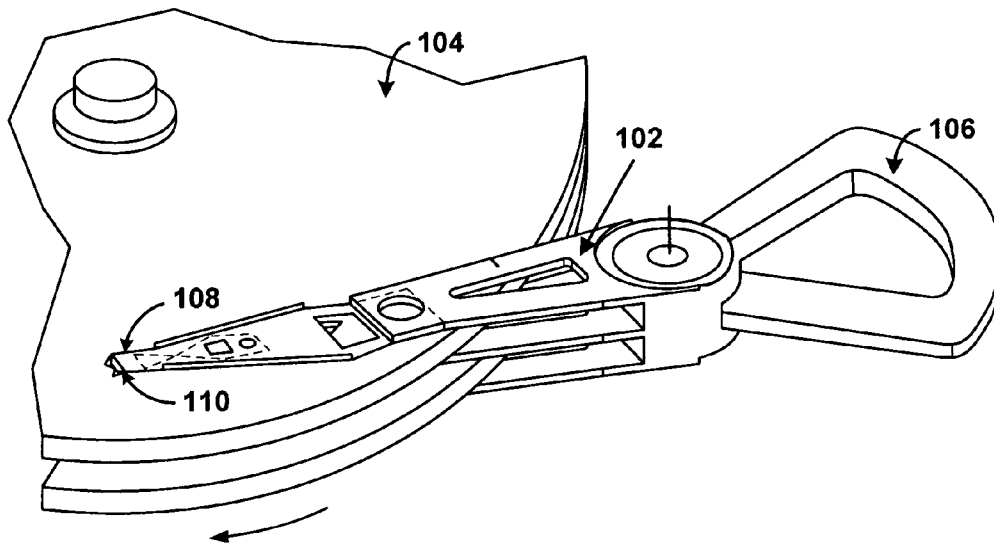

Figure 1
(Prior Art)

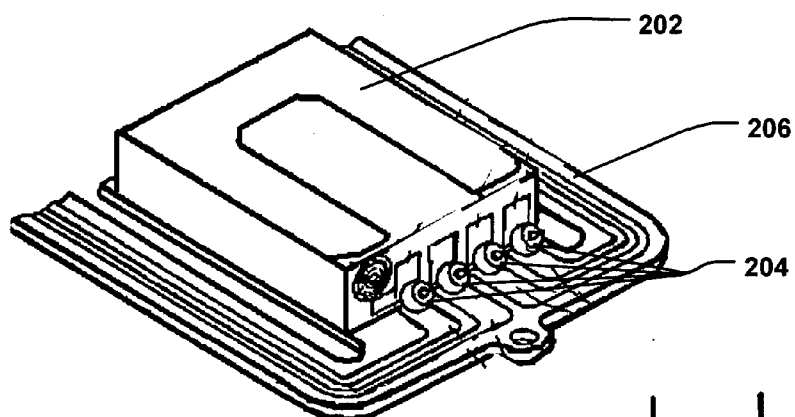
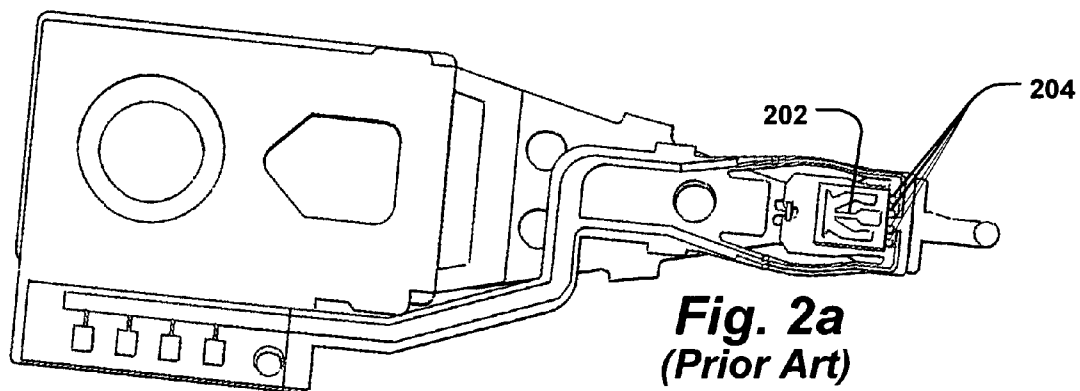

Fig. 2b
(Prior Art)

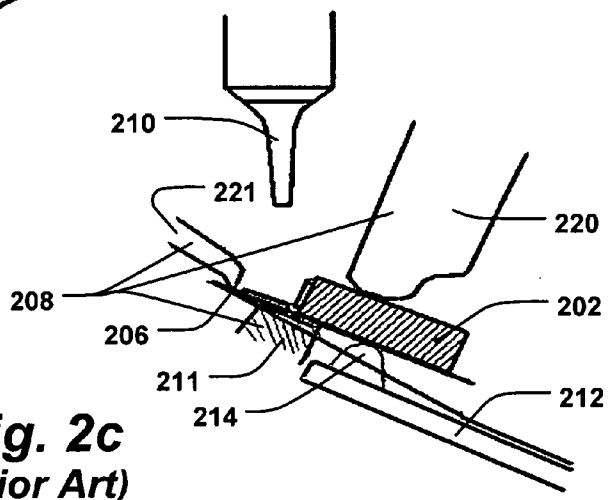

Fig. 2c
(Prior Art)

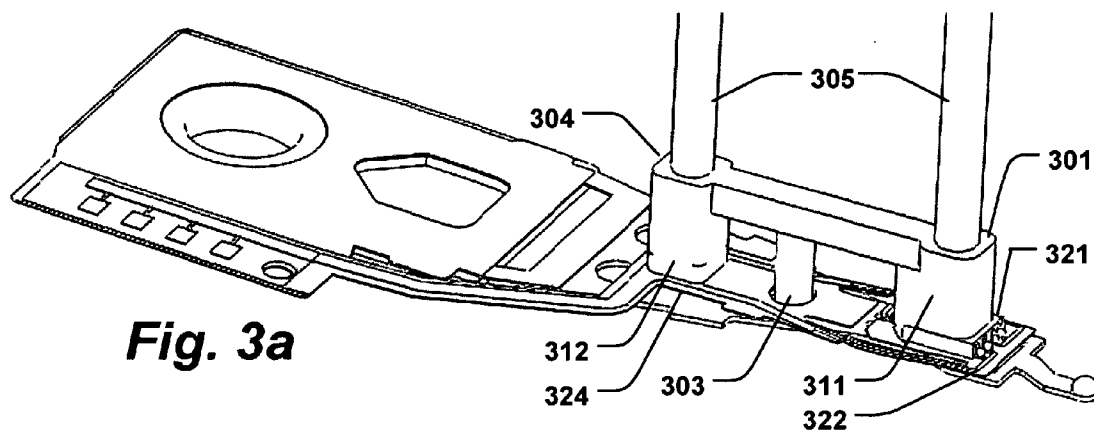

Fig. 3a

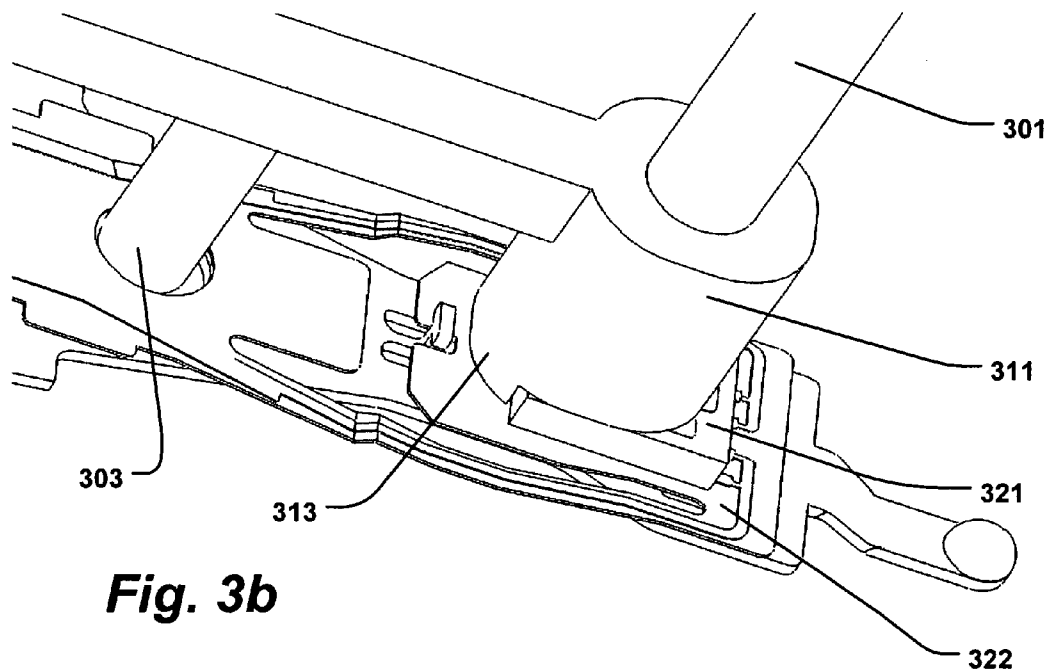

Fig. 3b

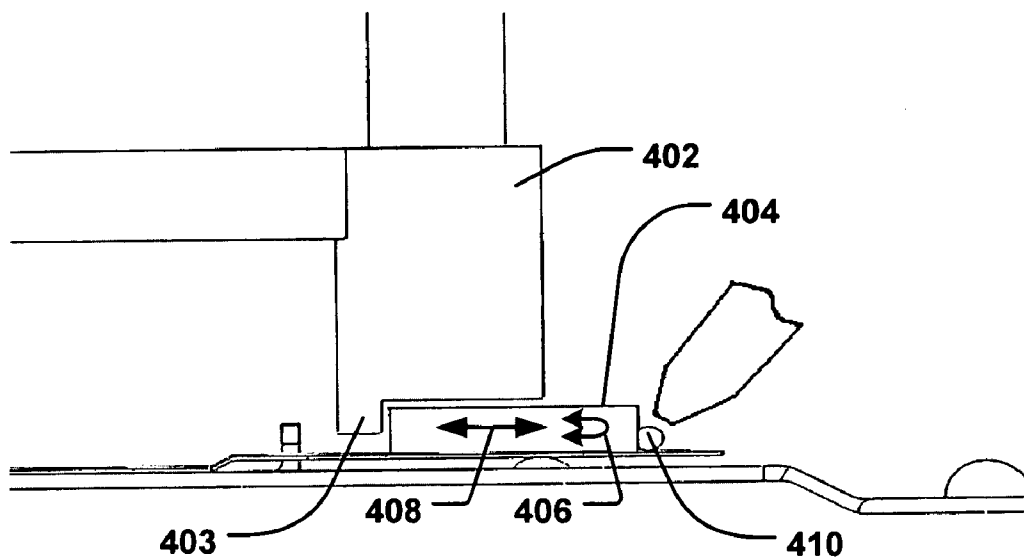

Fig. 4a

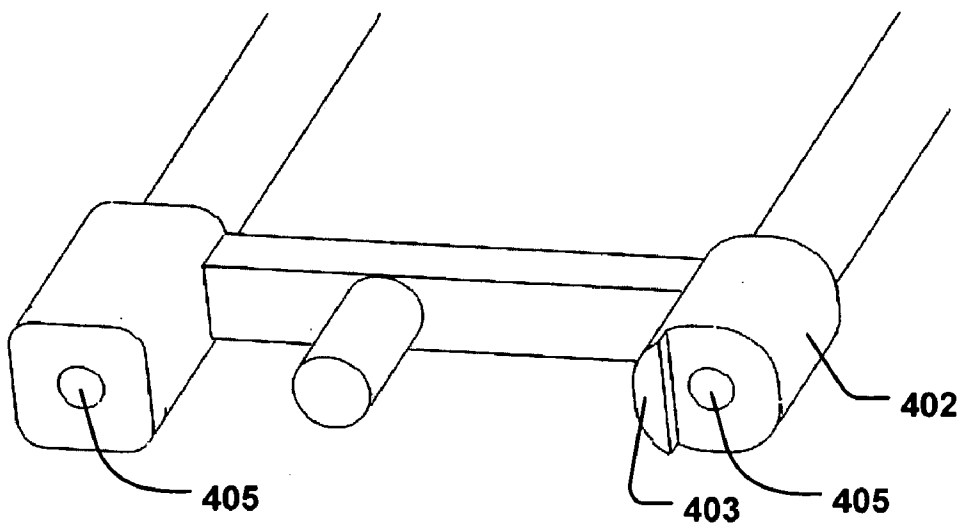

Fig. 4b

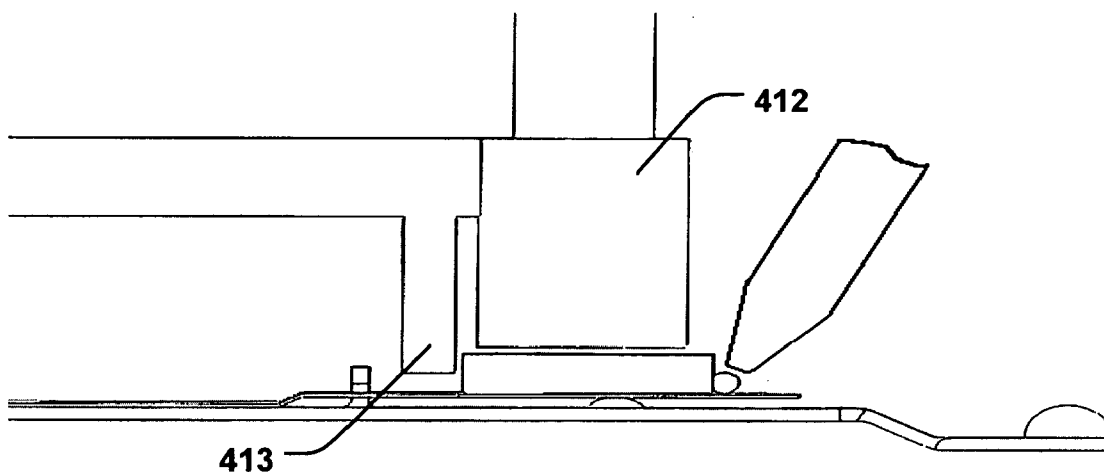

Fig. 4c

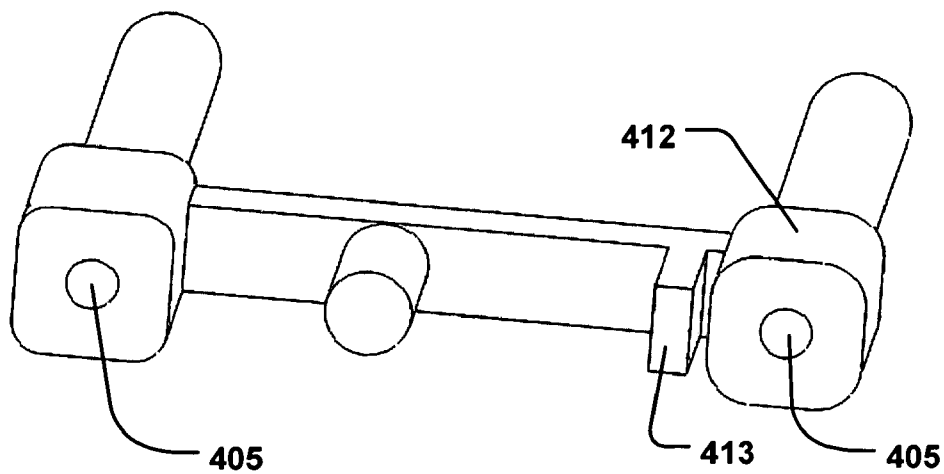

Fig. 4d

Fig. 5a

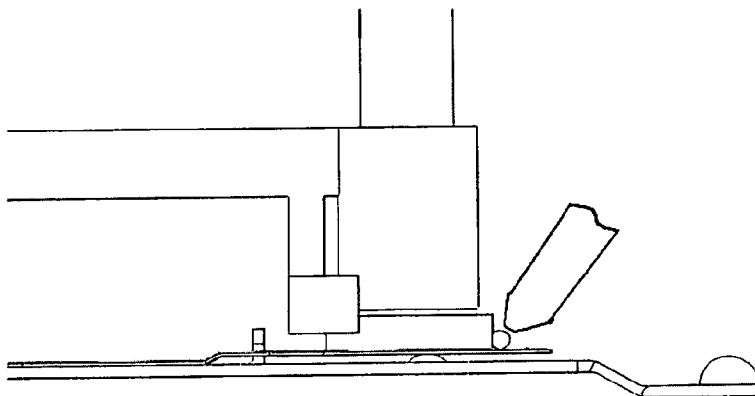

Fig. 5b

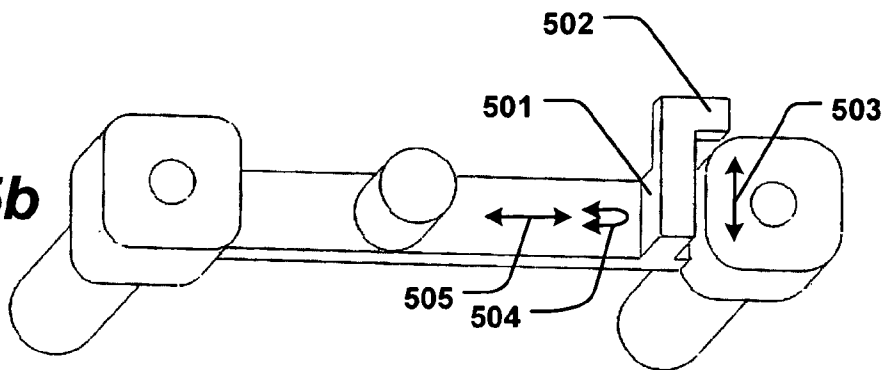

Fig. 5c

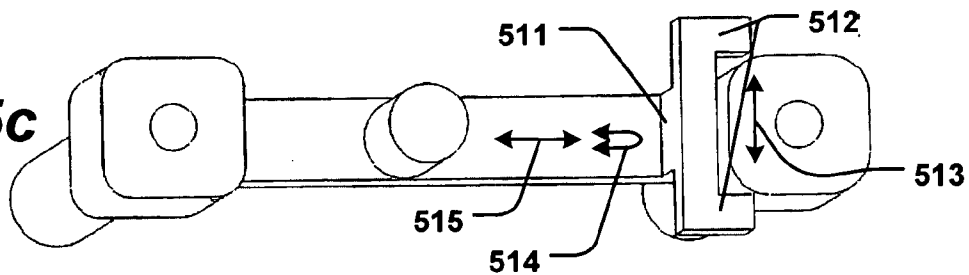
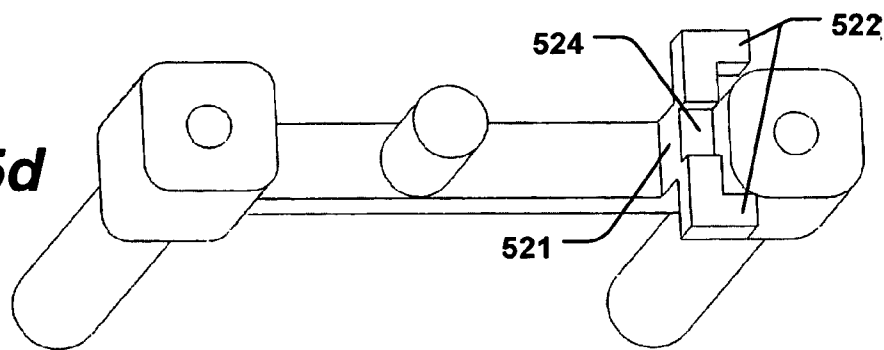
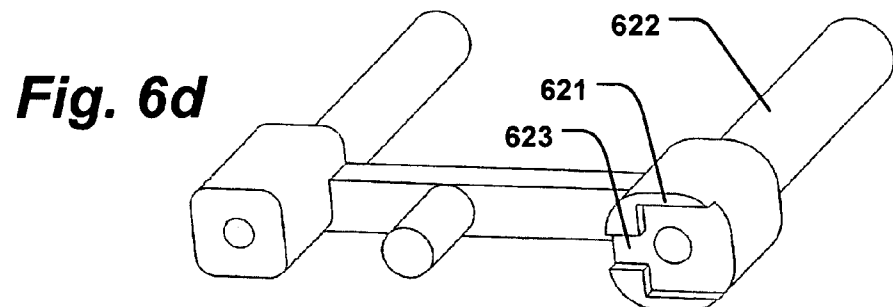
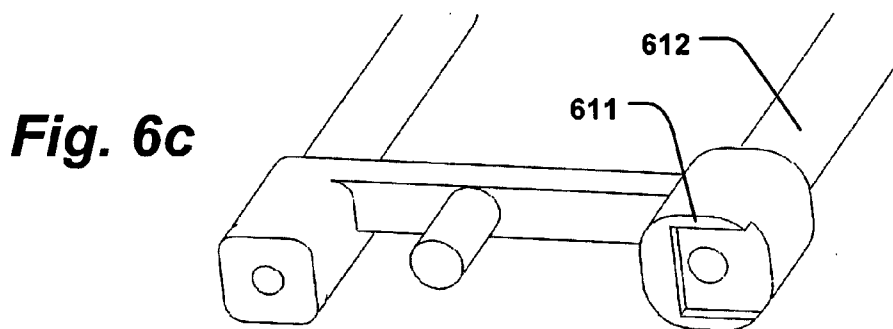
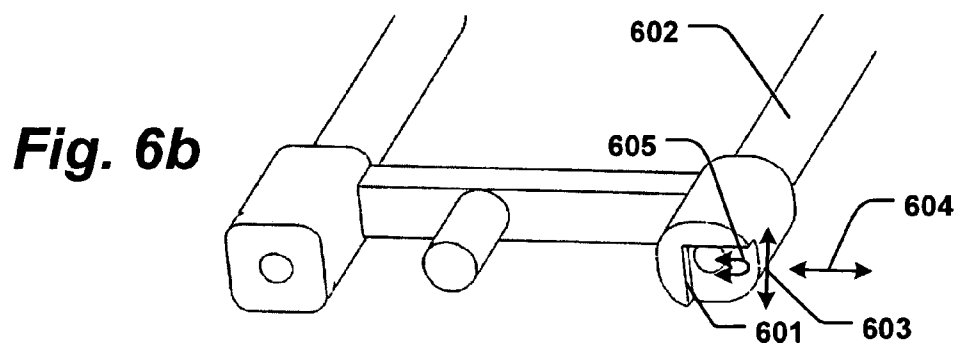
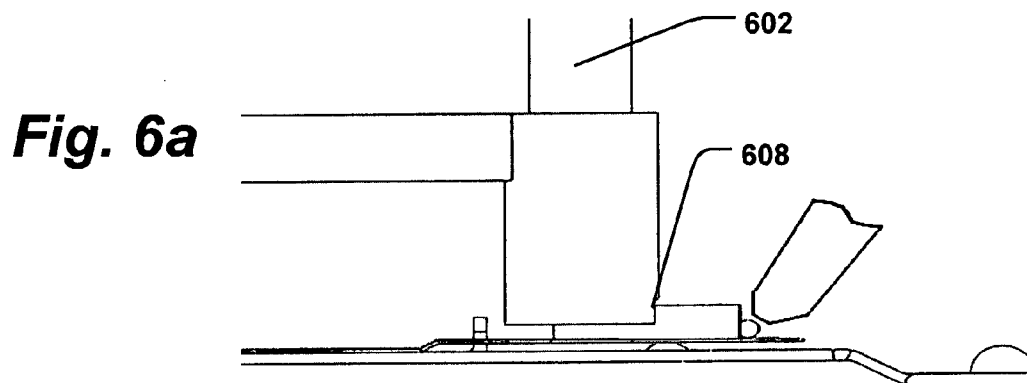

Fig. 5d





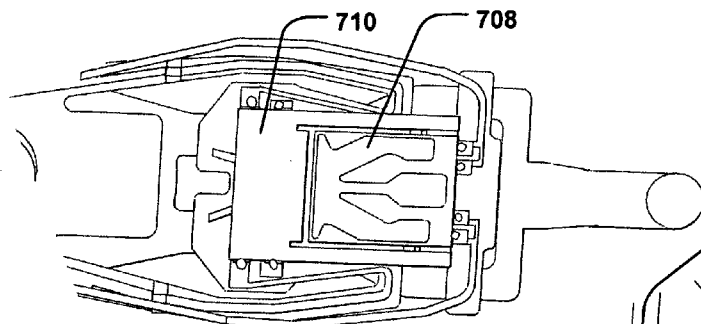

Fig. 7a

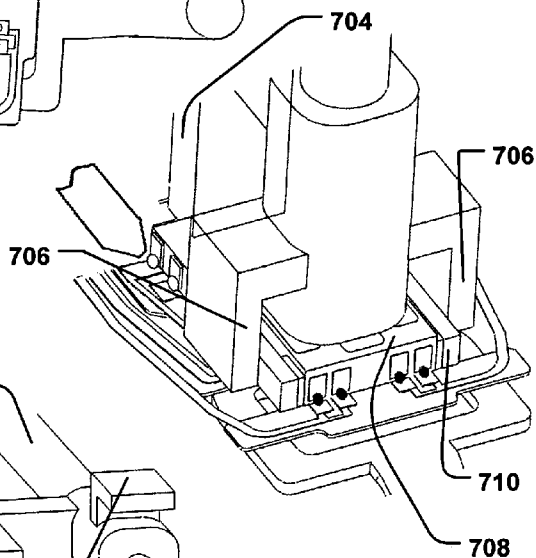

Fig. 7b

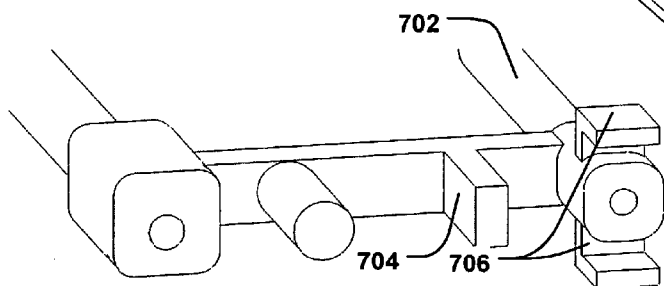

Fig. 7c

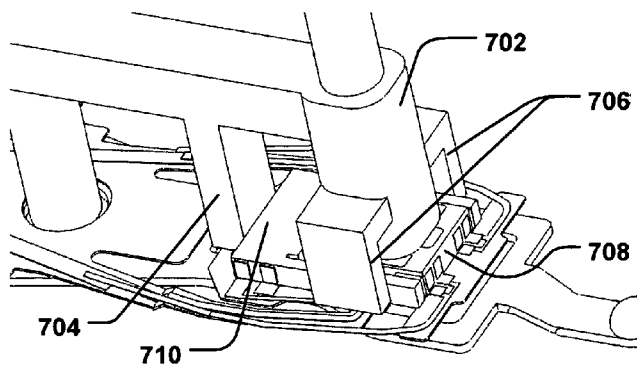

Fig. 7d

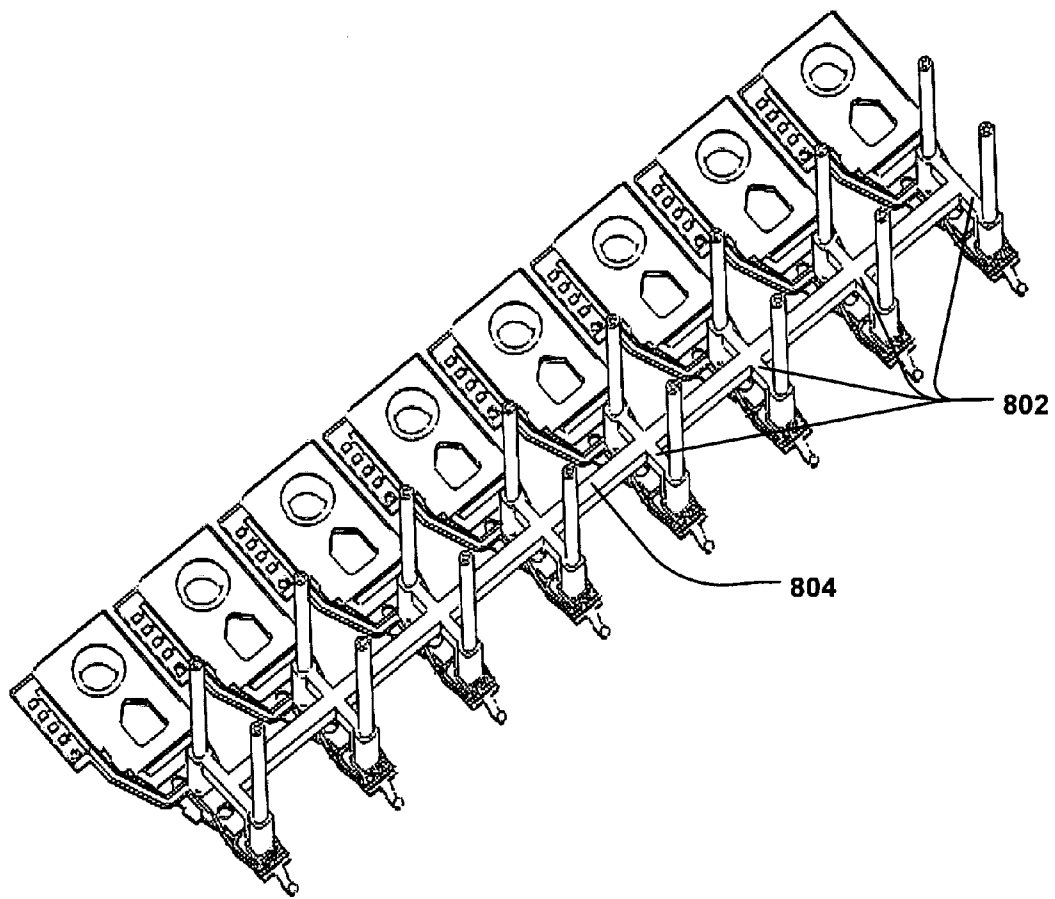

Figure 8

SYSTEM AND METHOD FOR MANUFACTURE OF A HARD DISK DRIVE ARM AND BONDING OF MAGNETIC HEAD TO SUSPENSION ON A DRIVE ARM

BACKGROUND INFORMATION

[0001] The present invention relates to magnetic hard disk drives. More specifically, the invention relates to a system for manufacturing a hard disk drive arm and the bonding of magnetic head to suspension on the drive arm.

[0002] Among the better known data storage devices are magnetic disk drives of the type in which a magnetic head slider assembly floats on an air bearing at the surface of a rotating magnetic disk. Such disk drives are often called 'Winchester'-type drives. In these, one or more rigid magnetic disks are located within a sealed chamber together with one or more magnetic head slider assemblies. The magnetic disk drive may include one or more rigid magnetic disks, and the slider assemblies may be positioned at one or both sides of the magnetic disks.

[0003] FIG. 1 provides an illustration of a typical hard drive as used in the art. The slider assembly 108 may be mounted in a manner which permits gimballed movement at the free outer end of the arm 102 such that an air bearing between the slider assembly 108 and the surface of the magnetic disk 104 can be established and maintained. The drive arm 102 is coupled to an appropriate mechanism, such as a voice-coil motor (VCM) 106, for moving the arm 102 across the surface of the disk 104 so that a magnetic head contained within the slider assembly 108 can address specific concentric data tracks on the disk 104 for writing information onto or reading information from the data tracks.

[0004] FIG. 2 provides an illustration of a hard drive arm and magnetic head as used in the art. Typically, the magnetic head (slider) 202 is electrically connected to the head gimbal assembly (HGA) by bonding means, such as gold ball bonding (GBB), solder bump bonding (SBB), and ultrasonic welding. Typically, four connection points (balls) 204 are provided to electrically connect the magnetic head 202 to the suspension tongue/head gimbal assembly (HGA) 206. Two of the balls 204 are for the 'read' operation, and two of the balls 204 are for the 'write' operation. To prevent the bonding balls 204 from hardening with the magnetic head 202 in an undesirable orientation, a fixture 208 is used to strongly clamp the suspension tongue 206 and head 202 to be physically stable for ball 204 application by a soldering tool 210, etc. A base support 211 and a first clamping cover 220 stabilize the magnetic head 202. A second clamping cover 221 stabilizes the suspension tongue 206. A second base support (not shown) secures the load beam 212. This fixture 208 is utilized to prevent a change in orientation of the head 202 by the force of the soldering tool 210 during application. However, the clamping force of the fixture 208 is often enough to deform the magnetic head 202 and suspension tongue 212 structure causing improper orientation (alignment). Further, the forces involved have a tendency to damage the head 202 surface as well as the head suspension dimple 214.

[0005] It is therefore desirable to have a system to enable magnetic head electrical bonding while avoiding the aforementioned problems, in addition to providing other advantages.

BRIEF DESCRIPTION OF THE DRAWINGS

[0006] FIG. 1 provides an illustration of a typical hard drive as used in the art.

[0007] FIG. 2 provides an illustration of a hard drive arm and magnetic head as used in the art.

[0008] FIG. 3 illustrates a hard drive arm suspension, magnetic head, and head placement device according to an embodiment of the present invention.

[0009] FIG. 4 illustrates placement device design according to two different embodiments of the present invention.

[0010] FIG. 5 illustrates placement device design according to three additional embodiments of the present invention.

[0011] FIG. 6 illustrates placement device design according to three further embodiments of the present invention.

[0012] FIG. 7 illustrates placement device design for 'U'-shaped micro-actuator accommodation according to an embodiment of the present invention.

[0013] FIG. 8 illustrates the design of a simultaneous operation placement device according to an embodiment of the present invention.

DETAILED DESCRIPTION

[0014] FIG. 3 illustrates a hard drive arm suspension, magnetic head, and head placement device according to an embodiment of the present invention. As shown in FIG. 3a, in one embodiment, the placement device 305 has two vacuum tubes 301, 304. The first vacuum pipe (tube) 301 has a fixture 311 that mates to the magnetic head 321 of a hard drive. As shown in FIG. 3b, in this embodiment, the first vacuum tube fixture 311 has a stepped 313 surface that mates with the head 321 in such a way that prevents rotational motion of the head 321 with respect to the placement device 305 (and thus, the suspension tongue 322). In one embodiment, the step 313 is between 100 micrometers and 280 micrometers. In one embodiment, the second vacuum tube has a fixture mate-able to the load beam 324. Further, an alignment pin 303 is provided that is capable of being inserted into the tooling hole of the load beam 324 for ensuring proper alignment. In this embodiment, the placement device is secured to the magnetic head 321 and load beam 324 by sub-ambient pressure imposed by the first 301 and second 302 vacuum tubes, the first vacuum tube 301 applying suction force to the air bearing surface (ABS) of the slider/head 321 and the second vacuum tube 302 applying suction force to the load beam 324.

[0015] FIG. 4 illustrates placement device design according to two different embodiments of the present invention. In one embodiment, shown in FIGS. 4a and 4b, the fixture 402 of the first vacuum tube has an integrated step 403 to prevent rotational (yaw) 406 and longitudinal 408 motion of the magnetic head 404 during bonding ball 410 application. In another embodiment, shown in FIGS. 4c and 4d, the fixture 412 of the first vacuum tube has an externally-mounted step structure 413. Further, FIGS. 4b and 4d illustrate the air inlets of the first and second vacuum tubes.

[0016] FIG. 5 illustrates placement device design according to three additional embodiments of the present invention. As shown in FIG. 5b, in one embodiment, an exter-

nally-mounted step structure **501** is provided with a side protrusion **502** to prevent transverse **503** motion (as well as longitudinal **504** and rotational **505** motion) of the magnetic head **508** (See **FIG. 5a**). As shown in **FIG. 5c**, in another embodiment, an externally-mounted step structure **511** is provided with two side protrusions **512** to prevent transverse **513** motion (as well as longitudinal **514** and rotational **515** motion) of the magnetic head **508** (See **FIG. 5a**). As shown in **FIG. 5d**, in yet another embodiment, an externally-mounted step structure **521** is provided with two side protrusions **522**. Further, in this embodiment, a notch **524** is provided in the step **521** to allow for arm component clearance.

[0017] **FIG. 6** illustrates placement device design according to three further embodiments of the present invention. As shown in **FIG. 6b**, in one embodiment, the first vacuum tube **602** has an 'L'-shaped step structure **601** integrated in its mating surface to prevent transverse **603** motion (as well as longitudinal **604** and rotational **605** motion) of the magnetic head **608** (See **FIG. 6a**). As shown in **FIG. 6c**, in another embodiment, the first vacuum tube **612** has a 'U'-shaped step structure **611** integrated in its mating surface. As shown in **FIG. 6d**, in yet another embodiment, the first vacuum tube **622** has a 'U'-shaped step structure **621** integrated in its mating surface with a notch **623** provided to allow for arm component clearance.

[0018] **FIG. 7** illustrates placement device design for 'U'-shaped micro-actuator accommodation according to an embodiment of the present invention. As shown in **FIGS. 7b, 7c, and 7d**, in one embodiment, a first vacuum tube **702** has an externally-mounted step **704** and two side-mounted steps **706** to restrict the motion of a magnetic head **708** that is mounted in a micro-actuator, such as a 'U'-shaped micro-actuator **710**. This embodiment accommodates the shape of such a micro-actuator **710** while preventing the motion of the head **708** and micro-actuator **710** during the bonding process.

[0019] **FIG. 8** illustrates the design of a simultaneous operation placement device according to an embodiment of the present invention. In one embodiment, multiple individual placement devices **802** are combined into one machine **804** in order to stabilize components of many hard drive load arms for simultaneous head bonding operations.

[0020] Although several embodiments are specifically illustrated and described herein, it will be appreciated that modifications and variations of the present invention are covered by the above teachings and within the purview of the appended claims without departing from the spirit and intended scope of the invention.

1. A system for manufacturing a data storage device comprising:

a placement device to physically stabilize a hard drive head device for electrical bonding of said head device to a hard drive arm component, wherein

said placement device utilizes sub-ambient pressure to maintain the position of said head device with respect to said arm component for said electrical bonding.

2. The system of claim 1, wherein said hard drive head device is a hard disk drive magnetic head.

3. The system of claim 2, wherein said hard drive arm component is a suspension tongue.

4. The system of claim 1, wherein said electrical bonding is ball bonding.

5. The system of claim 4, wherein said electrical bonding is a type selected from the group consisting of gold ball bonding (GBB), solder bump bonding (SBB), ultrasonic welding, and stitch bonding.

6. The system of claim 1, wherein said placement device includes a first vacuum tube structure for providing said sub-ambient pressure to affix said first vacuum tube structure to said head device.

7. The system of claim 6, further comprising an alignment pin protruding from said placement device.

8. The system of claim 7, wherein said alignment pin is capable of being inserted into a suspension tooling hole for ensuring said proper alignment.

9. The system of claim 7, further comprising a second vacuum tube structure for providing sub-ambient pressure, wherein said first vacuum tube structure vacuum-couples to said head device and said second vacuum tube structure vacuum-couples to a suspension load beam attached to said arm component.

10. The system of claim 9, wherein the first vacuum tube structure includes a step structure mate-able to an edge of the head device.

11. The system of claim 10, wherein said step structure is mate-able to one or more edges of said head device.

12. The system of claim 11, wherein said step structure is an integral structure of the first vacuum tube.

13. The system of claim 11, wherein said step structure is an external structure.

14. The system of claim 9, wherein said first vacuum tube structure is a material selected from the group consisting of Stainless Steel, Copper, Aluminum Oxide, Polyimide, and Ceramic.

15. The system of claim 9, wherein said second vacuum tube structure is a material selected from the group consisting of Stainless Steel, Copper, Aluminum Oxide, Polyimide, and Ceramic.

16-28. (canceled)

* * * * *