



(19) **United States**
(12) **Patent Application Publication**
Lederer

(10) **Pub. No.: US 2012/0036737 A1**
(43) **Pub. Date: Feb. 16, 2012**

(54) **TONGUE AND INTERLOCKING SYSTEM FOR SHOES**

Publication Classification

(76) Inventor: **Stefan Lederer, Munchen (DE)**

(51) **Int. Cl.**
A43B 23/26 (2006.01)
(52) **U.S. Cl.** **36/54**

(21) Appl. No.: **13/265,873**

(57) **ABSTRACT**

(22) PCT Filed: **May 4, 2010**

The present invention relates to a tongue for shoes comprising: a basic structure of an essentially non-elastic material, having a top side facing away from a foot, and a bottom side facing the foot; a retaining device on the top side of the basic structure, wherein the retaining device is structured such that it can fixedly accommodate at least one pulling element; and a padding on the bottom side of the basic structure, wherein the basic structure is designed such that across the entire surface, the tongue can lie form-fittingly on the foot, and that both on the right and the left side, the tongue is pre-molded according to the anatomy of the dorsum of the foot, and wherein in the tongue a plurality of perforation is provided. The present invention further relates to an interlocking system for shoes, which includes same tongue.

(86) PCT No.: **PCT/EP2010/056022**

§ 371 (c)(1),
(2), (4) Date: **Oct. 23, 2011**

(30) **Foreign Application Priority Data**

May 4, 2009 (EP) 10 2009 019893.8

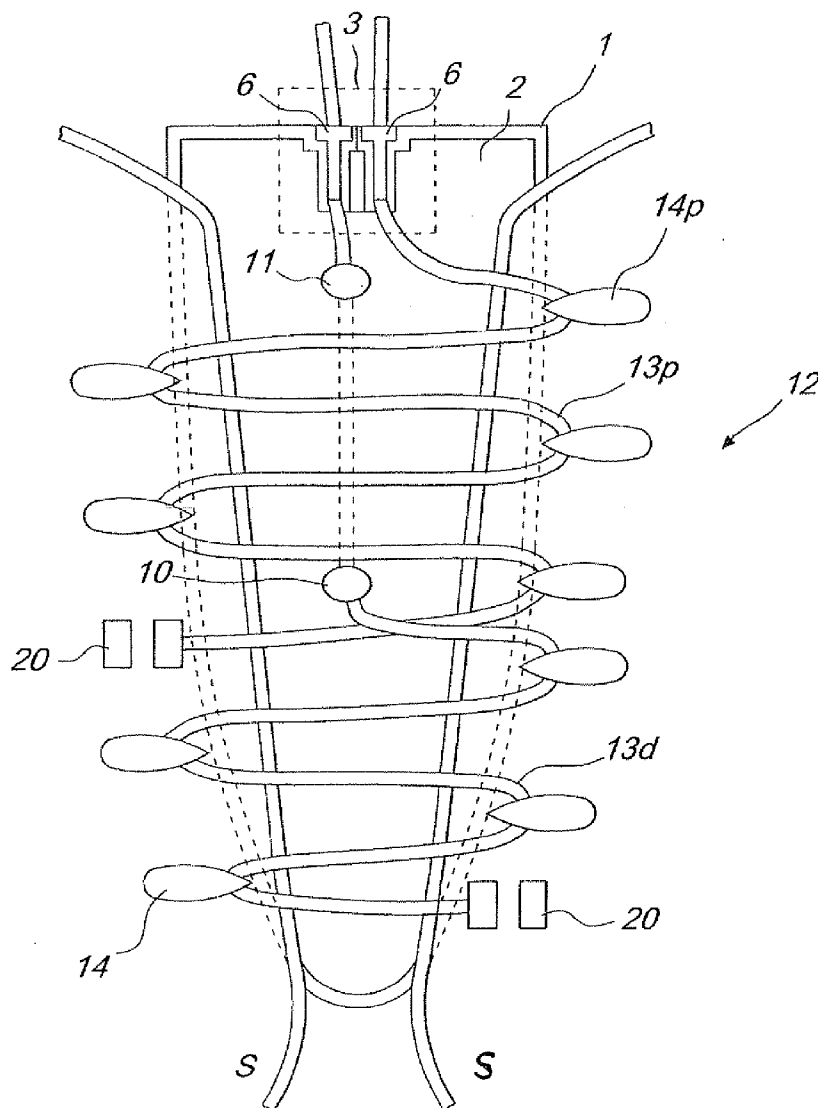

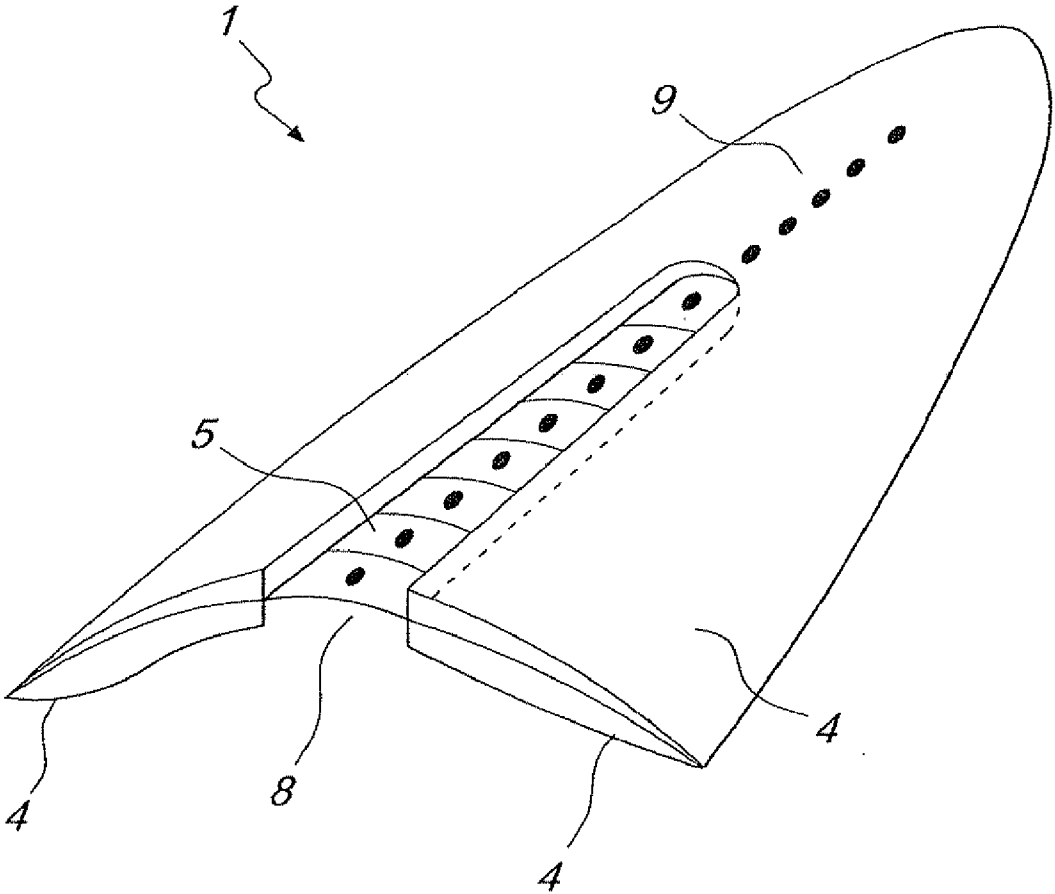

Fig. 1

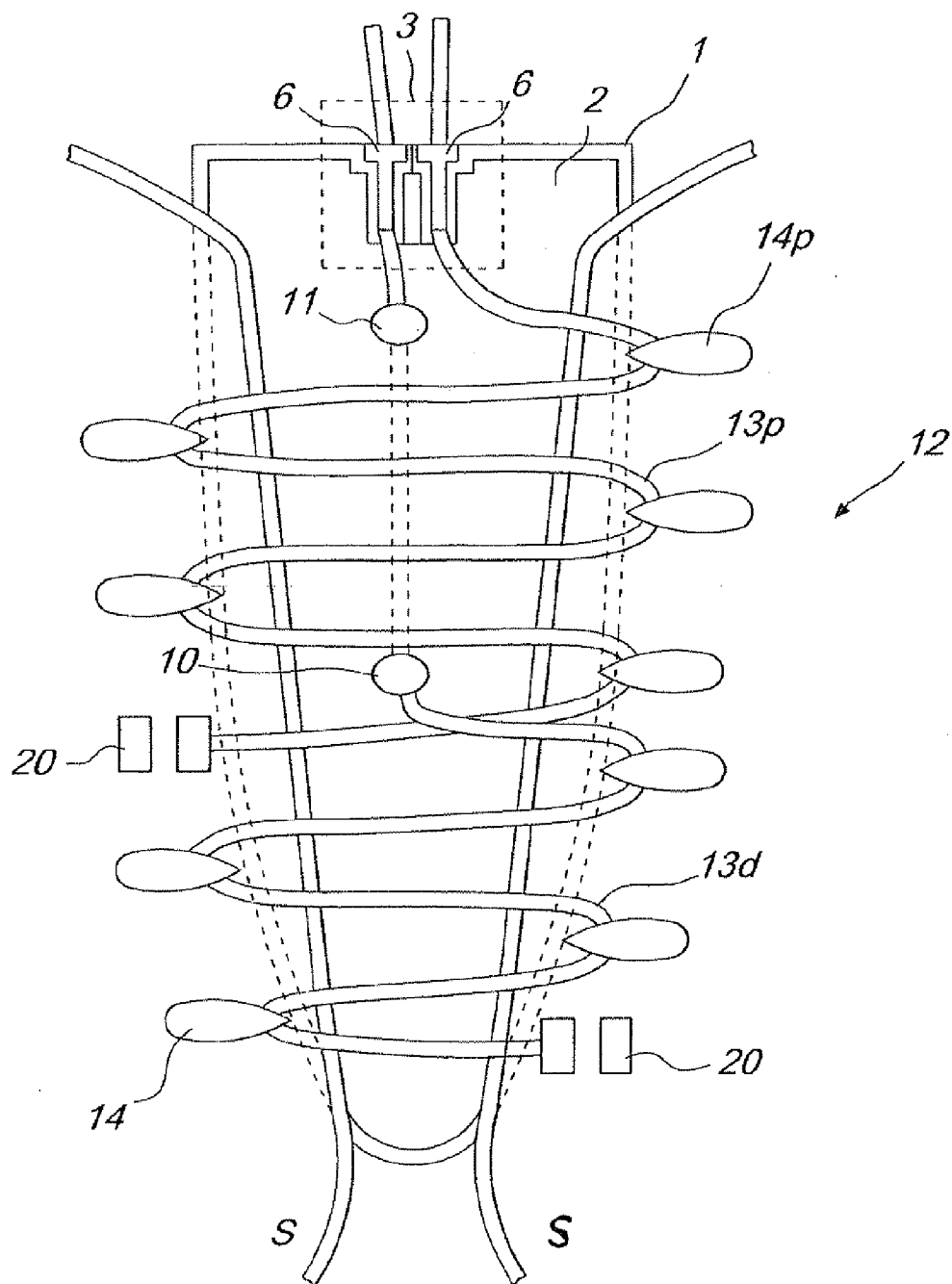

Fig. 2

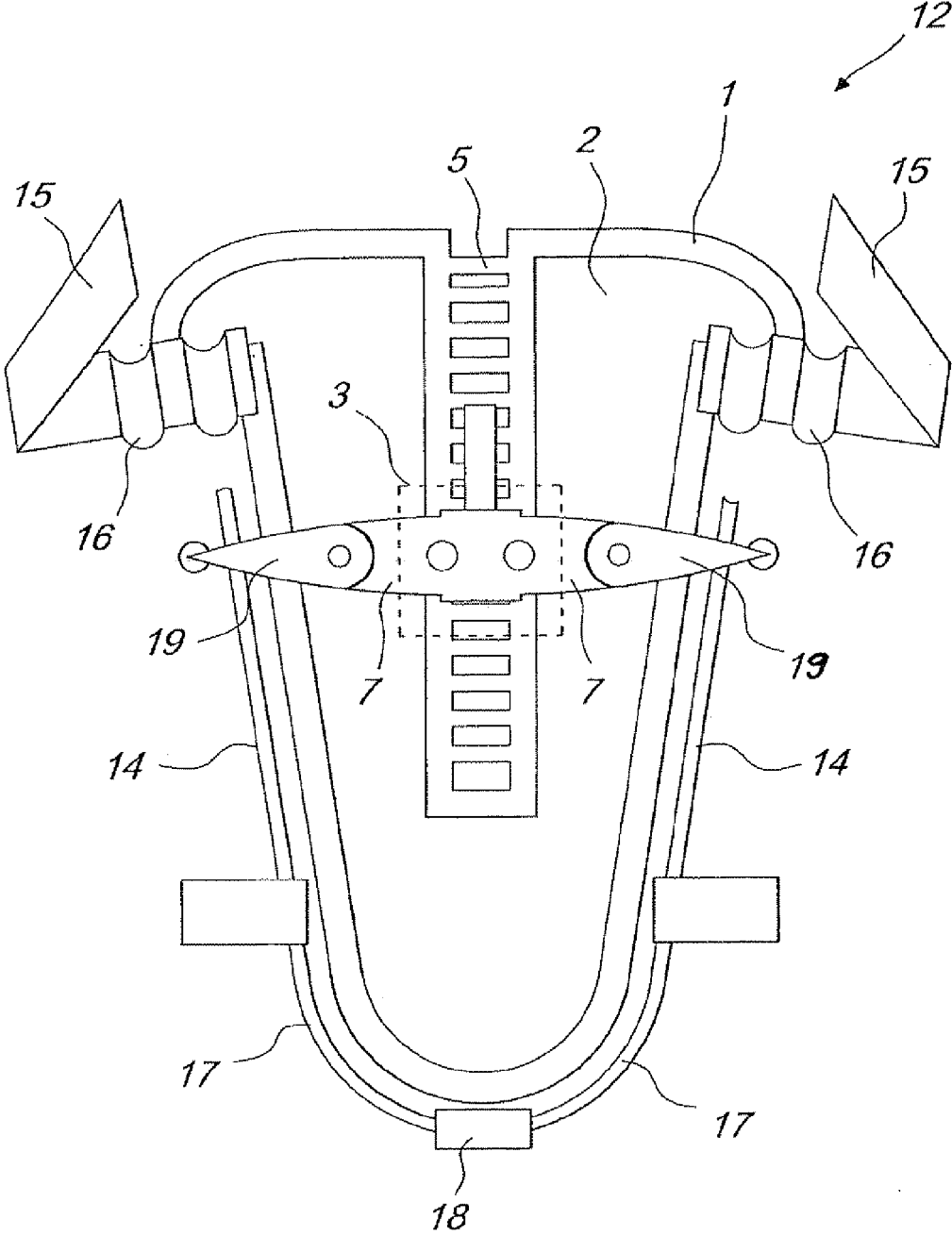

Fig. 4

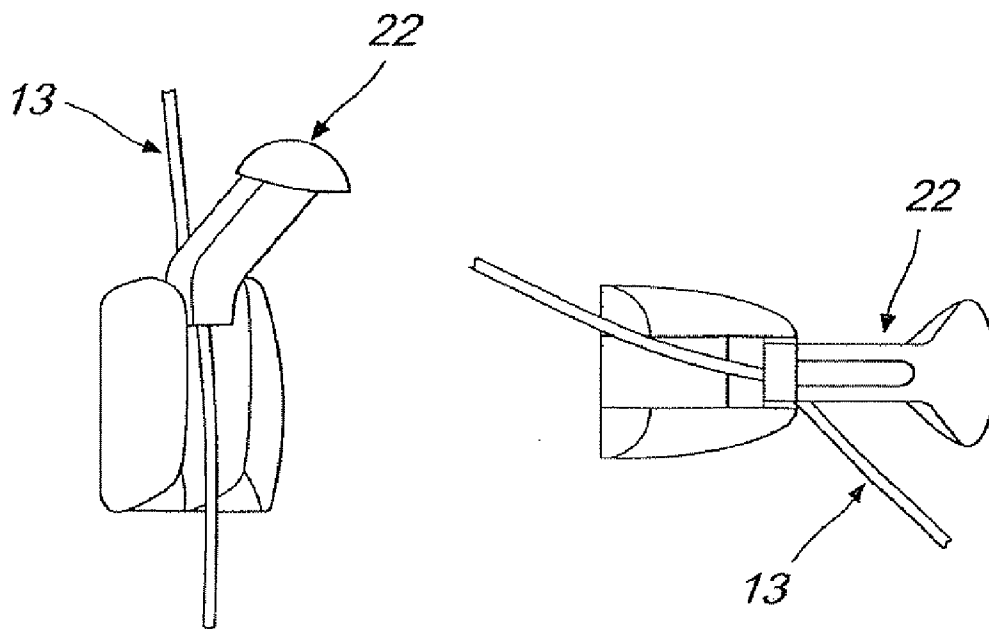

Fig. 5A

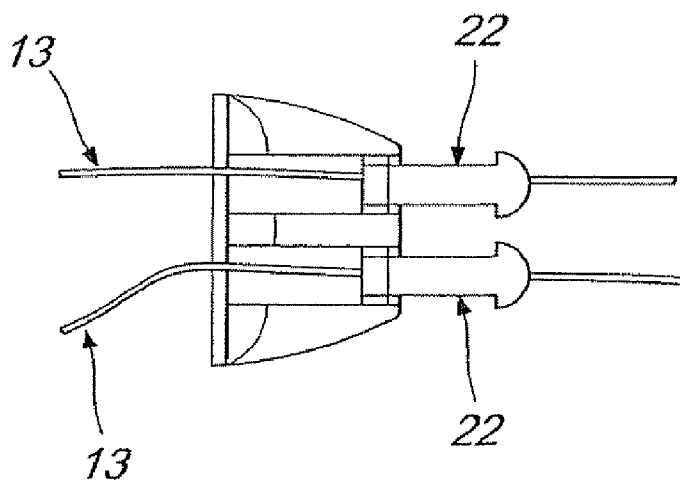

Fig. 5B

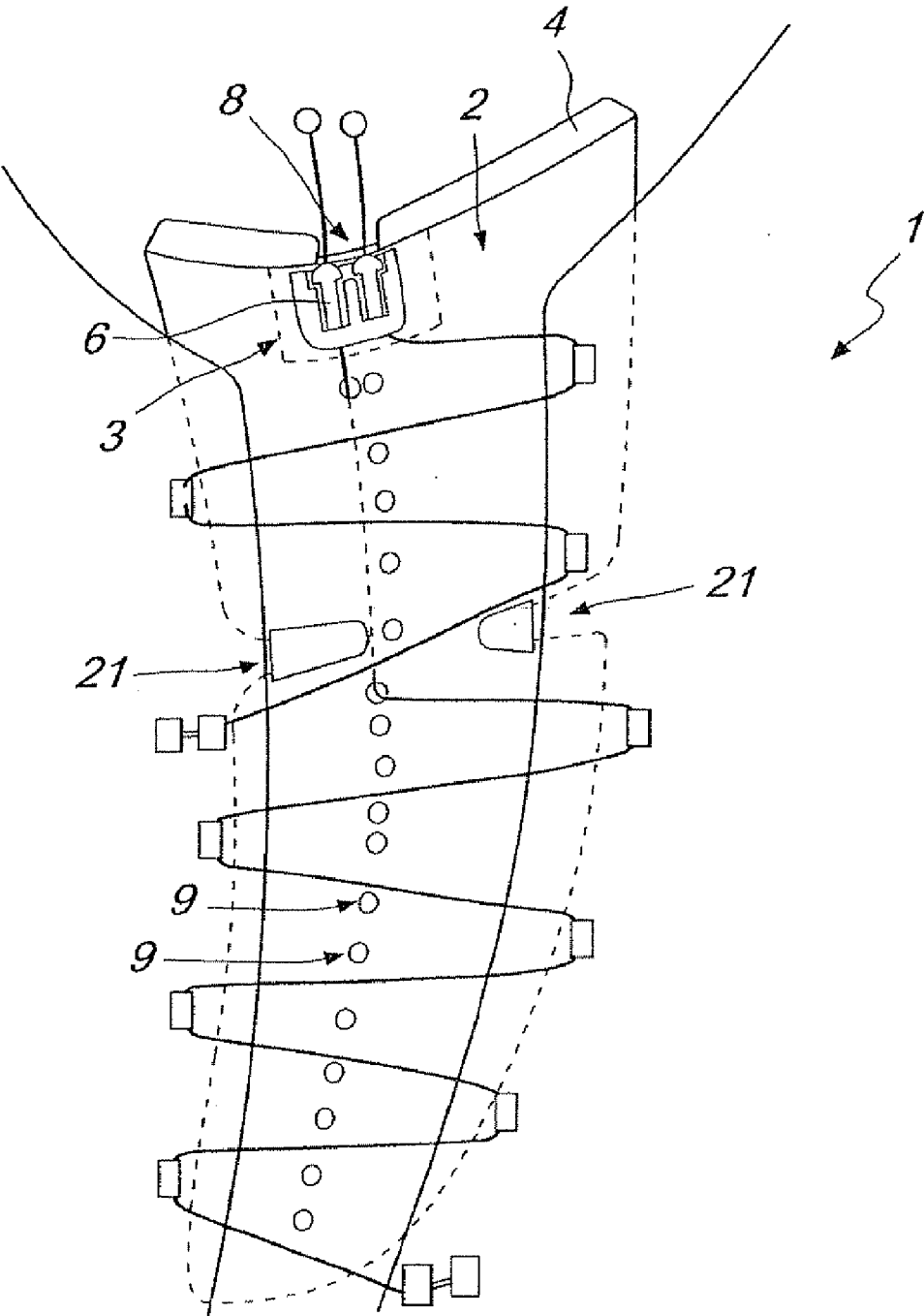

Fig. 6

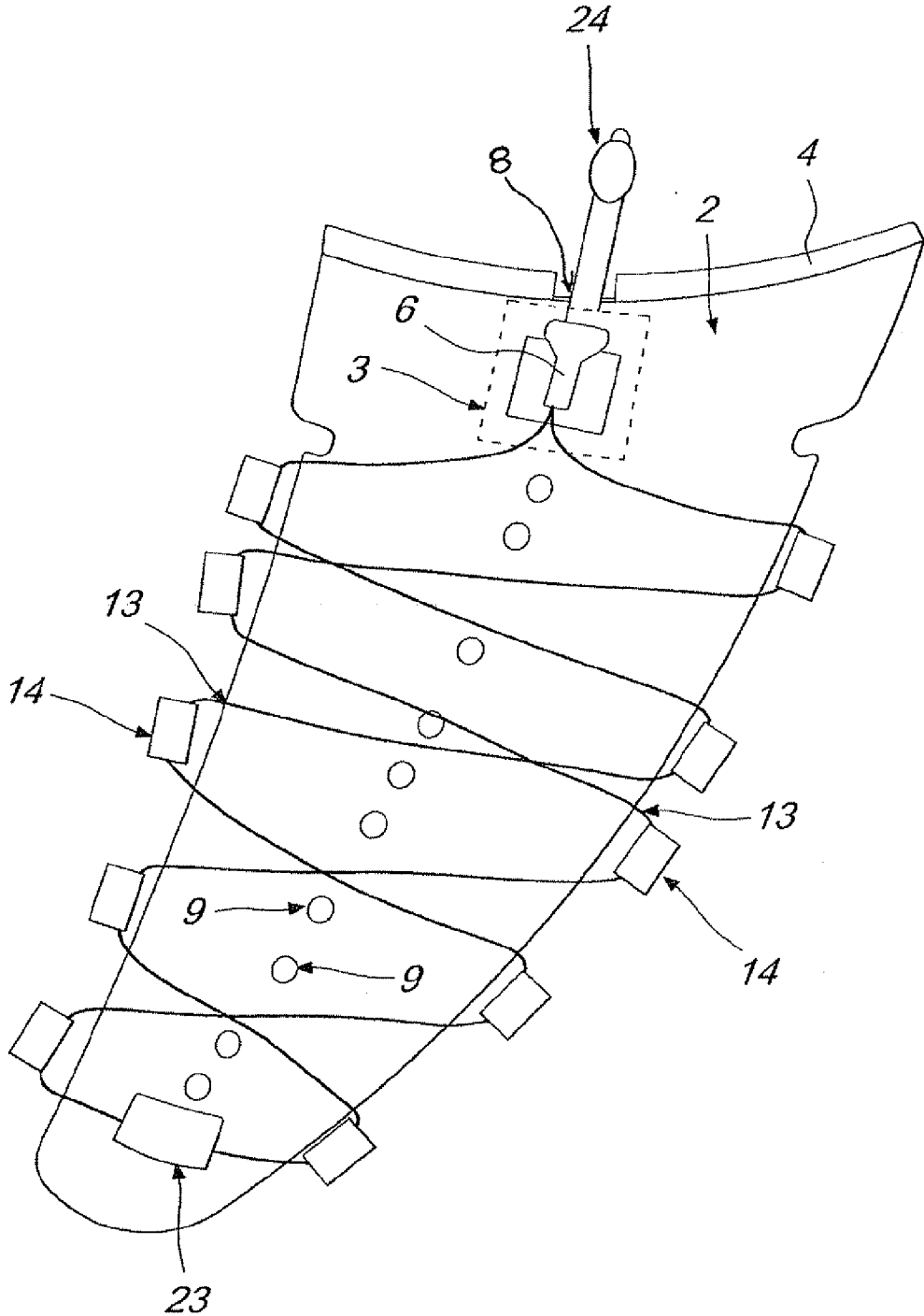

Fig. 7A

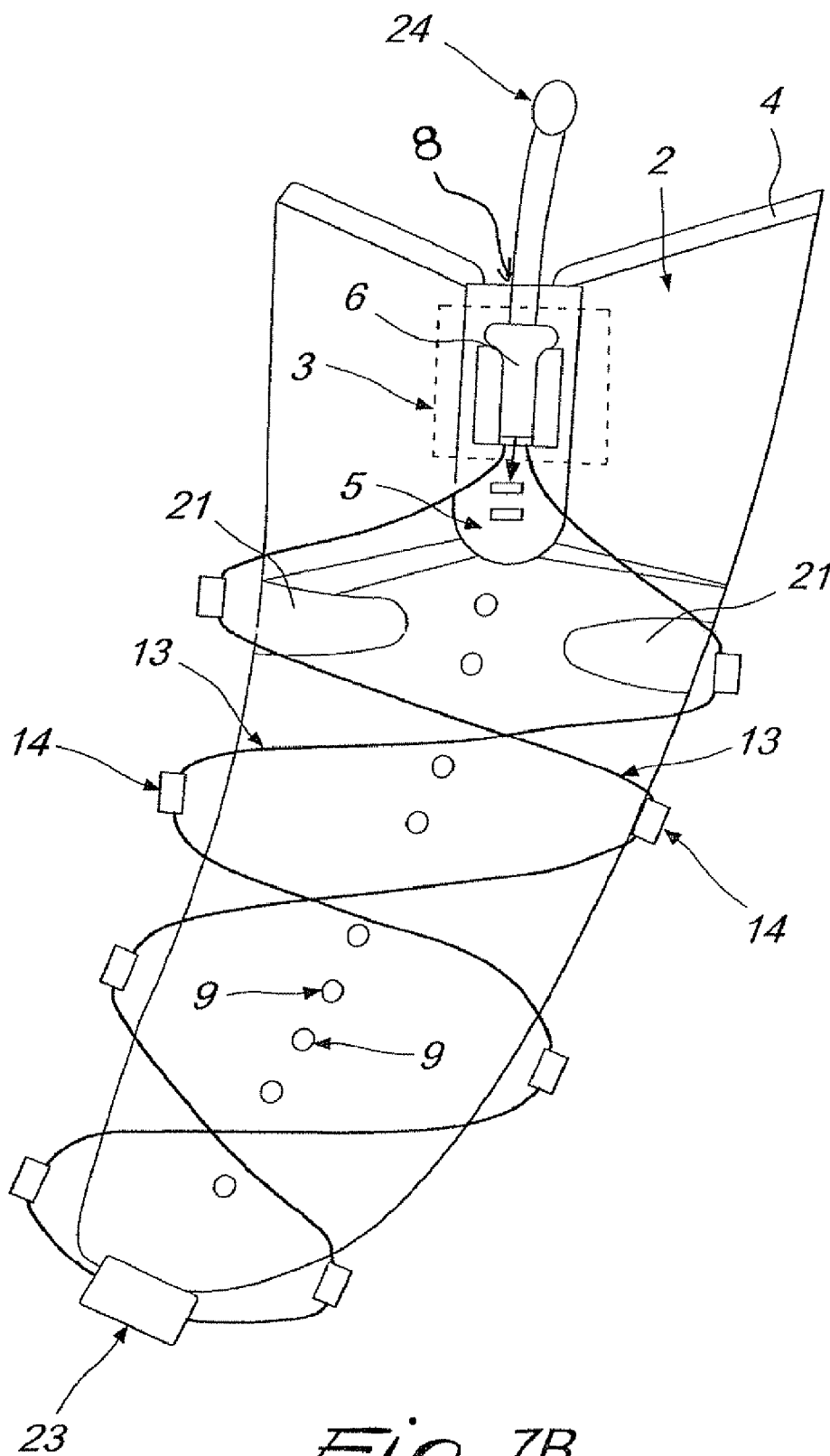

Fig. 7B

TONGUE AND INTERLOCKING SYSTEM FOR SHOES

[0001] The present invention refers to a new tongue or a new closing system for shoes, respectively.

[0002] The disadvantages of the state of the art of closing systems for shoes are as follows.

[0003] Existing tongues or closing systems, respectively, do not sufficiently take into account the anatomy of the dorsum of a foot or of the foot itself in terms of a continuous form-fit and an even distribution of pressure.

[0004] In addition, the closing systems for shoes which are known from the state of the art are tedious to handle and the components of existing closing systems are normally integral parts of the systems so that in case of any defects of the components, further use of the shoe is often impossible and a new purchase becomes necessary.

[0005] The task of the present invention is therefore to provide a closing system for shoes by means of which the above-mentioned disadvantages of the state of the art can be overcome and which provides an easy-to-use closing system for shoes whereat the shoe is opened completely.

[0006] Another task of the present invention is to provide a tongue for shoes which improves operability of a closing system for shoes.

[0007] An additional task of the invention is to provide a tongue for shoes which ensures good form-fit and an even distribution of pressure over the foot.

[0008] This and other tasks to be found in the following description are achieved by means of a tongue according to Claim 1 or by means of a closing system according to Claim 10, respectively, comprising a tongue according to Claim 1.

[0009] Advantageous further developments of the invention are indicated in the dependent claims.

[0010] In a first aspect, the present invention refers to a tongue for shoes which comprises a basic structure, a retaining device and a padding. The basic structure consists of a substantially non-elastic material and has a top side facing away from a foot and a bottom side facing the foot. The retaining device is positioned at the top side of the basic structure and formed such that it can fixedly accommodate at least one tie. The padding is provided at the bottom side of the basic structure. In principle, a two-layered tongue is formed in this way. A multi-layered embodiment of the tongue with further elements as paddings or having other functions is also conceivable.

[0011] In one embodiment, the retaining device for a cord or the tie, respectively, can be attached at a predefined site at the top side of the basic structure.

[0012] In another embodiment, a passage can be provided at the top side of the basic structure. In this embodiment, the retaining device can be located in the passage. The passage can further contain means for receiving the retaining device. Alternatively, the retaining device can comprise means for the accommodation in the passage. A combination of the above-mentioned means for the accommodation is possible as well. Furthermore, the means for the accommodation allow a positioning of the retaining device in the passage at defined intervals. Alternatively, continuously adjustable positioning of the retaining device in the passage can be provided.

[0013] In another embodiment, the adjustable positioning of the retaining device can take place at any site in the passage at suitable intervals, preferably intervals of 2.5 mm.

[0014] In another embodiment, the retaining device includes at least one Tanka. As used herein, a Tanka is a type of closure comprising a pivoted lever by means of which a tie such as a band or a cord can be clamped and thus fixed in the retaining device. As an alternative to the Tankas, the retaining device includes at least one seat for gripping arms. The use of a clamping lid, triple grouser or equivalent devices is conceivable as well as long as it can be used for a suitably fix and release of the tie into place in the retaining device. The use of conventional Tankas is conceivable as well, whereat a conventional Tanka is a generally longitudinal, rectangular device with a hole for the tie to be passed through it, which can then be fixed into place or released by pressing on a spring mounted bolt passed transversely through the hole. The use of round conventional Tankas is also conceivable.

[0015] According to the invention, the padding can be such that a cavity is formed. For example, the padding of the tongue can take place only at sides so that the cavity is formed in the middle of the tongue. Furthermore, the extension of the cavity can follow the dorsum of a foot.

[0016] In another embodiment, a plurality of perforations can be provided in the tongue. Further, the plurality of the perforations can especially be provided above the cavity. The perforations make it very easy for water vapor to escape, effectively improving the climate of the foot.

[0017] In another embodiment, an inlet opening and an outlet opening for passing through a tie can be provided in the basic structure such that the tie can be passed through between the inlet opening and the outlet opening at the bottom side of the basic structure and in the cavity.

[0018] In another embodiment, the tongue can be preformed, to the left and to the right, according to the anatomy of the dorsum of the foot.

[0019] In the above embodiments according to the first aspect of the invention, the tongue can comprise a one-membered structure or a multi-membered structure.

[0020] In the above embodiments according to the first aspect of the invention, the substantially non-elastic material of the basic structure can be a plastic. As the plastic, especially extruded polyurethane is preferred. By use of a substantially non-elastic material for the basic structure of the tongue, a form-fit along the entire portion of the tongue from the distal to the proximal side can be ensured in subsequent use of the tongue as part of the closing system. Thus, significant improvement of the fit of the tongue or of the closing system including the tongue, respectively, is possible. Further, in this manner, the pressure can be distributed evenly over the entire tongue. As mentioned previously, by adaption to the anatomy of the dorsum of the foot, the tongue can be completely supported by the foot. By means of the embodiment of the tongue, displacement can be minimized or entirely prevented, additionally improving the fit.

[0021] In a second aspect, the present invention is directed to a closing system for shoes which includes a tongue, at least one tie and guiding elements. The tongue is embodied according to the above-mentioned first aspect of the invention. The guiding elements for the at least one tie are provided on at least one side of the shoe-upper. The at least one tie engages with the guiding elements above the tongue. Further, the at least one tie is received fixedly in the retaining device according to the preceding first aspect of the invention.

[0022] The at least one tie can be selected from bands, cords and gripping arms. The guiding elements can be selected from eyelets, hooks and bars.

[0023] In one embodiment, the retaining device can be provided at a predefined site at the proximal end of the tongue. The retaining device can further include two Tankas as described above. The padding can be embodied such that the cavity is formed. In the basic structure, the inlet opening and the outlet opening for passing through a tie can be provided in such a way that the tie can be passed through between the inlet opening and the outlet opening at the bottom side of the basic structure and in the cavity. Two ties in the form of cords can be provided such that two-part or two-zone tying is created, wherein the distal cord extends substantially above the distal portion of the tongue and the proximal cord extends substantially above the proximal portion of the tongue. For bridging the portion of the proximal cord, the distal cord can be introduced in the inlet opening, passed through at the bottom side of the tongue and in the cavity and passed through at the outlet opening after bridging the portion of the proximal cord. By this two-part or two-zone tying, continuous form-fit from the distal to the proximal side can be ensured.

[0024] In another embodiment, the guiding elements can be formed as eyelets and/or hooks. Further, the proximal guiding elements can be provided at a distance of approximately 1.5 cm from the retaining device in the distal direction. The proximal guiding elements cannot be set at the same height as the retaining device. This distance of approximately 1.5 cm can ensure an evenly distributed tension.

[0025] In another embodiment, the retaining device can be located in the passage. Furthermore, the two guiding elements in the form of the bars can extend from the proximal to the distal end on the left and on the right shoe-upper and be located in proximal and distal seats.

[0026] In another embodiment, adjusting devices for adjusting the position of at least one of the two bars can be provided at the proximal and/or distal seats.

[0027] In another embodiment, a respective cartridge can serve as a proximal seat. The cartridge can further include one or more notches for fixing the bar into place. The notches can be provided in the diameter of the bars. For instance, 2 to 3 notches each can be provided in one cartridge. Thus, the bars can be fixed into place, for instance, in 2 to 3 positions and the angle between the bars can be enlarged or diminished, respectively. With this advantageous embodiment, different anatomies of feet can be accounted for. For instance, in case of a very broad foot, as a rule the last position of the bars towards the middle can be used.

[0028] In another embodiment, a flexible element can be used as the distal seat, which element can be deformed in all directions as desired. The flexible element can include an adjusting screw and be optionally provided in two parts. Furthermore, the flexible element can interconnect the bars by forming e.g. a curve. With the adjusting screw, it is possible to alter the position of the two bars, for instance, in relation to each other. For instance, the bars can be set parallel to each other by means of the adjusting screw or converging in an acute angle from the proximal to the distal end.

[0029] In another embodiment, the two ties in the form of ribbons can be provided such that concertina-like tying is created wherein the position of the two cords above the tongue can be adjusted in the proximal and/or the distal direction on the two bars by moving the retaining device. The further the retaining device is shifted from distal to proximal, the more the closing system, and therefore the shoe, can be closed. It is further preferred for the cords themselves to be

adjustable in length as desired. Thus, a continuous form-fit from distal to proximal can be ensured also in this embodiment.

[0030] In another embodiment, the two ties in the form of gripping arms can be provided such that a mechanism is created wherein the position of the two gripping arms above the tongue at the two bars can be adjusted by moving the retaining device into the proximal and/or the distal direction. The further the retaining device is shifted from distal to proximal, the more the closing system, and therefore the shoe, can be closed. Thus, a continuous form-fit from distal to proximal can be ensured also in this embodiment.

[0031] In the preceding embodiments according to the second aspect of the invention, in the case of bands and/or cords as ties, a fixed connection of the tie with the shoe-upper can be provided by anchoring at a predefined position. Further, the anchoring can optionally be adjustable.

[0032] In a third aspect, the present invention is directed toward the tongue for shoes according to the first aspect or toward the closing system for shoes according to the second aspect, respectively, where all components of the tongue or of the closing system, respectively, can be replaced. Thus, if any of the components according to the invention are defective, further use of the shoe can be ensured. Furthermore, it is envisaged that certain components can be replaced by the user himself.

[0033] In the following, there is a detailed description of the invention using preferred embodiments and the enclosed drawings wherein:

[0034] FIG. 1 is a schematic drawing of an embodiment of a tongue according to the present invention;

[0035] FIG. 2 is a schematic drawing of an embodiment of a closing system according to the present invention;

[0036] FIG. 3 is a schematic drawing of a further embodiment of a closing system according to the present invention;

[0037] FIG. 4 is a schematic drawing of another embodiment of a closing system according to the present invention;

[0038] FIG. 5A is a schematic drawing of a single Tanka with a pivoted lever by means of which a tie, such as a band or a cord, can be clamped and thus fixed into place in the retaining device;

[0039] FIG. 5B is a schematic drawing of a double Tanka with a mechanism of the levers which is analogous to FIG. 5A;

[0040] FIG. 6 is a schematic drawing of a tongue with a two-membered structure;

[0041] FIG. 7A is a schematic drawing of another embodiment of a closing system according to the present invention, and

[0042] FIG. 7B is a schematic drawing of yet another embodiment of a closing system according to the present invention.

[0043] In FIG. 1, a schematic drawing of an embodiment of a tongue 1, here symmetrical to the longitudinal axis, according to the present invention is shown. Preferably, the tongue 1 is coated with the same material as the shoe. The tongue 1 is shown with a basic structure 2 and a padding 4. A retaining device is not shown here for the sake of a better visibility of the basic structure 2. The basic structure 2 is made of extruded polyurethane, a substantially inelastic, i.e. rigid plastic. This material ensures that when the closing system is closed, the tongue rests on the foot with form-fit over the entire contact surface. Further, the top side of the basic structure 2, facing away from a foot, can be seen. The bottom side facing the foot

is not visible in FIG. 1. The padding 4 is shown at the bottom side of the basic structure 2 in a narrow area. A passage 5 is displayed at the top side of the basic structure 2. Within the passage 5, means for receiving the retaining device 3 not shown here are indicated. The displayed receiving means allow a positioning of the retaining device 3 in the passage 5 which can be adjusted in defined intervals. Here, the adjustable positioning corresponds approximately to intervals of 2.5 mm. The padding 4 is here such that a cavity 8 is produced. Here, the padding 4 of the tongue 1 is produced only at the sides so that the cavity 8 is created in the middle of the tongue 1. Furthermore, a plurality of perforations 9 is shown. Here, the plurality of perforations 9 is formed above the cavity 8. These perforations 9 make it possible for water vapor to escape very easily, effectively improving the climate of the foot. The tongue 1 here is shown as a one-membered structure. A tongue with a two-membered structure is shown in FIG. 6, where the two members are implemented with a hinge-like device 21 on the interface between the dorsum of the foot and the shin. The two-membered tongue shown in this figure is displayed with two-part or two-zone tying (see FIG. 2) explained in the following. However, use of a two-membered structure is not to be limited to the shown embodiment with two-zone tying but can also be used with other embodiments which are explained subsequently. Such a two-membered tongue is preferably provided for footwear which covers the ankles.

[0044] As already mentioned previously, by using extruded polyurethane for the basic structure 2 of the tongue 1, a form-fit over the entire portion of the tongue 1 from distal to proximal can be ensured during later use of the tongue 1 as part of the closing system. In this way, a fit of the tongue or of the closing system, respectively, can be substantially improved. Furthermore, therewith the pressure can be distributed evenly over the entire tongue.

[0045] In FIG. 2, a schematic drawing of an embodiment of a closing system according to the present invention is shown. The closing system 12 is shown with a tongue 1. The retaining device 3 (dashed-lined square) is shown in the middle of the proximal end of the tongue 1. Here, the retaining device 3 contains a double Tanka 6. The Tankas preferably used are shown in FIGS. 5A and 5B. FIG. 5A shows a single Tanka 6 provided with a pivoted lever 22 by means of which the tie 13, such as a band or cord, can be clamped and thus fixed into place in the retaining device 3. FIG. 5B shows a double Tanka with a mechanism of the levers which is analogous to FIG. 5A. The double Tanka contains two adjacent pivoted levers 22 which can be operated independently of one another. Double Tankas are used preferably with two-zone tying.

[0046] The basic structure 2 contains an inlet opening 10 and an outlet opening 11 for passing through a distal cord 13_d which is passed through between the inlet opening 10 and the outlet opening 11 at the bottom side of the basic structure 2 (dashed line) and in the cavity 8 (not shown). Further, a proximal cord 13_p is shown, producing two-part or two-zone tying where the distal cord 13_d extends substantially above the distal portion of the tongue 1 and the proximal cord 13_p extends substantially above the proximal portion of the tongue 1. The distal cord 13_d thus bridges the portion of the proximal cord 13_p. The distal cord 13_d and the proximal cord 13_p are each inserted into one of the Tankas 6. Furthermore, eyelets 14 to the left and to the right of the shoe-upper S are shown in which the cords 13 are inserted. The proximal eyelets 14_p are arranged at a distance of approximately 1.5 cm

from the retaining device 3 in the distal direction so as to cause an even tension at this distance. Further, the cords 13 are shown in a fixed connection with the shoe-upper S due to a respective anchoring 20. This two-part or two-zone tying ensures a continuous form-fit from distal to proximal.

[0047] In FIG. 3, a schematic drawing of another embodiment of a closing system according to the present invention is shown. The closing system 12 is drawn with a tongue 1. The retaining device 3 (dashed-lined square) is shown in the center of the tongue 1 in the passage 5. Here, the retaining device 3 comprises one single Tanka 6. In the passage 5, means for receiving the retaining device 3 are shown. The displayed receiving means allow a positioning of the retaining device 3 in the passage 5 which can be adjusted in defined intervals. Here as well, positioning can be adjusted in steps of approximately 2.5 mm. Furthermore, two bars 14 at the left and the right shoe-upper (not shown) are presented which extend from proximal to distal and are each arranged in proximal and distal seats.

[0048] Here, a left and a right cartridge 15 are shown as proximal seats. The cartridges 15 each have two notches 16 for fixing the bars 14 into place. Here, the notches 15 are represented substantially in the diameter of the bars 14. Thus the bars 14 can each be fixed in 2 positions and the angle between the bars 14 can be enlarged or reduced.

[0049] As already mentioned above, with this advantageous embodiment different anatomies of feet can be taken into account. Furthermore, for a distal seat a flexible element 17 is represented which can be deformed in all directions. The flexible element 17 is advantageous for a rolling motion of the foot during walking. The flexible element 17 has an adjusting screw 18 and is divided at the center into two halves by the adjusting screw 18. Here, the flexible element 17 interconnects the bars 14 by forming a curve. By means of the adjusting screw 18, the relation of the two bars 14 to each other is set in such a way that they converge at an acute angle from proximal to distal. Furthermore, two cords 13 are arranged such as to cause a concertina-shaped tying wherein the position of the two cords 13 above the tongue 1 is set at both bars 14 by moving the retaining device 3 in the proximal and/or distal directions. The more the retaining device 3 is shifted from distal to proximal, the more the closing system 12 and thus the shoe are closed. Also, the two cords 13 are introduced in the Tanka 6. Furthermore, the cords 13 themselves can be adjusted in length. Also, the cords 13 are shown in a fixed connection with the shoe-upper due to a respective anchoring 20. As mentioned previously, continuous form-fit from distal to proximal is thus ensured in this embodiment as well.

[0050] In FIG. 4, a schematic drawing of another embodiment of a closing system according to the present invention is shown. The closing system 12 is shown comprising a tongue 1. The retaining device 3 (dashed-lined box) is shown in the center of tongue 1 in the passage 5. Here, the retaining device 3 comprises one seat 7 for one gripping arm each. In the passage 5, means for receiving the retaining device 3 are shown. The displayed receiving means allow a positioning of the retaining device 3 in the passage 5 which can be adjusted at defined intervals. Here as well, the adjustable positioning corresponds to steps of approximately 2.5 mm. Furthermore, two bars 14 on the left and the right shoe-upper (not shown) are displayed which extend from proximal to distal and are each arranged in proximal and distal seats. Here, a left and a right cartridge 15 are shown as proximal seats. The cartridges 15 comprise two notches 16 each for fixing the bars 14 into

place. Here, the notches **15** are substantially shown in the diameter of the bars **14**. Thus, the bars **14** can be fixed in two positions and the angle between the bars **14** can be enlarged or reduced. As mentioned previously, with this advantageous embodiment different anatomies of the feet can be accounted for. Further, a flexible element **17** is shown here as a distal seat which can be deformed in all directions. The flexible element **17** has an adjusting screw **18** and is divided at the center into two halves by the adjusting screw **18**. Here, the flexible element **17** interconnects the bars **14** by forming a curve. With the adjusting screw **18**, the position of the two bars **14** in relation to each other is set such that they converge at an acute angle from proximal to distal. Furthermore, two gripping arms **19** are arranged such as to produce a mechanism wherein the position of the two gripping arms **19** above the tongue **1** is adjusted at the two bars **14** in the proximal and/or the distal direction by moving the retaining device **3**. The further the retaining device **3** is shifted from distal to proximal, the more the closing system **12** and thus the shoe is closed. As mentioned above, continuous form-fit from distal to proximal is ensured in this embodiment as well.

[0051] In FIGS. 7A and 7B, schematic drawings of yet other embodiments of a closing system according to the present invention are shown wherein the presented variants can be used with a one-membered or a two-membered tongue. These variants are especially suited for children's shoes because of easier handling. FIG. 7A uses a one-membered tongue which is usable with what are called "low-cut shoes". FIG. 7B uses a two-membered tongue which is advantageous with shoes covering the ankles, wherein the Tanka **6** in this variant can be shifted a little towards the top or towards the bottom in the passage **5**. In both variants of FIGS. 7A and 7B, the cords **13** can be interconnected by a fixation device **23** at the distal end or at the bottom of the shoe-upper, respectively. Further, the fixation device **23** itself can be fixed permanently to the shoe-upper. The fixation device **23** can include two metal or plastic platelets which are screwed to each other and to which the cords are attached. A correspondingly formed Tanka is also possible as a fixation device **23**. In both variants, in FIGS. 7A and 7B, the cords **13** can be provided with a gripping aid **24** at the proximal end.

[0052] The advantages achieved with the present invention can be summarized as follows:

[0053] With the embodiment of the tongue according to the invention, an operability of the closing system is facilitated.

[0054] With the embodiment of the tongue in terms of material and shape according to the invention and with the embodiment of the closing system according to the invention, the continuous form-fit and the even distribution of pressure along the entire portion of the tongue from distal to proximal can be ensured.

[0055] Due to the provision of the perforations according to the invention which are preferably provided above the cavity, the water vapor can escape very easily and the climate of the foot can be effectively improved.

[0056] Due to the provision of replaceable components of the tongue or of the closing system, further use of the shoe can be ensured in case of any defects of the components according to the invention.

[0057] Thus, with the present invention an easy-to-implement, inexpensive and resource-saving closing system for the shoes with excellent and continuous form-fit and the even distribution of pressure is provided.

List of reference numbers

1	tongue	13	tie/cord
2	basic structure	13p	proximal cord
3	retaining device	13d	distal cord
4	padding	14	guiding element/eyelet/bar
5	passage	14p	proximal eyelet
6	Tanka	15	proximal seat/cartridge
7	seat for gripping arm	16	notches
8	cavity	17	flexible element
9	perforations	18	adjusting screw
10	inlet opening	19	gripping arm
11	outlet opening	20	anchoring
12	closing system	22	pivoted lever
21	hinge-like device	23	fixation
		24	gripping aid
		S	shoe-upper

1-22. (canceled)

23. Tongue for shoes comprising:

a basic structure of an essentially non-elastic material, having a top side facing away from a foot and a bottom side facing the foot;

a retaining device on the top side of the basic structure, wherein the retaining device is structured such that it can fixedly accommodate at least one tie, wherein the fixing is achieved by means of clamping; and

a padding at the bottom side of the basic structure, wherein the basic structure is designed such that across the entire contact surface, the tongue can lie form-fittingly on the foot, and that both on the right and the left side, the tongue is preformed according to the anatomy of the dorsum of the foot, and wherein

in the tongue a plurality of perforations is provided.

24. Tongue according to claim 23, wherein the padding is such that a cavity is created and the extension of the cavity follows the dorsum of the foot.

25. Tongue according to claim 25, wherein the plurality of the perforations is provided above the cavity.

26. Tongue according to claim 23, further comprising a passage at the top side of the basic structure, wherein the retaining device is arranged in the passage, the passage has means for accommodating the retaining device and/or the retaining device has means for being accommodated in the passage, and

the means for accommodating or the means to be accommodated allowing a positioning adjustable in defined intervals or a continuously adjustable positioning of the retaining device in the passage.

27. Tongue according to claim 26, wherein the adjustable positioning of the retaining device takes place at any position in the passage in intervals of 2.5 mm.

28. Tongue according to claim 23, wherein the retaining device comprises at least one Tanka.

29. Tongue according to claim 24, wherein in the basic structure an inlet opening and an outlet opening for passing through the tie are provided such that the tie is passed through between the inlet opening and the outlet opening on the bottom side of the basic structure and in the cavity.

30. Tongue according to claim **23**, where the tongue has a one-membered structure or a multi-membered structure.

31. Tongue according to claim **23**, wherein the essentially non-elastic material of the basic structure is plastic, in particular extruded polyurethane.

32. Closing system for shoes comprising:
a tongue according to claim **23**,
at least one tie and

guiding elements for the at least one tie on at least one side of a shoe-upper in which the at least one tie engages above the tongue, wherein in addition the at least one tie is fixedly received in a retaining device.

33. Closing system according to claim **32**, wherein the at least one tie is selected from bands, cords and gripping arms.

34. Closing system according to claim **32**, wherein the guiding elements are selected from eyelets and hooks.

35. Closing system according to claim **32**, wherein the retaining device is attached in a predefined position at a proximal end of the tongue and comprises two Tanks, the padding is embodied such that a cavity is created, in the basic structure, an inlet opening and an outlet opening for passing through the tie are provided such that the tie is guided through between the inlet opening and the outlet opening at the bottom side of the basic structure and in the cavity, and

two ties having the form of cords are provided such that a two-part tying is created wherein a distal cord extends substantially above the distal portion of the tongue, a proximal cord extends substantially above the proximal portion of the tongue and the distal cord is inserted into the inlet opening for bridging the portion of the proximal cord, is passed through at the bottom side of the tongue and in the cavity and is passed out of the outlet opening after bridging the portion of the proximal cord.

36. Closing system according to claim **35**, where the guiding elements are formed as eyelets and/or hooks and the

proximal guiding elements are arranged at a distance of approximately 1.5 cm in the distal direction from the retaining device.

37. Closing system according to claim **32** wherein the retaining device is arranged in the passage, and two guiding elements having the form of bars extend from proximal to distal at the left and the right shoe-upper and are arranged in proximal and distal seats.

38. Closing system according to claim **37**, wherein at the proximal and/or the distal seats adjustment devices for adjusting the position of at least one of the two bars are provided.

39. Closing system according to claim **38**, wherein as the proximal seats one respective cartridge is used which comprises one or more notches for fixing the bar into place.

40. Closing system according to claim **37**, where as a distal seat a flexible element is used which comprises an adjusting screw and interconnects the bars.

41. Closing system according to claim **37**, wherein the two ties in the form of cords are provided such that a concertina-like tying is produced where the position of the two cords above the tongue is adjusted at the two bars by moving the retaining device in the proximal and/or the distal direction, and

the cords are provided such that their length is adjusted as desired in the retaining device.

42. Closing system according to claim **32**, wherein in the case of bands and/or cords as the ties, a fixed connection of the tie with the shoe-upper is provided at a predefined position by means of anchoring and wherein the anchoring can optionally be adjusted.

43. Tongue for shoes according to claim **23**, wherein all components of the tongue are replaceable.

44. Closing system for shoes according to claim **32**, wherein all components of the closing system are replaceable.

* * * * *