

- [54] **SANDWICH PANEL INSERT AND INSTALLATION HOLDER ASSEMBLY AND METHOD OF HANDLING**
- [75] Inventors: **George H. Wright, Orange; Charles S. Phelan, Tustin, both of Calif.**
- [73] Assignee: **Shur-Lok Corporation, Santa Ana, Calif.**
- [22] Filed: **Sept. 21, 1970**
- [21] Appl. No.: **73,813**
- [52] U.S. Cl. **206/65 K, 52/704, 206/46 H**
- [51] Int. Cl. **B65d 75/06, B65d 85/62**
- [58] Field of Search **206/65 R, 65 K, 46 H, 56 AC, 206/56 A; 52/704; 229/51 S; 264/262; 151/41.73**

3,124,249 3/1964 Flashman.....206/65 K

FOREIGN PATENTS OR APPLICATIONS

390,113 3/1933 Great Britain206/56 AC

Primary Examiner—William T. Dixson, Jr.
Attorney—Lynn H. Latta

[57] **ABSTRACT**

A column of sandwich panel inserts each attached to a respective holding tab by a coating of adhesive subsequently operative to attach the tab and insert to a sandwich panel. The insert and tab units are held in coaxial assembly by a wire stringer of hairpin form having respective legs received in peripheral notches in the radial flange heads of the insert, which notches are utilized for injection of potting compound into a hole in a sandwich panel in which the insert is positioned by the tab. The column of inserts and tabs is enclosed in a dust-proof casing having an opener thread for slitting its side for removal of the insert-tab units.

[56] **References Cited**

UNITED STATES PATENTS

- 3,392,225 7/1968 Phelan.....264/262
 1,768,203 6/1930 Kole.....229/51 S

4 Claims, 5 Drawing Figures

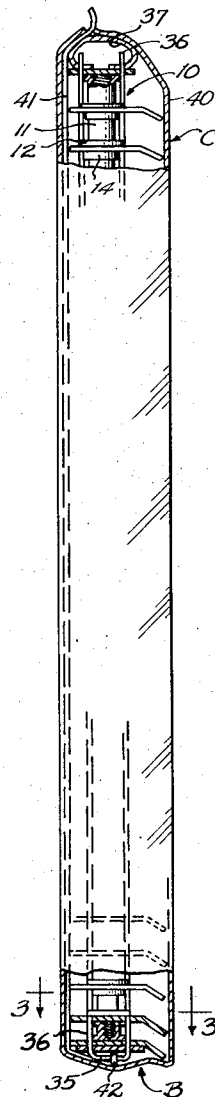

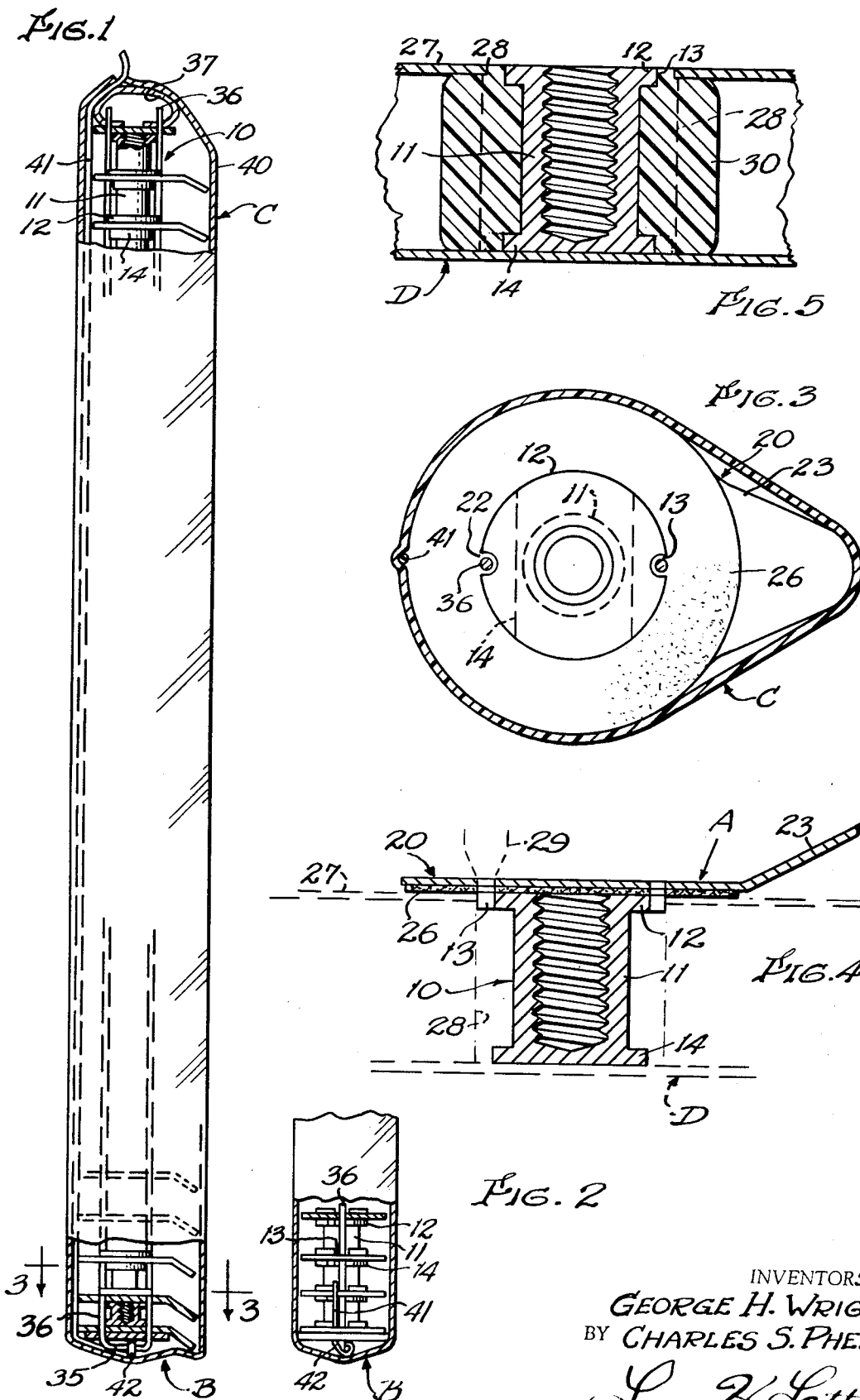

INVENTORS
GEORGE H. WRIGHT
BY **CHARLES S. PHELAN**
Lynn P. Latta
ATTORNEY

SANDWICH PANEL INSERT AND INSTALLATION HOLDER ASSEMBLY AND METHOD OF HANDLING

BACKGROUND OF THE INVENTION

Panel inserts anchored in lightweight sandwich panels by potting compound surrounding the insert and filling a hole in the panel receiving the insert, have been widely used for over ten years past, especially in the air-frame industry where such panels are used to reduce weight. An initial stage in the development of such panel-insert assemblies is disclosed in Rohe' U.S. Pat. No. 2,880,830. A number of stages of improvement in such inserts and the methods of installation thereof are disclosed in the following U.S. Patents:

Rohe' 3,016,578

Rohe' 3,271,498

Rohe' 3,282,015

Rohe' et al. 3,417,803

A most recent stage of development utilizing an adhesive holding tab, prior to the present invention, is disclosed in the following U.S. Patents:

Phelan 3,392,225

Phelan 3,510,916

The holding tab disclosed in the aforesaid Phelan Patents is one having an adhesive coating covered by a thin sheet which is stripped off to expose the adhesive. The holding tab is then manually attached to the end face of an insert by pressing the latter against the central area of the adhesive coating after adjusting its position to bring a pair of apertures in the tab into registration with a pair of potting apertures or notches in the periphery of the insert head, leaving a marginal portion of the adhesive coating projecting radially beyond the periphery of the insert head for attachment to the face of a panel skin around the opening which receives the insert. The attachment of the tab to the insert in the proper position is a time consuming manual operation.

SUMMARY OF THE INVENTION

The present invention improves upon the above described system in providing a plurality of insert-tab units each having the tab pre-attached to the insert head in the proper position with its apertures registering with the potting notches in the insert head. The adhesive covering sheet previously used, is dispensed with. The adhesive is one that retains its tackiness over an extended period of time. The insert-tab units are assembled in a column of a common axis and are retained in such assembly by a wire stringer of hairpin form having opposed parallel legs extending through the tab apertures and the insert notches. The column is enclosed in a plastic casing which protects the adhesive coatings from becoming fouled by atmospheric dust, lint, etc. and which inhibits drying of the coatings. A quick-opening pull thread is embodied in the casing for rapid opening of the package.

OBJECTS OF THE INVENTION

The general object of this invention is to provide a packaged assembly of insert-tab units ready for instant use upon opening the package, eliminating the necessity for attachment of the tabs to the inserts by the workman at the time of installation of the inserts in a panel.

DESCRIPTION

This and other objects will become apparent in the following specifications and claims and appended drawings, in which:

FIG. 1 is a side view of a package embodying the invention, the ends of the package being broken away and shown in section;

FIG. 2 is a fragmentary front elevational and sectional view of the same;

FIG. 3 is a cross-sectional view thereof on an enlarged scale, taken on line 3—3 of FIG. 1;

FIG. 4 is an axial sectional view of one of the insert-tab units, on an enlarged scale, its insertion into a sandwich panel being indicated in phantom; and

FIG. 5 is a cross-sectional view of the insert installed in a sandwich panel.

Referring now to the drawing in detail, we have shown therein, as an example of the invention, a plurality of insert tab units A (FIG. 4) assembled in a column B (FIG. 1) which is enclosed in a casing C for handling, shipment and storage until ready for use. The insert of unit A is adapted for installation in a sandwich panel D. (FIG. 5).

Each insert-tab unit A comprises a fastener insert 10 and an applicator tab 20 having a central area adhesively attached to insert 10. Insert 10 is such as is shown, for example, in the aforesaid Rohe' Pat. No. 3,271,498, having an internally threaded nut body 11, a head 12 with injection ports or notches 13 at one end, and a blind head 14 with flatted sides at its other end. Tab 10 is of the type shown in Phelan Pat. No. 3,510,916 with the exception that it does not have an adhesive-covering sheet and its adhesive is of a type that will remain tacky for an extended period of time.

The tab comprises a circular disc body 21 having a pair of apertures 22 to register with the potting apertures 13 of insert head 12, a handle 23 at one side, and a coating 26 of adhesive covering the face of disc body 21 but not of handle 23. The diameter of disc body 21 is greater than that of insert head 12 to an extent such as to leave a broad ring of adhesive exposed beyond the periphery of head 12, for attachment to the outer face of a skin 27 of panel D, around the margin of a hole 28 in the panel which receives the insert, the head 12 of the insert being fitted in the mouth of the hole 28 in skin 27. The tab functions to hold the insert 10 in proper position in hole 28 during injection of potting material from a gun nozzle 29 (FIG. 4) through apertures 22 and 13 into hole 28 which becomes filled with the compound to provide an anchoring body 30 (FIG. 5) when the compound becomes set.

Column B is composed of a plurality of the insert-tab units A retained in coaxial assembly by a wire stringer 35 of hair pin form having spaced parallel legs 36 threaded through the tab apertures 22, straddling the flat sides of inset heads 14, and engaged in the insert head notches 13. At the head end of the package the free ends of stringer legs 36 are received in apertures in a spacer yoke 37 of C-shape, having an arched web portion overhanging the ends of the legs.

Casing C comprises a tubular body 40 of plastic or equivalent film material substantially impervious to air and moisture, preferably heat-sealable, shrunk around the column B, with sealed ends, one engaged against

the bridging end of stringer 35 and the other engaged against the arched portion of spacer yoke 37. An opener thread 41 has one end anchored at 42 to the bridging end of stringer 35, is extended along the wall 40 of casing C between the inner surface thereof and the edges of tabs 20, and has its other end 43 projected through the sealed end of casing C and adapted to be grasped to rip open the casing wall 40, full length, allowing the column E to be removed. The insert-tab units A are then released by removing the spacer yoke 37 and sliding the units A into a suitable tray from which the workman removes them one by one and inserts them into panel holes 28.

I claim:

1. An assembly of sandwich panel inserts and installation holders, comprising:

a plurality of panel inserts each having a fastener body and a head at one end of said body in the form of a radially projecting flange having circumferentially spaced apertures for injection of potting compound into a hole in a sandwich panel so as to surround the insert body received in said hole;

a plurality of installation holders each comprising a thin disc of larger diameter than said head, said disc having on one of its faces a central area adjoining the outer face of the head of a respective insert and a peripheral area which projects beyond said head for attachment to the outer face of the sandwich panel around the hole therein, for holding said insert in correct position in said hole during injection and hardening of the potting com-

pound, said disc having apertures registering with the apertures of the insert head;

a layer of adhesive attaching said central area of said disc to the opposed face of said head, said adhesive being such as to retain said disc in position on said head during handling and installation including said holding, and such as to permit release of said holder from said head when the insert is secured in said hole;

an adhesive coating of lasting tackiness on said peripheral area operable to effect said attachment to the panel and to permit release of the holder therefrom when the insert is secured to the panel; said inserts and holders being arranged in a coaxial column of insert-holder units in which the inserts and holders are in alternating arrangement and their respective apertures are aligned;

and a wire stringer means having laterally spaced legs received in the respective apertures and retaining said insert-holder units in said coaxial column.

2. An assembly as defined in claim 1, including a tubular casing enclosing said column, protecting the exposed surfaces of said adhesive coatings from becoming fouled, and inhibiting drying of said coatings.

3. An assembly as defined in claim 2, including a spacer yoke having spaced apertures receiving the free ends of said stringer legs and an arched central portion overhanging said ends and supporting the end of the casing out of contact therewith.

4. An assembly as defined in claim 1, said adhesive coating being an integral extension of said layer.

* * * * *

35

40

45

50

55

60

65