

May 2, 1961

V. HAUPTMANN

2,982,460

REINFORCING JOINT FOR A CONTAINER

Filed Oct. 8, 1957

FIG. 1

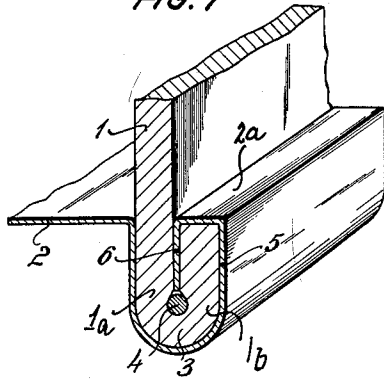

FIG. 2

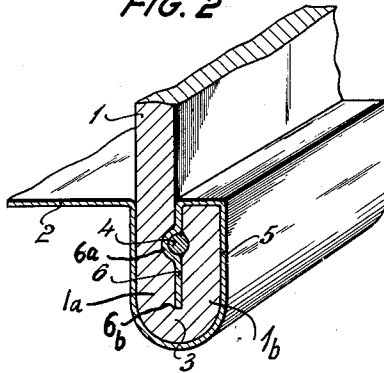
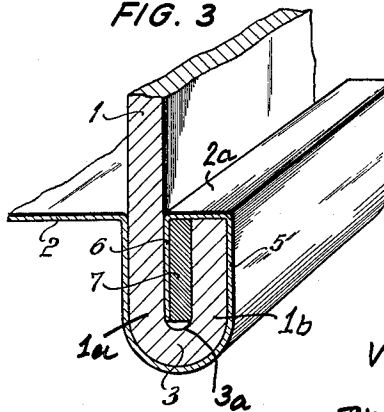

FIG. 3



INVENTOR

VINZENZ HAUPTMANN

BY *Leon M. Strauss*
ATT.

1

2,982,460

REINFORCING JOINT FOR A CONTAINER

Vinzenz Hauptmann, Koln-Ehrenfeld, Germany, assignor to Mauser Kommandit-Gesellschaft, Koln-Ehrenfeld, Germany, a German firm

Filed Oct. 8, 1957, Ser. No. 688,893

1 Claim. (Cl. 229—5.6)

The present invention relates to a reinforcing joint between a sheet metal base and a non-metallic foldable container portion, and more particularly to a fold connection between a metal base and the jacket of a container made of fiber, paperboard, or other non-metallic foldable material.

One well known method of forming a folded connection in such a container is to surround the fold around its outer periphery with a layer of sheet metal; this method results in completely surrounding the connection or fold portion of the paperboard or like jacket with a superimposed outer layer of metal. In such cases, the choice of thickness of the reinforcing metal base will be limited by the permissible degree of deformation of the end of the paperboard jacket when producing the fold connection under well known deforming conditions. Consequently, the metallic reinforcing cover is usually relatively thin and therefore insufficient to protect the container against breakage when subjected to great stress. Load and drop tests conducted using various materials have demonstrated that the known folded metal base spreads open when the edge of the base is struck, whereas the jacket material of the container remains stationary during the impact. As a consequence, leaks occur in the joints formed according to these methods of the prior art.

One method of overcoming these disadvantages has been to merely strengthen the joint by placing a reinforcing ring around the outside of the fold connection. However, this added reinforcing ring not only increases the manufacturing cost of the packing container, making it less saleable, but also increases the weight of the container considerably, thereby unfavorably influencing the shipping and freight charges of the containers and goods shipped in such containers.

It is therefore one of the primary objects of the present invention to provide means facilitating a rather inexpensive construction of a container which is very sturdy and well protected against breakage due to impact and rough handling.

It is another object of the present invention to provide means conducive to a very efficient packing and like container structure preventing leaks at the folded base or joint of the reinforced jacket defining such container.

It is a further object of the present invention to provide means offering the possibility of meeting the demands of the practice for strength and tightness of relative light-weight packing containers, even when filled with relatively heavy goods.

Yet a further object of the present invention is to provide means affording a low cost and highly efficacious container structure withstanding impact, shock and other stresses when applied in any and in particular radial direction to said container during shipping or transportation and storage.

Still another object of the present invention is to provide means rounding to an economical and extremely firm fold joint for a container which complies with all

2

practical requirements and is resistant to stress, breakage and distortions during use.

Still a further object of the present invention is to provide means retaining in position around a folded edge reinforcing lining or bottom wall extension portions for strengthening the container, even when the container is canted under force or struck on its edge.

It is a still further object of the present invention to provide means effectuating a strengthening of a folded joint of an upright wall of a container or envelope without inordinately increasing the thickness of the wall of said container.

These and other objects of the invention will become further apparent from the following detailed description, reference being made to the accompanying drawing, showing preferred embodiments of the invention.

In the drawings:

Fig. 1 is a perspective view, partly in section, of a portion of a fold connection constituting one embodiment of the invention;

Fig. 2 illustrates in perspective, partly in section, a portion of a fold connection according to another embodiment of the invention.

Fig. 3 illustrates in perspective view, partly in section, a portion of a fold connection forming still another embodiment of the present invention.

Referring now more particularly to the drawing, there is disclosed in Fig. 1 a jacket or outer wall 1 of a suitable container or receptacle for containing materials, merchandise and like goods.

The jacket or outer wall 1 is preferably composed of yieldable material such as paperboard, fiber, synthetic plastic material, rubber or like artificial compositions in order to permit the formation of a fold or overlap as shown at 3, without breakage or tearing of the material at its bend. Although a fold 3 completely turned over and forming a U-shaped end section of wall 1 is illustrated as a preferred embodiment, it is to be understood that fold 3 may also be of such configuration as to form any suitable angle relative to the remainder of wall 1 and when parallel may be folded back to be either substantially adjacent or spaced from wall 1. A sheet metal piece or extension 2 is employed to follow or conform to the outer contour of fold 3 and to enclose the lower end of wall 1 at 5, and terminates at the outer surface at wall 1 of location 6. A ring 4 of wire or other reinforcing material is inserted between legs 1a and 1b of the fold-over wall portions 1a, 1b and adjacent bend 3. Thus, the metal extension piece or liner 2 forms an outer reinforcing surface around the substantially U-shaped fold or bend, also provides an outer protection surface for the container fold at 5, and further forms a structural shape to resist bending of said fold.

The said extension 2 may terminate at 6 within the space formed between the legs 1a and 1b of the doubled-up end wall portion 1, 3. A reinforcing member 4 (Figs. 1 and 2) or 7 (Fig. 3) which may be in the form of an annulus, which is of round, square or of any other suitable cross-section, is inserted between legs 1a and 1b and is in contact with it least one of said legs, and located adjacent said reinforcing end portion 6.

Fig. 1 shows a round insert annulus or reinforcing member 4 in contact with both legs 1a, 1b and adjacent the end 6 of sheet metal liner or extension 2, 5, whereas according to Fig. 3 the insert annulus or reinforcing member 7 is located at the crotch 3a of the fold and is in direct contact with fold leg 1b and extends along substantially the entire height of fold leg 1b. In Fig. 2 the liner 2, 5 is conformed at 6a by a notch or bead to the cross-section of insert annulus or reinforcing member 4 to somewhat partially encircle the same, the outermost end 6b of said liner being located remote from said reinforcing member

4. According to Fig. 3, the annular reinforcing member 7 is made of steel, plastic or like mass, is rectangular in cross-section, is in contact with fold leg 1b and is co-extensive with the entire part 6 of the liner 2, 5 extending between the legs 1a and 1b.

As shown in the drawing, the part of liner forming the container base 2 is substantially level with the liner portion 2a on the upper end of the wall joint. Of course, the container base 2 and the liner portion 2a may lie in different planes, if desired.

As can be seen from the above disclosure the sheet or like protective or reinforcing means 2, 5, 6 may follow substantially the outer contour of the folded-over joint 3 of inner surface and outer surface of container wall 1 and may reach to a location within said joint, where separate annular insert or reinforcing member 4 or 7 cooperates with said protective means, is in frictional engagement therewith and offers greatest possible resistance against opening up of the reinforced will joint even under severe handling conditions of the container. Such insert member may also be employed in rolled-over fold connections.

The container is preferably made of a non-metallic, foldable material, such as pressboard, fiberboard, corrugated or other paper board, whereas the end or base walls (at top and bottom) are made from sheet metal or a material having sufficient rigidity and being ductile so as to be shaped around the folded-over edge of the container wall forming a jacket.

It should be noted that the length of the insert annulus or reinforcing ring 4 or 7 corresponds substantially to the outer perimeter or diameter of the jacket wall 1 of the container (not shown). The insert annulus 4 or 7 may be in the form of a wire or flat steel bar or any other suitable structural shape. Dimensions in cross section of the insert annulus or ring may be kept relatively small, thus avoiding any substantial increase in weight of the container.

Thus, the insert ring 4 or 7 serves to surround as well as to hold in place the sheet protective means 2, 5, 6 by frictional engagement. Therefore, any axial displacement of the end 6 of the sheet protective means will be prevented, since the sheet protective means is locked into position and must first slide past the annular insert 4 or 7, as the case may be.

The locking effect thus produced by the annular insert furthermore holds the base wall 2 of the container in desired position, and tends to prevent distortion thereof.

The reinforced joint of the present invention thus makes a container or receptacle particularly suitable for service under rigorous and severe handling conditions.

It can thus be seen that it has been provided according to the invention a non-metallic container having a metallic bottom wall and an upright wall of compressible material with a folded joint; said upright wall terminating in a U-shaped end section having one of the legs located at the outer surface of said upright wall, said bottom wall abutting against the inner surface of said upright wall and being likewise U-shaped so as to follow the outer contour of said U-shaped end section of the upright wall, and a re-

inforcing ring located between the legs of said U-shaped end section of said upright wall, said bottom wall including an extension portion integral therewith, said extension portion being directed over the end of said one leg of said end section and thence projecting between said legs thereof, said extension portion being at least partially conformed to the contour of said ring, thereby to deform said compressible material of said U-shaped end section of said upright wall at said ring and at said extension portion located between said legs of said U-shaped end section and adjacent said ring, so that a strong juncture between said U-shaped end section of said upright wall and said extension portion of said bottom wall and said ring is afforded.

Various changes and modifications may be made without departing from the spirit and scope of the present invention and it is intended that such obvious changes and modifications be embraced by the annexed claim.

Having thus described the invention, what is claimed as new and desired to be secured by Letters Patent, is:

In a joint for a container having an upright wall made of compressible material and a bottom wall made from sheet metal; said upright wall terminating in a U-shaped end section and having two legs, one of the legs being said upright wall and the other being located at the outer surface of said upright wall, said bottom wall abutting against the inner surface of said upright wall and being likewise U-shaped so as to follow the outer contour of said U-shaped end section of the upright wall, and a reinforcing ring of circular cross-section located between and deforming inwardly the adjacent portions of the legs of said U-shaped end section of said upright wall, said bottom wall including an extension portion integral therewith, said extension portion being directed over the end of said one leg of said end section and thence projecting between said legs thereof, said extension portion being curved to extend around one side of said ring and to at least partially conform to the contour of said ring, whereby deformation of said compressible material of said U-shaped end section of said upright wall at said ring and at said extension portion located between said legs of said U-shaped end section and adjacent said ring, effects a strong juncture between said U-shaped end section of said upright wall and said extension portion of said bottom wall and said ring is afforded.

References Cited in the file of this patent

UNITED STATES PATENTS

50	674,489	Wall	May 21, 1901
	1,669,691	Brandon	May 15, 1928
	1,998,312	Eggerss	Apr. 16, 1935
	2,031,887	Heifetz	Feb. 25, 1936
	2,343,550	Grove	Mar. 7, 1944
55	2,511,481	Schneider	June 13, 1950

FOREIGN PATENTS

	13,728	Denmark	Sept. 16, 1910
60	751,487	France	June 19, 1933