

No. 787,635.

PATENTED APR. 18, 1905.

A. PHINNEY.
HYDROCARBON BURNER.
APPLICATION FILED MAR. 24, 1904.

Fig. 1.

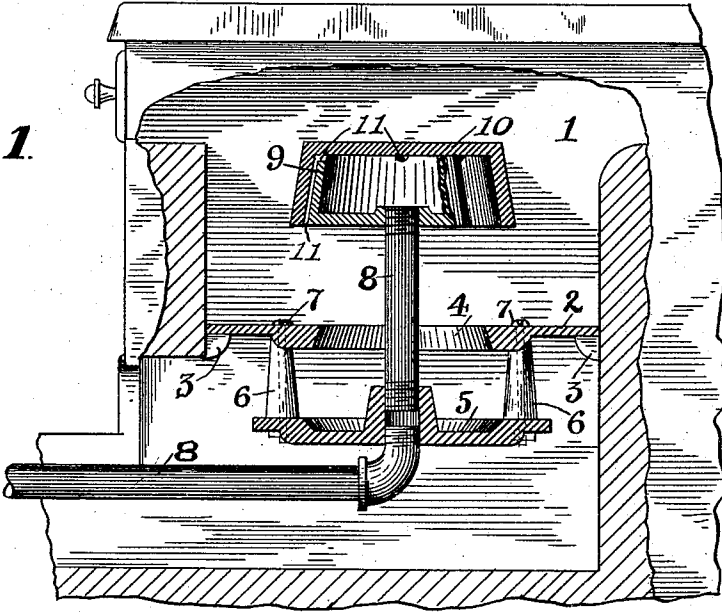
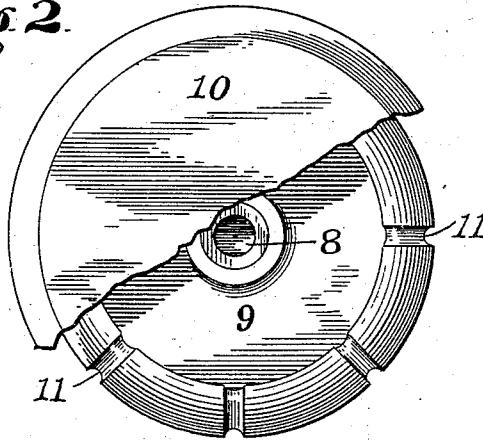

Fig. 2.



Witnesses.

Arthur F. Lee
Walter E. Lane

Inventor
Albert Phinney
by *N. A. Ackert*
att. in atty.

UNITED STATES PATENT OFFICE.

ALBERT PHINNEY, OF SAN FRANCISCO, CALIFORNIA.

HYDROCARBON-BURNER.

SPECIFICATION forming part of Letters Patent No. 787,635, dated April 18, 1905.

Application filed March 24, 1904. Serial No. 199,685.

To all whom it may concern:

Be it known that I, ALBERT PHINNEY, a citizen of the United States, residing in the city and county of San Francisco, State of California, have invented certain new and useful Improvements in Hydrocarbon-Burners; and I do hereby declare the following to be a full, clear, and exact description of the same.

My invention relates to that class of hydrocarbon-burners especially intended for use with the heavier liquid hydrocarbons, such as crude oil, and which are designed particularly for stoves and other like structures.

The object of my invention is to provide a simple and effective burner of that type in which an initial ignition of a small body of oil is adapted to furnish heat to a chamber within its sphere of influence in order to generate combustible vapor from a body of oil supplied to and maintained in said chamber, said burner being easily applied and readily removed for renewal or repairs.

To this end my invention consists in the novel hydrocarbon-burner which I shall hereinafter fully describe by reference to the accompanying drawings, in which—

Figure 1 is a cross-sectional view of my burner, showing it in place. Fig. 2 is a top view of the vaporizing-pan, the cover being broken.

1 is a fire-box in a stove or other like structure.

2 is a plate which forms the carrier for the burner. This plate is supported in the fire-box in any suitable manner. In practice it will rest upon the ledges 3 in the fire-box, taking the place of the usual grate, which is removed. In the supporting or carrier plate 2 is made an aperture 4, below which is a firing-pan 5, suspended from the plate in any suitable manner—as, for example, by the posts 6, secured to the plate by the screws 7.

8 is the oil-feed pipe, entering through the ash-pit opening and turning upwardly through the firing-pan 5, through the aperture 4 in plate 2, and projecting well up in the fire-box 1. In practice the feed-pipe is best made in the sections shown, screwed in the firing-pan, and supported thereby. Upon the top of

the feed-pipe within the fire-box is secured the vaporizing pan or chamber 9, into which the upper end of said feed-pipe opens, as shown. Over this vaporizing-pan is fitted the cover 10. The upper edge or rim of the vaporizing-pan is formed with grooves 11, which provide exit-spaces for the vapor between the pan and cover. I have found that a comparatively close fit of the cover and pan is the better practice, as even by the ordinary inaccuracies of the metal an exit-space is left which will permit the escape of the vapor under some pressure, which is beneficial in forming the combustible mixture with the air; but to prevent any tendency of the cover to seat itself vapor-tight on the pan I deem it best to make the grooves 11 in the upper rim of the pan, said grooves being in practice quite small, the illustration being an exaggeration for the sake of clearness. If desired the grooves 11 may be carried down the outer surface of the pan, as I have shown, through these distinct spaces are not at all necessary, for the vapor will escape properly between the cover and pan without them.

The operation of the burner is as follows: The oil is supplied through pipe 8 until it fills and overflows the vaporizing-pan 9, the overflow falling and trickling down through the plate-aperture 4 into the firing-pan 5. When a sufficient quantity is in the pan 5, the supply of oil is temporarily cut off and the oil in said pan is ignited. The flames from the burning oil rising through aperture 4 heat up the vaporizing-pan above. When the temperature is high enough, vapor is generated in pan 9, and said vapor escaping from under the cover through such exits as may naturally exist between them or through the prepared exits, such as the grooves 11, ignites at the base of the pan and cover, and the flames spread through the fire-box. Then the supply of oil is resumed and the required quantity maintained in the vaporizing-pan.

The entire burner can be readily placed in and removed from the fire-box.

Having thus described my invention, what I claim as new, and desire to secure by Letters Patent, is—

A hydrocarbon-burner comprising a carry-

ing-plate having an aperture, a feed-pipe
passing upwardly through said aperture, a
vaporizing-pan carried upon and communi-
cating with the upper end of the feed-pipe,
5 and adapted to receive the oil therefrom, a
firing-pan secured to said feed-pipe and to
the carrying-plate below the aperture there-
in, and adapted to receive the initial overflow
10 from the vaporizing-pan, a cover closely fit-
ted to the vaporizing-pan having a depend-

ing flange extending to approximately the
lower edge of the pan, the walls of the pan
being grooved beneath the cover to provide
exits for the vapor.

In witness whereof I have hereunto set my
hand.

ALBERT PHINNEY.

Witnesses:

N. A. ACKER,
D. B. RICHARDS.