

Nov. 17, 1953

C. A. HUGHES

2,659,415

RECLINING CHAIR WITH COORDINATED LEG REST

Filed Jan. 12, 1953

3 Sheets-Sheet 1

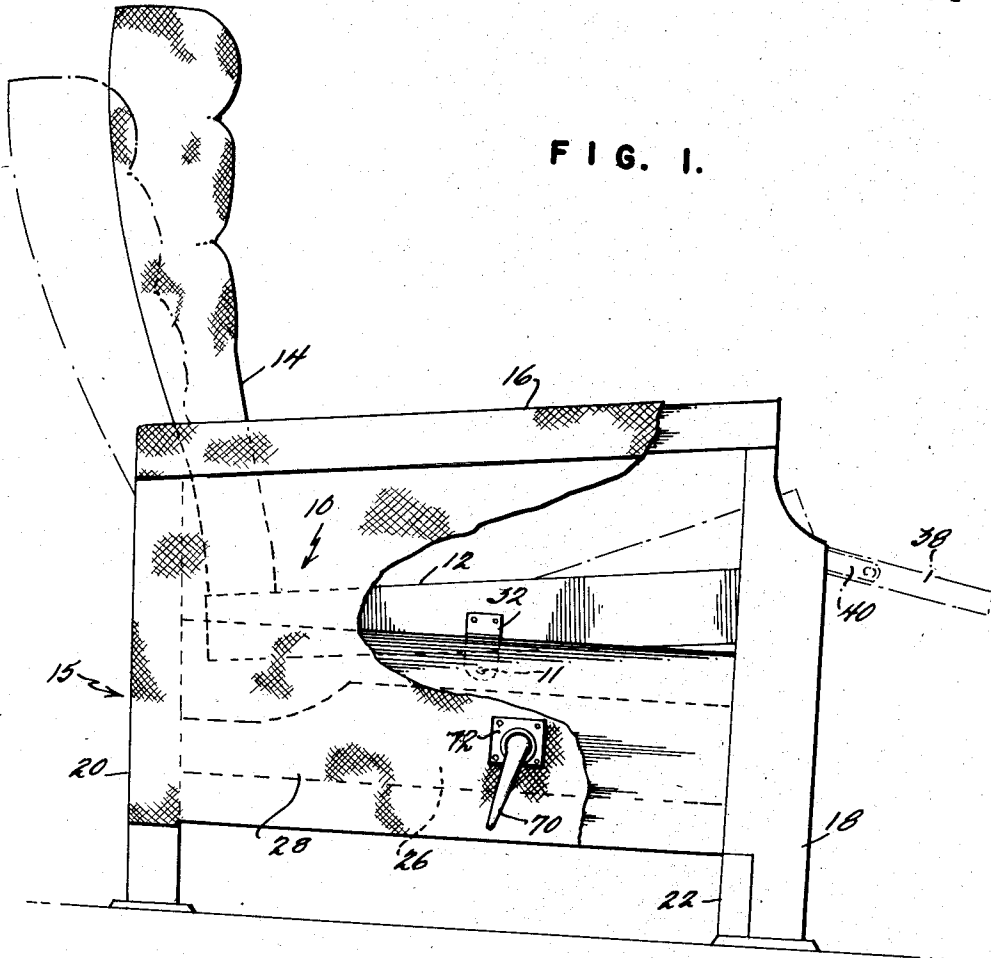

FIG. 1.

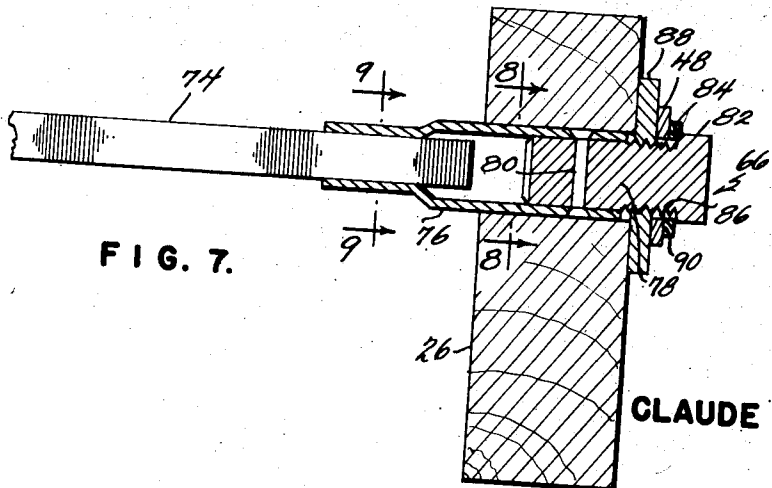

FIG. 7.

FIG. 8.

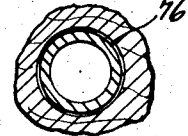
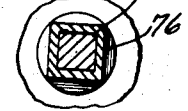

FIG. 9.



INVENTOR
CLAUDE A. HUGHES

BY *Jawett, Mead Brown, and
Schuyler*
ATTORNEYS

Nov. 17, 1953

C. A. HUGHES

2,659,415

RECLINING CHAIR WITH COORDINATED LEG REST

Filed Jan. 12, 1953

3 Sheets-Sheet 2

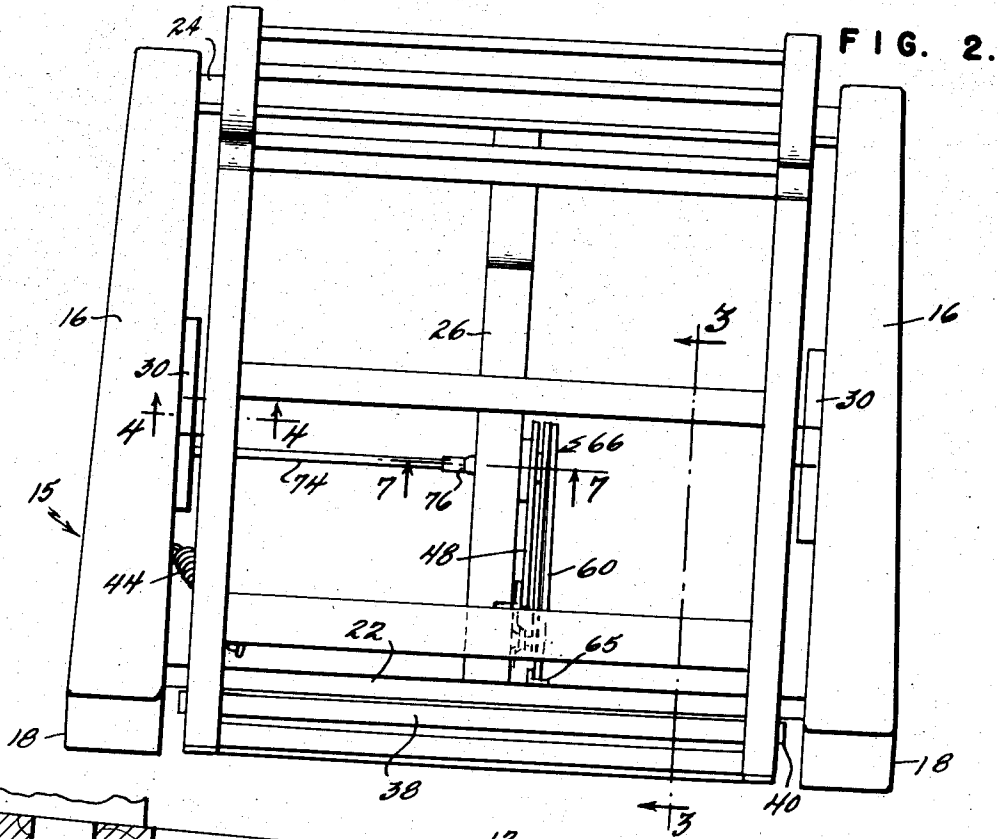

FIG. 2.

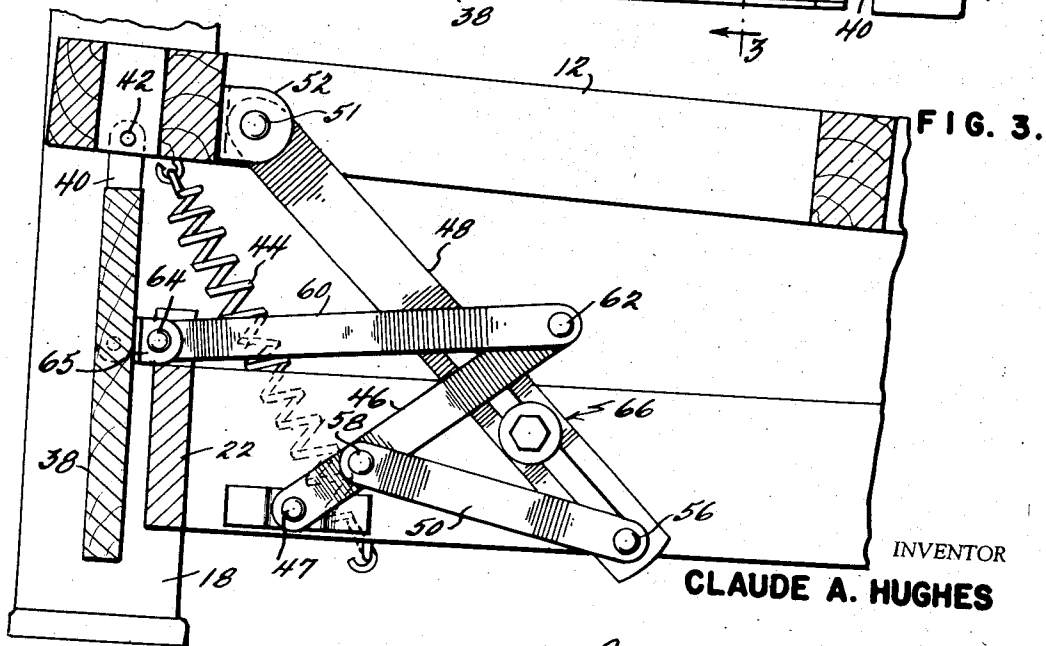

FIG. 3.

INVENTOR

CLAUDE A. HUGHES

BY *Jawett, Mead, Browne
and Schuyler*
ATTORNEYS

Nov. 17, 1953

C. A. HUGHES

2,659,415

RECLINING CHAIR WITH COORDINATED LEG REST

Filed Jan. 12, 1953

3 Sheets-Sheet 3

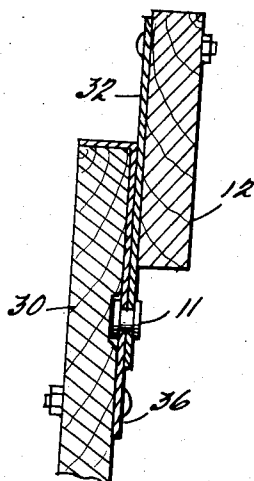

FIG. 4.

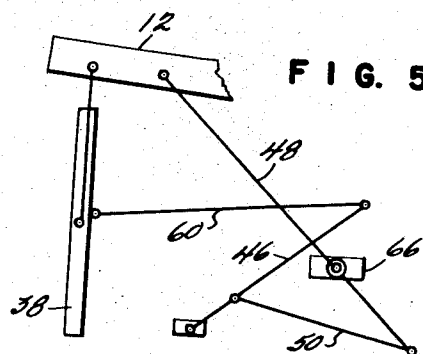

FIG. 5.

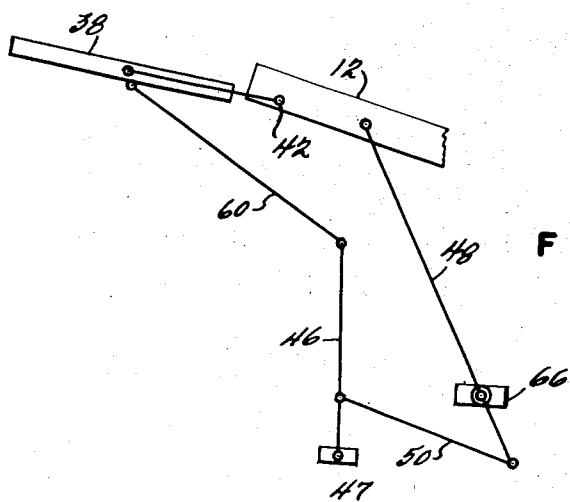

FIG. 6.

INVENTOR
CLAUDE A. HUGHES

BY *Jewett, Mead, Browne
and Schuyler*
ATTORNEYS

UNITED STATES PATENT OFFICE

2,659,415

RECLINING CHAIR WITH COORDINATED LEG REST

Claude A. Hughes, High Point, N. C.

Application January 12, 1953, Serial No. 330,698

11 Claims. (Cl. 155-105)

1

This invention relates to reclining chairs and more particularly to reclining chairs of the type having a leg rest member which moves in coordination with the movements of the seat and back of the chair.

During recent years, reclining chairs of the type in which the seat member or back member or both may be pivotally swung about a horizontal axis into a reclining position have become quite popular. A desirable feature in connection with such a chair is the provision of a leg rest member which is normally maintained in an inoperative position when the movable chair seat or back is in a normal sitting position, but which may be swung upwardly to serve its leg rest function in coordination with movements of the chair members into reclining position. It is desirable that the linkage system coordinating movements of the seat, back and leg rest in such a chair be simple in structure and easily operated. It is also necessary to provide a locking arrangement which permits locking of the pivotally mounted seat or back and the attached leg rest in any desired position.

Accordingly, it is an object of this invention to provide a reclining chair in which movements of the seat or back are communicated to a leg rest member.

It is a further object of this invention to provide an improved arrangement for communicating motions of a pivotally mounted seat or back to a leg rest member which is pivotally connected to the front portion of the chair.

It is a still further object of this invention to provide a linkage system between a pivoted seat or back and a leg rest member which is simple to manufacture and which is easily operable.

It is another object of this invention to provide a locking arrangement which cooperates with the linkage interconnecting the seat or back and leg rest to lock the reclining chair in any desired angular position.

In accordance with these objectives, this invention provides a reclining chair having a seat-back structure which is pivotally connected to a supporting structure, and a leg rest member pivotally connected to the front portion of the seat, with a linkage system connected between the seat-back structure and the leg rest to communicate motions of the seat-back to the leg rest. This linkage system comprises a lever member which is pivotally connected to the supporting structure of the chair, a connecting member which is pivotally connected at one of its ends to the movable seat or back and at the other

2

of its ends to a link which connects it to an intermediate portion of the lever member, and a link connecting the leg rest member to an outer portion of the lever member. An important feature of my invention is the provision of a locking means which cooperates with the connecting member to permit locking of the seat-back structure and the pivotally connected leg rest in any desired position.

The features of this invention which I believe to be novel are set forth with particularity in the appended claims. My invention itself, however, both as to its organization and use, together with further objects and advantages thereof, may be best understood by reference to the following description, taken in connection with the accompanying drawings in which

Fig. 1 is a side elevation, partially cut away, of a reclining chair in accordance with my invention;

Fig. 2 is a plan view of the chair of Fig. 1; Fig. 3 is an enlarged fragmentary view taken along vertical section line 3-3 of Fig. 2;

Fig. 4 is an enlarged fragmentary view taken along vertical section line 4-4 of Fig. 2;

Fig. 5 is a graphical representation of the linkage system between the pivoted seat and the pivoted leg rest when the chair is in normal sitting position;

Fig. 6 is a graphical representation of the position of the linkage system interconnecting the seat and the leg rest when the chair is in reclining position;

Fig. 7 is an enlarged view of the locking mechanism taken along section line 7-7 of Fig. 2;

Fig. 8 is a view of a portion of the locking arrangement taken along section line 8-8 of Fig. 7; and

Fig. 9 is a view of a portion of the locking arrangement taken along section line 9-9 of Fig. 7.

Referring now to the drawings, and more particularly to Figs. 1 and 2, I have illustrated my invention as embodied in a reclining chair having a movable unitary seat-back structure, generally indicated at 10, comprising a seat frame portion 12 which is rigidly connected to a back frame portion 14. The seat-back structure 10 is supported for movement about a horizontal axis on pivots 11 by a stationary supporting framework generally indicated at 15. The chair is provided with a pair of oppositely disposed arm members 16 which are supported by front vertically-extending frame members or legs 18 and rear vertically-extending frame members or legs

3
 20 on either side of the chair. Legs 18 are joined at their lower end at the front portion of the chair by a cross piece member 22 and legs 20 at the rear of the chair are joined at their lower end by a cross piece member 24. A brace member 26 is positioned intermediate of the width of the chair at the bottom thereof and extends from the cross piece member 24 at the rear of the chair to cross piece member 22 at the front of the chair. A rigid side wall portion 28 extends for at least part of the height of the chair between the front leg 18 and the rear leg 20 on each side of the chair.

It will be seen, therefore, that the stationary or supporting framework of the chair comprises arms 16, legs 18 and 20, frame members 22, 24, 26, and the side wall portions 28.

The unitary seat-back structure is pivotally mounted for movement about a horizontal axis by means of a pivotal connection 11 intermediate of the length of the seat portion. As a support for the pivotal connection, a support member 30 may be rigidly attached to the inner surface of wall portion 28 on each of the opposite sides of the chair, substantially centrally located with respect to the length of the chair. A metal bracket member 32, best shown in Fig. 4, is rigidly attached to the side edge of the seat frame 12, bracket member 32 extending below the bottom surface of the seat frame. A suitable pivot pin 11 passes through the lower portion of the bracket 32 and through a bracket member 36 which is rigidly fixed to the support member 30. A similar pivotal connection is provided on each of the opposite sides of the chair, and due to these pivotal connections the unitary seat-back structure 10 may be pivoted with respect to the stationary frame structure about the pivot pins 11. I have shown the arrangement just described as an operative embodiment of my structure but obviously other pivotal connections between the unitary seat-back and the support could be provided.

A leg rest 38 is pivotally connected to the seat at the front portion thereof by any suitable means, such as metal bands 40 which are rigidly connected to the side edges of the leg rest and which are pivotally connected to the side edges of the seat frame 12 at 42. A spring member 44 which normally biases the chair in the sitting position is connected between the under portion of the seat 12 adjacent the front thereof and the inner surface of wall 28 at one side of the chair.

In order to communicate to the leg rest member 38 motion of the seat-back structure about its pivotal connection with respect to the supporting framework of the chair, a linkage system is used which will now be described. The linkage system connecting the seat and the leg rest comprises a lever member 46 which is pivotally connected at point 47 to the intermediate cross piece member 26 which extends from the front to the rear of the chair. A connecting member 48 is pivotally attached at 51 to a bracket member 52 which is rigidly connected to the seat structure. The opposite end of connecting member 48 is pivotally connected at 56 to a link 50 which, in turn, is pivotally connected at 58 to an intermediate portion of lever 46. A link 60 communicates motions of lever 46 to leg rest 38, link 60 being pivotally connected at 62 to the outer end of lever 46 and at 64 to a bracket member 65 which is rigidly attached to leg rest 38.

An important feature of my invention is the

manner in which connecting member 48 cooperates with a locking means to permit locking of the movable chair members in any desired angular position. In the embodiment shown in the drawings, connecting member 48 is slotted along a portion of its length to permit passage through the member of a locking means generally indicated at 66 which will be described hereinafter in more detail. The locking mechanism may be operated to lock the linkage in any given position but when the locking mechanism is released, as will be later described, the connecting member 48 is movable in a path which is constrained by the presence of the locking member.

There are diagrammatically illustrated in Figs. 5 and 6, respectively, the positions of the seat member 12, the leg rest 38, and the interconnecting linkage between these members in both the normal sitting position of the chair and the reclining position of the chair. The diagrammatic representation of Fig. 5 corresponds to the position of the linkage as shown in Fig. 3. When the seat 12 is moved in a clockwise direction with respect to the views shown in Figs. 5 and 6, about its pivotal connection 11 to the stationary framework of the chair, and assuming that the locking mechanism has been released, connecting member 48 moves upwardly along its slotted portion, at the same time moving in a clockwise direction. The clockwise motion of member 48 is communicated by link 50 to lever 46, which is caused to pivot in a counterclockwise direction about its pivot point 47. The counterclockwise motion of lever 46 causes link member 60 which is connected between the upper end of lever member 46 and the leg rest member 38, to be moved to the left with respect to the views shown in Figs. 5 and 6, causing leg rest member 38 to be pivoted upwardly in a clockwise direction about its pivotal connection 42 to the seat 12. The motion of the seat-back structure is multiplied or amplified in being transmitted to the leg rest due to the fact that the leg rest is connected to the outer portion of lever 46, whereas the link 50, attached to connecting member 48, is attached to the intermediate portion of lever 46.

In order to lock the unitary seat-back and connected leg rest in any desired angular position, I have provided in cooperative relation with connecting member 48 a locking mechanism which in general is similar to that disclosed in my pending application Serial No. 293,993, filed June 17, 1952. The locking mechanism is operated by a handle member 70 which passes through a mounting plate 72 which is rigidly attached to the outside surface of one of the side walls 28 of the chair. An operating shaft 74 which is square in cross-section is rigidly attached to handle 70 and passes through a suitable aperture provided in the side wall 28. The opposite end of shaft 74 fits into one end of a hollow shaft 76 which passes through a suitable aperture in cross piece or brace member 26. The end of the hollow shaft 76 which receives square shaft 74 is square in cross-section, but the opposite end of hollow shaft 76 is round in cross-section to receive a rod member 78 of round cross-section which is held in a fixed position with respect to hollow shaft 76 by a pin member 80. Rod member 78 is provided with a portion which projects outwardly from the end of hollow shaft 76, the outermost end of this outwardly projecting portion being provided with a head member 82, head 82 having shoulders 84 which provide a bearing surface. Starting at the shoulders 84 and extending for a portion of the

length of rod 78 are external threads 86 which co-act with the internal threads of a bearing member 88 which is rigidly attached to the side of support member 26. The slotted portion of connecting member 43 is interposed between the surface of bearing member 88 and the shoulders 84 of head member 82. A metal washer 90 may be interposed between shoulders 84 and the surface of link 48.

When handle member 70 is turned to operate shaft 74, the rotation of shaft 74 is communicated to hollow shaft 76, causing shaft 76 and rod member 78 to turn. The threads 86 on rod member 78 cooperate with the threads on bearing member 88 and cause an axial shifting of hollow shaft 76, rod member 78 and head 82 in such manner as to either clamp or unclamp the bearing shoulders 84 of head 82 with respect to member 48. Thus, by turning the handle 70 in one direction, the operator may tighten the head 82 against the washer 90 and member 48 in such manner as to clamp the linkage system in fixed position. When the handle member is turned in the other direction, the head 82 is unclamped with respect to member 48, and the chair may be adjusted to any desired angular position, after which the locking mechanism is again tightened to clamp the members in position. Due to the fact that operating shaft 74 is not positively connected to the hollow shaft 76, shaft 76 may have an axial motion with respect to shaft 74 without causing any axial movement of shaft 74 or handle 70.

It can be seen from the foregoing that I have provided in accordance with my invention an improved arrangement for reclining chairs having coordinated leg rests. I have provided a linkage for communicating movements of a pivoted seat or back member to a leg rest which is simple in construction and economical to manufacture, and which is characterized by ease and sureness of operation. Furthermore, I have provided an arrangement for locking the movable chair elements in any desired angular position in accordance with which a locking means cooperates with the connecting member which communicates motion of the movable seat or back to the leg rest linkage.

While I have shown and described my linkage arrangement for coordinating motion of the leg rest and for locking the chair elements in position in connection with a reclining chair having a unitary seat-back structure, obviously my linkage and locking arrangement could be used in connection with a chair in which the seat and back are movable relative to each other.

While there has been shown and described a particular embodiment of my invention, it will be obvious to those skilled in the art that various changes and modifications can be made therein without departing from the invention and, therefore, it is aimed in the appended claims to cover all such changes and modifications as fall within the true spirit and scope of the invention.

Having thus described the invention, what is claimed as new and desired to secure by Letters Patent is:

1. A reclining chair comprising a supporting framework, a chair body member pivotally supported by said framework for movement about a horizontal axis, a leg rest member pivotally supported at the front of said chair, a connecting member pivotally attached to said body member, a lever member pivotally connected to said framework, a first link means joining said connecting member to said lever member, and a second link

means joining said lever member to said leg rest.

2. A reclining chair as defined in claim 1 in which said second link means is connected to an outer portion of said lever member and said first link means is connected to said lever at a point intermediate the pivotal connection of said lever to said framework and the point of connection of said second link means.

3. A reclining chair as defined in claim 1 having locking means engageable with said connecting member to lock said chair body member in position.

4. A reclining chair as defined in claim 1 in which said connecting member is slotted to receive a locking means.

5. A reclining chair as defined in claim 1 comprising means for locking said chair body member in a predetermined angular position, said locking means comprising a bearing member rigidly attached to said supporting framework, said bearing member being internally threaded, a rod member supported for rotation in said bearing member, said rod member being externally threaded to mate with the internal threads of said bearing, handle means for turning said rod member, a locking head rigidly attached to an end of said rod member, said connecting member being slotted longitudinally to receive said rod member, said locking head being disposed adjacent a surface of said connecting member for locking engagement therewith.

6. A reclining chair comprising a supporting framework, a chair body member pivotally supported by said framework for movement about a horizontal axis, a leg rest member pivotally supported at the front of said chair, a connecting member pivotally connected to said body member, a lever member pivotally connected to said framework, a link joining said connecting member to said lever member and a link joining said lever member to said leg rest.

7. A reclining chair comprising a supporting framework, a seat member pivotally connected to said framework for movement about a horizontal axis, a leg rest member pivotally connected to the front portion of said seat member, and means for coordinating movement of said leg rest with movement of said seat about said pivotal connection of said seat, said means comprising a lever member pivotally mounted on said supporting framework, a connecting member pivotally attached to said seat, link means joining said connecting member to said lever member, and link means connected between an outer portion of said lever member and said leg rest.

8. A reclining chair as defined in claim 7 having locking means engageable with said connecting member to lock said seat member in position.

9. A reclining chair as defined in claim 7 comprising means for locking said seat member in a predetermined angular position, said connecting member being longitudinally slotted to receive said locking means.

10. A reclining chair as defined in claim 7 comprising means for locking said seat member in a predetermined angular position, said locking means comprising a bearing member rigidly attached to said supporting framework, said bearing member being internally threaded, a rod member supported for rotation in said bearing member, said rod member being externally threaded to mate with the internal threads of said bearing, handle means for turning said rod

7

member, a locking head rigidly attached to an end of said rod member, said connecting member being slotted longitudinally to receive said rod member, said locking head being disposed adjacent a surface of said connecting member for locking engagement therewith.

11. A reclining chair comprising a unitary seat-back member, a stationary supporting framework for said seat-back member, said seat-back member being pivotally connected to said framework for movement about a horizontal axis, a leg rest member, said leg rest member being pivotally connected to the seat portion of said seat-back member at the front portion thereof, and means for coordinating the movement of said leg rest with said seat-back member com-

8

prising a lever member pivotally connected to said supporting framework, a connecting member pivotally connected at one of its ends to said seat, a link joining the other end of said connecting member to an intermediate point of said lever member, and a link connected between an outer portion of said lever and said leg rest.

CLAUDE A. HUGHES.

References Cited in the file of this patent

UNITED STATES PATENTS

Number	Name	Date
2,470,781	Lorenz -----	May 24, 1949
2,647,559	Richardson -----	Aug. 4, 1953