



INTERNATIONAL APPLICATION PUBLISHED UNDER THE PATENT COOPERATION TREATY (PCT)

<p>(51) International Patent Classification ⁷ : B21D 7/03</p>	<p>A1</p>	<p>(11) International Publication Number: WO 00/41825 (43) International Publication Date: 20 July 2000 (20.07.00)</p>
<p>(21) International Application Number: PCT/EP00/00208 (22) International Filing Date: 13 January 2000 (13.01.00) (30) Priority Data: TO99A000034 18 January 1999 (18.01.99) IT (71) Applicant (for all designated States except US): E.M.A.R.C. S.p.A. [IT/IT]; Viale Piemonte, 0/9, I-10048 Vinovo (IT). (72) Inventor; and (75) Inventor/Applicant (for US only): PASSONE, Pietro [IT/IT]; Viale Buoizzi, 7, I-10048 Vinovo (IT). (74) Agents: GERBINO, Angelo et al.; Jacobacci & Perani S.p.A., Corso Regio Parco, 27, I-10152 Torino (IT).</p>		<p>(81) Designated States: AE, AL, AM, AT, AU, AZ, BA, BB, BG, BR, BY, CA, CH, CN, CR, CU, CZ, DE, DK, DM, EE, ES, FI, GB, GD, GE, GH, GM, HR, HU, ID, IL, IN, IS, JP, KE, KG, KP, KR, KZ, LC, LK, LR, LS, LT, LU, LV, MA, MD, MG, MK, MN, MW, MX, NO, NZ, PL, PT, RO, RU, SD, SE, SG, SI, SK, SL, TJ, TM, TR, TT, TZ, UA, UG, US, UZ, VN, YU, ZA, ZW, ARIPO patent (GH, GM, KE, LS, MW, SD, SL, SZ, TZ, UG, ZW), Eurasian patent (AM, AZ, BY, KG, KZ, MD, RU, TJ, TM), European patent (AT, BE, CH, CY, DE, DK, ES, FI, FR, GB, GR, IE, IT, LU, MC, NL, PT, SE), OAPI patent (BF, BJ, CF, CG, CI, CM, GA, GN, GW, ML, MR, NE, SN, TD, TG).</p> <p>Published With international search report.</p>

(54) Title: A PROCEDURE FOR BENDING A PROFILED METAL ELEMENT WHILE LIMITING DEFORMATION OF ITS CROSS-SECTIONAL SHAPE

(57) Abstract

The bending procedure calls for a restraining force to be exerted on the profiled metal element (10) in a direction substantially orthogonal to that of the forces causing the bend, at the same time as the said forces are being exerted, in order to limit any deformation of the cross-sectional shape of the element (10). The associated apparatus includes means for exerting on the element (10) a restraining force in a direction substantially orthogonal to that of the forces causing the bending.

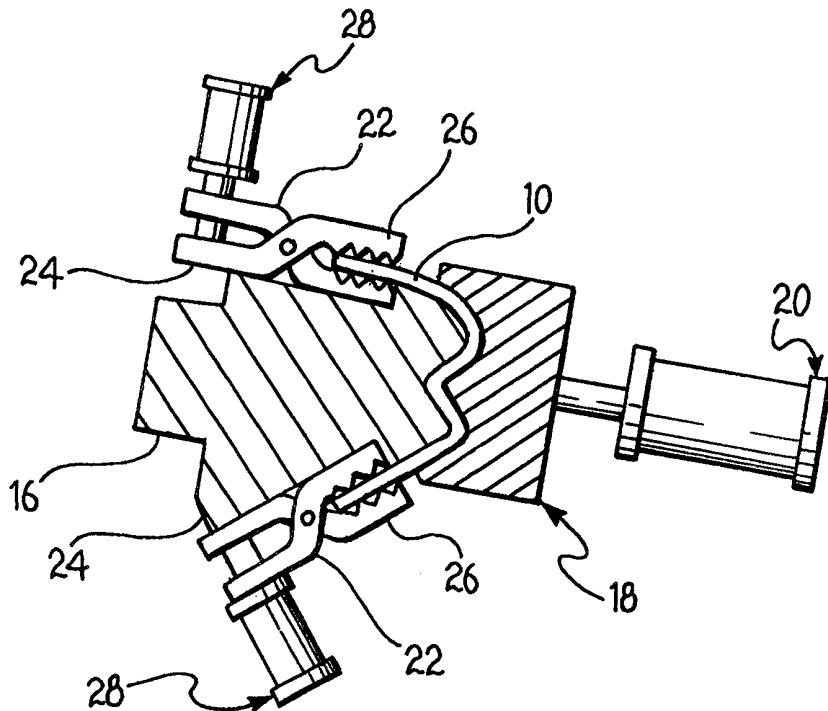

FOR THE PURPOSES OF INFORMATION ONLY

Codes used to identify States party to the PCT on the front pages of pamphlets publishing international applications under the PCT.

AL	Albania	ES	Spain	LS	Lesotho	SI	Slovenia
AM	Armenia	FI	Finland	LT	Lithuania	SK	Slovakia
AT	Austria	FR	France	LU	Luxembourg	SN	Senegal
AU	Australia	GA	Gabon	LV	Latvia	SZ	Swaziland
AZ	Azerbaijan	GB	United Kingdom	MC	Monaco	TD	Chad
BA	Bosnia and Herzegovina	GE	Georgia	MD	Republic of Moldova	TG	Togo
BB	Barbados	GH	Ghana	MG	Madagascar	TJ	Tajikistan
BE	Belgium	GN	Guinea	MK	The former Yugoslav Republic of Macedonia	TM	Turkmenistan
BF	Burkina Faso	GR	Greece	ML	Mali	TR	Turkey
BG	Bulgaria	HU	Hungary	MN	Mongolia	TT	Trinidad and Tobago
BJ	Benin	IE	Ireland	MR	Mauritania	UA	Ukraine
BR	Brazil	IL	Israel	MW	Malawi	UG	Uganda
BY	Belarus	IS	Iceland	MX	Mexico	US	United States of America
CA	Canada	IT	Italy	NE	Niger	UZ	Uzbekistan
CF	Central African Republic	JP	Japan	NL	Netherlands	VN	Viet Nam
CG	Congo	KE	Kenya	NO	Norway	YU	Yugoslavia
CH	Switzerland	KG	Kyrgyzstan	NZ	New Zealand	ZW	Zimbabwe
CI	Côte d'Ivoire	KP	Democratic People's Republic of Korea	PL	Poland		
CM	Cameroon	KR	Republic of Korea	PT	Portugal		
CN	China	KZ	Kazakstan	RO	Romania		
CU	Cuba	LC	Saint Lucia	RU	Russian Federation		
CZ	Czech Republic	LI	Liechtenstein	SD	Sudan		
DE	Germany	LK	Sri Lanka	SE	Sweden		
DK	Denmark	LR	Liberia	SG	Singapore		
EE	Estonia						

A PROCEDURE FOR BENDING A PROFILED METAL ELEMENT WHILE LIMITING DEFORMATION OF ITS CROSS-SECTIONAL SHAPE

The present invention relates to a procedure for bending a profiled metal element in one or more dimensions and associated apparatus.

The object of the invention is to provide a procedure of the above type whereby bending a profiled metal element, notably by drawing, does not carry the side effect of deforming the cross-sectional shape thereof.

This object is achieved thanks to a bending procedure characterised in that it exerts a restraining force on the said profiled metal element in a direction substantially orthogonal to that of the forces causing the bend, at the time that they are acting.

This restraining force counters the tendency of the cross section of the element to become deformed, thus ensuring that it retains its original shape.

Profile elements of an open or partially closed type are suited to the procedure of the invention.

A further object of the invention comprises apparatus for carrying out the aforesaid procedure, including means for exerting on the element to be bent a restraining force in a

direction substantially orthogonal to that of the forces causing the bend.

Additional advantages and characteristics of the present invention will become clear from the detailed description which follows, with reference to the appended drawings, provided purely by way of non-limitative example, in which:

Figure 1 is a perspective view of a profiled metal element to be bent by the procedure of the invention, and

Figure 2 is a view in section, taken on the line II-II of Figure 1, of the profiled element arranged on apparatus operable to carry out the procedure of the invention.

An elongate profiled metal element 10, having a W-shape in cross section (see Figure 1) is to be bent in several dimensions as shown by the arrows 14.

In order to carry out this bending procedure, apparatus is used which is known per se in the art and is only schematically illustrated in figure 2, and includes a template 16 having the shape to be imparted to the metal element and a series of dies 18 operated by respective actuators 20 able to press the element 10 against the template 16.

The surfaces of the template 16 and of the dies 18 intended to come into contact with the element 10 match the shape of the latter in order to provide adequate support during the bending procedure.

The apparatus also includes means for exerting a restraining force on the element 10 in a direction substantially orthogonal to that of the forces causing the bend by drawing.

These restraining means comprise pincers 22 located in recesses 24 formed along both sides of the template 16 and having jaws 26 able to grip the transverse edge regions of the element 10.

The jaws 26 of the pincers 22 are operated by respective actuators 28, which may be mechanically, pneumatically, hydraulically or electrically operated.

In embodiments of the invention, not illustrated, the pincers can be replaced by vices, operated by mechanical lever systems instead of actuators.

In order to carry out the bending procedure, the jaws 26 of the pincers 22 hold the edge regions of the element 10 against the template 16 so that the forces exerted by the dies 18 produce the required bend by drawing the element 10 without deforming its cross-sectional shape.

In dependence on the shape of the element 10 and on the bending forces exerted on it, it is possible to provide a specific number of pincers 22 and/or a particular layout thereof, such that the cross section of the profiled element remains unchanged during the entire procedure.

Naturally, the principle of the invention remaining the same, manufacturing details and embodiments may vary widely from

those described and illustrated here purely by way of non-limitative example, without departing thereby from the scope of the invention.

For example, the bending of the profiled element can take place also only in one dimension, the longitudinal axis of the element remaining in the plane wherein it was originally.

CLAIMS

1. A procedure for bending a profiled metal element (10) in one or more dimensions, characterised in that it provides for a restraining force to be exerted on the said element (10) in a direction substantially orthogonal to that of the forces causing the bend and at the same time as the bending forces are acting, in order to limit any deformation of the cross-sectional shape of the element (10).
2. Apparatus for bending a profiled metal element (10) in one or more dimensions, characterised in that it includes means for exerting a restraining force on the said element (10) along a direction substantially orthogonal to that of the forces determining the bend.
3. Apparatus according to the preceding claim, characterised in that the said restraining means are mechanically, pneumatically, hydraulically or electrically operated.
4. Apparatus according to Claim 2 or Claim 3, characterised in that the said restraining means comprise pincers (22) and/or vices, located along both sides of the element (10) and having jaws (26) able to grip the transverse edge regions of the element (10).

FIG. 1

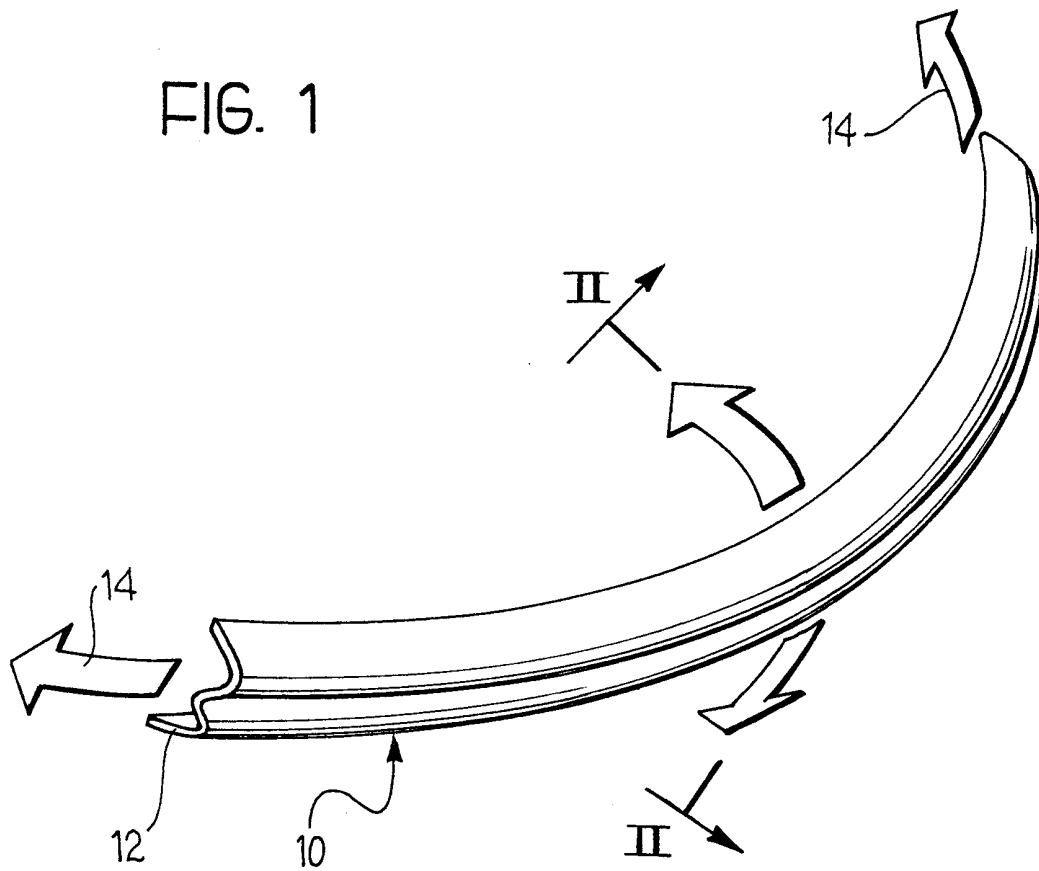
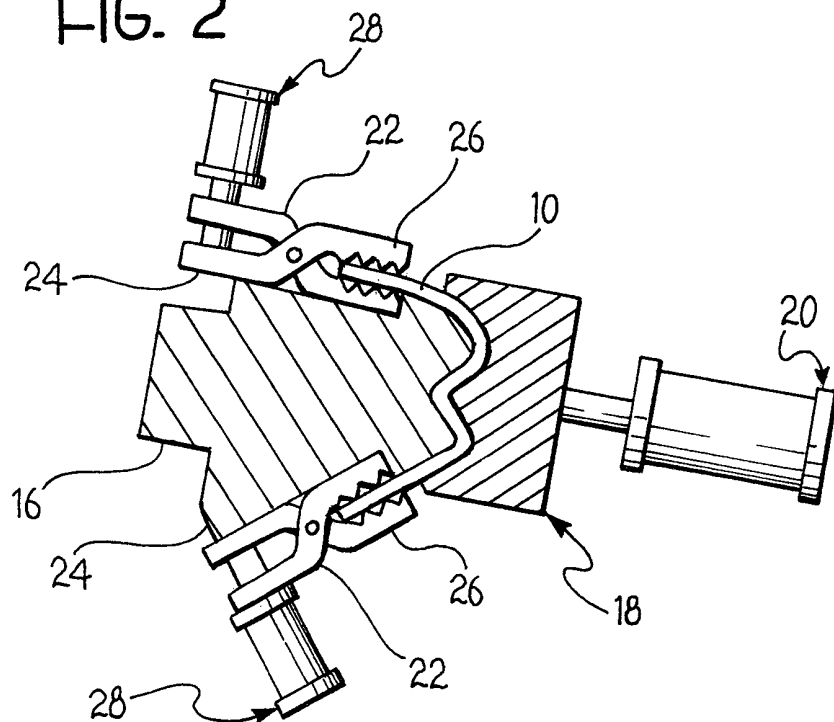

FIG. 2



INTERNATIONAL SEARCH REPORT

International Application No

PCT/EP 00/00208

A. CLASSIFICATION OF SUBJECT MATTER

IPC 7 B21D7/03

According to International Patent Classification (IPC) or to both national classification and IPC

B. FIELDS SEARCHED

Minimum documentation searched (classification system followed by classification symbols)

IPC 7 B21D

Documentation searched other than minimum documentation to the extent that such documents are included in the fields searched

Electronic data base consulted during the international search (name of data base and, where practical, search terms used)

C. DOCUMENTS CONSIDERED TO BE RELEVANT

Category *	Citation of document, with indication, where appropriate, of the relevant passages	Relevant to claim No.
X	US 1 721 964 A (MCALEENAN) 23 July 1929 (1929-07-23) page 1, line 60-65; figures 1-8 -----	1-5
X	DE 15 27 336 A (HAMBURGER FLUGZEUGBAU GMBH) 24 April 1969 (1969-04-24) page 4; figures 1,2,5,20 -----	1-5
X	US 3 898 832 A (ECKOLD) 12 August 1975 (1975-08-12) figures 1-4,7,8 -----	1-5
X	GB 982 694 A (REYNOLDS METAL COMPANY) page 8, line 31-77; figure 43 -----	1,2,5

Further documents are listed in the continuation of box C.

Patent family members are listed in annex.

* Special categories of cited documents :

- *A* document defining the general state of the art which is not considered to be of particular relevance
- *E* earlier document but published on or after the international filing date
- *L* document which may throw doubts on priority claim(s) or which is cited to establish the publication date of another citation or other special reason (as specified)
- *O* document referring to an oral disclosure, use, exhibition or other means
- *P* document published prior to the international filing date but later than the priority date claimed

- *T* later document published after the international filing date or priority date and not in conflict with the application but cited to understand the principle or theory underlying the invention
- *X* document of particular relevance; the claimed invention cannot be considered novel or cannot be considered to involve an inventive step when the document is taken alone
- *Y* document of particular relevance; the claimed invention cannot be considered to involve an inventive step when the document is combined with one or more other such documents, such combination being obvious to a person skilled in the art.
- *Z* document member of the same patent family

Date of the actual completion of the international search

19 April 2000

Date of mailing of the international search report

03/05/2000

Name and mailing address of the ISA

European Patent Office, P.B. 5818 Patentlaan 2
NL - 2280 HV Rijswijk
Tel. (+31-70) 340-2040, Tx. 31 651 epo nl,
Fax: (+31-70) 340-3016

Authorized officer

Ash, R

INTERNATIONAL SEARCH REPORT

Information on patent family members

Inter. Application No PCT/EP 00/00208
--

Patent document cited in search report	A	Publication date	Patent family member(s)	Publication date
US 1721964	A	23-07-1929	NONE	
DE 1527336	A	24-04-1969	NONE	
US 3898832	A	12-08-1975	DE 2345138 A	27-03-1975
			DE 2356451 A	22-05-1975
			AT 334160 B	10-01-1976
			AT 615274 A	15-04-1976
			BE 819039 A	16-12-1974
			CH 571905 A	30-01-1976
			CS 208701 B	15-09-1981
			DD 112916 A	12-05-1975
			ES 430085 A	01-04-1977
			FR 2243034 A	04-04-1975
			GB 1479957 A	13-07-1977
			JP 1258849 C	12-04-1985
			JP 50054566 A	14-05-1975
			JP 59028412 B	12-07-1984
			NL 7411768 A	11-03-1975
			SE 389041 B	25-10-1976
			SE 7409779 A	10-03-1975
			SU 532322 A	15-10-1976
GB 982694	A		NONE	