



(86) Date de dépôt PCT/PCT Filing Date: 2010/09/17  
 (87) Date publication PCT/PCT Publication Date: 2012/03/22  
 (45) Date de délivrance/Issue Date: 2016/02/16  
 (85) Entrée phase nationale/National Entry: 2013/02/06  
 (86) N° demande PCT/PCT Application No.: US 2010/049249  
 (87) N° publication PCT/PCT Publication No.: 2012/036694

(51) Cl.Int./Int.Cl. *H01Q 5/28* (2015.01),  
*H01Q 13/10* (2006.01), *H01Q 21/30* (2006.01),  
*H01Q 5/371* (2015.01)

(72) Inventeurs/Inventors:  
 WANG, DONG, CA;  
 RAO, QINJIANG, CA;  
 WARDEN, JAMES PAUL, US

(73) Propriétaire/Owner:  
 BLACKBERRY LIMITED, CA

(74) Agent: MOFFAT & CO.

(54) Titre : STRUCTURE A RAYONNEMENT COMPACTE POUR ANTENNES A RECEPTION SIMULTANEE  
 (54) Title: COMPACT RADIATION STRUCTURE FOR DIVERSITY ANTENNAS

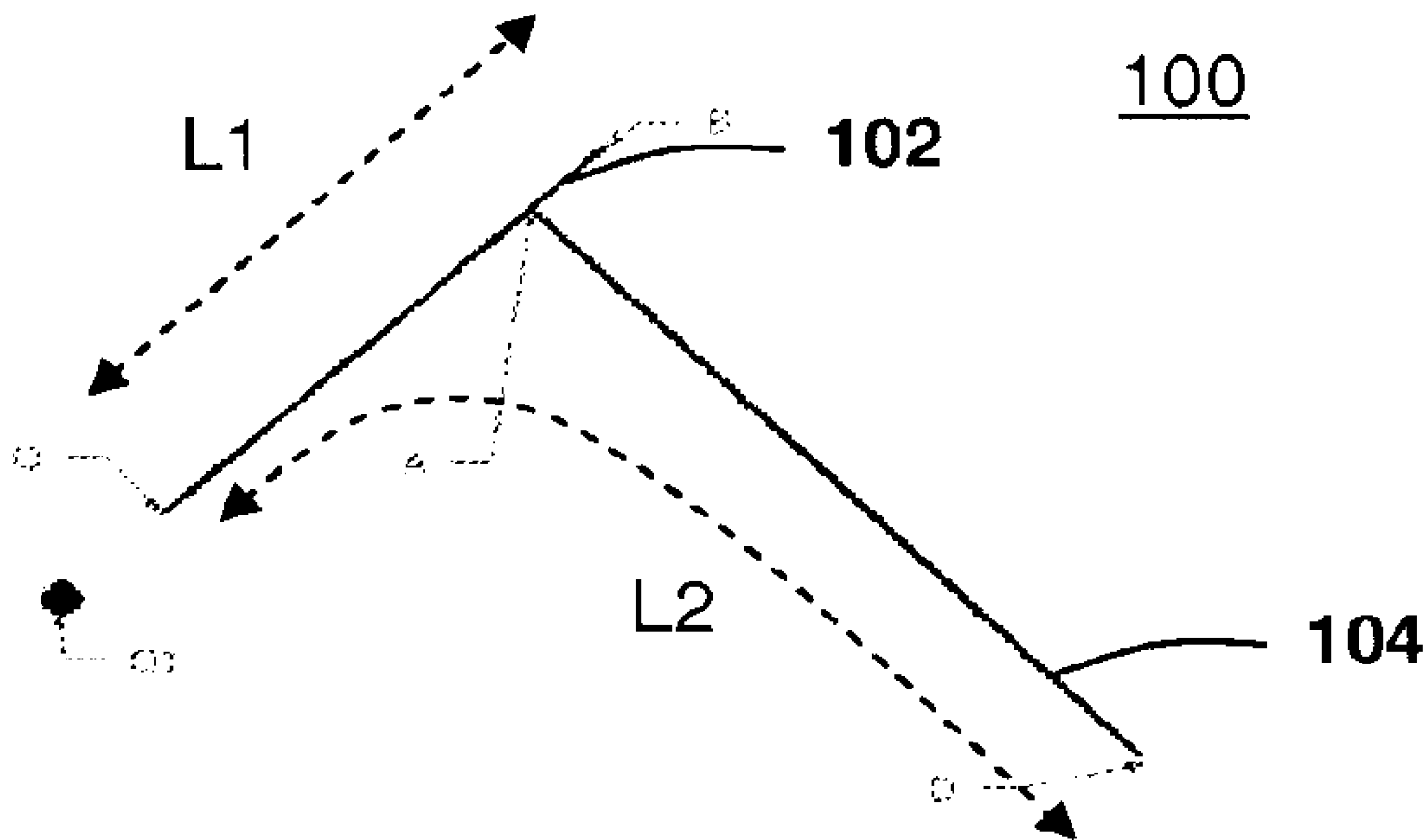

(57) Abrégé/Abstract:

An antenna for diversity operation comprising a plurality of connected antenna units (100). The antenna units each having a first radiation element (102) with length of a quarter of a wavelength at a first operating frequency a second radiation element (104) with length of a quarter of a wavelength at a second operating frequency distinct from the first operating frequency, the second radiation element sharing with the first radiation element a segment of the first radiation element. A feed point for coupling a feed to one of said first or second radiation elements such that the elements resonate at the first and second operating frequencies respectively and at substantially orthogonal polarizations. Diversity antennas configured with two or more of the antenna units.

## ABSTRACT

An antenna for diversity operation comprising a plurality of connected antenna units (100). The antenna units each having a first radiation element (102) with length of a quarter of a wavelength at a first operating frequency a second radiation element (104) with length of a quarter of a wavelength at a second operating frequency distinct from the first operating frequency, the second radiation element sharing with the first radiation element a segment of the first radiation element. A feed point for coupling a feed to one of said first or second radiation elements such that the elements resonate at the first and second operating frequencies respectively and at substantially orthogonal polarizations. Diversity antennas configured with two or more of the antenna units.

**COMPACT RADIATION STRUCTURE FOR DIVERSITY ANTENNAS****FIELD OF THE DISCLOSURE**

**[0001]** The present invention relates to the field of communications systems, and, more particularly, to base station antennas for mobile wireless communications and related methods.

**BACKGROUND**

**[0002]** Antenna diversity techniques utilize two or more antennas to improve the quality and reliability of signals received or transmitted over a wireless link. A majority of wireless environments are urban environments in which signals are reflected along multiple paths before finally being received. Each of these bounces can introduce phase shifts, time delays, attenuations, and even distortions that can destructively interfere with one another at the aperture of a receiving antenna. Antenna diversity is especially effective at mitigating these multipath situations.

**[0003]** Furthermore antenna diversity allows the capacity of the system to be increased by using different bands or spatial regions within which to send or receive signals— for example by allocating different spatial regions for different channels allows the reuse of the same frequency band. Thus, antenna diversities (frequency, polarization, radiation pattern and spatial) are being explored for current and future multiple antenna smart wireless communication systems, such as LTE (long term evaluation) and MIMO (multiple input and multiple output).

**[0004]** Cellular standards like the third generation partnership program (3GPP) long term evolution (LTE), ultra-mobile broadband (UMB), high speed downlink packet access (HSDPA) and IEEE 802.16e (WiMAX) support multiple-input multiple-output (MIMO) wireless communication technology. MIMO uses multiple antennas at the transmitter and receiver along with advanced digital signal processing to improve link quality and capacity. Existing base stations use antenna arrays to provide transmit and receive diversity

**[0005]** Recently, studies on microstrip antennas have focused on frequency reuse and polarization diversity of the two-orthogonal polarizations to double the capacity of communication systems and reduce the multi-path fading of received signals in land-based mobile communications.

[0006] Moreover, dual-frequency microstrip antenna arrays, often realized through a multilayer architecture, have gained considerable interest. However, there have been some inherent challenges in the design and architecture of dual-polarized dual-frequency band microstrip antenna arrays.

[0007] Conventionally, a dual-polarized microstrip antenna is realized by feeding a patch at the two orthogonal edges. This feeding approach requires two feeding-networks for two individual polarization components, respectively. But it is difficult to allocate enough space to accommodate two sets of feeding networks if a dual-polarized array is to be employed within a limited allowable space. Strong mode coupling and high cross polarization is likely to occur. This problem exacerbated if active and passive circuits are required to be integrated into the feed-networks.

[0008] Furthermore, if a dual-frequency operation for the above dual-feed dual-polarized array is realized by multilayered architecture, the size and complexity of the array will be further increased.

[0009] Designers of antennas for mobile communications face significant challenges, particularly since antennas must be capable of covering as many bands as possible while being small in size and still having a high performance.

#### **BRIEF DESCRIPTION OF THE DRAWINGS**

[0010] The present disclosure will be better understood with reference to drawings in which:

**FIG. 1** shows a plan view of a basic configuration of a dual frequency antenna unit according to an embodiment of the present matter;

**FIG.'s 2a-d** shows respectively plan views of a leaf, meander line, square and triangle configuration of the antenna unit of **FIG. 1**;

**FIG.'s 3a-b** show respectively a plan and side view of a multiport diversity antenna configuration using the dual frequency antenna unit according to an embodiment of the present matter;

**FIG.'s 4a-b** show respectively a plan and side view of a single port diversity antenna configuration using the dual frequency antenna unit according to a still further embodiment of the present matter

**FIG.'s 5a-b** show plan views of further configurations of the diversity antenna of **FIG. 3** and **Fig.4**;

**FIG.'s 6a-b** show respectively a plan and side view of a single port dipole diversity antenna configuration using the dual frequency antenna unit according to a further embodiment of the present matter;

**FIG.'s 7a-b** show respectively a plan and side view of a two port dipole diversity antenna according to another embodiment of the present matter;

**FIG.'s 8a-b** show respectively a plan and side view of a fourth diversity antenna configuration using the dual frequency antenna units according to another embodiment of the present matter;

**FIG.'s 9a-b** show graphs of a reflection parameter for the antenna of **FIG. 4**;

**FIG. 10** shows a far field polarization pattern for the antenna of **FIG. 4** at one of the dual-bands;

**FIG.'s 11a-b** show far field polarization patterns of the antenna of **FIG. 7** when the respective first and second ports are activated; and

**FIG. 12** shows a functional block diagram of a wireless communication system in which an embodiment of the present matter is operable.

#### **DETAILED DESCRIPTION**

**[0011]** In the following description like numerals refer to like structures illustrated in the drawings. It is to be noted that the term radiation as used herein is non directional and implies a capability of both transmission and reception unless otherwise stated.

**[0012]** In accordance with an aspect of the present matter there is provided an antenna for diversity operation comprising a plurality of connected antenna units. The antenna units each having a first radiation element with length of a quarter of a wavelength at a first operating frequency a second radiation element with length of a quarter of a wavelength at a second operating frequency distinct from the first operating frequency, the second radiation sharing with the first conductor a segment of the first conductor. A feed point for coupling a feed to one of said first or second radiation elements such that the elements resonate at the first and second operating frequencies respectively and at substantially orthogonal polarizations.

**[0013]** In accordance with a further aspect the first radiation element is a straight line having first and second ends and the second radiation element is arranged with an open end partially encircling the first radiation element.

**[0014]** In a further aspect the antenna includes a parasitic element arranged in proximity to the first end of the first radiation element.

[0015] In a further aspect the radiation elements are conductors and in another aspect the radiation elements are slots.

[0016] In a still further aspect a four port antenna diversity monopole antenna is configured with the plurality of antenna units formed on a substrate arranged with their first conductors connected together at a common connection point at the respective second ends, the antenna units so connected are symmetric relative to at least one symmetry axes and the substrate is spaced from a common ground plane. In a still further aspect a single port polarization diversity dipole antenna is configured with two pairs of antenna units formed on a substrate and arranged to be symmetric relative to at least one symmetry axes with each of the pairs having their respective second ends connected for forming a feed point.

[0017] In a still further aspect a dual port polarization diversity dipole antenna is configured with two pairs of antenna units formed on a substrate and arranged with antennas in a pair along respective crossing axis, with respective pairs (along the same axis) having their second ends connected to a feed.

[0018] Referring to **FIG. 1** there is shown schematically a basic configuration of a dual frequency antenna unit **100** according to an embodiment of the present matter. In this embodiment, the antenna unit **100** has a pair of wireline conductors **102** and **104** comprising the two radiation elements formed on a surface of suitable planar substrate (not shown) such as FR4. The wireline conductors are etched, painted or otherwise formed upon the substrate. The pair of wireline conductors **102** and **104** are formed with different physical lengths **L1** and **L2** each corresponding to about a quarter (1/4) wavelength of a desired operating frequency at the fundamental or dominant mode. The dual operating frequencies are usually the respective resonant frequencies when exciting the antenna in its fundamental mode. It is to be noted that with coupling the lengths may be a little longer or shorter than a ¼ wavelength and the electrical length of the conductors change with different operating modes, also the electrical length is different for higher modes of operation. The first conductor **102** has first and second ends labeled **O** and **B** respectively. The second conductor **104** has third and fourth ends labeled **O** and **D** respectively. The second conductor **104** extends from the first conductor **102** at a position labeled **A** such that the first and second conductors **102,104** share a portion of their lengths i.e. **O-A** or **B-A** depending on the particular configuration (described later). The second conductor **104** is arranged upon the substrate having its fourth end **D** extending away from the first conductor **102**. The position of **A** is generally

closer to the end B and is usually determined at design time using a suitable simulator as is known in the art.

**[0019]** A feed connection may be made at one of the ends **O**, **B** and **D** of the conductors or at a position along the length of the conductors **102**, **104**, depending on the particular application as will be discussed below.

**[0020]** A shorting pin (not shown) to a ground conductor may be connected at one of the ends **O**, **B**, **D** or **A** of the radiating conductors **102**, **104** depending on the particular application as will be discussed below.

**[0021]** A patch element **O1** may be arranged, again depending on the application, on the surface of the substrate **106** in a region proximate one of the ends of the conductors, preferably at the first end **O**. The patch **O1** behaves as parasitic element and has one of different geometries, such as a line, rectangle or circle depending on a desired response for the antenna. The configuration and placement of the patch element **O1** is usually modeled and determined at design time based on a particular response desired.

**[0022]** The antenna unit **100** may be used with or without a ground conductor depending on the application and the feed arrangement as will be described later.

**[0023]** The resonant frequencies of the antenna unit may be easily changed by changing the physical lengths of the conductors **102**, **104**.

**[0024]** In the exemplary implementation, the first conductor **102** is a straight line and the second conductor **104** is arranged with its open end **D** partially encircling the first conductor **102** as shown in **FIG. 2a-d**. This provides a more compact antenna arrangement and allows two or more of the antenna units **100** to be configured into an array, or into a diversity antenna configuration disposed upon a generally planar substrate, of dimensions permitting its positioning within a housing of limited volume.

**[0025]** In the present description radiation element traces are referred to for convenience however the present description also applies equally well if the radiation element traces are replaced with slots etched into a metal plate, having the same shapes as the traces. In other words the electrical dipoles and monopoles described herein could as well be implemented as magnetic dipoles or monopoles.

**[0026]** Referring now to **FIG. 2a**, there is shown an embodiment of the antenna unit **200** wherein the first conductor is a straight line **202** and the second conductor **204** is a curve, taking on the appearance of a leaf. **FIG. 2b** illustrates another embodiment of the antenna unit **210** wherein the first **212** and second **214** conductors are meander lines, which allow an increase in electrical length of the conductors. **FIG 2c** illustrates a

further embodiment **220** of the antenna unit wherein the first conductor **222** is a straight line and the second conductor **224** forms a rectangle or square shape around a portion of the first conductor **222** and **FIG. 2d** illustrates a still further embodiment **230** of the antenna unit wherein the second conductor **234** is triangular in shape with an apex of the triangle on an axis extending through the first conductor **232**.

**[0027]** The antenna units **100**, **200**, **210**, **220** and **230** may be used to construct various diversity antennas. Specifically the antenna units are arranged in a somewhat star like configuration with various combinations of feed points, ground plane and shorting pins to form a variety of diversity antennas as described below. For ease of description, the antenna unit **200** will be used to exemplify various diversity configurations below.

**[0028]** Referring now to **FIG. 3a** and **FIG. 3b**, there is shown a dual frequency diversity antenna **300** configured with four interconnected antenna units **200**. As shown in the plan view of **FIG. 3a** the four antenna units **200** are arranged with their straight line conductors **OB** connected together at a common respective second ends **B** such that the antenna units so connected are symmetric relative to two mutually orthogonal symmetry axes **302**, **304**. The diversity antenna **300** is formed on a substrate **306** and spaced from a common ground plane **308** as illustrated in the side view **FIG. 3b**. Feeds **P1**, **P2**, **P3** and **P4** are connected to each of the respective first ends **O** of the antenna units and a shorting pin **310** is connected from the common second end **B** at a common connection point **P5** to ground. The ground plane in this configuration defines a reflector that is separated from the conductive elements that are disposed upon the substrate **306** and separated by an air gap of distance **h**. In the embodiment, coaxial or similar connectors **312** are positioned in the substrate upon which the ground plane **308** is formed with their center conductors connected to the respective feeds **P1**, **P2**, **P3** and **P4**. In this configuration the antenna **300** is a four feed (four port) dual frequency diversity antenna. The air gap between the end **D** of the second conductors and the first conductors in the region **A** provides capacitive coupling between the two ends of the gap. The spacing of the gap may be optimized during simulation so that it has reasonable values for different operating bands. Similarly the air gap **h** may also be optimized.

**[0029]** In a further embodiment (not shown) which is a variation of the embodiment of **FIG. 3**, the common connection point **P5** may be left open or a matching network with lumped elements may be connected to it.

[0030] Referring to **FIG. 4a** and **FIG. 4b** there is shown plan and side views, respectively of a still further embodiment of a diversity antenna **400**. The diversity antenna **400** is configured with four antenna units **200**, similar to the diversity antenna **300** shown in **FIG. 3**; however the shorting pin **310** of **FIG. 3** is instead replaced by a single feed (single port) at the common connection point **P5** and the ground plane **308**. The remaining connections **P1**, **P2**, **P3** and **P4** are left open. Accordingly, in this configuration the antenna **400** is a single feed dual polarization monopole antenna with four cross arms. Thus the diversity antenna **400** provides two dual frequency crossing monopoles with a shared feed.

[0031] Referring to **FIG.'s 5a** and **5b** there is shown configurations of diversity antennas comprising two antenna units and three antenna units, respectively for which a feed configuration similar to **FIG.'s 3** or **4** may be implemented.

[0032] Referring to **FIG.'s 6a** and **6b** there is shown respective top and side views of a dual-band crossing dipole antennas **600** configured with two pairs **602**, **604** and **607**, **608** of interconnected antenna units **200** for providing a polarization diversity antenna **600**. The antenna units are arranged upon a substrate **606** to be symmetric relative to two mutually orthogonal symmetry axes **610**, **612**. As illustrated in the side view **FIG. 6b**, a ground conductor is not employed and the feed connector **614** is connected with its central conductor **616** connected to adjacent pair of antenna units **602**, **604** and the return or ground connection **618** is connected to the other pair of adjacent antenna units **607**, **608**. The diversity antenna **600** in this configuration operates as two dual-band crossing dipoles sharing a feed for polarization diversity.

[0033] Referring to **FIG 7a** and **7b** there is shown respective top and side views of a two port dual polarization dipole antenna **700** according to a further embodiment of the present matter. As will be seen this antenna **700** is similar in configuration to the dipole antenna arrangement **600** configured with two pairs **702**, **704** and **707**, **708** of interconnected antenna units along two crossing axis **710**, **711**, except that the single feed is replaced with a two feed arrangement **714** and **716**. The feeds **714** and **716** are connected to opposite pairs of antenna units to form two dipole antennas **704**, **702** and **707**, **708**.

[0034] Referring now to **FIG. 8**, there is shown a side view of a diversity antenna configuration for an ultra-wideband polarization diversity antenna **800**. The ultra-wideband polarization diversity antenna **800** is configured with four interconnected antenna units **200**, designated **802**, **804**, **807** and **808**. The antenna units **200** are

arranged upon a planar substrate (not shown) with their straight line conductors **OB** connected together at a common respective second ends **B 809** to be symmetric relative to two mutually orthogonal symmetry axes **810, 812**. The configured diversity antenna conductors are mounted over a plane of a ground conductor **813** and orthogonally thereto. A feed connector **814** is connected through the ground plane with its central conductor **816** connected to a feed point **811** on the second conductor **204** of one of the antenna units located at a point closest to the ground plane conductor. The ground plane **813** in this configuration defines a reflector that is separated from the conductive elements by a distance **d** measured from the closest point of the conductor **204** to the ground plane **813**. As may be seen the antenna **800** radiates energy in both the horizontal and vertical planes and all planes in between. Thus the diversity antenna **800** provides ultra-wideband polarization diversity antenna.

[0035] As mentioned earlier, each of the antenna units may employ a parasitic element **O1** for fine tuning of the radiation pattern of the diversity antenna by varying a length, width or diameter of the patch element.

[0036] Referring to **FIG.'s 9a** and **9b** there is shown a plot of the s-parameter at each of the operating frequencies **f1** and **f2** for a single port multiband and multi polarization monopole corresponding to the antenna configuration **400** of **FIG 4**.

[0037] Referring to **FIG. 10** there is shown a three dimensional far field plot at one of the operation frequencies **f1** of the antenna **400**. As may be seen maximum gain occurs in a region encircling the antenna **400** in an x-y plane parallel to the plane of the substrate **306**.

[0038] Referring to **FIG.'s 11a** and **11b** there is shown a three dimensional far field antenna gain plot for the respective dipoles of the antenna **700** of **FIG. 7** without the parasitic elements. As is seen, the plots shows each of the dipoles have a polarization pattern along the axis (x and y) of the pairs of antennas forming the dipole. With a result that the diversity antenna **700** exhibits two polarizations which are mutually orthogonal i.e. in an x-z plane and a y-z plane.

[0039] While the above embodiments have been described with respect to the antenna unit **200** shown in **FIG. 2a**, it is understood that the other antenna unit arrangements may be used as for example shown in **FIG.'s 2b-d**. Furthermore other numbers than four antenna units may be also be implemented without departing from the scope of the present matter. Thus it may be seen that the present antenna unit provides a compact radiation structure that may be used to configure various single or multiport diversity

antennas which may be used in a wireless communication system. . Furthermore, an advantage of the present matter is that the multiport arrangements may be directly fed without need for complex feed networks.

**[0040]** Exemplary components of a wireless communications system **1200** in which one or more of the above-described antennas may be used are now described with reference to **FIG. 12**. The system can consist of multiple base stations (BS's) **1202** communicating with one or more mobile device **1204**. The mobile devices **1204** may also have the capability to communicate with other computer systems on the Internet (not shown). Depending on the exact functionality provided, the mobile device **1204** that might be used by users in a wireless communications network can include both mobile terminals, such as mobile telephones, personal digital assistants, handheld computers, portable computers, laptop computers, tablet computers and similar devices, and fixed terminals such as residential gateways, televisions, set-top boxes and the like. Such devices are referred to as user equipment or UE **1204**.

**[0041]** The transmission equipment in the base station **1202** transmits signals throughout a geographical region sometime defined as a cell. Advanced network access equipment might include, for example, an enhanced node-B (eNB) rather than a base station or other systems and devices that are more highly evolved than the equivalent equipment in a traditional wireless telecommunications system. Such advanced or next generation equipment is typically referred to as long-term evolution (LTE) equipment.

**[0042]** The BS **1202** may include a multi-antenna **1206** arrangement according to one or more embodiments of the present matter, coupled to a transmitter **1208** part of an RF interface that may be used to communicate with the UEs via for example an OFDM MIMO air interface, although the embodiments are not limited in this respect. The BS **1202** and the UE **1204** may include elements similar to existing communication devices such as coding/modulation or detection/demodulation logic, Fast Fourier Transform (FFT)/Inverse FFT logic, and/or other components as suitably desired.

**[0043]** The BS or the UE could include MAC processor that communicates with RF interface to process receive/transmit signals and may include an analog-to-digital converter for down converting received signals, a digital-to-analog converter for up converting signals for transmission, and optionally, a baseband processor for physical link layer processing of respective receive/transmit signals. A MAC processor could perform medium access control and data link layer processing. Further, a MAC processor would include an uplink scheduler, in combination with additional circuitry

such as buffer memory scheduling buffer. The MAC processor and scheduling buffer may function to queue, de-queue or otherwise schedule MAC Source Data Units (SDUs) for uplink transmission to the BS.

**[0044]** An implementation of the BS includes precoding and beam-forming logic to maximize the signal level. Beam forming implies that multiple antennas **1206** are used to form the transmission or reception beam; in this way, the signal-to-noise ratio at the UE is decreased. This technique can both be used to improve coverage of a particular data rate and to increase the system spectral efficiency. Thus, beam forming can be applied to both the downlink and the uplink. The UE **1204** can report the channel state information (CSI) back to the base station to use for subsequent transmissions. In a closed-loop beam-forming MIMO system, the BS utilizes the channel information feedback from the UE to form a beam towards the UE using precoding weights (e.g., a pre-coding matrix extracted from a channel matrix).

**[0045]** At the BS **1202**, various polarization arrays may be used depending on the transmission strategies employed. Furthermore optimization procedures may be used to determine values for the antenna parameters like inter-element spacing, cross-polarization isolation and port-to-port isolation.

**[0046]** The embodiments described herein are examples of structures, systems or methods having elements corresponding to elements of the techniques of this application. This written description may enable those skilled in the art to make and use embodiments having alternative elements that likewise correspond to the elements of the techniques of this application. The intended scope of the techniques of this application thus includes other structures, systems or methods that do not differ from the techniques of this application as described herein, and further includes other structures, systems or methods with insubstantial differences from the techniques of this application as described herein.

**CLAIMS:**

1. An antenna for diversity operation comprising:  
a plurality of connected antenna units each having:  
5 a first radiation element with length of a quarter of a wavelength at a first operating frequency;  
a second radiation element with length of a quarter of a wavelength at a second operating frequency distinct from said first operating frequency, the second radiation element sharing with said first radiation element a segment of said first radiation element; and  
10 a feed point for coupling a feed to one of said first or second radiation elements such that the elements resonate at said first and second operating frequencies respectively and at substantially orthogonal polarizations.
2. The antenna of claim 1 wherein the first radiation element is a straight line having first  
15 and second ends and the second radiation element is arranged with an open end partially encircling the first radiation element.
3. The antenna of claim 2 wherein the first and second radiation elements are meander  
lines.  
20
4. The antenna of claim 2 wherein the second radiation element is a meander line.
5. The antenna of claim 2 wherein the second radiation element forms a perimeter of a  
rectangle around a portion of the first radiation element.  
25
6. The antenna of claim 2 wherein the second radiation element forms a perimeter of a  
triangle around a portion of the first radiation element.
7. The antenna of claim 1 including a parasitic element arranged in proximity to a first end  
30 of said first radiation element.
8. The antenna of claim 7 said parasitic element geometric configuration being selected from one of a line, rectangle or circle.

9. The antenna of claim 2, wherein said plurality of antenna units are formed on a substrate arranged with their first radiation elements connected together at a common connection point at said respective second ends, the antenna units so connected are symmetric relative to at least one symmetry axes and the substrate is spaced from a common ground plane.
10. The antenna of claim 9, including a plurality of feed points each located at said first end of the respective antenna units.
11. The antenna of claim 10, including a shorting pin connected from said common connection point to said ground plane.
12. The antenna of claim 10, wherein said feed is located at said common feed point and said second ends are open.
13. The antenna of claim 2, having two pairs of antenna units formed on a substrate and arranged to be symmetric relative to at least one symmetry axes with each of said pairs having their respective second ends connected for forming said feed point.
14. The antenna of claim 10, said plurality of antenna units are formed on a substrate arranged with their first radiation elements connected at a common connection point at said respective second ends, the antenna units so connected are symmetric relative to at least one symmetry axes, said substrate being mounted orthogonally to a plane of a ground conductor; and  
said feed point being at a radiation element of one of the antenna units in closest distance to the ground plane conductor.
15. The antenna of claim 1, wherein the radiation elements are conductors.
16. The antenna of claim 1, wherein the radiation elements are slots.
17. A wireless communication system comprising an antenna as claimed in any one of claims 1 to 16.

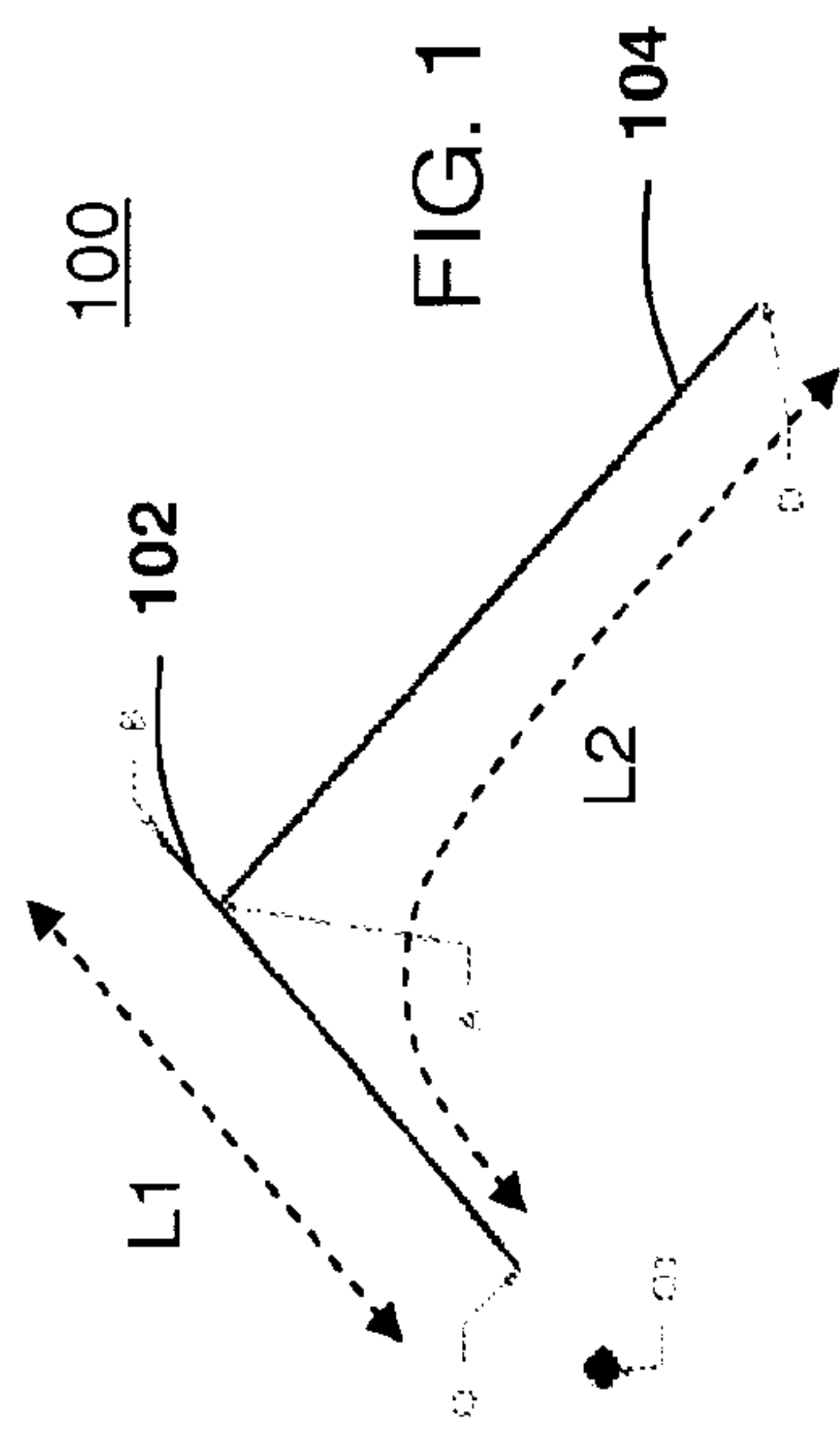

FIG. 1

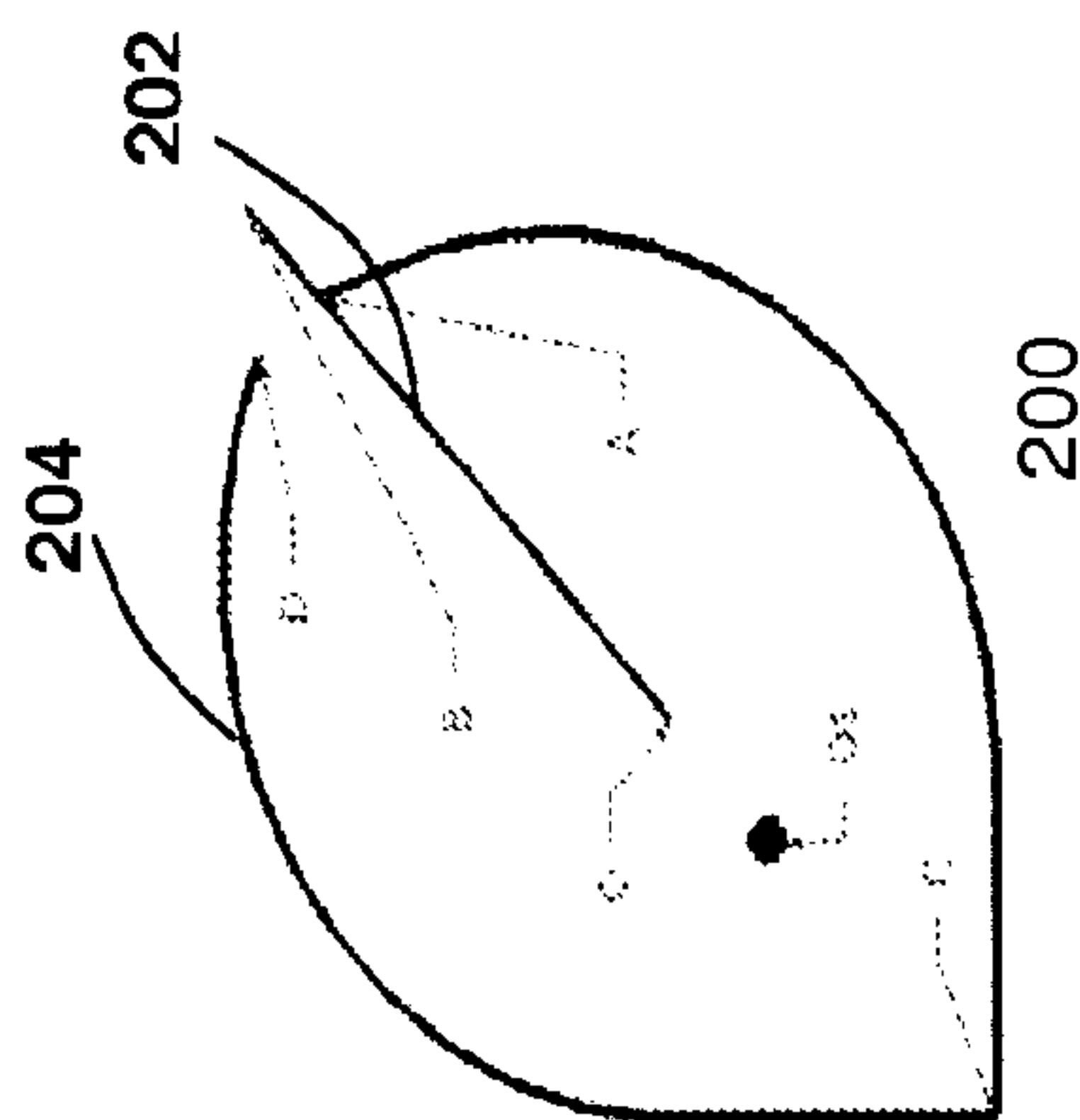

FIG. 2a

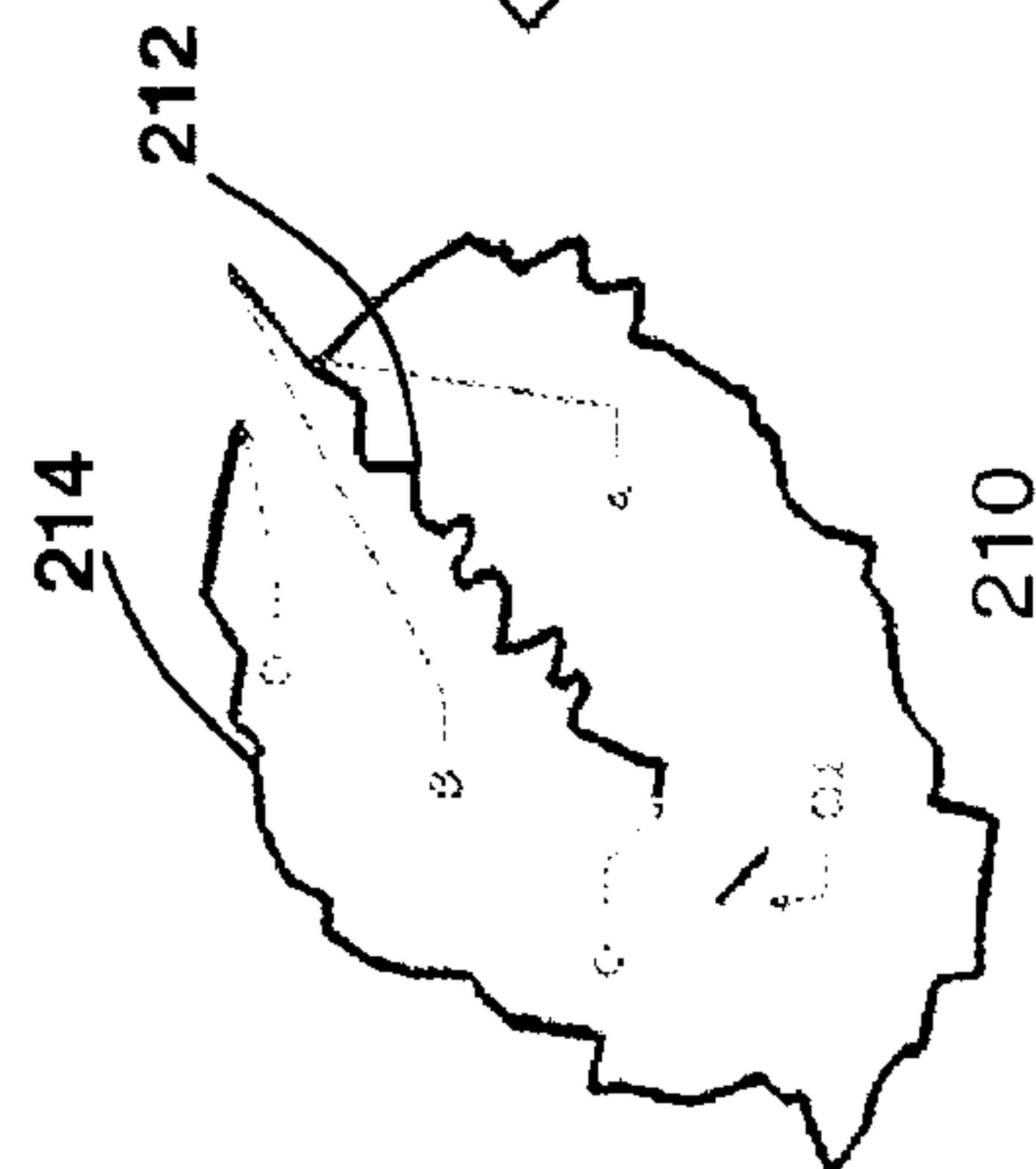

FIG. 2b

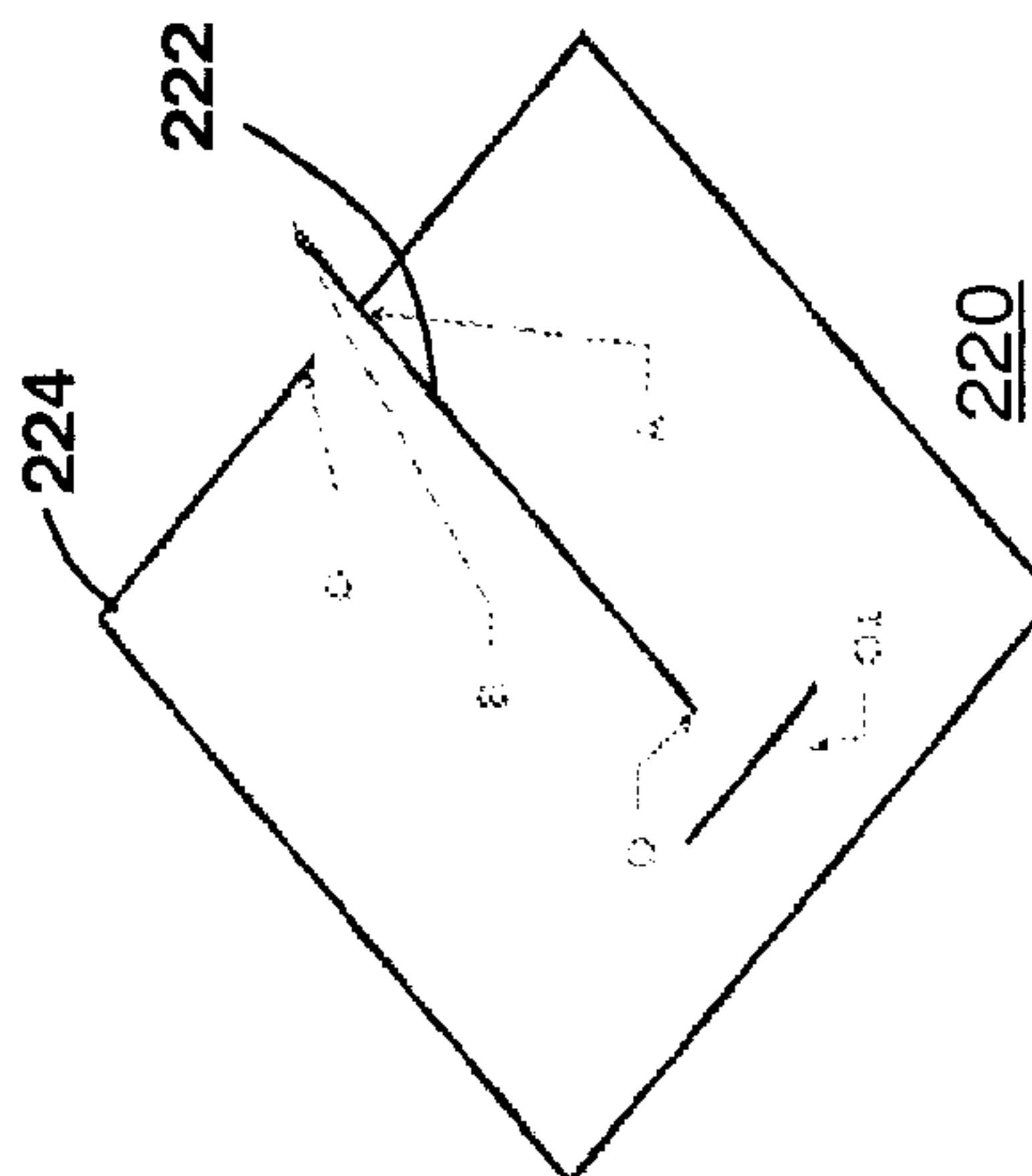

FIG. 2c

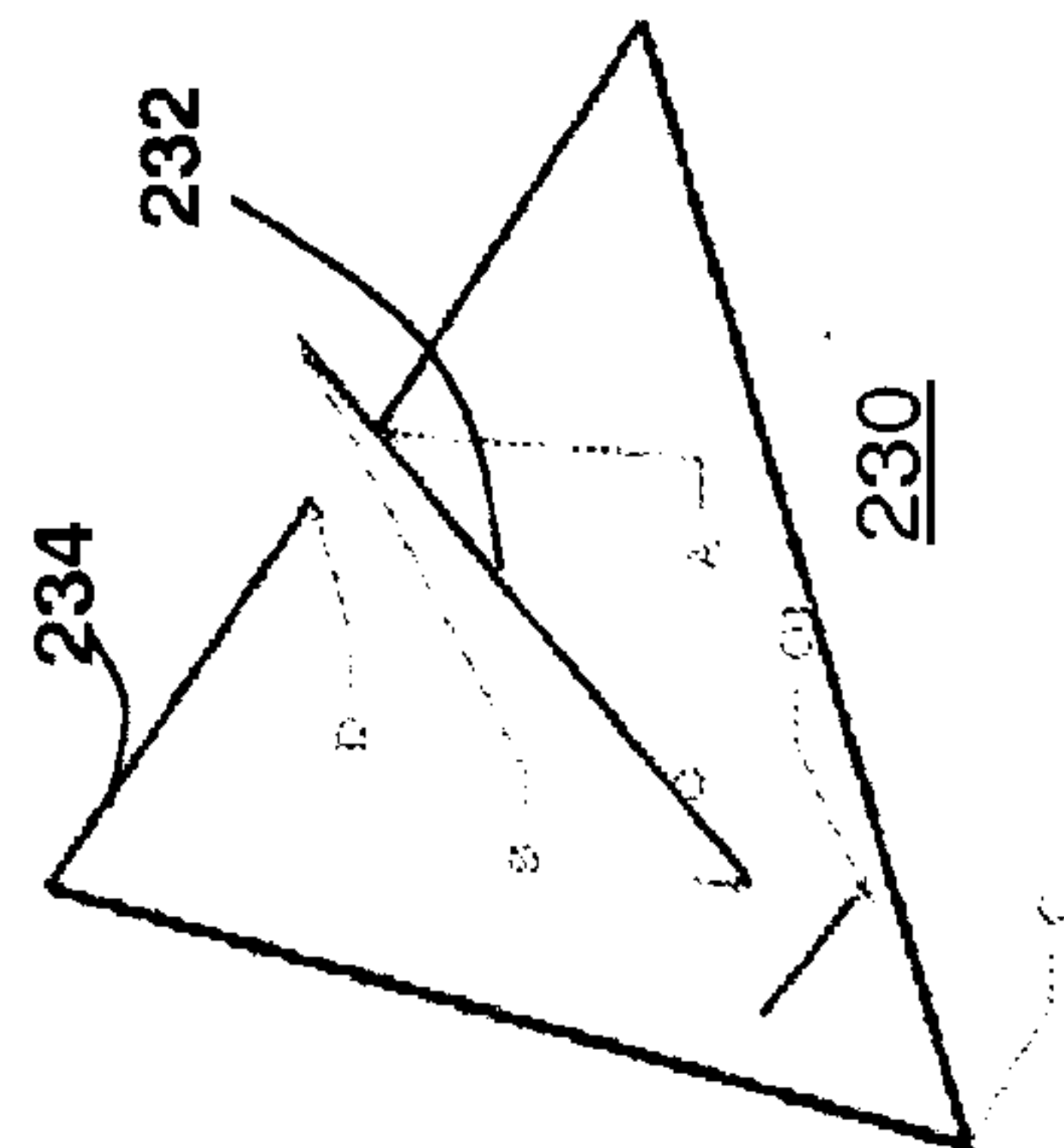
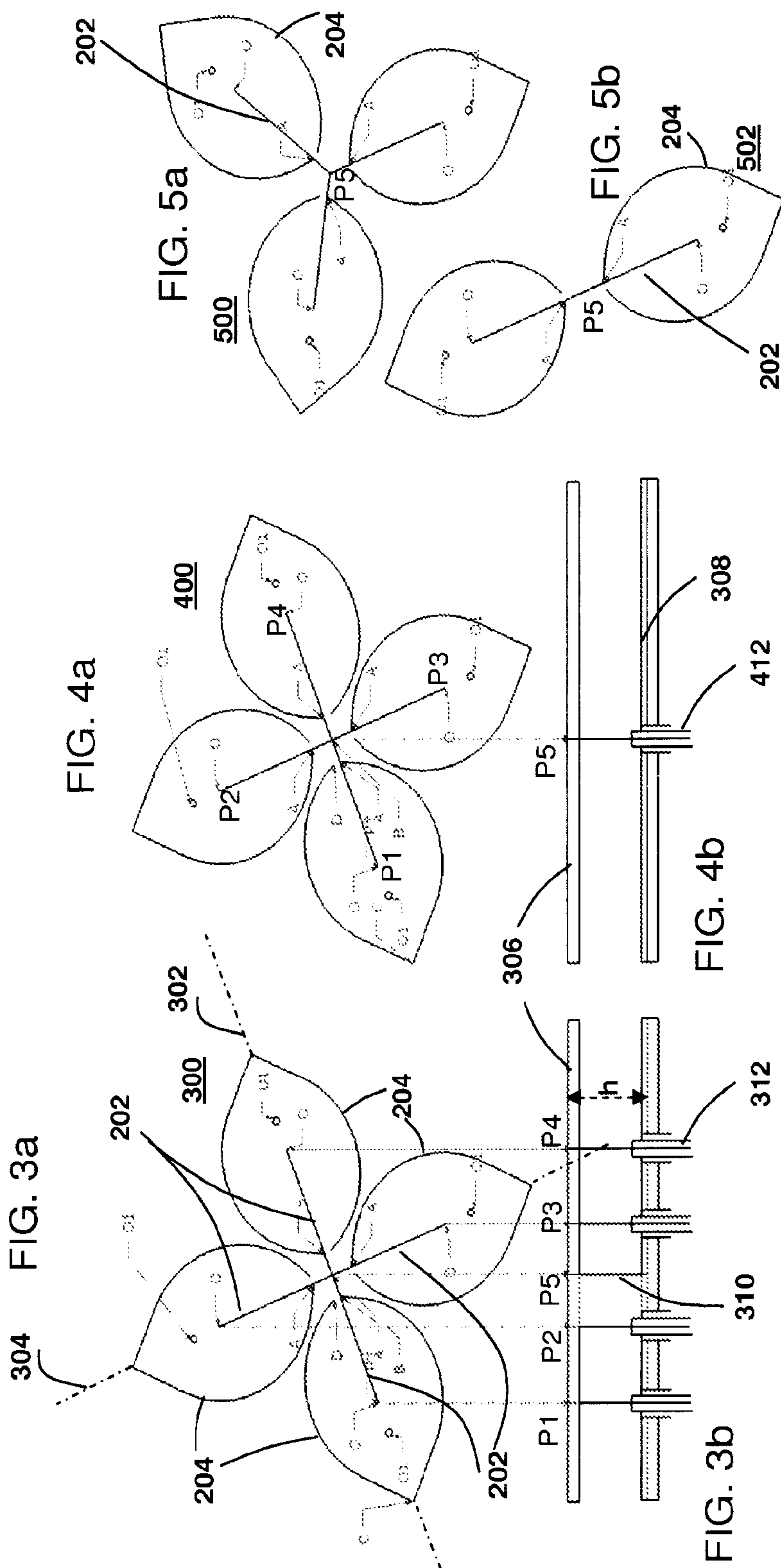
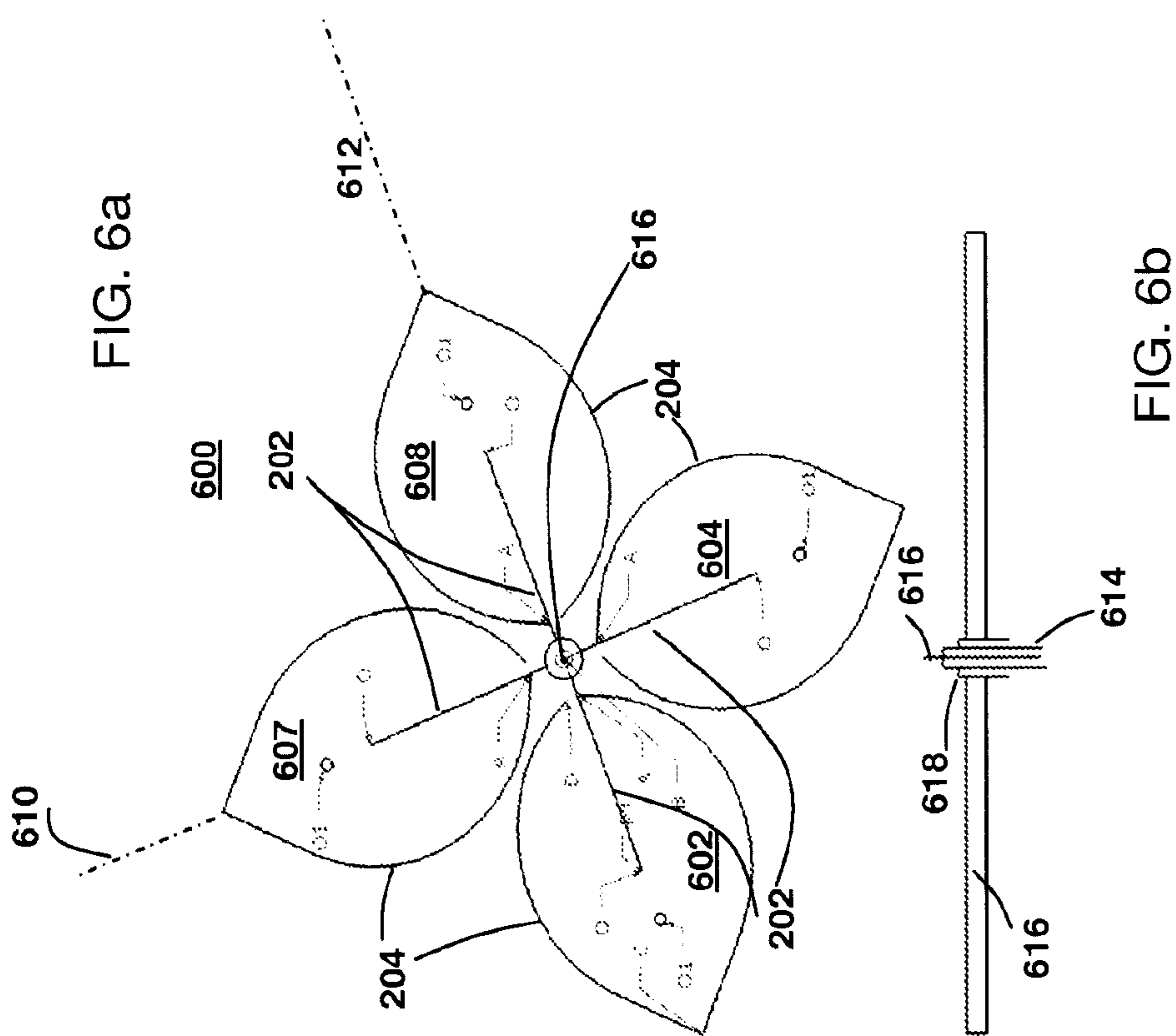
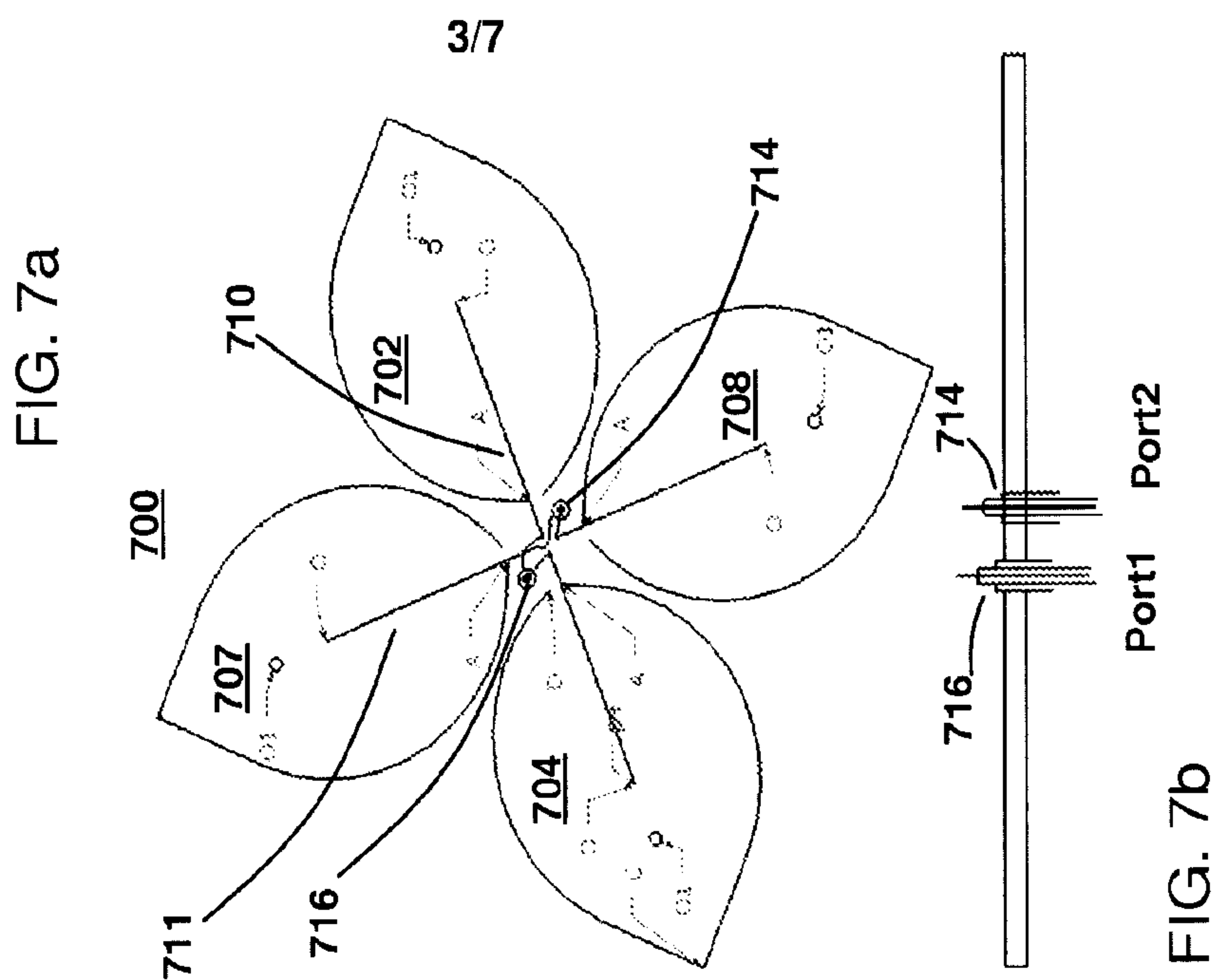

FIG. 2d





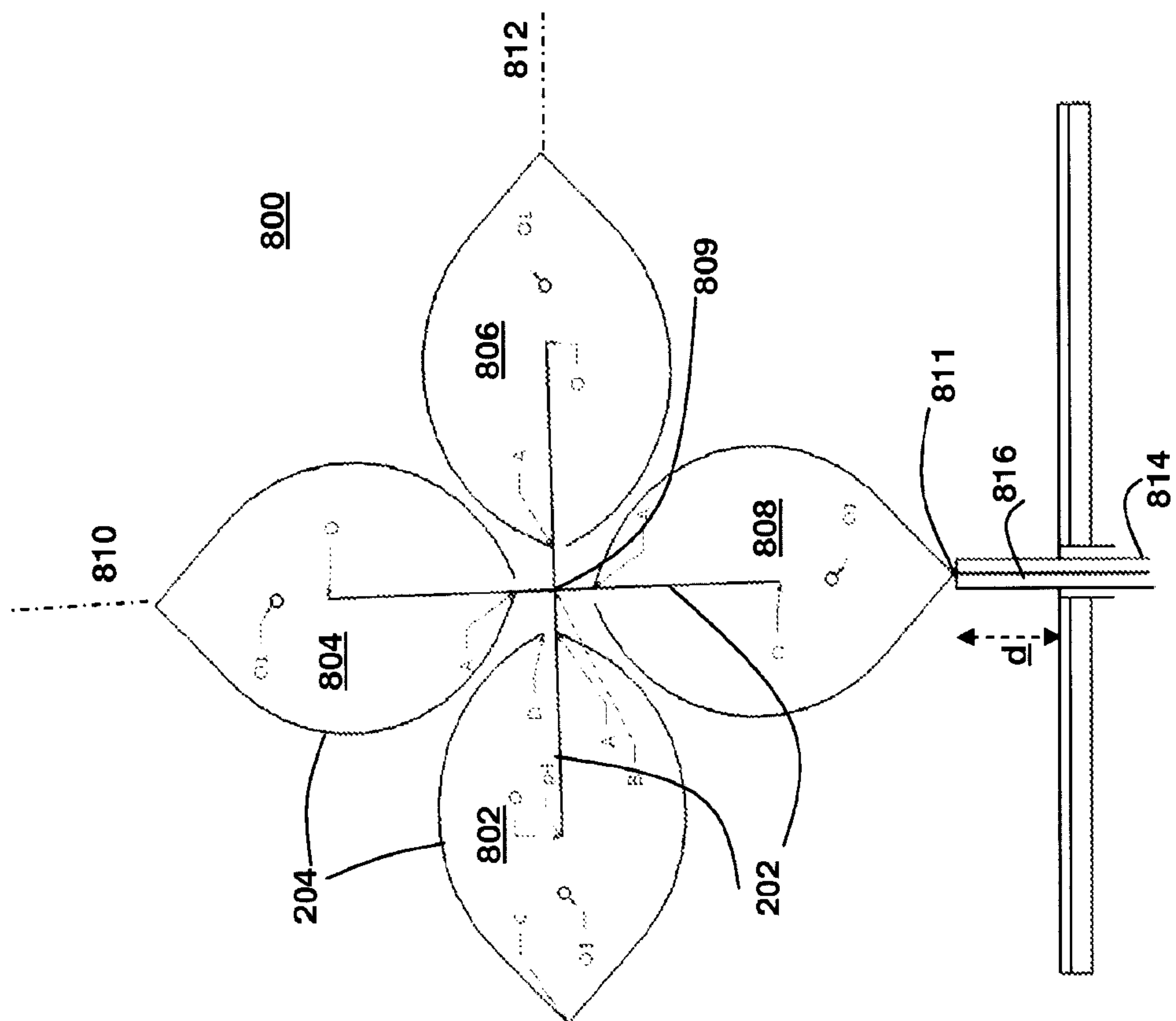

FIG. 8

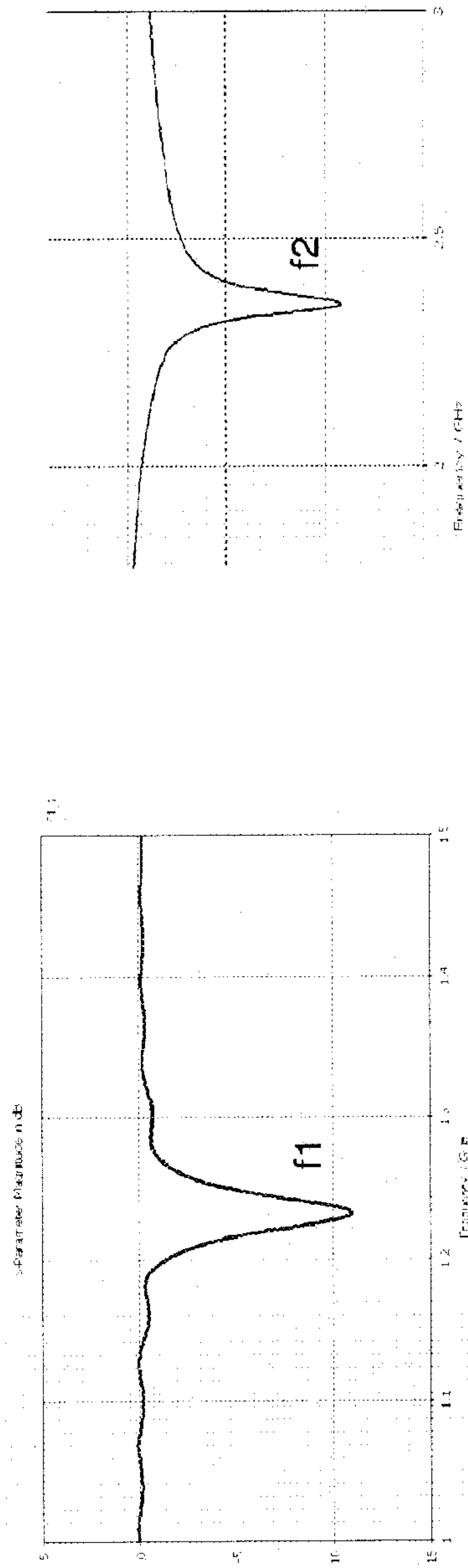

Fig. 9a

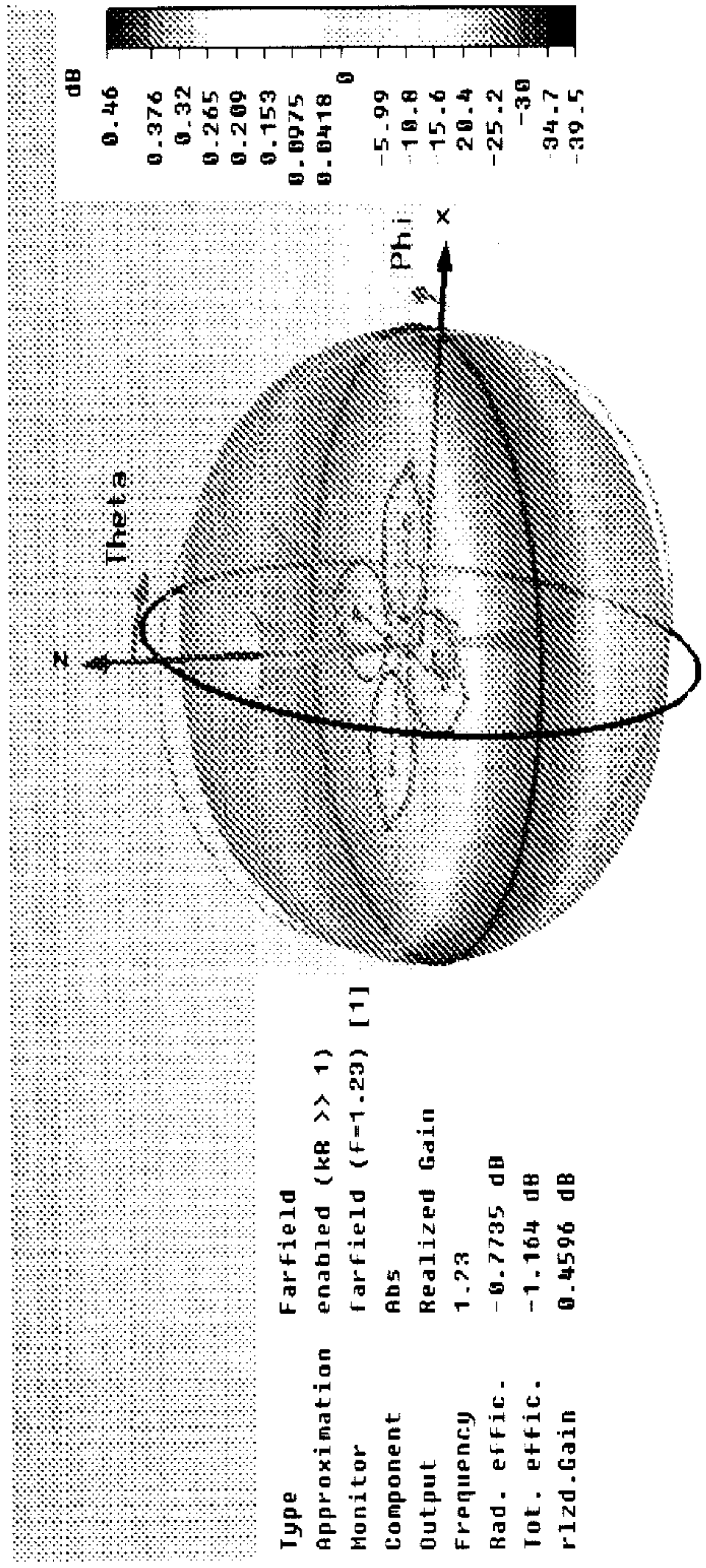
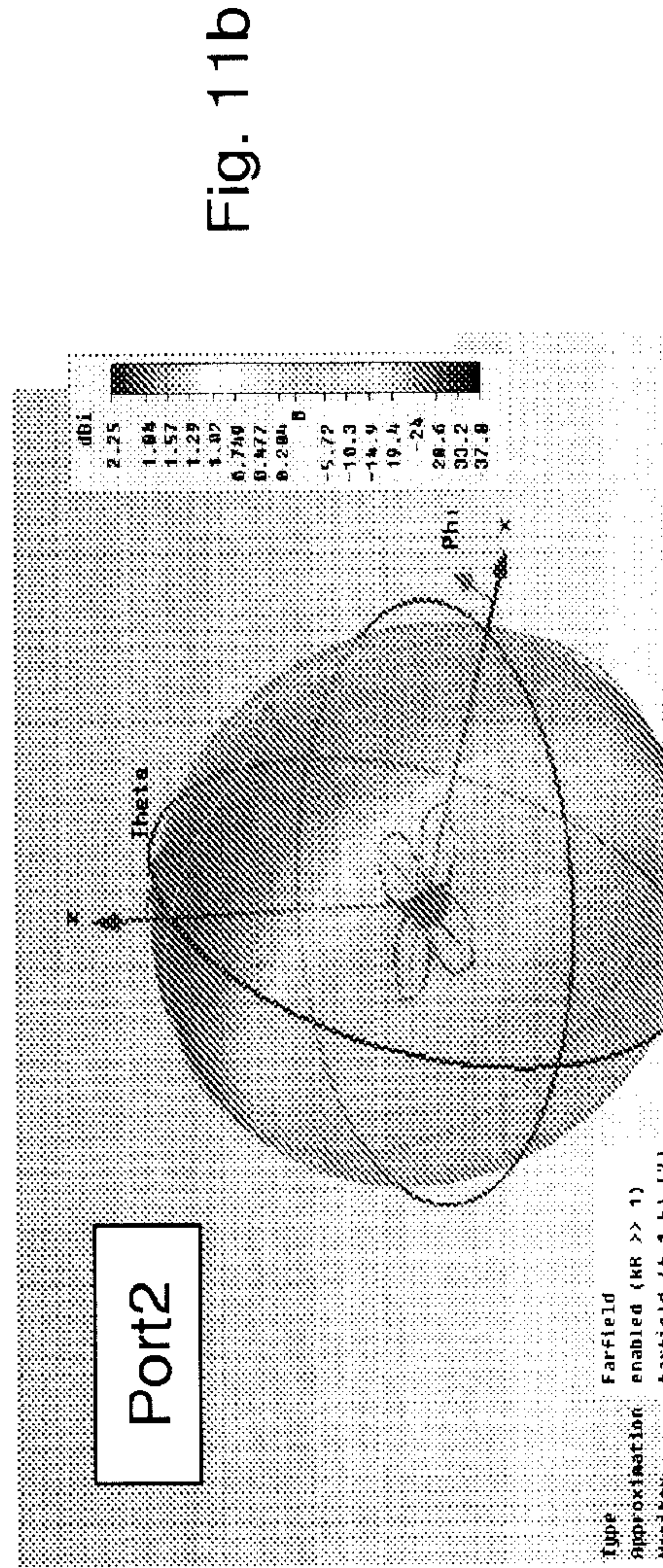
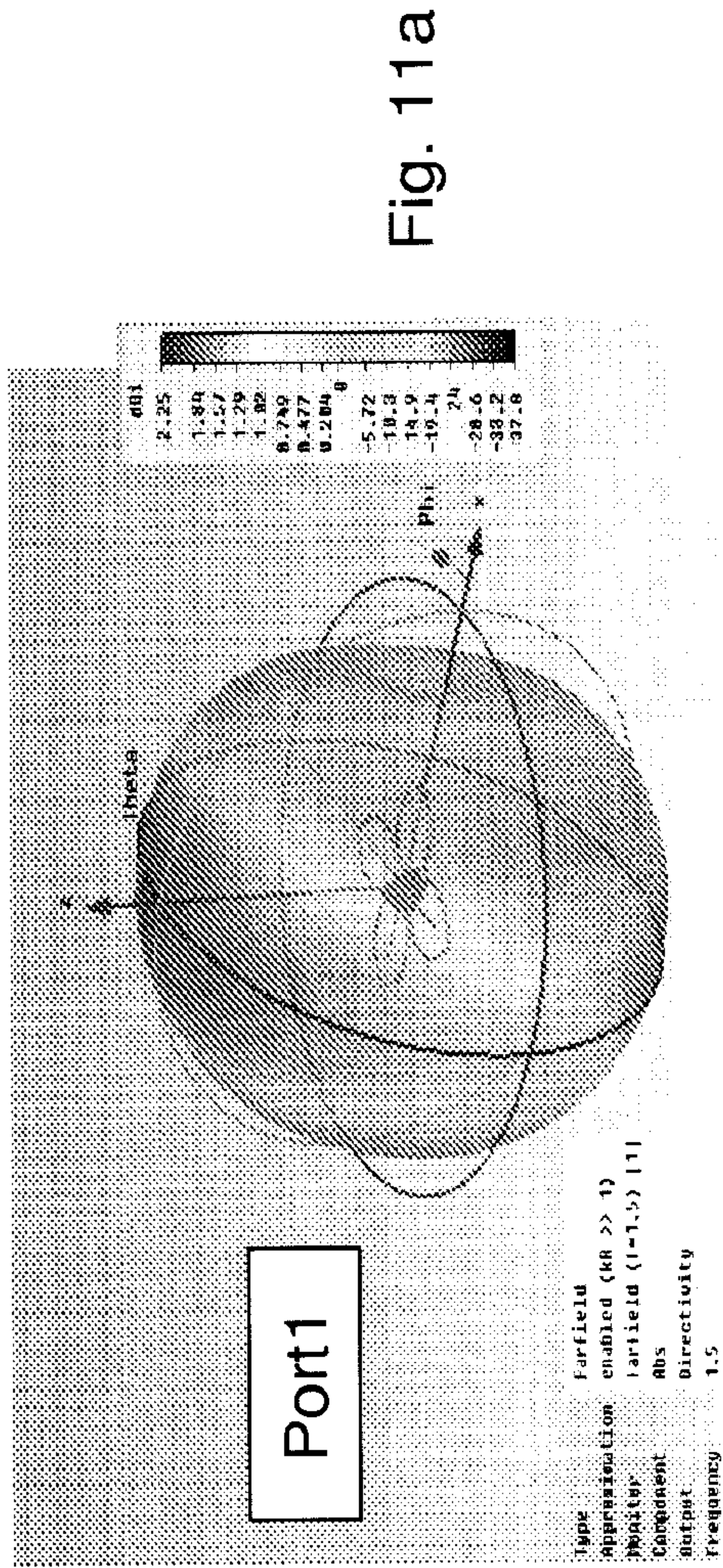

Fig. 10



7/7

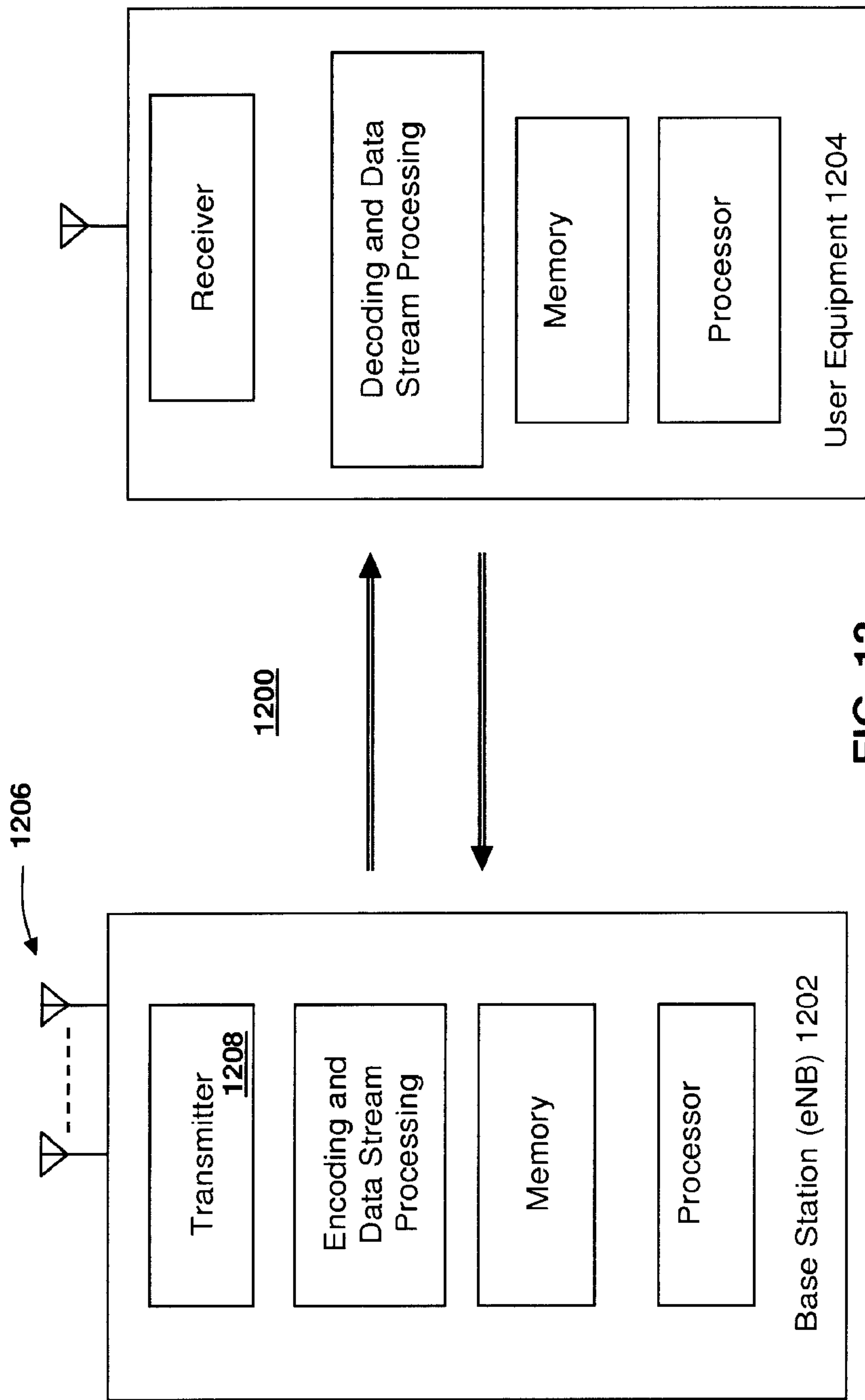

FIG. 12

