



(51) International Patent Classification:

H01R 13/6585 (2011.01) H01R 12/71 (2011.01)
H01R 24/60 (2011.01) H01R 13/6594 (2011.01)
H01R 13/504 (2006.01)

(21) International Application Number:

PCT/US2015/025661

(22) International Filing Date:

14 April 2015 (14.04.2015)

(25) Filing Language:

English

(26) Publication Language:

English

(30) Priority Data:

61/979,469	14 April 2014 (14.04.2014)	US
62/001,060	21 May 2014 (21.05.2014)	US
62/129,826	7 March 2015 (07.03.2015)	US
14/683,134	9 April 2015 (09.04.2015)	US

(71) Applicant: **APPLE INC.** [US/US]; 1 Infinite Loop, M/S 169-3IPL, Cupertino, California 95014 (US).

(72) Inventors: **TZIVISKOS, George**; 1 Infinite Loop, M/S 306-4PD, Cupertino, California 95014 (US). **LEE, Jae Hwang**; 1 Infinite Loop, M/S 306-4PD, Cupertino, Cali-

fornia 95014 (US). **AMINI, Mahmoud R.**; 1 Infinite Loop, M/S 306-4PD, Cupertino, California 95014 (US). **HACK, Paul J.**; 1 Infinite Loop, M/S 306-4PD, Cupertino, California 95014 (US). **GAO, Zheng**; 1 Infinite Loop, M/S 306-4PD, Cupertino, California 95014 (US). **ZHOU, Rui**; 1 Infinite Loop, M/S 87-2PD, Cupertino, California 95014 (US).

(74) Agents: **ZIGMANT, J. Matthew** et al.; Kilpatrick Townsend & Stockton LLP, Eighth Floor, Two Embarcadero Center, San Francisco, California 94111 (US).

(81) Designated States (unless otherwise indicated, for every kind of national protection available): AE, AG, AL, AM, AO, AT, AU, AZ, BA, BB, BG, BH, BN, BR, BW, BY, BZ, CA, CH, CL, CN, CO, CR, CU, CZ, DE, DK, DM, DO, DZ, EC, EE, EG, ES, FI, GB, GD, GE, GH, GM, GT, HN, HR, HU, ID, IL, IN, IR, IS, JP, KE, KG, KN, KP, KR, KZ, LA, LC, LK, LR, LS, LU, LY, MA, MD, ME, MG, MK, MN, MW, MX, MY, MZ, NA, NG, NI, NO, NZ, OM, PA, PE, PG, PH, PL, PT, QA, RO, RS, RU, RW, SA, SC, SD, SE, SG, SK, SL, SM, ST, SV, SY, TH, TJ, TM, TN, TR, TT, TZ, UA, UG, US, UZ, VC, VN, ZA, ZM, ZW.

[Continued on next page]

(54) Title: DURABLE CONNECTOR RECEPTACLES

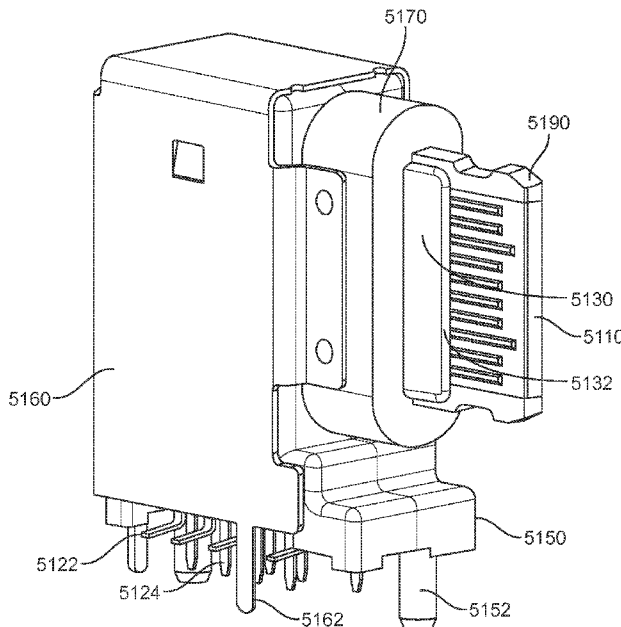

FIG. 51

(57) Abstract: Connector receptacles that are able to withstand insertion and other forces, are reliable, and are easy to manufacture. In various examples, the connector receptacle tongue or other portions may be reinforced such that they may withstand the insertion forces exerted through a connector insert.

WO 2015/160744 A4

(84) Designated States (*unless otherwise indicated, for every kind of regional protection available*): ARIPO (BW, GH, GM, KE, LR, LS, MW, MZ, NA, RW, SD, SL, ST, SZ, TZ, UG, ZM, ZW), Eurasian (AM, AZ, BY, KG, KZ, RU, TJ, TM), European (AL, AT, BE, BG, CH, CY, CZ, DE, DK, EE, ES, FI, FR, GB, GR, HR, HU, IE, IS, IT, LT, LU, LV, MC, MK, MT, NL, NO, PL, PT, RO, RS, SE, SI, SK, SM, TR), OAPI (BF, BJ, CF, CG, CI, CM, GA, GN, GQ, GW, KM, ML, MR, NE, SN, TD, TG).

Published:

- *with international search report (Art. 21(3))*
- *with amended claims (Art. 19(1))*

(88) Date of publication of the international search report:

28 January 2016

Date of publication of the amended claims:

26 May 2016

AMENDED CLAIMS

received by the International Bureau on 16 February 2016 (16.02.2016)

- 1 1. A connector receptacle comprising:
2 a tongue comprising:
3 a metallic piece, the metallic piece comprising:
4 side portions to form sides of the tongue;
5 a cross-brace between the side portions; and
6 a first ground contact on a top of the tongue and a second ground
7 contact on a bottom of the tongue, wherein the ground contacts are formed with the
8 side portions and the cross-brace as a single piece;
9 a nonconductive insert portion in the metallic piece and around the cross-
10 brace;
11 a plurality of signal contacts on the nonconductive insert portion, the signal
12 contacts having contacting portions between the first and second ground contacts and a front
13 of the tongue; and
14 a housing supporting the nonconductive insert portion.
- 1 2. The connector receptacle of claim 1 wherein the side portions of the
2 metallic piece are exposed.
- 1 3. The connector receptacle of claim 2 wherein the nonconductive insert
2 is formed around the cross-brace.
- 1 4. The connector receptacle of claim 1 wherein the inner sides of the side
2 portions each have a groove and the nonconductive insert portion is arranged to slide along
3 the groves when the nonconductive insert portion is inserted into the metallic piece during
4 assembly.
- 1 5. The connector receptacle of claim 3 wherein the metallic piece is
2 formed using metal-injection molding.
- 1 6. The connector receptacle of claim 1 wherein the housing is formed of
2 injection-molded plastic.
- 1 7. A connector receptacle comprising:
2 a tongue, the tongue comprising:

3 a metallic center piece having a center portion, the center portion having a
4 right extension and a left extension,
5 wherein the left extension is folded over the tongue to form a first ground
6 contact on a top surface of the tongue, the left extension having a rear extension folded to
7 form a second ground contact, and
8 wherein the right extension is folded under the tongue to form a third ground
9 contact on a bottom surface of the tongue, the right extension having a rear extension folded
10 to form a fourth ground contact, the tongue further comprising:
11 a first molded portion around the center portion of the metallic center piece;
12 a plurality of contacts in the first molded portion;
13 a second molded portion over a rear of the first molded portion, the second
14 molded portion leaving a portion of the plurality of contacts, the first ground contact, the
15 second ground contact, and the third ground contact exposed.

1 8. The connector receptacle of claim 7 wherein the metallic center piece
2 further comprises a rear extension, the rear extension comprising a plurality of tabs.

1 9. The connector receptacle of claim 7 wherein the center portion further
2 comprises folded side portions to provide reinforcement for sides of the tongue.

1 10. The connector receptacle of claim 9 wherein the second molded
2 portion leaves an outside edge of the folded side portions exposed.

1 11. The connector receptacle of claim 9 wherein the center portion further
2 comprises a folded front portion to provide reinforcement for the front of the tongue.

1 12. The connector receptacle of claim 7 wherein the contacts are placed in
2 the first molded portion before the second molded portion is formed.

1 13. A connector receptacle comprising:
2 a tongue, the tongue comprising:
3 a plurality of contacts
4 a metallic center portion,
5 an upper metallic portion forming a first ground contact spaced above the
6 metallic center portion and a second ground contact spaced between the first ground contact
7 and the metallic center portion,

8 a lower metallic portion forming a third ground contact spaced below the
9 metallic center portion and a fourth ground contact spaced between the third ground contact
10 and the metallic center portion; and

11 a molded portion over the metallic center portion leaving a portion of the
12 plurality of contacts, the first ground contact, the second ground contact, the third ground
13 contact, and the fourth ground contact exposed.

1 14. The connector receptacle of claim 13 wherein the upper metallic
2 portion, the lower metallic portion, and the metallic center portion are attached.

1 15. The connector receptacle of claim 14 wherein the upper metallic
2 portion, the lower metallic portion, and the metallic center portion are attached using laser-
3 welds.

1 16. The connector receptacle of claim 15 wherein the upper metallic
2 portion, the lower metallic portion, and the metallic center portion each include side tabs,
3 where the side tabs are used to align the upper metallic portion, the lower metallic portion,
4 and the metallic center portion before they are laser-welded together.

1 17. The connector receptacle of claim 16 wherein the side tabs may be
2 clamped together when the upper metallic portion, the lower metallic portion, and the
3 metallic center portion are laser-welded together.

1 18. An electronic device comprising:
2 a device enclosure having a connector receptacle, the connector receptacle
3 comprising:
4 a recess in the device enclosure, the recess having an opening in a rear
5 surface; and
6 a tongue supporting a plurality of contacts on a first side of the tongue
7 and a second side of the tongue, the tongue comprising:
8 a molded portion having a plurality of slots to support the
9 plurality of contacts; and
10 a frame around an outside of the molded portion;
11 a printed circuit board supporting a plurality of traces; and
12 an interposer to mechanically attach to the tongue to the printed circuit board
13 such that electrical connections are formed between the plurality of contacts and the plurality
14 of traces supported by the printed circuit board.

1 19. The electronic device of claim 18 wherein the tongue is formed of
2 plastic and the frame is formed of metal.

1 20. The electronic device of claim 19 wherein the contacts each form
2 approximately a ninety-degree angle such that tongue is substantially vertical and the printed
3 circuit board is substantially horizontal.

1 21. The electronic device of claim 20 wherein the interposer comprises a
2 first housing supporting a first number of the first plurality of contacts and a second housing
3 supporting a second number of the first plurality of contacts.

1 22. The electronic device of claim 21 wherein at least one of the first
2 number of the plurality of contacts has a through-hole tail portion at least one of the first
3 number of the plurality of contacts has a surface-mount tail portion.

1 23. The electronic device of claim 22 wherein the first housing and the
2 second housing are attached, the interposer further comprising:
3 a shield substantially around a top, rear, and two sides of the attached first and
4 second housing.