



(51) International Patent Classification:

A62B 1/14 (2006.01) A62B 1/18 (2006.01)
A63B 29/02 (2006.01) B66D 3/02 (2006.01)
A62B 1/08 (2006.01) B66D 3/04 (2006.01)

(21) International Application Number:

PCT/AU2016/050090

(22) International Filing Date:

12 February 2016 (12.02.2016)

(25) Filing Language:

English

(26) Publication Language:

English

(30) Priority Data:

2015900527 17 February 2015 (17.02.2015) AU

(72) Inventor; and

(71) Applicant : **ROGELJA, Boris** [AU/AU]; 20 Spalding Crescent, Hurstville Grove, New South Wales 2220 (AU).

(74) Agent: **FB RICE**; Level 23, 44 Market St, Sydney, New South Wales 2000 (AU).

AO, AT, AU, AZ, BA, BB, BG, BH, BN, BR, BW, BY, BZ, CA, CH, CL, CN, CO, CR, CU, CZ, DE, DK, DM, DO, DZ, EC, EE, EG, ES, FI, GB, GD, GE, GH, GM, GT, HN, HR, HU, ID, IL, IN, IR, IS, JP, KE, KG, KN, KP, KR, KZ, LA, LC, LK, LR, LS, LU, LY, MA, MD, ME, MG, MK, MN, MW, MX, MY, MZ, NA, NG, NI, NO, NZ, OM, PA, PE, PG, PH, PL, PT, QA, RO, RS, RU, RW, SA, SC, SD, SE, SG, SK, SL, SM, ST, SV, SY, TH, TJ, TM, TN, TR, TT, TZ, UA, UG, US, UZ, VC, VN, ZA, ZM, ZW.

(84) Designated States (unless otherwise indicated, for every

kind of regional protection available): ARIPO (BW, GH, GM, KE, LR, LS, MW, MZ, NA, RW, SD, SL, ST, SZ, TZ, UG, ZM, ZW), Eurasian (AM, AZ, BY, KG, KZ, RU, TJ, TM), European (AL, AT, BE, BG, CH, CY, CZ, DE, DK, EE, ES, FI, FR, GB, GR, HR, HU, IE, IS, IT, LT, LU, LV, MC, MK, MT, NL, NO, PL, PT, RO, RS, SE, SI, SK, SM, TR), OAPI (BF, BJ, CF, CG, CI, CM, GA, GN, GQ, GW, KM, ML, MR, NE, SN, TD, TG).

Published:

— with international search report (Art. 21(3))

(81) Designated States (unless otherwise indicated, for every kind of national protection available): AE, AG, AL, AM,

(54) Title: IMPROVED DESCENDER

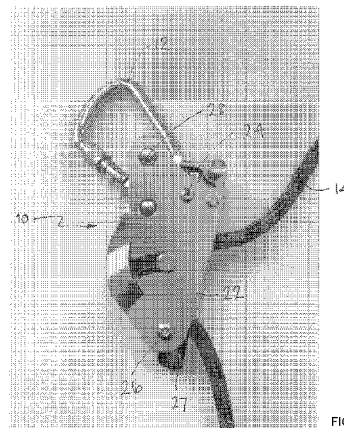

FIG. 1

(57) Abstract: A descender (10) comprises a rear or base plate (20), a front plate (22) which is fixedly mounted to the base plate, generally parallel to and spaced from the base plate and an arm (30) which is pivotally mounted to the base plate and/or the front plate for movement between the two plates. The arm (30) defines a generally curved channel (38) through which a rope (14) may pass. The channel is defined between a sheave (34) and a wall (37) of the arm and defines an entrance (38a) and an exit (38b) for the rope. The sheave (34) is pivotable about an axis, the sheave being lightly biased towards a first or rest position. Pivoting of the sheave about the axis in a first direction, away from the rest position, causes an increase in the friction applied to the rope passing through the channel, typically by causing the exit of the channel to narrow. A handle (46) is provided, operation of which may cause the sheave (34) to rotate towards its rest or neutral position thereby allowing faster passage of the rope through the descender. The descender (10) includes means for connecting the descender to a harness or the like.



IMPROVED DESCENDER**Cross-Reference to Related Applications**

[0001] The present application claims priority from Australian Provisional Patent Application No 2015900527 filed on 17 February 2015, the content of which is incorporated herein by reference.

Technical Field

[0002] The present application relates to a descender for use in abseiling and belaying and the like.

Background

[0003] Abseiling is a technique which is used to descend steep surfaces such as cliff faces and is often used by persons involved in activities such as mountain climbing, canyoning and caving. In order to abseil down a cliff face, one end of a rope is made fast at the top of the cliff and the person making the descent then slides down the rope. The rope is passed either around the body of the person or, more usually, through a descender attached to a harness worn by the person such that the passage of the rope around the body or through the descender provides sufficient friction to slow the rate of descent to a safe speed. These techniques are also used in the workplace e.g. by persons working at heights on roofs and buildings, and by rescue services.

[0004] A descender defines rope engaging services around and between which the rope travels along a tortuous path, to provide frictional engagement between the rope and the descender. The rate of descent is normally controlled by holding the free or tail end of the rope to control the tension on the rope where it emerges from the descender thereby to control the degree of friction engagement between the rope and descender, which in turn controls the rate of descent.

[0005] Descenders used in abseiling vary greatly in performance and complexity, there being a variety of relatively simple devices which rely on frictional engagement between the rope and metal rings or racks about which the rope is wrapped, and a number of more

complex descenders which incorporate a braking mechanism which allows friction between the rope and descender to be varied other than by simply controlling the free or tail end of the rope. The earliest of these more complex devices have a handle or lever which, when operated, tended to increase the friction between the descender and the rope. This type of descender had the problem that the brake was not self-engaging and therefore, if the user was knocked unconscious, he or she would fall in the same way as a user of the earlier devices.

[0006] A number of devices now include automatic braking mechanisms in which a handle is operated by a person using descender to control their speed of descent and if the handle is released, a brake actuates and prevents a user falling uncontrollably. Such a descender is disclosed in US 4,596,314.

[0007] It is known to provide a descender having a sheave around which a rope passes located between front and rear plates which pivot to open the descender to allow a rope to be threaded through. The sheave may be shaped and pivotable to control the resistance to the passage of the rope. One disadvantage to such descenders is that if the plates pivot open during use, the possibility exists that the descender could fall off the rope, if the plates are not locked in a closed position.

[0008] Any discussion of documents, acts, materials, devices, articles or the like which has been included in the present specification is solely for the purpose of providing a context for the present invention. It is not to be taken as an admission that any or all of these matters form part of the prior art base or were common general knowledge in the field relevant to the present invention as it existed before the priority date of each claim of this application.

Summary

[0009] According to the present invention there is provided a descender comprising:

a rear or base plate;

a front plate which is fixedly mounted to the base plate, generally parallel to and spaced from the base plate;

an arm which is pivotally mounted to the base plate and/or the front plate, wherein the arm defines a generally curved channel through which a rope may pass, the channel being defined between a sheave and a wall of the arm and defining an entrance and an exit for the rope, wherein the sheave is pivotable about an axis, the sheave being, typically lightly, biased towards a first or rest position, and wherein pivoting of the sheave about the axis in a first direction, away from the rest position, causes an increase in the friction applied to the rope passing through the channel, typically by causing the exit of the channel to narrow; and

wherein a handle is provided, operation of which may cause the sheave to rotate towards its rest or neutral position thereby allowing faster passage of the rope through the descender; and

wherein the descender includes means for connecting the descender to a harness or the like.

[0010] In use, when a rope passes through the descender under tension the friction caused by the rope passing through the descender causes the sheave to move away from the rest position, thus increasing the braking on the rope. Operation of the handle to pivot the sheave back towards its rest position reduces the braking force on the rope, thus it is possible to control the rate of descent. The use of fixed front and rear plates and a pivoting arm which can be pivoted out from between the plates for loading rope into the descender makes the descender inherently safer than existing descenders where the front or rear plates pivot to load rope into the descender.

[0011] In a preferred embodiment, a post/projection is mounted on the rear plate adjacent the exit to the channel.

[0012] The post provided at the exit of the descender provides an additional element that can be used to further increase resistance and slow the movement of the rope through the descender.

[0013] Typically, the means for connecting the descender to a harness or the like will be a through hole for receiving a karabiner.

[0014] In one embodiment, the handle is able to pivot through a predetermined angle from one end position to a second end position and wherein in the end positions the sheave is either unaffected by the handle or turned towards a position where the rope is subject to increased friction and wherein movement of the handle to a position intermediate the end positions causes the sheave to move towards its rest position.

[0015] Thus the operation of the handle is fail safe in the sense that at either extreme position, maximum friction is preferably applied to the rope so the fall of a user who falls unconscious and releases the handle will be braked while a user who might panic and push the lever too far would also have their fall braked.

[0016] The sheave may define a bulge or projection which when the sheave is rotated under load, restricts the exit of the channel.

[0017] The sheave may define an integral projection on its underside which passes through a typically arcuate slot in the base plate of the arm. The projection may engage in use with a projection associated with and moveable by operation of the handle, by means of which the handle is able to rotate the sheave.

Brief Description of Drawings

[0018] A specific embodiment of the present invention will now be described, by way of example only, and with reference to the accompanying drawings in which:-

Figure 1 is a front photographic view of a descender embodying the present invention, showing a rope passing through the descender, with the descender closed;

Figure 2 is a rear photographic view of the descender of Figure 1;

Figure 3 is a front photographic view of the descender of Figure, showing the descender open;

Figure 4 is a further photographic view of the descender of Figure, showing the descender open

Figure 5 is a front view of the descender of Figure, showing the descender open and without the rope;

Figure 6 is a side view of the descender of Figure 5;

Figure 7 is a rear view of the descender of Figure, showing the descender open;

Figure 8 is a schematic drawing of a handle of the descender;

Figure 9 is a schematic drawing of a connecting rod of the descender;

Figure 10 is a schematic drawing showing a rear plate of the descender and the handle showing hidden detail;

Figure 11 is a schematic drawing as shown in Figure 11 but further illustrating the interaction of the sheave with the handle via a connecting rod;

Figure 12 is a further schematic drawings illustrating the movement of the connecting rod.

Figure 13 illustrates the descender in use with a load attached to the descender using a karabiner; and

Figure 14 shows the descender in use in the opposite orientation to Figure 12 .

Description of Embodiments

[0019] Referring to the drawings, Figure 1 shows a descender 10, to which a karabiner 12 is attached, and through which a rope 14 passes.

[0020] The descender includes a rear plate 20 (refer to Figure 2) and a front plate 22. The front plate is mounted in a fixed arrangement relative to the rear plate on three fixed posts 24, 26 and 28. The posts maintain the front plate parallel to, and a fixed distance from, the rear plate. A loop 27 is pivotally mounted attached to fixed post 26 and can be used for attaching a karabiner to the descender.

[0021] With reference to Figures 3 and 5 in particular, an arm 30 is pivotally mounted about the post 26. The arm 30 defines a base plate 32 on which a shaped sheave 34 is mounted and around which a rope may pass. With reference to figure 5, the shaped sheave 34 is pivotally mounted about a pivot 36. A wall 37 extends around the curved perimeter of the arm so as to define a generally U-shaped channel/rope guide 38, having an entrance 38a and an exit 38b, extending around three sides of the sheave through which the rope may pass in use. This assists in retaining the rope in the descender, in use. Also shown is a metal insert 40 which defines a shaped curved channel which guides the passage of the rope out of the rope guide 38. The sheave is biased into the rest position shown in Figure 5 by a biasing means such as a spring (not shown). The sheave may pivot through up to about 45° in the direction of the arrow A (refer to Figure 5) which causes a narrowing of the exit channel from the descender. The sheave is generally oval but defines a bulge or salient 41 on that side of the sheave facing and adjacent the exit 38b from the channel 38, and when the sheave pivots in the direction of the arrow A, the bulge 41 moves towards the insert 40 narrowing the channel and slowing the passage of the rope through the descender.

[0022] As is best seen in Figure 7, an arcuate slot is 42 defined in the base plate 32 whose arc is centred on the pivot pin 36. A v-shaped projection 44 which is integral with the sheave 34 projects from the underside to the sheave into the slot 42. The slot defines a first end 42a and a second end 42b. The spring associated with the sheave discussed in the paragraph above, biases the projection towards the end 42a of the slot. In use, when the sheave slides on a rope is passing through the channel 38 as is described in more detail below the sheave rotates by friction with the rope which overcomes the light biasing provided by the spring and the v-shaped projection 44 is moved towards and as far the other end of the slot 42b as is described in more detail below. Operation of the handle/lever 46 moves the projection 44 back towards end 42a, in which position minimum braking is applied to the rope.

[0023] In use, the arm locates in between the two plates 20 and 22, as shown in Figures 1 and 2.

[0024] The arm also defines a depressible button/latch 50. As is best seen in Figure 5, the front plate defines a circular aperture 52. When the arm is rotated about the pivot 26 into position between the plates 20 and 22, the button/latch 50 locates in the aperture and retains

the descender closed, until it is manually depressed to overcome the button's bias to release the arm 30.

[0025] Figure 5 also shows an additional post 51 which in use is adjacent the exit of the channel and can be used to increase the twisting in the path along which the rope passes and hence can increase the friction applied to the rope when used.

[0026] As is best seen in Figure 4, the centre of the sheave co-axial with the pivot axis of the sheave defines a circular projection 54, which extends above the height of the wall 37. An arcuate guide slot 60 is defined in the plate 22 along which the projection passes as the descender is closed. The entry to the slot 60 is covered by a raised bridging portion 62, which allows the projection to pass under it and helps maintain the strength and integrity of the top plate 22.

[0027] With reference to Figures 4 and 6 in particular, it can be seen that there is a wide arcuate channel 70 defined in the surface of the lower plate 20 that faces the arm. The centre of curvature of the channel is the pivot 26. The v-shaped projection 44 passes along that channel 70 when the arm 30 is pivoted between the plates to close the descender. Also visible in the channel is a projection 72 which locates in an arcuate slot in the rear plate of the descender, as is discussed below.

[0028] Figure 8 is a drawing showing the face of the handle 46 which in faces the rear plate 22 of the descender, illustrating detail which is hidden in the assembled descender. It can be seen that the handle has a generally circular portion 47 and an integral arm/lever portion 48. The handle 46 pivots about a circular aperture 49, which is mounted on a circular pin, bolt, or the like 49a, located in the generally circular portion 47. Operation of the lever 48 rotates the handle about pivot 47. Figure 8 also shows a generally arcuate channel 100, located adjacent the aperture 49.

[0029] Figure 9 shows a connecting rod 110 which is also hidden in the assembled descender. The rod comprises a generally planar member with the cylindrical projection 72 at one end and a cylindrical projection 112 at the other end which is located in the arcuate channel 100 of the handle 46.

[0030] Figure 10 is a drawing showing just the rear plate of the descender omitting the arm and front plate but showing the outline of the hidden part of the handle 46 behind the plate 20, in dashed lines

[0031] Figure 10 shows the channel 70 in detail and that the distal closed end 70a of the channel is enlarged relative to the channel entry 70b. An arcuate/curved through slot 74 is defined adjacent the end 70a, and the cylindrical post or projection 72 extends through that slot into the channel 70.

[0032] Figures 11 and 12 illustrate the interaction of the post 72 with the sheave, specifically the projection 44 on the underside of the sheave. Figure 11 shows the sheave at an intermediate position 44 and end positions 44a and 44b corresponding to end positions 42a and 42b of the channel 42 shown in Figure 7. It will be appreciated that if the projection 72 travels along the channel in the direction of the arrow B, it will push the projection 44 from the end 44b/42b of the channel to the end 44a/42a, in which position, the least resistance is applied to the rope. It should also be noted that that position corresponds to the resting position of the sheave when it is unloaded due to the biasing spring and the sheave only rotates against the biasing when forces are applied to the sheave due to rope passing through the descender. (Clearly the descender only needs to function when in use and the resting position of the sheave when not in use is irrelevant to the safety of the device). It is also noted that the v-shaped projection 44 is constrained to move inside the channel 70, but is not constrained by the slot 74

[0033] With reference to Figure 10 turning the handle 46 in the direction B away from the body of the descender causes the post 72 to move along the slot in the direction C during the first 90° of movement and then moves it back in the opposite direction to its start position shown in Figure 10. As the handle is turned, the projection 112 can move along the slot 100 in the direction of the arrow D.

[0034] In use, with reference to Figures 5 and 10, when the rope 14 is passing through the descender and is under tension, for example because a person is using the descender to abseil down the rope, the forces on the rope cause the sheave to pivot against the biasing means and turn the sheave in the direction A which tends to slow the passage of the rope through the descender. As the sheave turns, the v-shaped projection 44 moves from the position 44a (rest)

towards 44b where it engages with the projection 74. Therefore movement of the post in the direction C causes movement of the v-shaped projection 44 in that same direction C, which in turn causes the sheave to pivot in the opposite direction to the arrow A, reducing the friction of the rope and allowing it to pass more freely through the descender.

[0035] If the handle is moved too far in the direction B the projection 74 moves back in the opposite direction to arrow C and the sheave pivots back towards its rest position in the opposite direction to the arrow A, thus slowing down the passage of rope.

[0036] The projection 112 is able to move along the slot 100. With reference to Figures 11 and 12 in particular due to the geometry of the connection and the arcuate slots 100 and 74, after the handle has been turned through more than a particular angle (approximately 45° as shown but the exact angle is not critical) the , the projection 112 will move rapidly along the slot 100 in the direction of the arrow D to the distal end 100B of the slot 100. Depending on the geometry of the slots and the connector, this will occur when the when the projection 112 is about in the centre of the slot 100 as shown in Figure 12. This will “lock” the apparatus in the braking position as a small movement of the handle will no longer release the braking and the handle will have to be turned to the rest position adjacent the body of the descender shown in Figure 10 before the pin is able to travel towards the first end 100A of the slot.

[0037] A further safety feature arising from the geometry of the connector projections and slots is that the geometry is arranged so that the position in which the descender is providing the minimum resistance, in particular, is unstable so that if the handle is released it will not remain in that position and will move thus activating the braking.

[0038] Thus the operation of the handle is fail safe in the sense that at either extreme position maximum friction is applied to the rope so the fall of a user who falls unconscious and releases the handle will be braked while a user who might panic and push the lever too far would also have their fall braked.

[0039] The post provided at the exit of the descender provides an additional element that can be used to further increase resistance and slow the movement of the rope through the descender.

[0040] The use of fixed front and rear plates and a pivoting arm which can be pivoted from between the plates for loading rope into the descender makes the descender inherently safer than versions where the front or rear plates pivot to load rope into the descender.

[0041] Figure 13 illustrates the descender in use with a load attached to the descender by a karabiner attached to the post 28 or “anchor point A”. A hand 200 is shown holding the unloaded side of the rope. The rope slides through the descender to allow slack to be taken up. Pulling on the rope can be used to haul the load upwards. When hauling, pulleys can be used to create a mechanical advantage.

[0042] Figure 14 shows the descender in use in the opposite orientation to Figure 13. In this case the karabiner is attached to the opposite end of the descender on loop 27 or “anchor point B”

[0043] The descender is able to be used in either orientation for various different rigging purposes. Pulleys or pulley kits can be attached to the upper most anchor point for use in assisting in pulling up the load. If the pulley system is released, the descender will stop the load from falling.

[0044] It will be appreciated by persons skilled in the art that numerous variations and/or modifications may be made to the above-described embodiments, without departing from the broad general scope of the present disclosure. The present embodiments are, therefore, to be considered in all respects as illustrative and not restrictive.

CLAIMS:

1. A descender comprising:

a rear or base plate;

a front plate which is fixedly mounted to the base plate, generally parallel to and spaced from the base plate;

an arm which is pivotally mounted to the base plate and/or the front plate, wherein the arm defines a generally curved channel through which a rope may pass, the channel being defined between a sheave and a wall of the arm and defining an entrance and an exit for the rope, wherein the sheave is pivotable about an axis, the sheave being biased towards a first or rest position, and wherein pivoting of the sheave about the axis in a first direction, away from the rest position, causes an increase in the friction applied to the rope passing through the channel, typically by causing the exit of the channel to narrow; and

wherein a handle is provided, operation of which may cause the sheave to rotate towards its rest or neutral position thereby allowing faster passage of the rope through the descender; and

wherein the descender includes means for connecting the descender to a harness or the like.

2. A descender as claimed in claim 1 wherein the sheave defines an integral projection on its underside which passes through a first slot in the base plate of the arm and which in use engages with a first projection associated with and moveable by operation of the handle, thus allowing the handle to rotate the sheave.

3. A descender as claimed in claim 2 wherein the base plate defines an arcuate channel which is open at one end and in which a second slot is defined and in which the first projection is located and constrained to move within.

4. A descender as claimed in claim 2 or claim 3 wherein the first projection is defined on one end of a connecting rod and the opposite end of the connecting rod defines a second projection which locates in and is constrained by a third slot in the handle.
5. A descender as claimed in any one of claims 2 to 4 wherein the first slot is arcuate.
6. A descender as claimed in any one of claims 3 to 5 wherein the second slot is arcuate
7. A descender as claimed in any one of claims 4 to 7 wherein the first slot is arcuate
8. A descender as claimed in any preceding claim wherein a projection is mounted on the rear plate adjacent the exit to the channel.
9. A descender as claimed in any preceding claim wherein the means for connecting the descender to a harness or the like is a hole for receiving a karabiner.
10. A descender as claimed in any preceding claim wherein the handle is able to pivot through a predetermined angle from one end position to a second end position and wherein in each end position the sheave is either unaffected by the handle or turned towards a position where the rope is subject to increased friction, and wherein movement of the handle to a position intermediate the end positions causes the sheave to move towards its rest position.
11. A descender as claimed in any preceding claim wherein the sheave defines a bulge or projection which when the sheave is rotated under load, restricts the exit of the channel.
12. A descender as claimed in any one of claims 4 to 11 wherein in operation after the handle has been turned through more than a predetermined angle, the second projection will move to one end of the third slot and maintain the sheave in the position in which maximum braking force is applied to the rope until the handle is turned to a start position adjacent the body of the descender to re-set the descender.
13. A descender as claimed in any one of claims 4 to 12 wherein the geometry of the connector, projections and slots is such that the position in which the descender is providing the minimum resistance, is generally unstable so that if the handle is released it will not remain in that position and will move, thus increasing or activating braking.

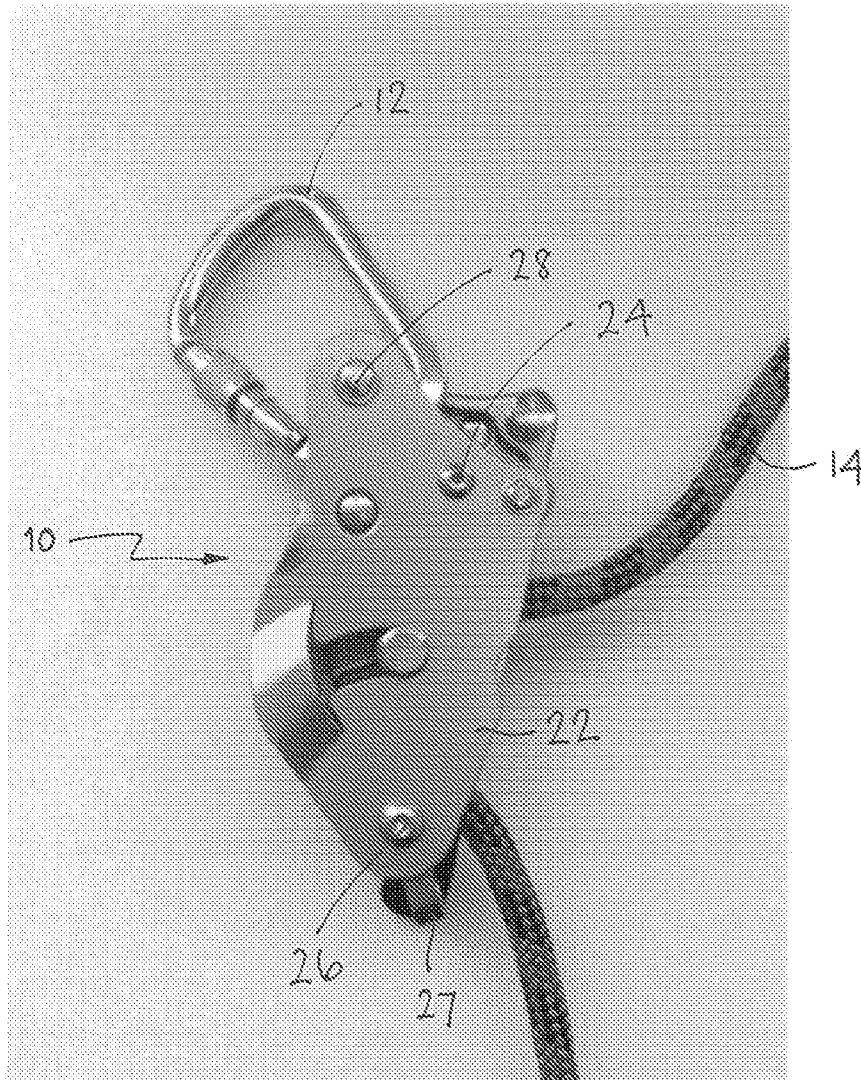

FIG. 1

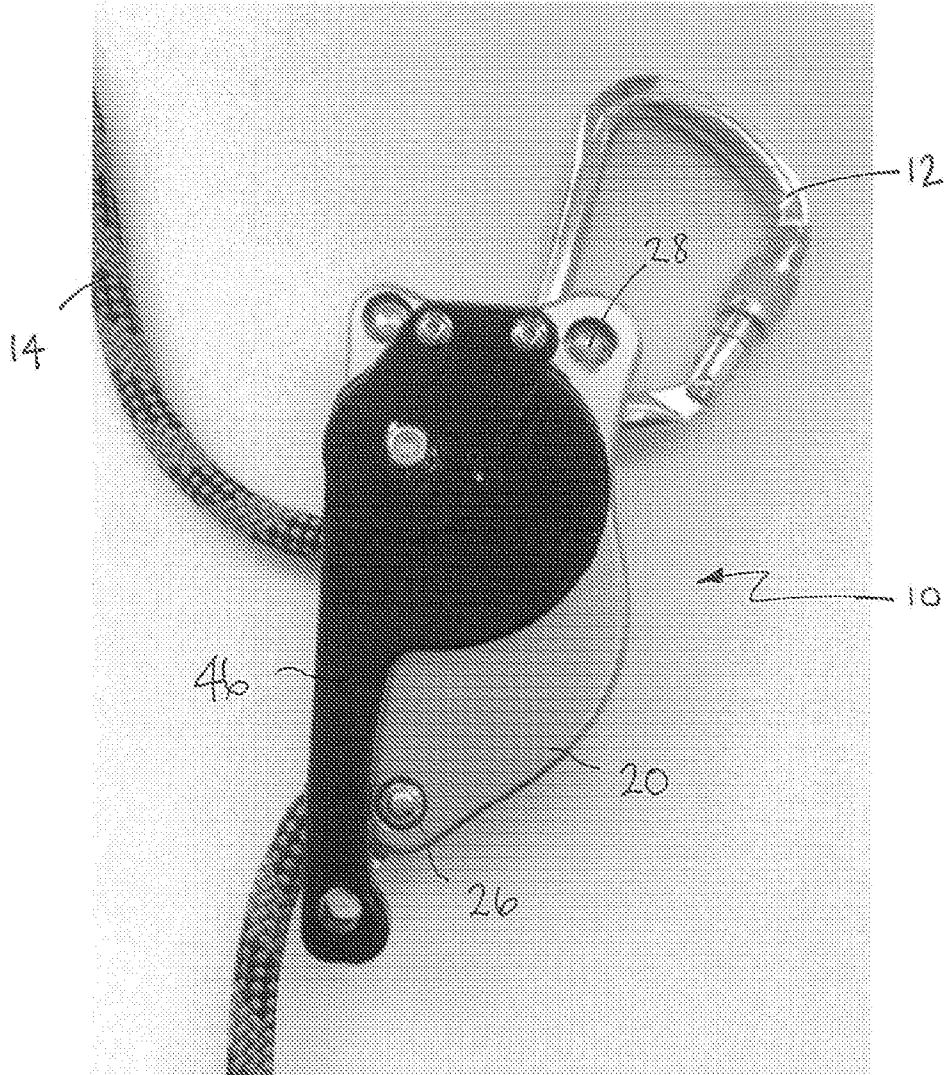

FIG. 2

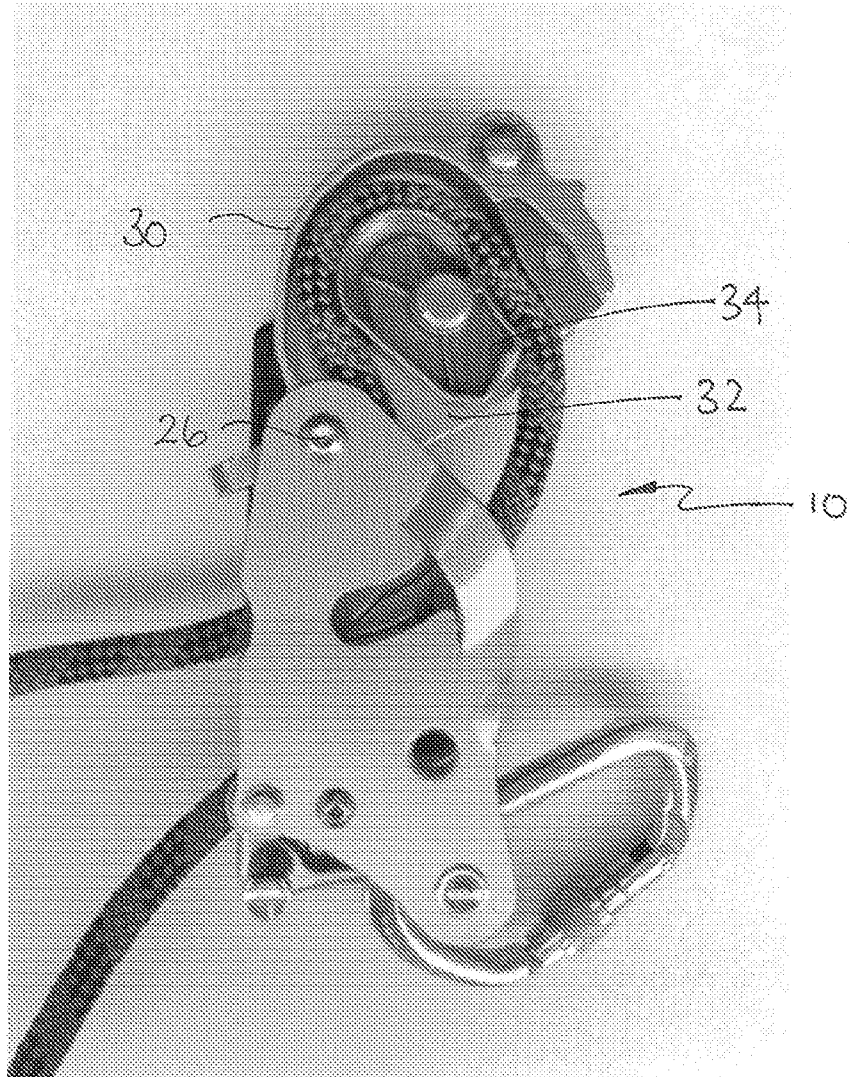

FIG. 3

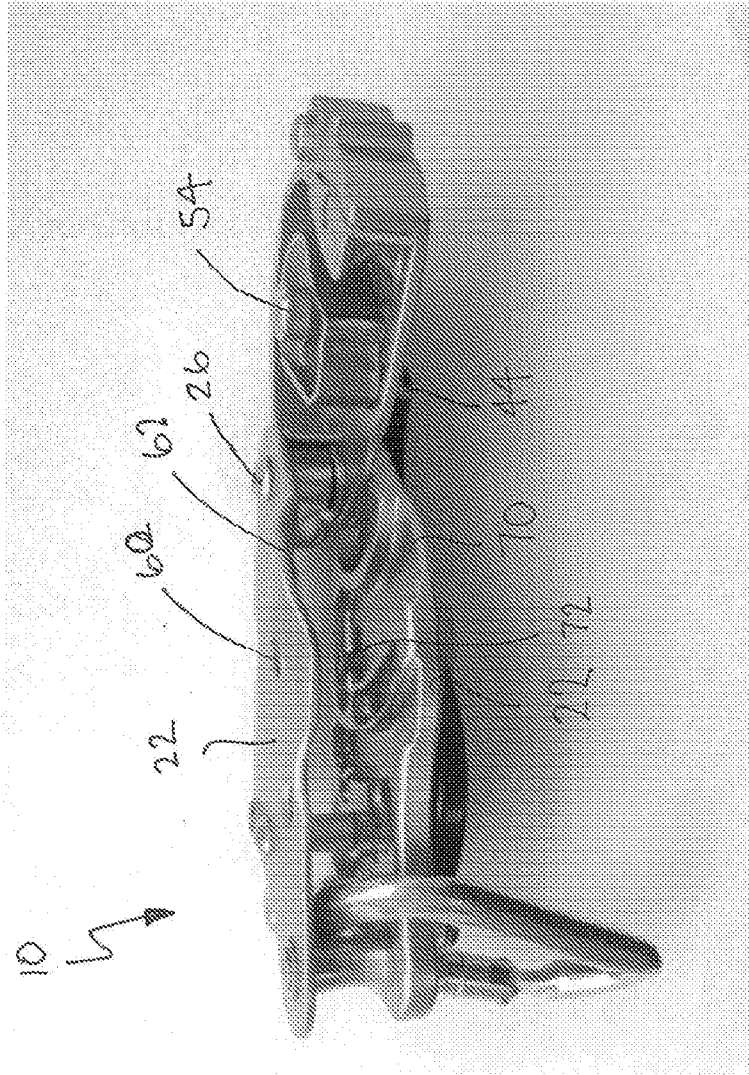

FIG. 4

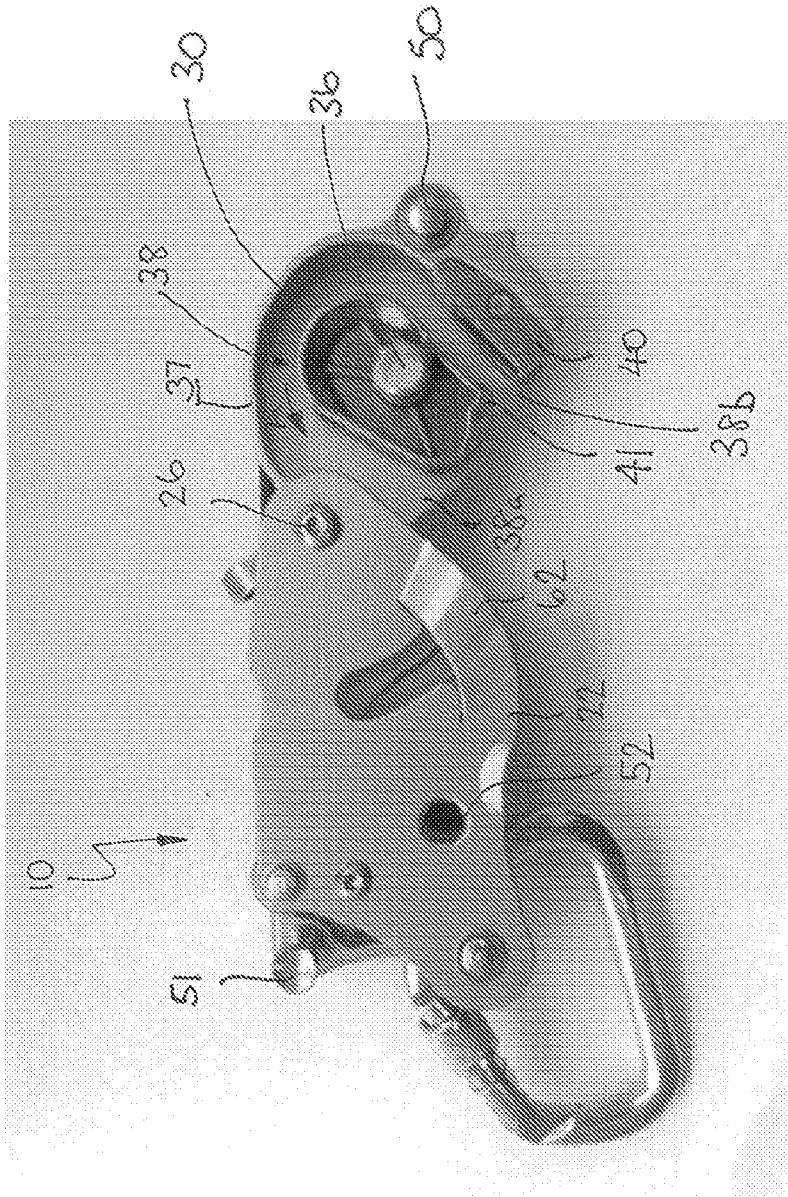

FIG. 5

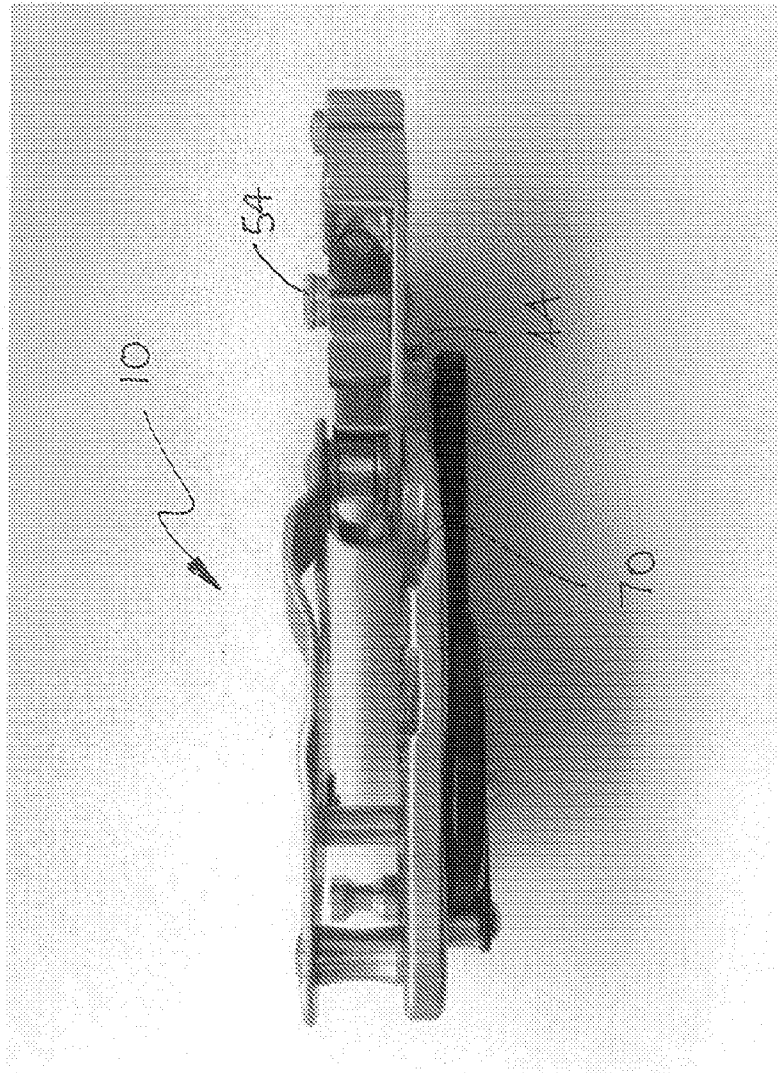

FIG. 6

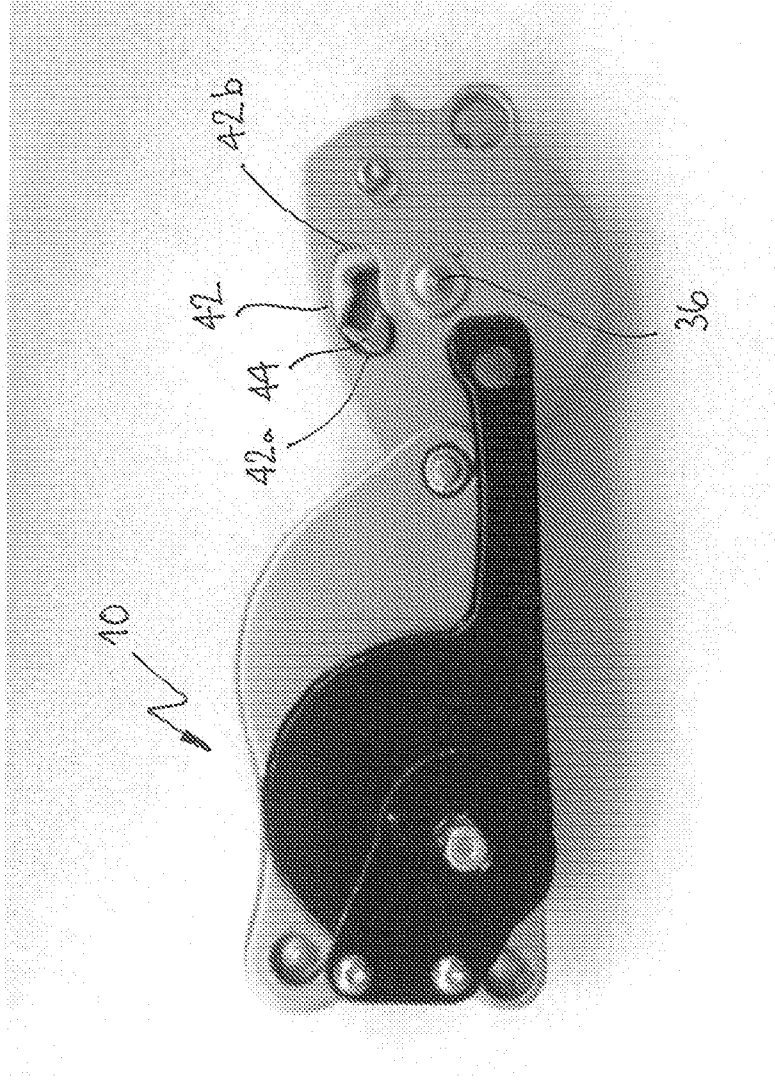
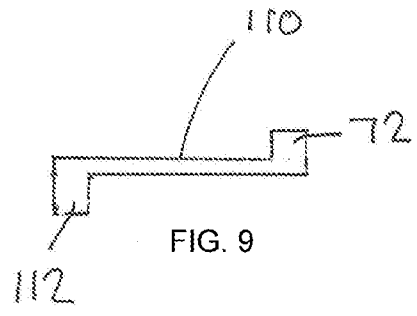
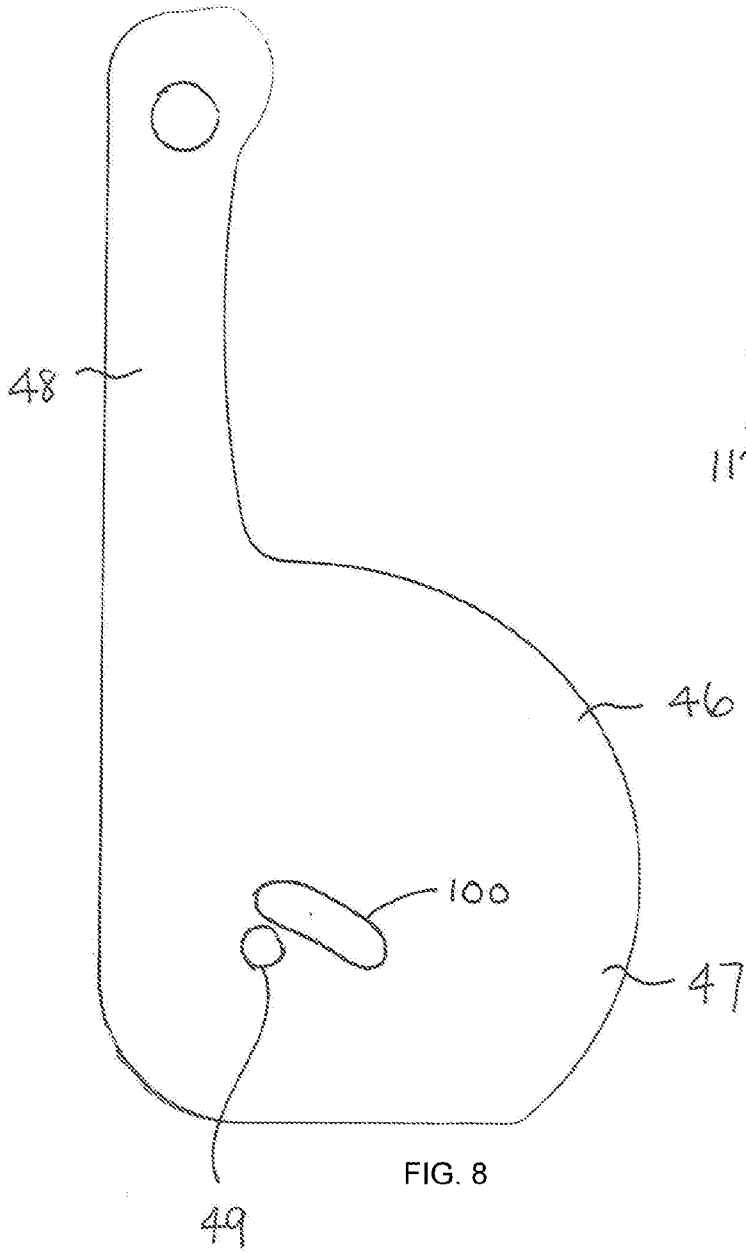

FIG. 7



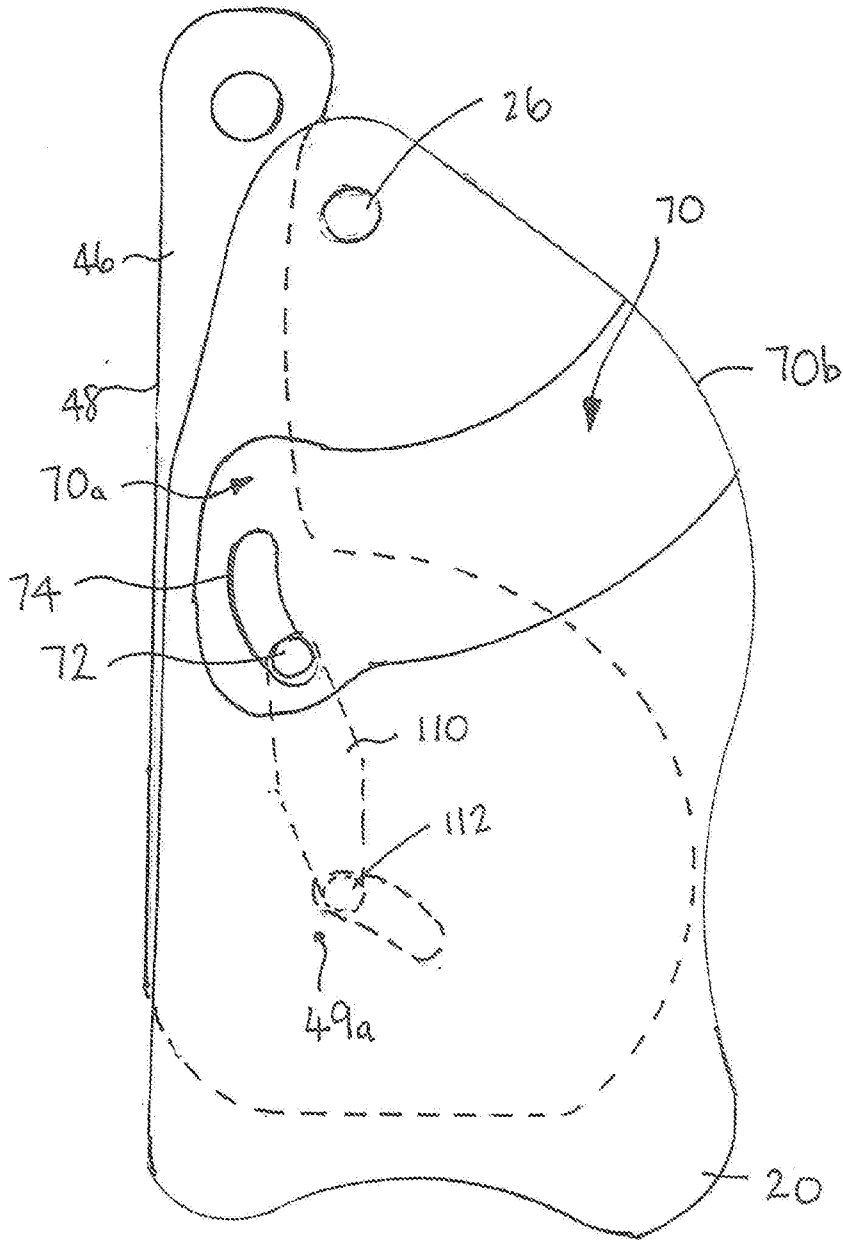

FIG. 10

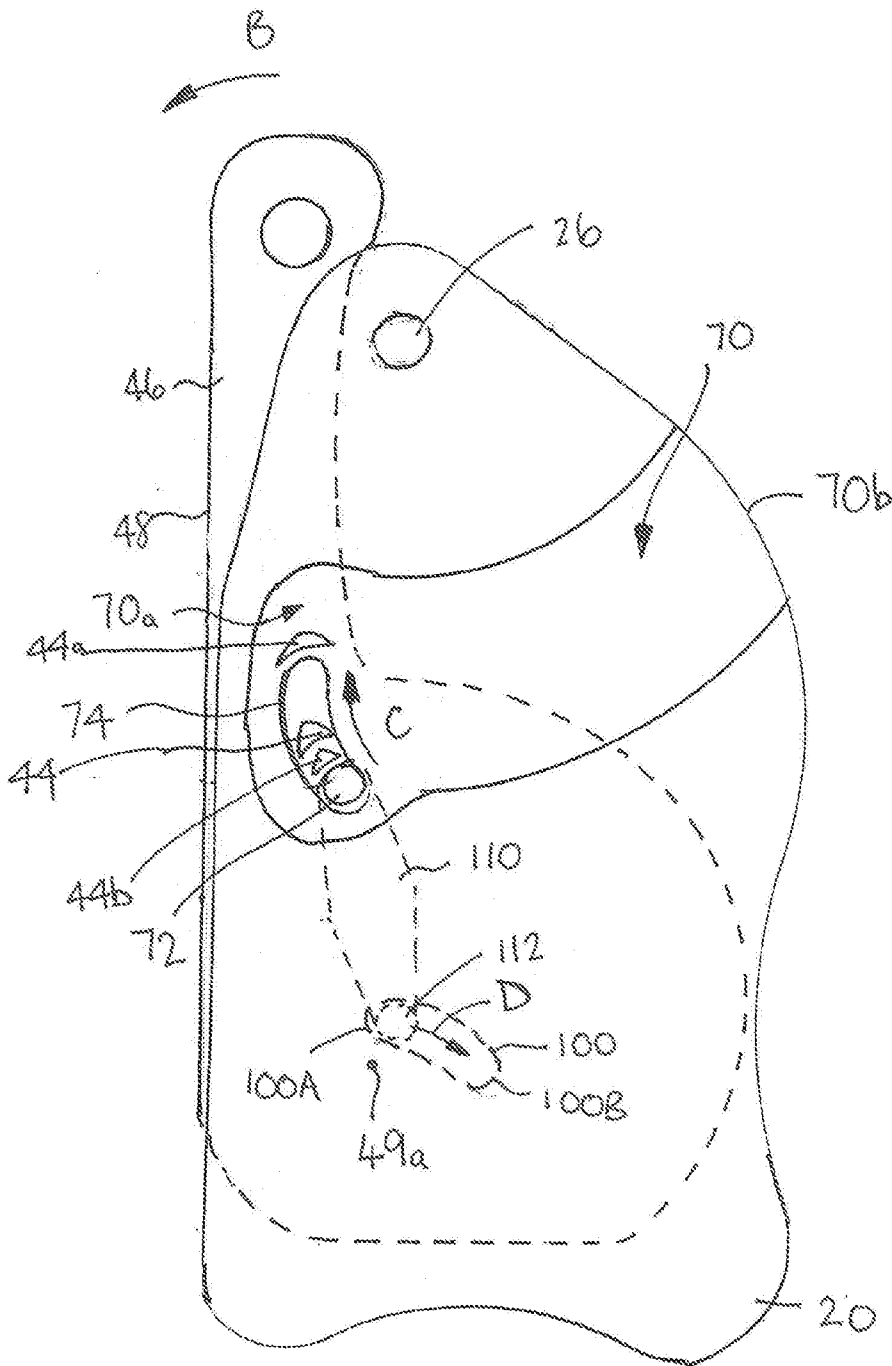

FIG. 11

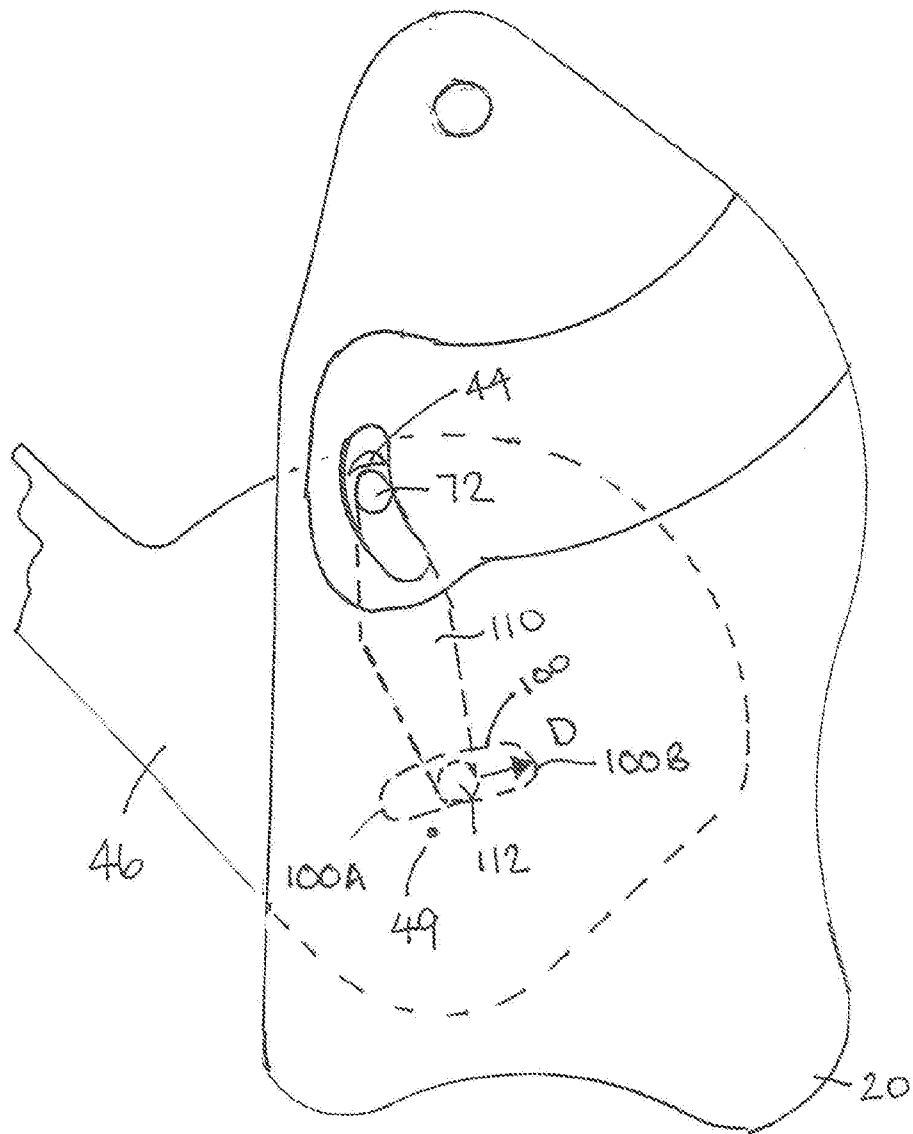

FIG. 12

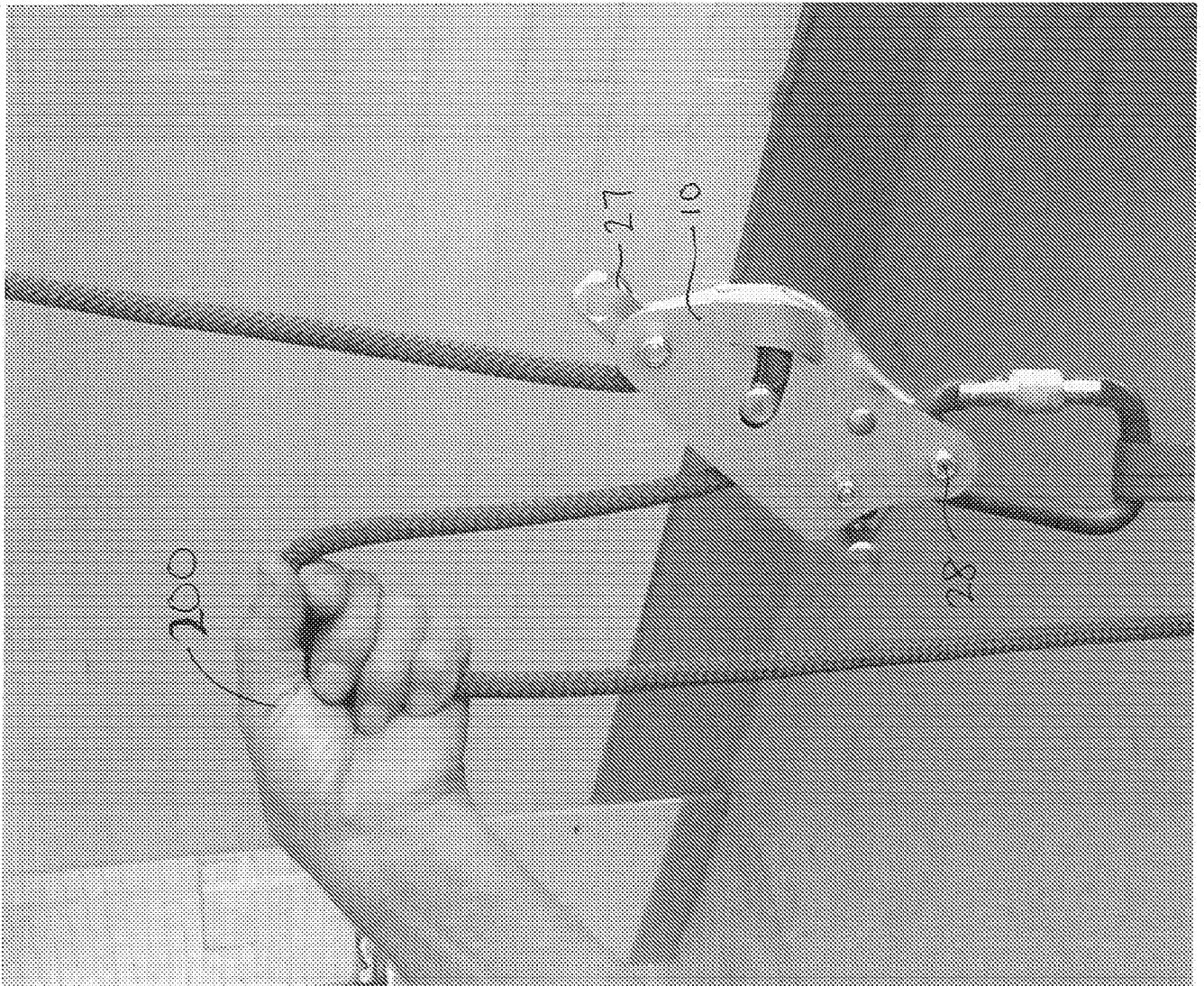

FIG. 13

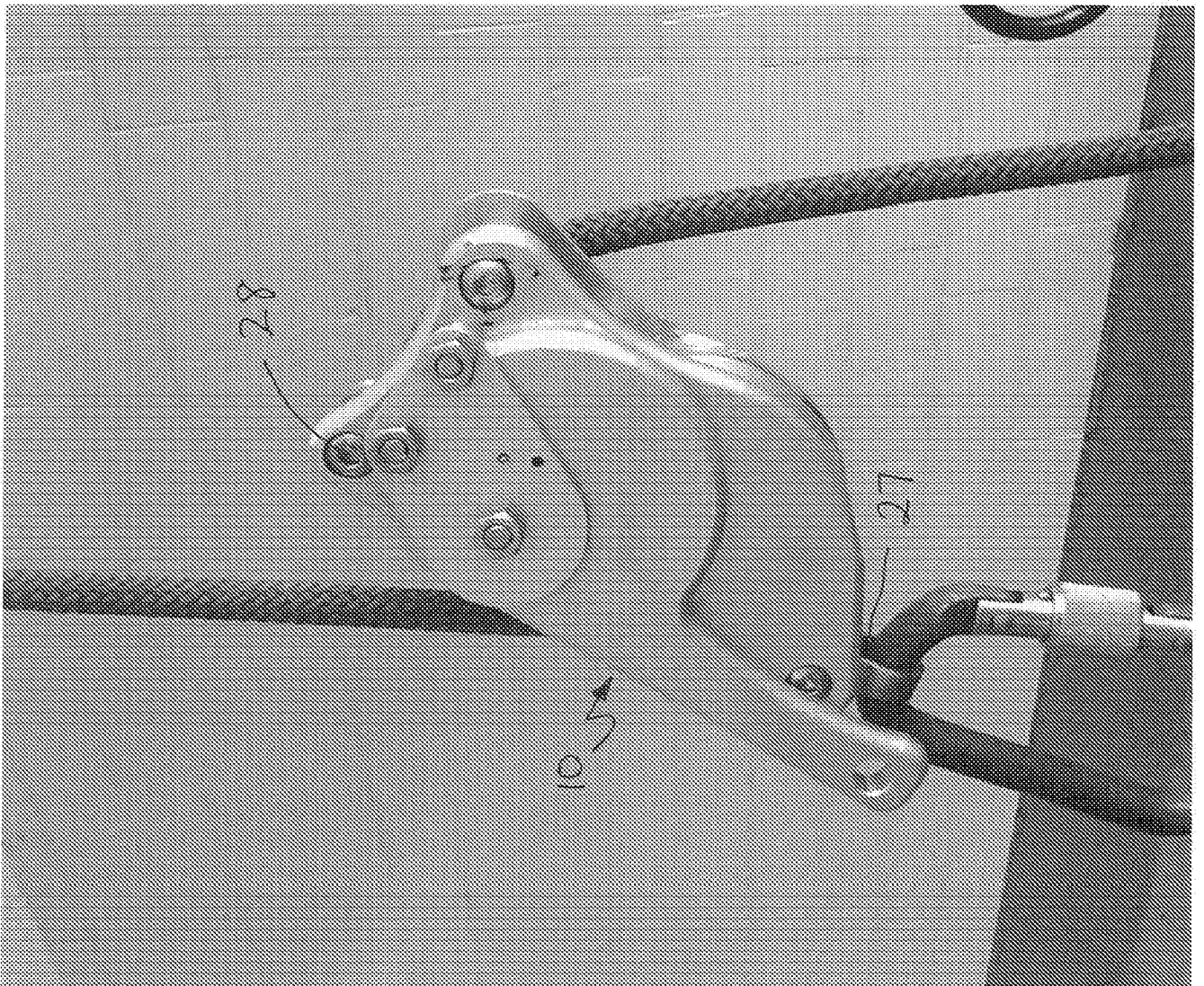

FIG. 14

INTERNATIONAL SEARCH REPORT

International application No.

PCT/AU2016/050090

A. CLASSIFICATION OF SUBJECT MATTER

**A62B 1/14 (2006.01) A63B 29/02 (2006.01) A62B 1/08 (2006.01) A62B 1/18 (2006.01) B66D 3/02 (2006.01)
B66D 3/04 (2006.01)**

According to International Patent Classification (IPC) or to both national classification and IPC

B. FIELDS SEARCHED

Minimum documentation searched (classification system followed by classification symbols)

Documentation searched other than minimum documentation to the extent that such documents are included in the fields searched

Electronic data base consulted during the international search (name of data base and, where practicable, search terms used)

EPODOC, WPIAP: IPC CPC A62B1/14, A62B1/08, A62B1/18, A63B29/02, B66D3/02, B66D3/04, A62B35/0093, F16H55/50 with keywords: descent, descend, belay, abseil, mountaineer, rappel, rotate, revolve, spin, whirl, twirl, swivel guide, sheave, cam, wheel, handle, arm, grip, control, hilt, lever, pinch, squeeze, friction, brake, resistance, drag, grip, pivot, unfold, fold, pulley, hoist, sheath, tray, rope, cable, line, cord and similar terms/combinations.

Google Patents: Keywords as above. **Espacenet:** Keywords as above.**EPOQUE, GOOGLE, AUSPAT & IP Australia Internal Databases:** Applicant and Inventor Search.

C. DOCUMENTS CONSIDERED TO BE RELEVANT

Category*	Citation of document, with indication, where appropriate, of the relevant passages	Relevant to claim No.
	Documents are listed in the continuation of Box C	

 Further documents are listed in the continuation of Box C See patent family annex

* Special categories of cited documents:		
"A" document defining the general state of the art which is not considered to be of particular relevance	"T"	later document published after the international filing date or priority date and not in conflict with the application but cited to understand the principle or theory underlying the invention
"E" earlier application or patent but published on or after the international filing date	"X"	document of particular relevance; the claimed invention cannot be considered novel or cannot be considered to involve an inventive step when the document is taken alone
"L" document which may throw doubts on priority claim(s) or which is cited to establish the publication date of another citation or other special reason (as specified)	"Y"	document of particular relevance; the claimed invention cannot be considered to involve an inventive step when the document is combined with one or more other such documents, such combination being obvious to a person skilled in the art
"O" document referring to an oral disclosure, use, exhibition or other means	"&"	document member of the same patent family
"P" document published prior to the international filing date but later than the priority date claimed		

Date of the actual completion of the international search
8 March 2016

Date of mailing of the international search report
08 March 2016

Name and mailing address of the ISA/AU

AUSTRALIAN PATENT OFFICE
PO BOX 200, WODEN ACT 2606, AUSTRALIA
Email address: pct@ipaustralia.gov.au

Authorised officer

Mukunthan Krishnapillai
AUSTRALIAN PATENT OFFICE
(ISO 9001 Quality Certified Service)
Telephone No. (03) 9935 9601

INTERNATIONAL SEARCH REPORT

International application No.

C (Continuation).

DOCUMENTS CONSIDERED TO BE RELEVANT

PCT/AU2016/050090

Category*	Citation of document, with indication, where appropriate, of the relevant passages	Relevant to claim No.
X	WO 2003/092816 A1 (BORNACK GMBH & CO. KG) 13 November 2003 fig. 1-7.	1-3, 5-11, 13
X	US 5360083 A (HEDE) 01 November 1994 abstract; fig. 1-3.	1, 8-11
X	US 2014/0262611 A1 (ODDOU et al.) 18 September 2014 abstract; fig. 1-4; para. 0024-0027.	1, 8-11
A	US 5054577 A (PETZL et al.) 08 October 1991 fig. 1-6.	

INTERNATIONAL SEARCH REPORT

Information on patent family members

International application No.

PCT/AU2016/050090

This Annex lists known patent family members relating to the patent documents cited in the above-mentioned international search report. The Australian Patent Office is in no way liable for these particulars which are merely given for the purpose of information.

Patent Document/s Cited in Search Report		Patent Family Member/s			
Publication Number	Publication Date	Publication Number	Publication Date		
WO 2003/092816 A1	13 November 2003	WO 03092816 A1	13 Nov 2003		
		DE 10219492 A1	13 Nov 2003		
		EP 1499393 A1	26 Jan 2005		
		EP 1499393 B1	22 Nov 2006		
		US 5360083 A	01 November 1994	US 5360083 A	01 Nov 1994
US 5360083 A	01 November 1994	EP 0593369 A1	20 Apr 1994		
		EP 0593369 B1	18 Dec 1996		
		FR 2696647 A1	15 Apr 1994		
		FR 2696647 B1	25 Nov 1994		
		JP H07551 A	06 Jan 1995		
		JP 3231513 B2	26 Nov 2001		
		US 2014/0262611 A1	18 September 2014	US 2014262611 A1	18 Sep 2014
				EP 2777772 A2	17 Sep 2014
EP 2777773 A2	17 Sep 2014				
US 2014262610 A1	18 Sep 2014				
US 5054577 A	08 October 1991	US 5054577 A	08 Oct 1991		
		AU 622996 B2	30 Apr 1992		
		AU 5288990 A	09 Oct 1990		
		EP 0416079 A1	13 Mar 1991		
		EP 0416079 B1	12 May 1993		
		FR 2644428 A1	21 Sep 1990		
		FR 2644428 B1	29 May 1992		
		JP H03505689 A	12 Dec 1991		
		WO 9010476 A1	20 Sep 1990		

End of Annex

Due to data integration issues this family listing may not include 10 digit Australian applications filed since May 2001.

Form PCT/ISA/210 (Family Annex)(July 2009)