

G. G. FLOYD.
CAR TRUCK BOLSTER.

APPLICATION FILED JUNE 3, 1904.

NO MODEL.

2 SHEETS—SHEET 1.

Fig. 1.

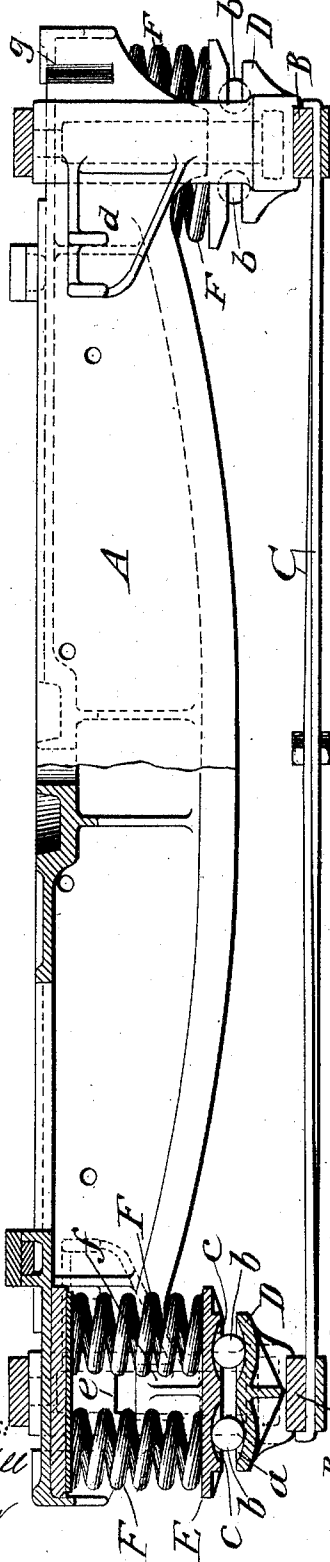
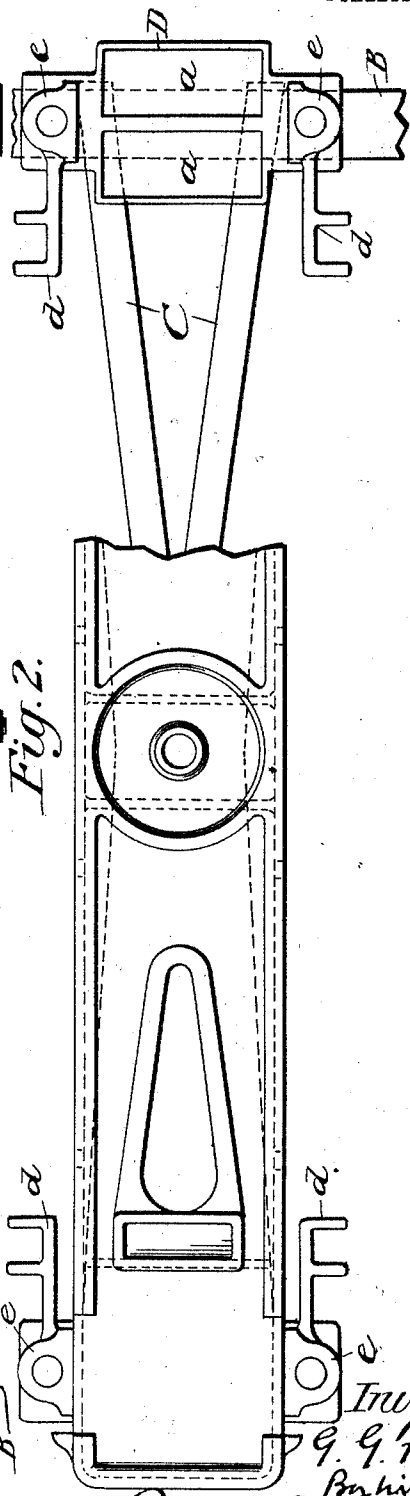

Fig. 2.



Witnesses:
 Chas. O'Neill
 J. M. Mann

Inventor:
 G. G. Floyd
 By his attys.
 Rennie Goodenough

No. 776,899.

PATENTED DEC. 6, 1904.

G. G. FLOYD.
CAR TRUCK BOLSTER.
APPLICATION FILED JUNE 3, 1904.

NO MODEL.

2 SHEETS—SHEET 2.

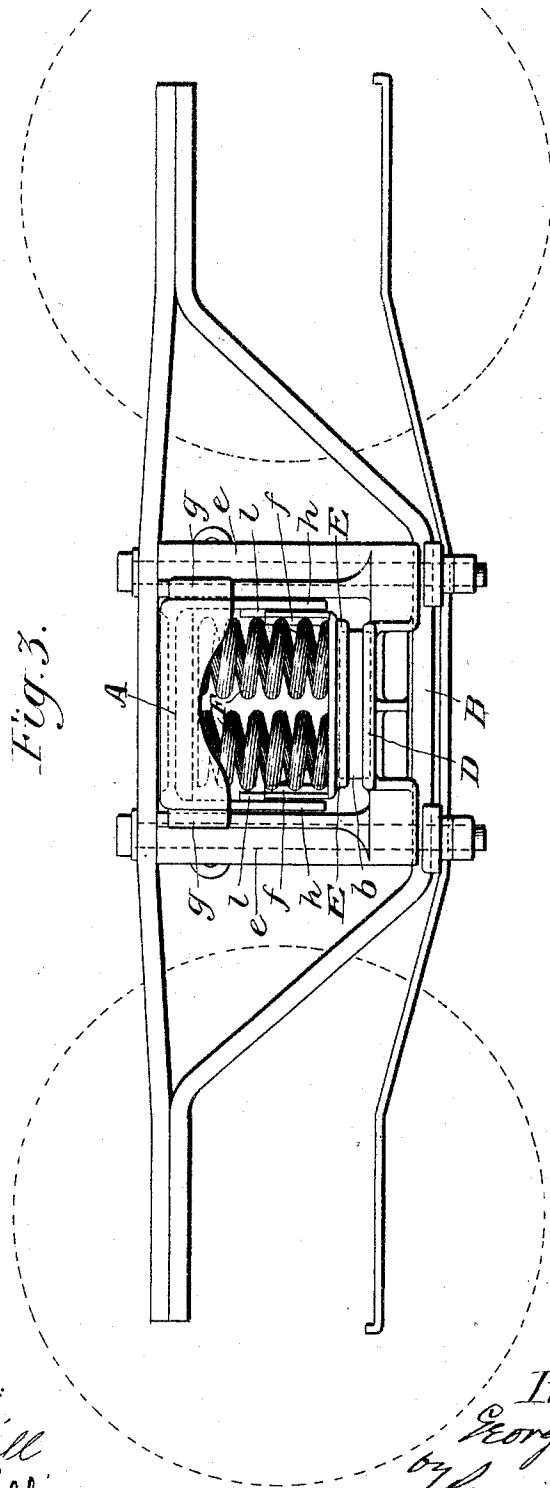

Fig. 3.

Witnesses:
Chas J O'Neill
W Beale Williams,

Inventor:
George G. Floyd,
by *Lucius Alden*,
Attys.

UNITED STATES PATENT OFFICE.

GEORGE G. FLOYD, OF ST. LOUIS, MISSOURI, ASSIGNOR TO AMERICAN STEEL FOUNDRIES, OF ST. LOUIS, MISSOURI, A CORPORATION OF MISSOURI.

CAR-TRUCK BOLSTER.

SPECIFICATION forming part of Letters Patent No. 776,899, dated December 6, 1904.

Application filed June 3, 1904. Serial No. 210,957. (No model.)

To all whom it may concern:

Be it known that I, GEORGE G. FLOYD, a citizen of the United States, residing in the city of St. Louis, State of Missouri, have invented certain new and useful Improvements in Car-Truck Bolsters; and I do hereby declare the following to be a full, clear, and exact description of the invention, such as will enable others skilled in the art to which it appertains to make and use the same.

My invention relates to certain new and useful improvements in car-truck bolsters, and particularly to means for suspending them from the side frames of the truck in such manner as to provide for a limited capacity to move longitudinally upon their supports or bearings.

In the accompanying drawings, Figure 1 represents, partly in section and partly in elevation, a car-truck bolster arranged in accordance with my invention. Fig. 2 represents a top plan view thereof, partly broken away. Fig. 3 is a side elevation of a standard truck, showing the bolster applied thereto.

Similar letters of reference indicate similar parts in the several views.

Referring to the drawings, A indicates a car-truck bolster, and B indicates portions of the side frames connected by the cross-ties C.

In carrying out my invention I provide each of the side frames with a plate D, having pockets *a* for the reception of the rollers *b* and also having column-guides *e*, formed integral therewith, provided with brake-beam hangers *d*. Above the plate D, I locate the plate E, having similar pockets *c*, likewise engaging the rollers, and thus completing the roller-bearing. The plate E supports the springs F and is provided with vertical slides *f*, which engage with corresponding guide-ribs *g*, formed on the inside walls of the bolster near the ends thereof, said walls being extended as depending lugs *h* to accommodate said ribs. The springs F support the ends of the bolster either directly or through the interposition of wear-plates and shims. The column-guides *e*, which lie on opposite sides

of the bolster near the ends thereof, permit the latter to have a limited longitudinal movement before said bolster is arrested by the lugs *g* thereon engages the column-guides.

A characteristic advantage of the structure shown and described is that the desired limited longitudinal play of the bolster is obtained without interfering with the function of the springs F, inasmuch as the roller-bearing, which is formed in one piece with the column-guides, is located below the plate supporting the springs. So far as I am aware this feature is broadly new in truck construction, and I wish to be understood, therefore, as intending to cover it generically.

Having thus described my invention, what I claim is—

1. The combination with the side frames of a car-truck, of a truck-bolster supported thereon through the intermediacy of rollers located in pockets between lower and upper plates, the lower plates being mounted on the side frames and having column-guides formed integral therewith, and the upper ones having springs interposed between them and the ends of the bolster; substantially as described.

2. A car-truck bolster provided at its ends with spring-seats, in combination with springs upon which said seats rest, plates supporting the springs and provided on their under surfaces with pockets, rollers engaging said pockets, and subjacent pocket-plates supported by the side frames and provided with integral column-guides; substantially as described.

3. A car-truck bolster, spring-supported at its ends, with capacity for limited longitudinal movement, roller-bearings interposed between the springs and integral column-guide and bearing-plate castings mounted on the main frame of the truck; substantially as described.

In testimony whereof I affix my signature in presence of two witnesses.

GEORGE G. FLOYD.

Witnesses:

JOHN PORTER,
E. B. SHERZES.