

(19) World Intellectual Property Organization  
International Bureau



(43) International Publication Date  
29 December 2011 (29.12.2011)

(10) International Publication Number  
**WO 2011/161648 A1**

- (51) **International Patent Classification:**  
A47J 27/00 (2006.01) A47J 36/00 (2006.01)
- (21) **International Application Number:**  
PCT/IB2011/052768
- (22) **International Filing Date:**  
24 June 2011 (24.06.2011)
- (25) **Filing Language:** English
- (26) **Publication Language:** English
- (30) **Priority Data:**  
586407 24 June 2010 (24.06.2010) NZ  
589454 23 November 2010 (23.11.2010) NZ
- (71) **Applicant (for all designated States except US):** AGD HOLDINGS LIMITED [NZ/NZ]; C/- Wynyard Wood, Level 15 51-53 Shortland Street, Auckland (NZ).
- (72) **Inventors; and**
- (75) **Inventors/Applicants (for US only):** MOODIE, David [NZ/NZ]; 239 Buckley Road, Island Bay, Wellington (NZ). DALTON, Graham, Robert, Brett [NZ/NZ]; 14 Crescent Road, Parnell, Auckland (NZ).
- (74) **Agents:** BLIJLEVENS, Antonius, P, H et al.; A J Park, 6th Floor Huddart Parker Building, PO Box 949, Wellington, 6015 (NZ).

(81) **Designated States (unless otherwise indicated, for every kind of national protection available):** AE, AG, AL, AM, AO, AT, AU, AZ, BA, BB, BG, BH, BR, BW, BY, BZ, CA, CH, CL, CN, CO, CR, CU, CZ, DE, DK, DM, DO, DZ, EC, EE, EG, ES, FI, GB, GD, GE, GH, GM, GT, HN, HR, HU, ID, IL, IN, IS, JP, KE, KG, KM, KN, KP, KR, KZ, LA, LC, LK, LR, LS, LT, LU, LY, MA, MD, ME, MG, MK, MN, MW, MX, MY, MZ, NA, NG, NI, NO, NZ, OM, PE, PG, PH, PL, PT, RO, RS, RU, SC, SD, SE, SG, SK, SL, SM, ST, SV, SY, TH, TJ, TM, TN, TR, TT, TZ, UA, UG, US, UZ, VC, VN, ZA, ZM, ZW.

(84) **Designated States (unless otherwise indicated, for every kind of regional protection available):** ARIPO (BW, GH, GM, KE, LR, LS, MW, MZ, NA, SD, SL, SZ, TZ, UG, ZM, ZW), Eurasian (AM, AZ, BY, KG, KZ, MD, RU, TJ, TM), European (AL, AT, BE, BG, CH, CY, CZ, DE, DK, EE, ES, FI, FR, GB, GR, HR, HU, IE, IS, IT, LT, LU, LV, MC, MK, MT, NL, NO, PL, PT, RO, RS, SE, SI, SK, SM, TR), OAPI (BF, BJ, CF, CG, CI, CM, GA, GN, GQ, GW, ML, MR, NE, SN, TD, TG).

**Published:**

— with international search report (Art. 21(3))

(54) **Title:** COOKWARE

FIGURE 29

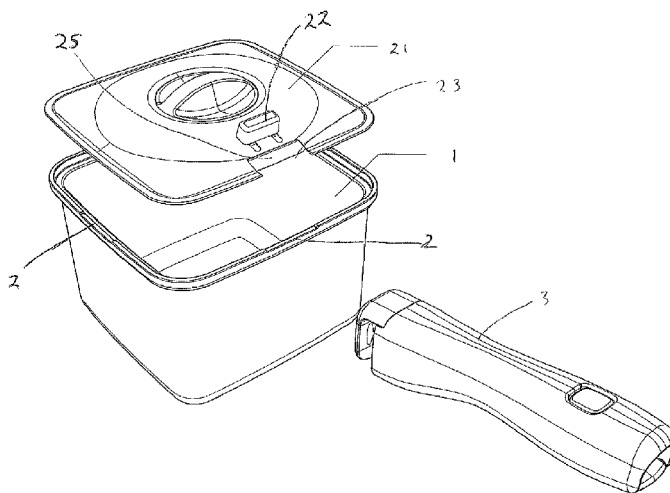

(57) **Abstract:** A cookware assembly or set comprising or including at least one cookware vessel of a substantially square peripheral exterior and interior form when viewed in plan, wherein the vessel has an attachment location on at least one of the four sides, the attachment location being a relief in the vessel's rim suitable for handle engagement, and a handle selectively engageable at the or any one of the attachment locations, the handle with both proximal and distal end regions having a pair of jaw elements at the proximal region for facilitating engagement to an attachment location such that a first jaw of the jaw pair locates substantially inside the vessel and a second jaw of the jaw pair locates substantially outside of the vessel, and a lid able to fit on the cookware vessel and to close, or at least substantially close, the cookware vessel.



WO 2011/161648 A1

## COOKWARE

### FIELD OF THE INVENTION

The present invention relates to cookware. More particularly but not exclusively it  
5 relates to space saving cookware.

### BACKGROUND

Typical cookware items such as pots and pans with fixed handles are sometimes  
large and cumbersome and are difficult to stow efficiently. In some situations, such as in  
10 apartments boats, caravans etc there may be limited space available to store cookware.  
Typical cookware does not lend itself for use in situations in which there is limited space for  
storage.

It is an object of the present invention to provide improved cookware which  
overcomes or at least partially ameliorates some of the abovementioned disadvantages or  
15 which at least provides the public with a useful choice

### BRIEF DESCRIPTION OF THE INVENTION

In a first aspect the present invention consists in a **cookware assembly or set**  
comprising or including:

20 at least one cookware vessel of a substantially square peripheral exterior and interior  
form when viewed in plan, wherein the vessel has an attachment location on at least one of  
the four sides, the attachment location being a relief in the vessel's rim suitable for handle  
engagement, and

a handle selectively engageable at the or any one of said attachment locations, the  
25 handle with both proximal and distal end regions having a pair of jaw elements at the  
proximal region for facilitating engagement to an attachment location such that a first jaw of  
the jaw pair locates substantially inside the vessel and a second jaw of the jaw pair locates  
substantially outside of the vessel, and

a lid able to fit on the cookware vessel and to close, or at least substantially close,  
30 the cookware vessel.

Preferably the cookware vessel is of a form to enable nesting at least in part with a  
like vessel of a smaller or larger size, if not also partially nestable with one of the same size.

Preferably a plurality of like cookware vessels may sequentially nest, one within the  
other in order of their size, for efficient stowage.

Preferably each cookware vessel may sequentially nest, one within the other in order of their size, even with a corresponding lid located on each nested vessel.

5 Preferably each lid has a handle located substantially centrally of the lid body and has a grippable region extending upwardly substantially beyond the lid body, and a hollow region located below the grippable region, wherein the hollow region is dimensioned so that it can receive at least a portion of the grippable region of another like lid placed beneath so as to prevent interference between the lid handle and another lid when a plurality of cookware vessels are sequentially nested with their lids located thereon.

10 Preferably the position of one or both jaws of the jaw pair may be adjusted between a locked condition where the jaws are closer together than a further apart unlocked condition.

Preferably the handle has a lever to cause adjustment of the jaws between the locked and unlocked conditions.

15 Preferably the lever can articulate between at least two stable conditions, one of which positions corresponds to the locked condition of the jaw pair, the other corresponding to the unlocked condition of the jaw pair.

Preferably the articulation of the lever causes a sliding and/or otherwise guided member as a second jaw element to move relative to a more proximal fixed jaw element.

20 Preferably the jaw pair are shaped such that they are complementary with the attachment location to lock the handle to the vessel in a rigid, weight bearing manner.

Preferably the second jaw of the jaw pair engages under the relief feature of the rim.

Preferably the relief in the rim restricts movement of an attached handle along the rim of the vessel.

25 Preferably the lid includes a relief substantially on its periphery to accommodate the handle when such is engaged at an attachment location.

Preferably the lid includes a slideable member able to encroach over the relief to reduce venting during cooking.

Preferably the slideable member can encroach over the relief to such an extent that the lid can substantially seal the vessel to which the lid is associated.

30 In another aspect the present invention consists in a **handle** suitable for attachment to a cookware vessel, the handle comprising or including:

a pair of jaw elements at a proximal region of the handle,

an actuator to adjust the relative position of the pair of jaw elements,

wherein the relative position of the jaw elements facilitates attachment of the handle to an attachment location provided as a relief in the rim of a cookware vessel such that a first jaw of the jaw pair locates substantially inside the vessel and a second jaw of the jaw pair locates substantially outside of the vessel .

5            Preferably the position of one or both jaws of the jaw pair may be adjusted between a locked condition where the jaws are closer together than a further apart, unlocked condition.        Preferably the actuator is a lever to cause adjustment of the jaws between the locked and unlocked conditions.

10            Preferably the lever can articulate between at least two stable conditions, one of which positions corresponds to the locked condition of the jaw pair, the other corresponding to the unlocked condition of the jaw pair.

              Preferably the articulation of the lever causes a sliding and/or otherwise guided member as a second jaw element to move relative to a more proximal fixed jaw element.

15            Preferably the lever has a cam profile that engages the sliding member        , the arrangement being such that, via articulation of the lever, the cam profile can be pivoted outwardly from a condition that stably holds the sliding member in a locked condition closer to the first mentioned jaw yet allows the retreat of the sliding member to an unlocked condition under the action of a bias when the cam is moved or urged away from that condition.

20            Preferably the sliding member is biased towards the cam profile of the lever.

              Preferably the jaw pair are shaped such that they are complementary with the attachment location of the cookware vessel to lock the handle to the vessel in a rigid, weight bearing manner.

25            In another aspect the present invention consists in a **lid** for, or suitable for, a cookware vessel of a substantially square or rectangular peripheral exterior and interior form when viewed in plan, save optionally for rounded transitions between the adjacent sides, said lid being an assembly defining

30            a lid body having a relief on its periphery that accords to a centre of a side of such a cookware vessel,

              a slide or other moveable member carried by the lid body able to close the relief, and

              a handle feature of the lid carried by the lid body.

              Preferably the handle is located substantially centrally of the lid body and has a grippable region extending upwardly substantially beyond the lid body, and a hollow region

located below the grippable region, wherein the hollow region is dimensioned so that it can receive at least a portion of the grippable region of another like lid placed beneath so as to prevent interference between the lid handle and another lid when a plurality of cookware vessels are sequentially nested with their lids located thereon.

5            Preferably the slideable member can encroach over the relief to such an extent that the lid can substantially seal a vessel to which the lid is associated.

              In another aspect the present invention consists in a **cookware vessel** that includes at least one handle attachment location defined on the rim of the vessel, the handle attachment location being suitable for selective attachment of a handle, **wherein** the handle  
10            attachment location is recessed from the surrounding rim to restrict movement of an attached handle along the rim of the vessel.

              Preferably the cookware vessel is of a form to enable nesting at least in part with a like vessel of a smaller or larger size, if not also partially nestable with one of the same size.

              Preferably a plurality of like cookware vessels may sequentially nest, one within the  
15            other in order of their size, even with a corresponding lid located on each vessel.

              In another aspect the present invention consists in a **cookware assembly or set** comprising two or more cookware vessels and lids corresponding to each cookware vessel, **wherein** each lidded cookware vessel is sequentially nested, or may sequentially  
20            nest, one within the other, or another, in order of their size in an efficient manner.

              Preferably a handle engageable to either, or any, of the vessels is located in  
20            the smaller or smallest vessel.

              In a another aspect aspect the present invention is, **in combination or as a set**, at least one cookware vessel of a substantially square peripheral exterior and interior form when viewed in plan, optionally and preferably having rounded transitions between the  
25            adjacent sides, and of a form nestable at least in part with a like vessel of a smaller or larger size, if not also partially nestable with one of the same size, and wherein the vessel has a attachment location for handle engagement on at least two of the four sides, and

              a handle selectively engageable at any one of said attachment locations by placing a jaw of its jaw pair inside the vessel and the complementary jaw outside of the vessel thereby  
30            to cantilever or otherwise carry the vessel's weight, or at least part of its weight, from the handle.

              Preferably the jaws of the jaw pair are moveable in a longitudinal direction with respect to one another to facilitate attachment and locking of the handle to the vessel.

Preferably the jaws of the jaw pair are shaped such that they are complementary with the attachment location to lock the handle to the vessel in a rigid, weight bearing manner.

5 Preferably the more outward of the jaws of the jaw pairs is latched and/or biased to keep a shoulder (or equivalent) under a lip or other feature of the location zone outwardly of the vessel which presents a co-acting shoulder (or equivalent) in the other direction.

Preferably the location is provided by a set down from the side.

In another aspect the invention consists in, **in combination, as a subassembly or as an assembly,**

10 at least one cookware vessel of substantially square or rectangular peripheral exterior and corresponding interior form when viewed in plan, optionally having rounded transitions between the adjacent sides, and of a form having at least one side provided with a relief in a rim feature in order to accommodate a complementary handle feature,

15 a lid able to fit on the cookware vessel and to close, or at least substantially close, the cookware vessel, and

a handle selectively engageable to the cookware vessel at the region of said rim relief but at least in part intrusively of part of the general envelope of the lid, or the vessel to be lidded, when viewed in plan.

20 Preferably the lid includes a moveable member able to cover the gap from the general envelope of the lid in plan to an extent necessary to close any vent opening between either or both (i) the lid body proper and any inserted handle or (ii) the lid body proper and the relief in said rim feature, or (iii) both.

25 Preferably said relief in the rim feature of at least one side is repeated on at least one other side but there is substantial sealing of at least one such relief feature past the lever.

Preferably the relief is of a form herein depicted.

Preferably the cookware has, as its rim, a form defining an outward downwardly facing shoulder below a peripheral upper plateau (save for the zones lowered to provide for optional handle location), and an inwardly facing surface from the peripheral upper plateau down to an upwardly facing ledge on which a lid can or is to (directly or indirectly) seat.

30 In another aspect the present invention may broadly consist in a **cookware vessel** that includes at least one handle attachment zone defined on the rim of the vessel, the handle attachment zone being suitable for selective attachment of a handle, **wherein** the handle attachment zone is recessed from the surrounding rim to restrict movement of an attached handle along the rim of the vessel.

Preferably the vessel is suitable for the attachment of handles of a type that include:  
a knob at one end of the handle body,  
a tongue member extending from the handle body at the same end as the knob to  
define a slot between the tongue member and the knob,

5 wherein the relative position of the tongue member and the knob facilitates  
attachment of the handle to the attachment zone of the cookware vessel.

Preferably the handle attachment zone is suitable to be received in the slot of a  
handle.

Preferably a handle attachment zone is positioned on each side of the vessel.

10 Preferably, when attached to a said handle, at least some of the weight of the vessel  
is cantilevered from the handle due to the attachment of the handle and the vessel.

Preferably the knob and tongue are shaped such that they are complementary with  
the attachment zone to lock the handle to the vessel in a rigid, weight bearing manner.

15 Preferably said cookware vessel is of a shape such that it can efficiently nest with  
like cookware vessels when no handles are attached thereto.

Preferably the vessel is manufactured from one of the following combination of  
materials:

- stainless steel exterior (magnetized for induction), copper or aluminium inside  
and a stainless steel interior, or
- 20 • stainless steel with an aluminium base (disk) stamped on, or
- anodised aluminium exterior and stainless steel interior.

Preferably the vessel is Teflon coated.

In another aspect the invention consists in **a lid for, or suitable for, a cookware  
vessel** having a general envelope to contact (directly or indirectly) that accords to a  
25 cookware vessel of substantially square or rectangular peripheral exterior and interior form  
when viewed in plan, save optionally for rounded transitions between the adjacent sides, said  
lid being an assembly defining

a lid body having a relief from one perimeter of its envelope that accords to a  
centre of a side of such a cookware vessel,

30 a slide or other moveable member carried by the lid body able to close the relief  
from the general envelope of the lid, and

a handle feature of the lid carried by the lid body.

Preferably the lid is of a form as hereinafter described.

In a further aspect the invention consists in a **handle** suitable for attachment to a cookware vessel, said handle being of the form substantially as hereinafter described with or without reference to any one, some or all of the accompanying drawings.

5 In yet a further aspect the invention consists in a **handle** suitable for attachment to a cookware vessel, the handle having an articulating member biased by a bias means whereby it can assume at least two stable conditions, one of which positions holds a sliding and/or otherwise guided member as a second jaw element in closer proximity to a more distal fixed jaw element.

Preferably the arrangement is substantially as hereinafter described.

10 In still a further aspect the invention consists in a **handle assembly** comprising or including

two handle components to define a handle housing and a distal jaw component (whether present in both of them or only one of them),

15 a slide able to reciprocate as a complementary jaw component for said distal jaw, a cam member pivoted from the housing, and

means to bias the slide towards the cam member, the arrangement being such that the cam member can be pivoted outwardly from a condition that stably holds the slide in a utensil gripping position more proximate to the first mentioned jaw yet allows the retreat of the slide under the action of the bias when the cam is moved or urged away from that  
20 condition.

In another aspect the present invention consists in a **handle suitable for attachment to a cookware vessel**, the handle comprising or including:

25 a knob at one end of the handle body, a tongue member extending from the handle body at the same end as the knob to define a slot between the tongue member and the knob,

wherein the relative position of the tongue member and the knob facilitates attachment of the handle to an attachment zone of a cookware vessel.

Preferably the relative position of the tongue and the knob can be adjusted to lock and unlock the handle to a cookware vessel.

30 Preferably adjustment of the tongue with respect to the knob is in the longitudinal direction relative to the handle body.

Preferably positioning of the tongue with respect to the knob is biased but manipulatable by user input.

Preferably the rim of a cookware vessel can be received in the slot to attach the handle to the vessel.

Preferably a complementary attachment zone of the rim of a cookware vessel is received by the slot.

5 In another aspect the present invention consists in **a lid for a cookware vessel**, the lid including a removable band that can be positioned about its perimeter, wherein the band can be fitted to the lid in order to create an airtight seal when the lid is positioned in or onto a complementary cookware vessel.

10 Preferably the band is removed whilst the cookware vessel is used for cooking, and fitted while the cookware vessel is used for storing food.

Preferably the band is silicone rubber.

Preferably the band, when fitted, covers an air vent in the lid.

In another aspect the present invention consists in a cookware vessel substantially as herein described with reference to any one or more of the accompanying drawings.

15 In another aspect the present invention consists in a handle suitable for a cookware vessel substantially as herein described with reference to any one or more of the accompanying drawings.

20 In another aspect the present invention consists in **a lid** for a cookware vessel substantially as herein described with reference to any one or more of the accompanying drawings.

Other aspects of the invention may become apparent from the following description which is given by way of example only and with reference to the accompanying drawings.

As used herein the term “and/or” means “and” or “or”, or both.

25 As used herein “(s)” following a noun means the plural and/or singular forms of the noun.

30 As used in this specification the term “square” when used to describe cookware vessels should be interpreted as meaning substantially square. It may include other quadrilateral forms such as rectangular forms and may include forms that have rounded edges between adjacent sides.

The term “comprising” as used in this specification means “consisting at least in part of”. When interpreting statements in this specification which include that term, the features, prefaced by that term in each statement, all need to be present but other features

can also be present. Related terms such as “comprise” and “comprised” are to be interpreted in the same manner.

The entire disclosures of all applications, patents and publications, cited above and below, if any, are hereby incorporated by reference.

5 This invention may also be said broadly to consist in the parts, elements and features referred to or indicated in the specification of the application, individually or collectively, and any or all combinations of any two or more of said parts, elements or features, and where specific integers are mentioned herein which have known equivalents in the art to which this invention relates, such known equivalents are deemed to be  
10 incorporated herein as if individually set forth.

### **BRIEF DESCRIPTION OF THE DRAWINGS**

The invention will now be described by way of example only and with reference to the drawings in which:

15 **Figure 1** shows a cookware vessel with a handle attached,  
**Figure 2** shows an alternative cookware vessel with a handle attached,  
**Figure 3** shows a plan view of the vessel of figure 1, and shows the location of the cross section A-A,  
**Figure 4** shows a side view of the vessel of figure 1,  
20 **Figure 5** shows a cross section view through A-A of the vessel of figure 1,  
**Figure 6** shows a perspective view of the vessel of figure 1,  
**Figure 7** shows a plan view of the vessel of figure 2, and shows the location of the cross section B-B,  
**Figure 8** shows a front view of the vessel of figure 2,  
25 **Figure 9** shows a side view of the vessel of figure 2,  
**Figure 10** shows a cross section view through B-B of the vessel of figure 1,  
**Figure 11** shows a perspective view of the vessel of figure 1,  
**Figure 12** shows a top view of a handle suitable for a cookware vessel 1,  
**Figure 13** shows a front view of the handle of figure 12,  
30 **Figure 14** shows a side view of the handle of figure 12,  
**Figure 15** shows a perspective view of the handle of figure 12  
**Figure 16** shows a lid for a vessel with a removable band around its perimeter, and  
**Figure 17** shows the removable band for use with the lid of figure 16.

**Figure 18** is an exploded view of yet a different embodiment of handle, one requiring a bias and an over centre capability for a cam acting also as a lever,

**Figure 19** is a side elevation view of a handle assembled from the components as in figure 18 when viewed in side elevation,

5 **Figure 20** is a view of the handle of figure 19 when viewed in perspective from below,

**Figure 21** is a view from below of the handle of figures 19 and 20,

**Figure 22** is an end view of the handle of figures 19 to 21,

10 **Figure 22A and Figure 22B** show a handle substantially of the construction as in figures 18 to 21 (in the case of figure 22A) in its dipping condition, and (in the case of figure 22B) in its levered open condition (the spring not being shown) which allows the biased retreat of the secondary jaw member to act as a jaw or as a jaw-like insertion under a shoulder of the vessel,

15 **Figure 23** is a set of cookware in accordance with the present invention having a lidding feature and showing two handles more or less as depicted in the preceding drawings fitted to two of the cookware items,

**Figure 24** is an enlarged view of one of the assemblies of figure 23, and

20 **Figure 25** shows a series of drawings of a lid showing the components thereof which allow a vent closing feature to be moved back and forth from a fully or near fully open or withdrawn condition to the perimeter of the general envelope of the lid (where it closes any venting) in order to vent and/or allow the fitment and/or retention (or the removal) of a handle and/or prevent venting.

**Figure 26A** shows an alternative handle assembly shown in the locked condition,

**Figure 26B** shows the handle assembly of 26A shown in the unlocked condition,

25 **Figure 27** shows an exploded view of the handle of figure 26A and 26B,

**Figure 28** shows a view of the handle of figure 27,

**Figure 29** shows an assembly view of a cookware vessel and an associated handle and lid,

30 **Figure 30** shows a plurality of like lidded cookware vessels nesting for efficient stowage, and

**Figure 31** shows a plurality of like lidded cookware vessels nesting for efficient stowage with a handle located inside the innermost cookware vessel.

## DETAILED DESCRIPTION OF THE INVENTION

With reference to Figure 1 there is shown a cookware vessel 1 of the present invention. The vessel 1 may be of a shape such that it can easily nest with other, like vessels 1. This will enable the efficient storage of a set of vessels 1 which may be particularly important in situations where storage space is at a premium such as in apartments, boats, caravans etc. In the preferred embodiment the vessel 1 is of a generally square plan shape with rounded corners as shown in Figure 1.

The cookware vessel 1 may be manufactured from any suitable material or combination of materials. Possible combinations of materials are outlined below:

- stainless steel exterior (magnetized for induction), copper or aluminium inside and a stainless steel interior, or
- stainless steel with an aluminium base (disk) stamped on, or
- anodised aluminium exterior and stainless steel interior.

It should be appreciated that other combinations of materials may also be used. The cookware vessel 1 may or may not include a coating layer such as Teflon or similar. The cookware vessel 1 may or may not be suitable for induction cooking.

The cookware vessel 1 includes at least one handle attachment location 2 which may be an indent in the rim of the vessel 1. Preferably there are four handle attachment locations 2 which are located centrally of each side of the vessel 1. The handle attachment locations 2 are suitable for removable attachment of the handle 3.

When the vessel 1 is not in use, it may be stored in an efficient manner with other, like vessels 1 by removing the handle 3 from the attachment location and nesting the vessel 1 with the other like vessels 1. The complementary shape of the other, like vessels 1 enables the nesting.

Figure 2 shows an alternatively shaped vessel 1 which may be used as a frying pan for example. The vessel 1 of Figure 2 only differs in its shape, it may be manufactured from the same materials and may also include four handle attachment locations 2.

Figures 3 to 6 show different views of an exemplary cookware vessel 1 of Figure 1 without the handle 3 attached to an attachment location 2.

Figures 7 to 11 show different views of an exemplary vessel 1 (i.e. a frying pan) of Figure 2 without the handle 3 attached to an attachment location 2.

The handle 3 is shown in more detail in Figures 12 to 15. The handle 3 may include a die cast tongue 4 and knob 5. The tongue 4 and knob 5 are positioned relative to one another in a way to facilitate attachment of the handle 3 to an attachment location 2 of a vessel 1. When the handle 3 is attached to the attachment location 2 it is not able to slide

along the rim 6 of the vessel 1, this is due to the attachment location 2 being recessed slightly from the rim 6 that surrounds it.

The tongue 4 may be moveable with respect to the knob 5 to allow for attachment to the attachment location 2. Once positioned on the attachment location, relative movement between the tongue 4 and the knob 5 may allow for locking of the handle to the vessel 1.

With reference to Figure 16 there is shown a lid 7 suitable for use with a vessel 1. The lid may include a band 8 which may be placed around the edge of the lid 7. The band 8 may be silicone or another similar material and helps create a seal with the vessel 1. Sealing the vessel 1 may be particularly important for creating an air tight environment for storing food inside the vessel 1.

The lid 7 may be stainless steel or other suitable material and may include a vent 9, which allows for the venting of gases from the vessel 1 during cooking (i.e. when the band 8 is not located on the lid 7). The band 8 covers the lid vent 9 when it is located on the lid 7.

The lid 7 may also include a handle 10.

The banded lid can be used to cover the vessel during cooling and refrigeration thereby to ensure a partial vacuum can develop above the vessel contained foodstuff.

An alternative embodiment of the handle of the present invention will now be described with reference to Figures 18 to 22B.

Figure 18 shows complementary and preferably mirror imaged components however able to be held together to define by preferably a region 12 of each a proximal jaw.

Each of the components 11 when held together in the assembled form such as shown by any suitable screws or other means is adapted to guidably locate a slide 13 and a cam lever 14 to be located by its pivot 15 with a pin 16 from regions such as 17 from each of the components 11. Springs 18 are to act on formations 19 of the slide at one end and on the pin 16 at the other end.

The nose region 20 of the lever is a transition point between two substantially stable conditions for the over centred spring action between the lever and the slide 13 such that when in the condition as shown in Figure 22A there is stability that accords with gripping of a cookware component and there is no tendency for the lever to fall away and such that when in the condition as shown in Figure 22B (the springs not being shown for ease of depiction) is stable in a condition able to be disengaged from a cookware vessel or to be inserted into such cookware vessel.

Figures 23 and 24 show that the vessel 1, even when lidded, can be used in a vented or non-vented manner by a lid assembly.

Figures 25 show a lid assembly in accordance with the present invention where a lid assembly 21 has a slide (eg. of plastics material or a metal) actuatable under the knob member 22 to encroach over the scalloped away region which is a relief 23 of the lid body proper 24 so as to reduce venting between the region of the handle (in that case departing somewhat from that previously described). As can be seen the knob 22 can be used to move the associated slide 25 from a condition that does not encroach upon the relief 23 to a position as in to the right in Figure 25 where the whole of the relief 23 has been sealed by part of the slide 25.

In an alternative, preferred embodiment of the handle 3 a single spring 30 may be provided internally of the slidable member 13 to bias the slideably member towards the nose region 20 of the lever 14. Figure 26A corresponds with a locked condition in which the jaw pair 12 and 13 are closer together. Figure 26B corresponds with an unlocked condition in which the jaw pair 12 and 13 are further apart.

The lever 14 is articulatable between two stable conditions, corresponding to the locked and unlocked conditions of the jaw pair 12 and 13. A cam profile exists adjacent the nose region 20 of the lever 14 such that as the lever 14 pivots between its two stable conditions the position of the slide 13 is adjusted. The slide 13 on which the cam profile acts can be caused to slide, against the bias of the spring 30, to the locked condition of Figure 26A, and can be biased to the unlocked condition of 26 B when the cam profile of the nose region moves to position shown in Figure 26B.

A lever release button 31 may be provided to cause the lever 13 to pivot. Alternatively, the lever may be pushed down at its end region 32 to cause the pivoting.

A sleeve 33 may be provided on the inside of the fixed jaw 12 along with inserts 34 that may be provided on the end of the sliding member 13. The sleeve 33 and inserts 34 will engage with the vessel 1 when a handle is used to grip a vessel 1 and is in the locked condition. The sleeve and inserts may be made of silicon or any other suitable material.

With reference to Figure 27 an exploded view of the preferred handle assembly is shown. The various parts and preferred materials for those parts are listed below:

3- handle body (nylon).

14- lever (nylon).

20- nose region (stainless steel).

13- sliding member of the jaw pair (stainless steel).

12- fixed jaw (stainless steel).

31- lever release button 31 (stainless steel)

33- fixed jaw sleeve (silicon)

34- sliding member inserts (silicon)

5 It should be appreciated that the handle 3 may be assembled in a different manner and from different components as shown with reference to Figure 27. It should also be appreciated that the materials of the components may differ from what is listed above, as would be apparent to a person skilled in the art.

Figure 28 shows the preferred handle 3 fully assembled.

10 Persons skilled in the art will appreciate how handle assemblies for example as shown in Figure 28 can be engaged to the attachment location 2 of cookware vessels.

Figure 29 shows a cookware vessel 1 with an associated handle 3 and lid assembly 21. It should be appreciated that the handle 3 is suitable for attachment to any of the attachment locations 2 of the cookware vessel and indeed any attachment location 2 of a like  
15 cookware vessel irrespective of its size. Once a handle is located on a cookware vessel 1, the associated lid 21 may be placed onto the vessel such that the relief 23 corresponds with the attachment location 2 where the handle is located. The knob 22 can then be used to adjust the slide 25 depending on the amount of venting that is desired.

When no handle is attached to a cookware vessel, the slide 25 of a lid 21 can be  
20 adjusted to substantially close the relief 23. Such a lid 21 can then be placed on a corresponding vessel to substantially seal the vessel.

With reference to Figures 30 and 31 it is evident that the cookware vessels, lid assembly 21 and handle of the present invention allow for efficient nesting of the various components. The cookware vessels 1 may sequentially nest, in order of their size, for  
25 efficient stowage. Even with their associated lid 21 located thereon, the lidded vessels can nest efficiently as shown in Figure 30 and 31.

To enable efficient lidded nesting of the cookware vessels, the lids 21 may be provided with handles 34 that define upwardly extending grippable regions 35 and hollow regions 36 located substantially below the grippable regions 35. Preferably the hollow regions  
30 36 of the handles 34 are complementary with the form of the main lid body when a handle is attached thereto. In this respect, the main lid body may have a convex portion centrally of a concave portion. The convex portion being suitable for accepting the hollow region 36 of a handle when such a handle is attached thereto.

When the lidded cookware vessels are sequentially nested, as shown in Figures 30 and 31, the grippable region 35 of an inner nested vessel may be at least partially received in the hollow region 36 of a more outwardly nested vessel. This may reduce interference between the lids and therefore allows for efficient nesting of a set of cookware vessels and their associated lids.

The handle 3 may fit within the most inwardly nested vessel as shown in Figure 31.

It is envisaged that sets of two or more cookware vessels may be provided with correspondingly sized lids and a handle. Such a set has the benefit whereby the handle can be used on any of the vessels of the set, and the lidded vessels may nest for efficient stowage as shown in Figures 30 and 31. Such a cookware set lends itself to situations where storage space is at a premium such as in apartments, boats, caravans etc.

Where in the foregoing description reference has been made to elements or integers having known equivalents, then such equivalents are included as if they were individually set forth.

Although the invention has been described by way of example and with reference to particular embodiments, it is to be understood that modifications and/or improvements may be made without departing from the scope or spirit of the invention.

**CLAIMS:**

1. **A cookware assembly or set** comprising or including:  
at least one cookware vessel of a substantially square peripheral exterior and interior  
5 form when viewed in plan, wherein the vessel has an attachment location on at least one of  
the four sides, the attachment location being a relief in the vessel's rim suitable for handle  
engagement, and  
a handle selectively engageable at the or any one of said attachment locations, the  
handle with both proximal and distal end regions having a pair of jaw elements at the  
10 proximal region for facilitating engagement to an attachment location such that a first jaw of  
the jaw pair locates substantially inside the vessel and a second jaw of the jaw pair locates  
substantially outside of the vessel, and  
a lid able to fit on the cookware vessel and to close, or at least substantially close,  
the cookware vessel.
- 15 2. A cookware assembly or set as claimed in claim 1 wherein the cookware vessel is of  
a form to enable nesting at least in part with a like vessel of a smaller or larger size, if not  
also partially nestable with one of the same size.
3. A cookware assembly or set as claimed in claim 1 or claim 2 wherein a plurality of  
like cookware vessels may sequentially nest, one within the other in order of their size, for  
20 efficient stowage.
4. A cookware assembly or set as claimed in claim 3 wherein each cookware vessel  
may sequentially nest, one within the other in order of their size, even with a corresponding  
lid located on each nested vessel.
5. A cookware assembly or set as claimed in claim 4 wherein each lid has a handle  
25 located substantially centrally of the lid body and has a grippable region extending upwardly  
substantially beyond the lid body, and a hollow region located below the grippable region,  
wherein the hollow region is dimensioned so that it can receive at least a portion of the  
grippable region of another like lid placed beneath so as to prevent interference between the  
lid handle and another lid when a plurality of cookware vessels are sequentially nested with  
30 their lids located thereon.
6. A cookware assembly or set as claimed in any of the previous claims wherein the  
position of one or both jaws of the jaw pair may be adjusted between a locked condition  
where the jaws are closer together than a further apart unlocked condition.

7. A cookware assembly or set as claimed in claim 6 wherein the handle has a lever to cause adjustment of the jaws between the locked and unlocked conditions.
8. A cookware assembly or set as claimed in claim 7 wherein the lever can articulate between at least two stable conditions, one of which positions corresponds to the locked condition of the jaw pair, the other corresponding to the unlocked condition of the jaw pair.
9. A cookware assembly or set as claimed in claim 8 wherein the articulation of the lever causes a sliding and/or otherwise guided member as a second jaw element to move relative to a more proximal fixed jaw element.
10. A cookware assembly or set as claimed in any of the previous claims wherein the jaw pair are shaped such that they are complementary with the attachment location to lock the handle to the vessel in a rigid, weight bearing manner.
11. A cookware assembly or set as claimed in any of the previous claims wherein the second jaw of the jaw pair engages under the relief feature of the rim.
12. A cookware assembly or set as claimed in any of the previous claims wherein the relief in the rim restricts movement of an attached handle along the rim of the vessel.
13. A cookware assembly or set as claimed in any of the preceding claims wherein the lid includes a relief substantially on its periphery to accommodate the handle when such is engaged at an attachment location.
14. A cookware assembly or set as claimed in claim 13 wherein the lid includes a slideable member able to encroach over the relief to reduce venting during cooking.
15. A cookware assembly or set as claimed in claim 14 wherein the slideable member can encroach over the relief to such an extent that the lid can substantially seal the vessel to which the lid is associated.
16. **A handle** suitable for attachment to a cookware vessel, the handle comprising or including:  
a pair of jaw elements at a proximal region of the handle,  
an actuator to adjust the relative position of the pair of jaw elements,  
wherein the relative position of the jaw elements facilitates attachment of the handle to an attachment location provided as a relief in the rim of a cookware vessel such that a first jaw of the jaw pair locates substantially inside the vessel and a second jaw of the jaw pair locates substantially outside of the vessel .
17. A handle as claimed in claim 16 wherein the position of one or both jaws of the jaw pair may be adjusted between a locked condition where the jaws are closer together than a further apart, unlocked condition.

18. A handle as claimed in claim 17 wherein the actuator is a lever to cause adjustment of the jaws between the locked and unlocked conditions.
19. A handle as claimed in claim 18 wherein the lever can articulate between at least two stable conditions, one of which positions corresponds to the locked condition of the jaw pair, the other corresponding to the unlocked condition of the jaw pair.
20. A handle as claimed in claim 19 wherein the articulation of the lever causes a sliding and/or otherwise guided member as a second jaw element to move relative to a more proximal fixed jaw element.
21. A handle as claimed in claim 20 wherein the lever has a cam profile that engages the sliding member, the arrangement being such that, via articulation of the lever, the cam profile can be pivoted outwardly from a condition that stably holds the sliding member in a locked condition closer to the first mentioned jaw yet allows the retreat of the sliding member to an unlocked condition under the action of a bias when the cam is moved or urged away from that condition.
22. A handle as claimed in claim 21 wherein the sliding member is biased towards the cam profile of the lever.
23. A handle as claimed in any of claims 16 to 22 wherein the jaw pair are shaped such that they are complementary with the attachment location of the cookware vessel to lock the handle to the vessel in a rigid, weight bearing manner.
24. A **lid** for, or suitable for, a cookware vessel of a substantially square or rectangular peripheral exterior and interior form when viewed in plan, save optionally for rounded transitions between the adjacent sides, said lid being an assembly defining  
a lid body having a relief on its periphery that accords to a centre of a side of such a cookware vessel,  
a slide or other moveable member carried by the lid body able to close the relief,  
and  
a handle feature of the lid carried by the lid body.
25. A lid as claimed in claim 24 wherein the handle is located substantially centrally of the lid body and has a grippable region extending upwardly substantially beyond the lid body, and a hollow region located below the grippable region, wherein the hollow region is dimensioned so that it can receive at least a portion of the grippable region of another like lid placed beneath so as to prevent interference between the lid handle and another lid when a plurality of cookware vessels are sequentially nested with their lids located thereon.

26. A lid as claimed in claims 24 or 25 wherein the slideable member can encroach over the relief to such an extent that the lid can substantially seal a vessel to which the lid is associated.
27. A **cookware vessel** that includes at least one handle attachment location defined on the rim of the vessel, the handle attachment location being suitable for selective attachment of a handle, **wherein** the handle attachment location is recessed from the surrounding rim to restrict movement of an attached handle along the rim of the vessel.
28. A cookware vessel as claimed in claim 27 wherein the cookware vessel is of a form to enable nesting at least in part with a like vessel of a smaller or larger size, if not also partially nestable with one of the same size.
29. A cookware vessel as claimed in claim 27 or 28 wherein a plurality of like cookware vessels may sequentially nest, one within the other in order of their size, even with a corresponding lid located on each vessel.
30. **A cookware assembly or set** comprising two or more cookware vessels and lids corresponding to each cookware vessel,  
**wherein** each lidded cookware vessel is sequentially nested, or may sequentially nest, one within the other, or another, in order of their size in an efficient manner.
31. A cookware assembly or set as claimed in claim 30 wherein a handle engageable to either, or any, of the vessels is located in the smaller or smallest vessel.
32. In another aspect the present invention consists in **a cookware vessel** substantially as herein described with reference to any one or more of the accompanying drawings.
33. In another aspect the present invention consists in **a handle** suitable for a cookware vessel substantially as herein described with reference to any one or more of the accompanying drawings.
34. In another aspect the present invention consists in **a lid** for a cookware vessel substantially as herein described with reference to any one or more of the accompanying drawings.
35. In another aspect the present invention consists in **a cookware assembly or set** for a substantially as herein described with reference to any one or more of the accompanying drawings.

FIGURE 2

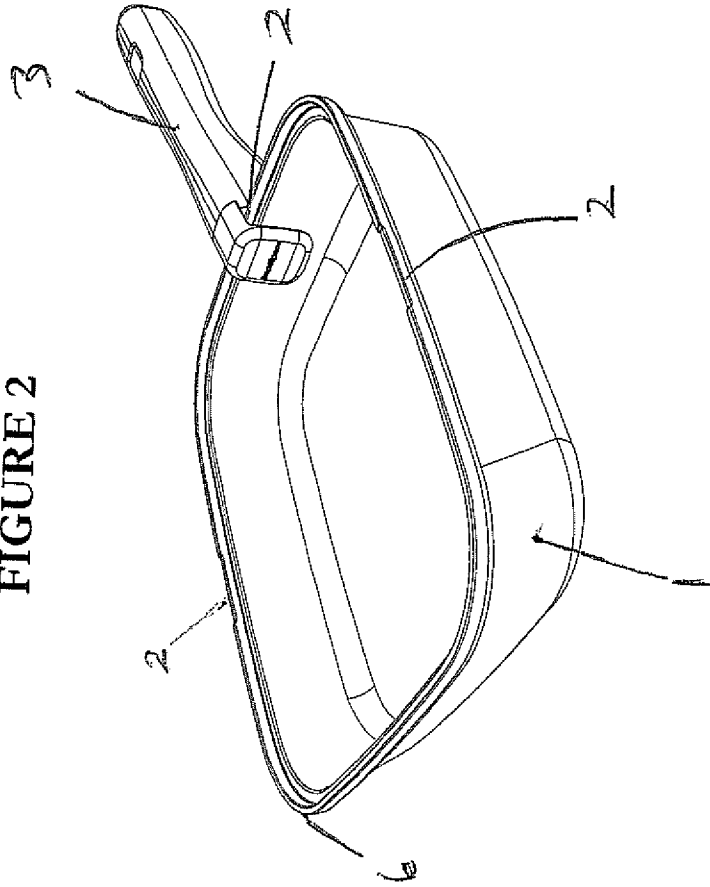
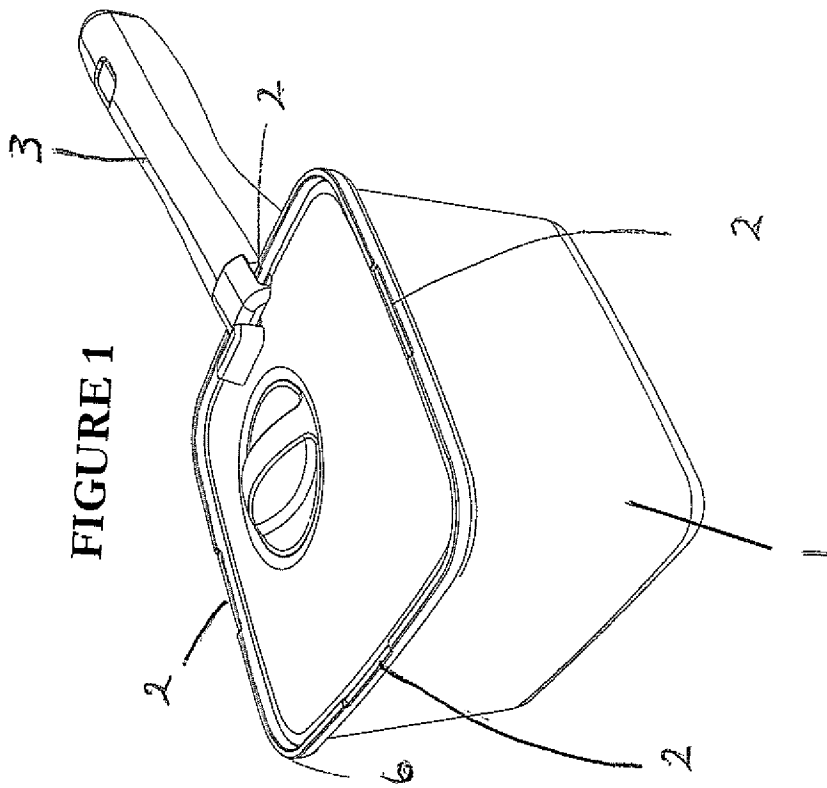

FIGURE 1



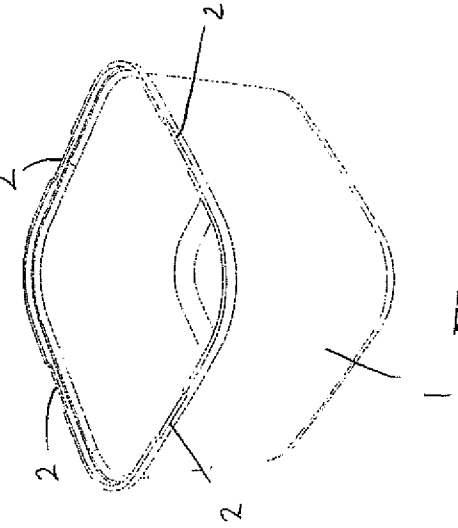
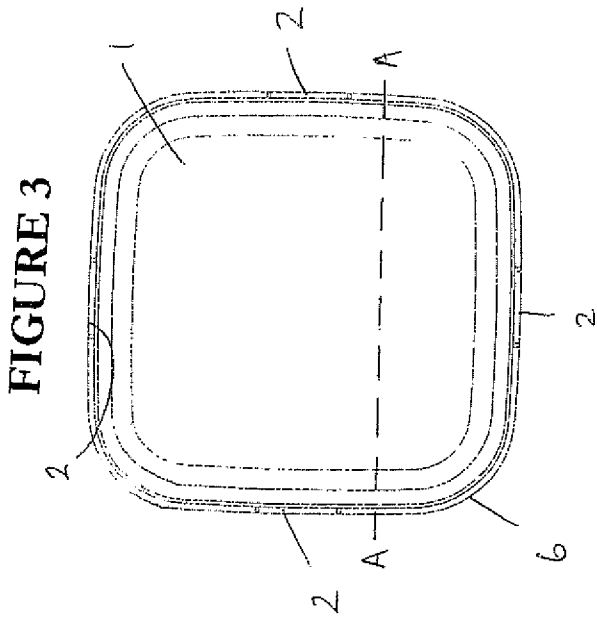

FIGURE 6

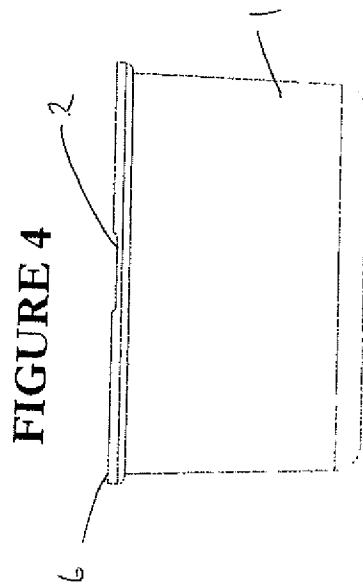

FIGURE 4

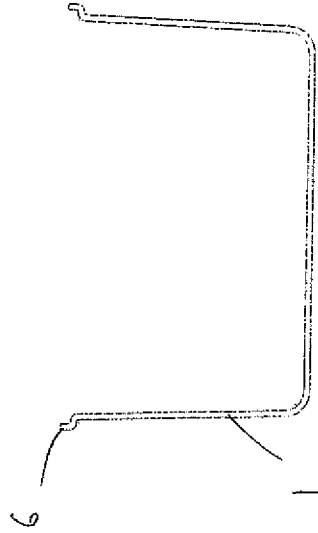

FIGURE 5

FIGURE 11

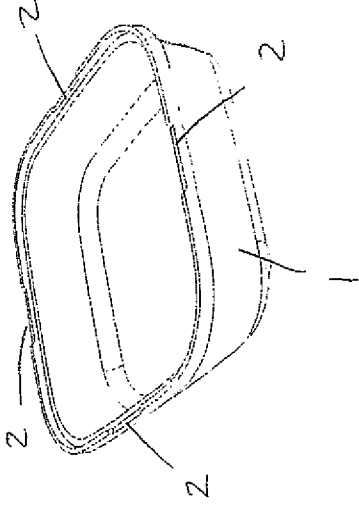

FIGURE 10

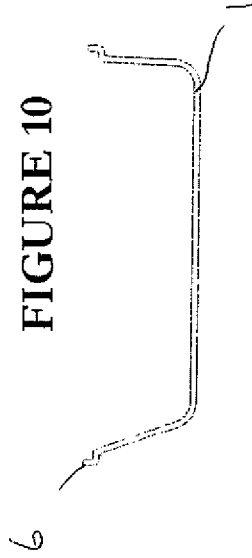

FIGURE 9

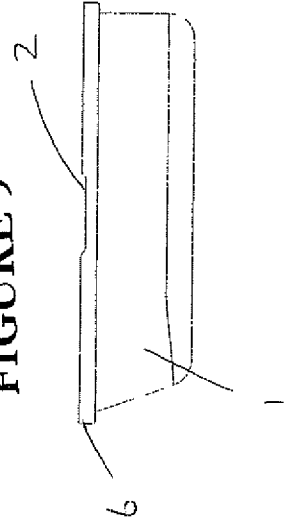

FIGURE 7

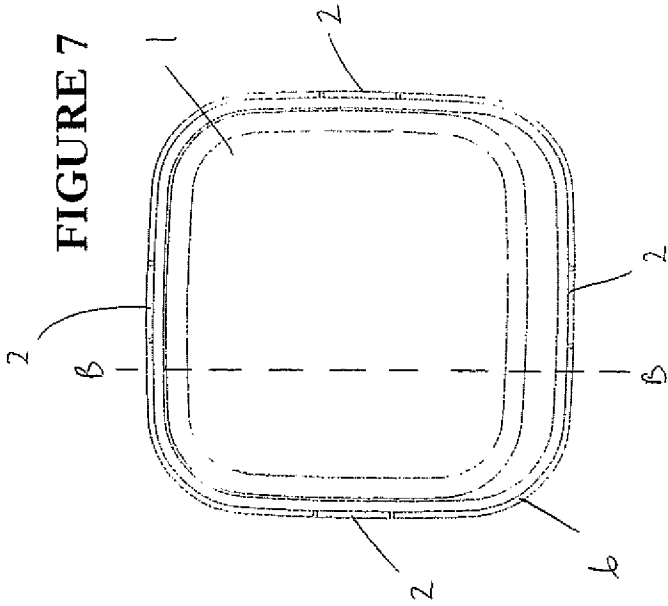

FIGURE 8

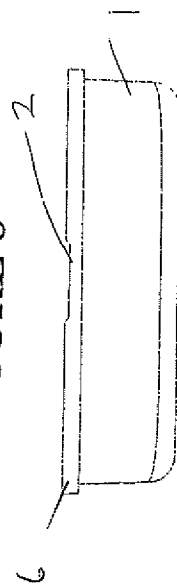

FIGURE 15

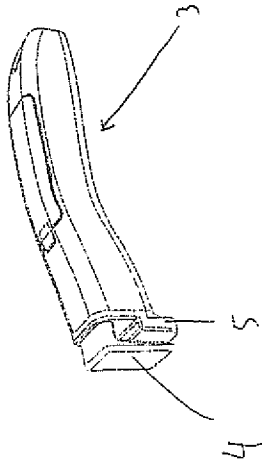

FIGURE 14

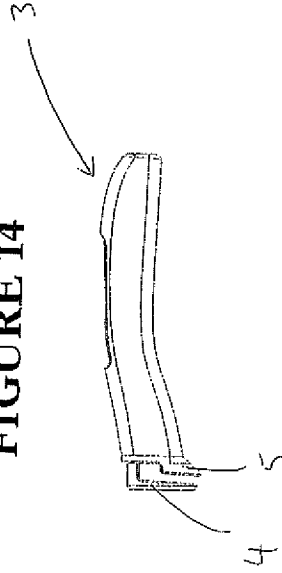

FIGURE 12

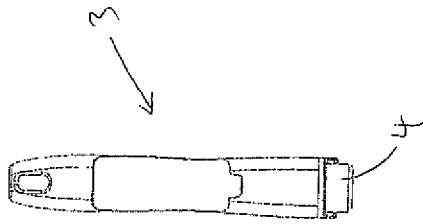

FIGURE 13

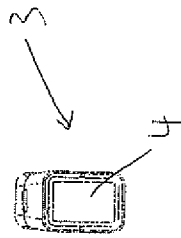

FIGURE 16

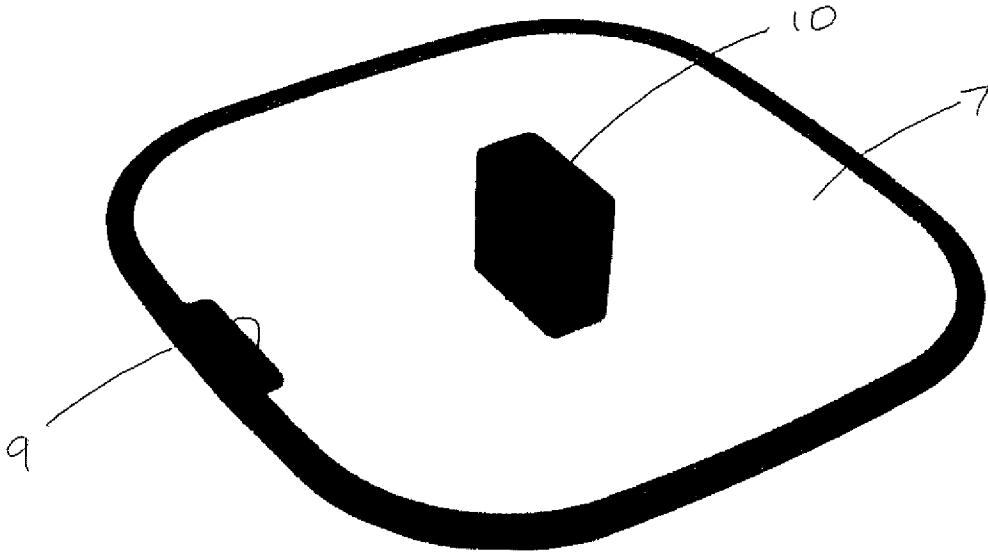
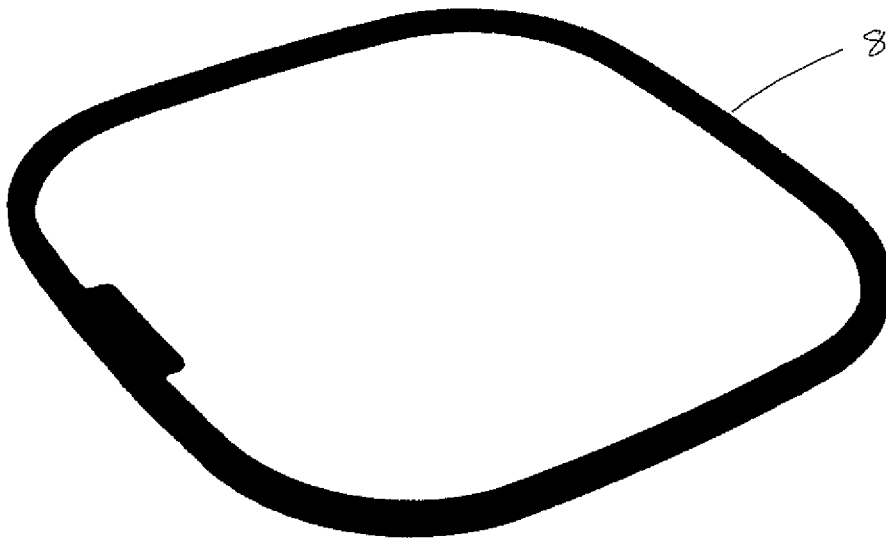

FIGURE 17



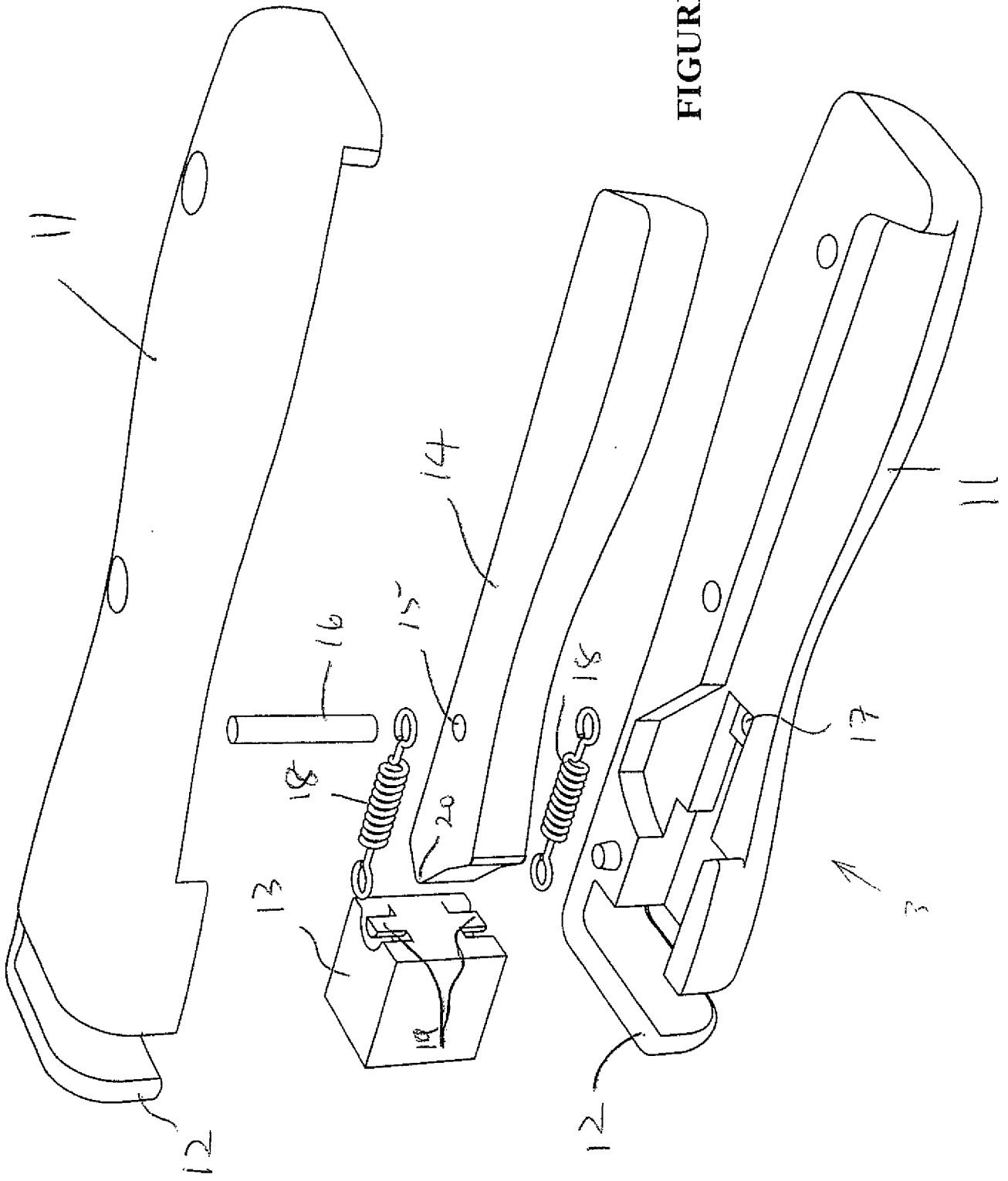

FIGURE 18

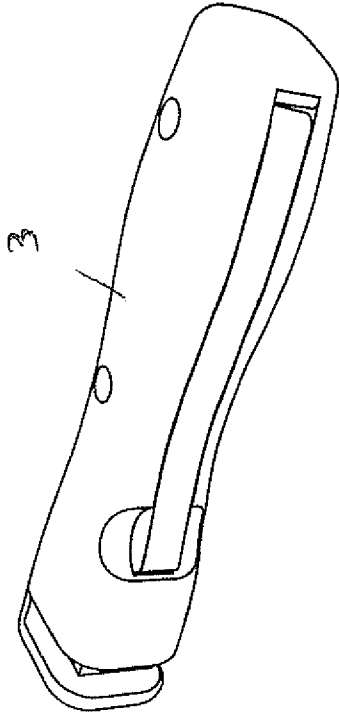

FIGURE 20

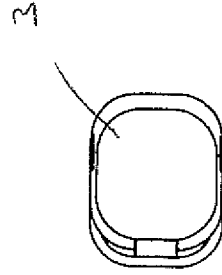

FIG 22

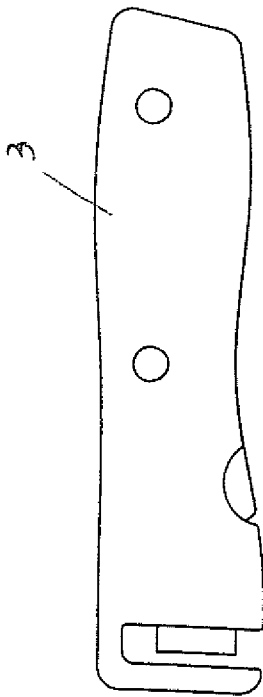

FIGURE 19

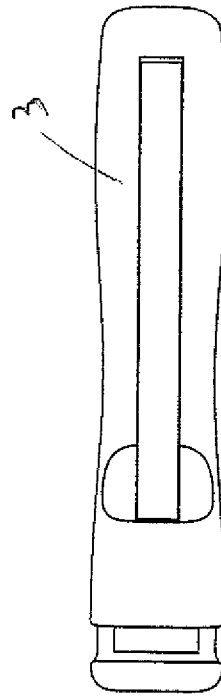

FIGURE 21

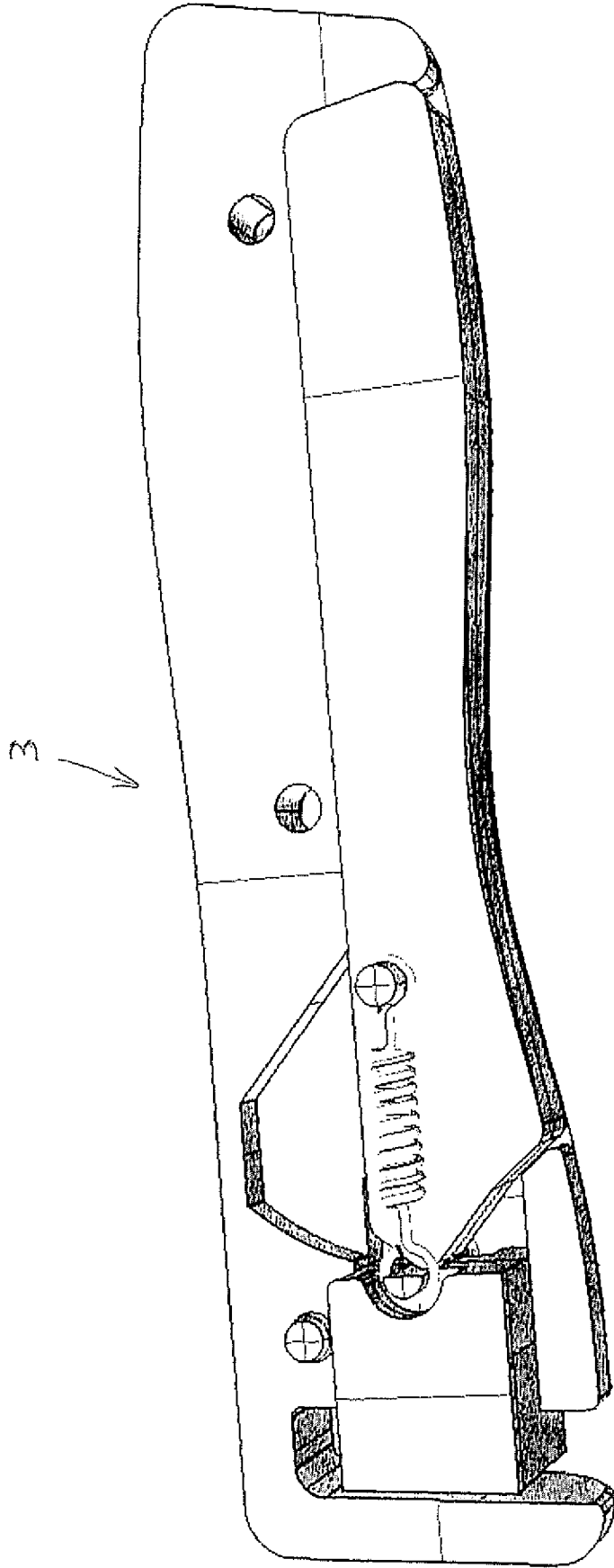

FIGURE 22A

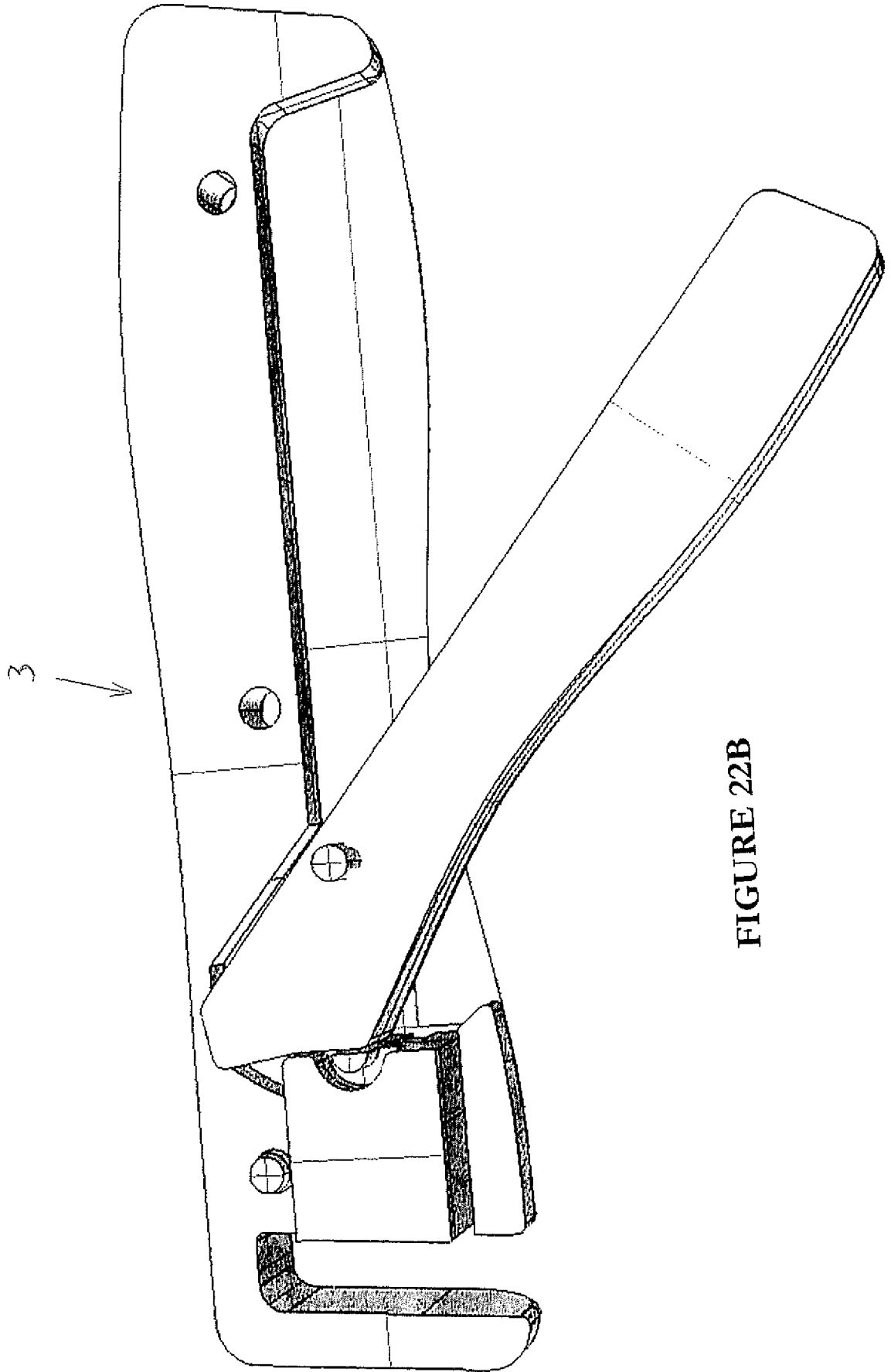

FIGURE 22B

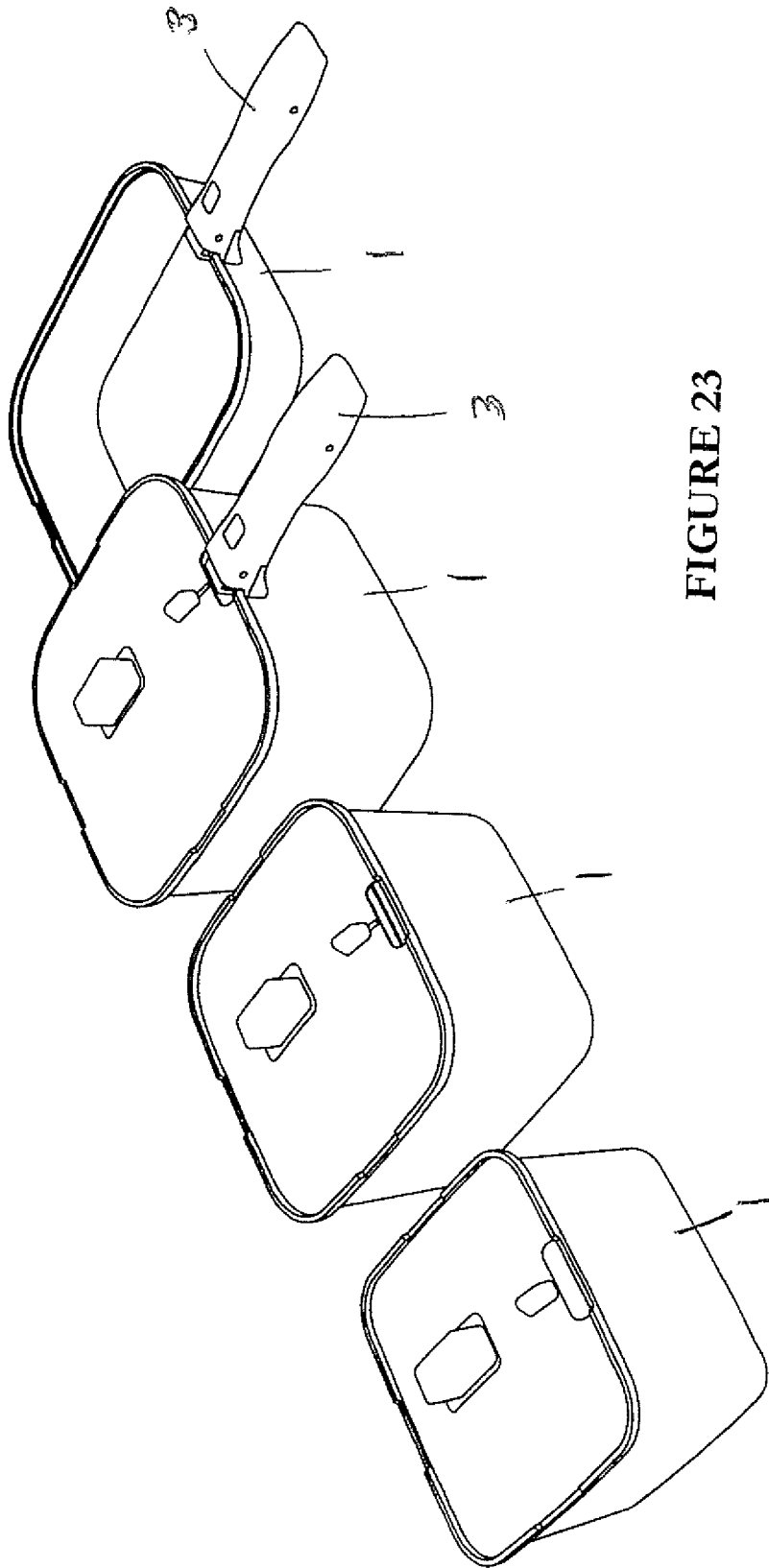

FIGURE 23

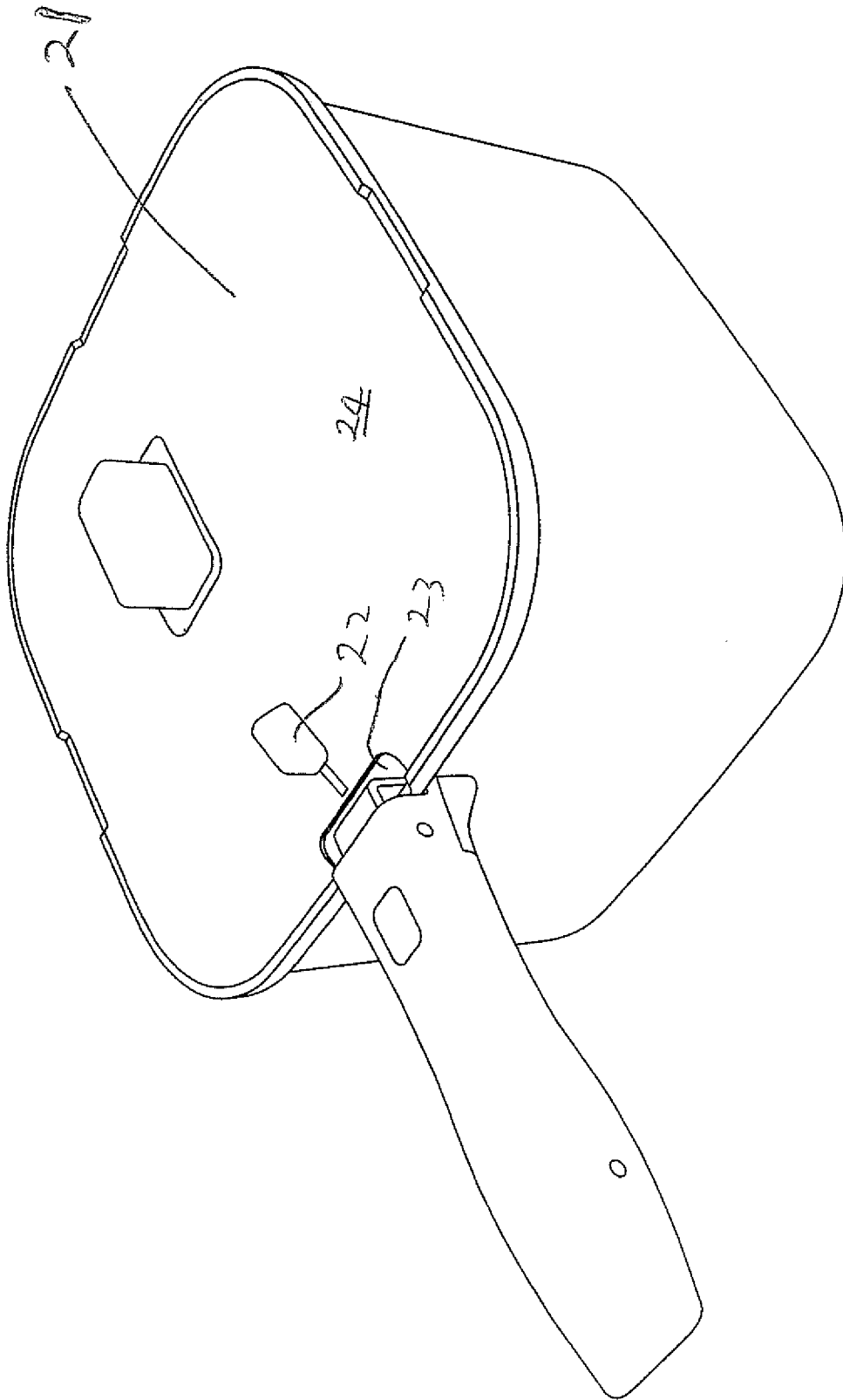

FIGURE 24

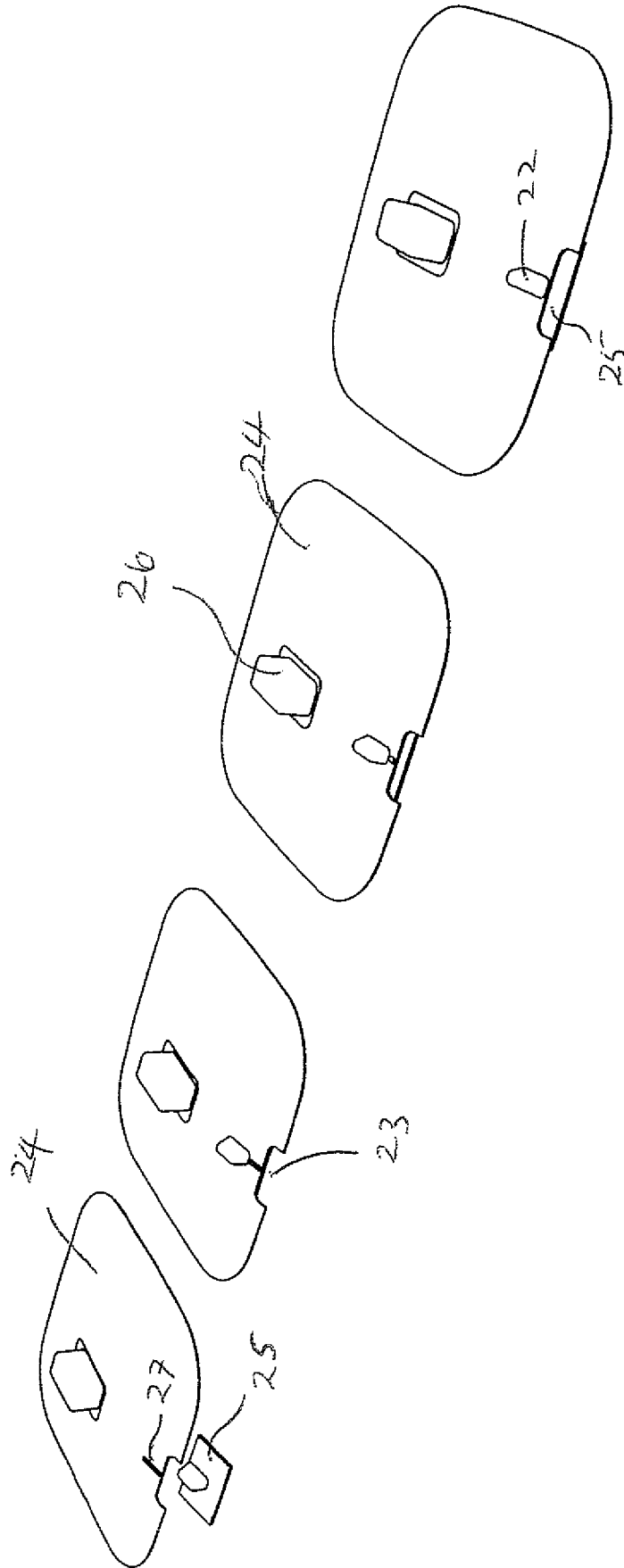

FIGURE 25

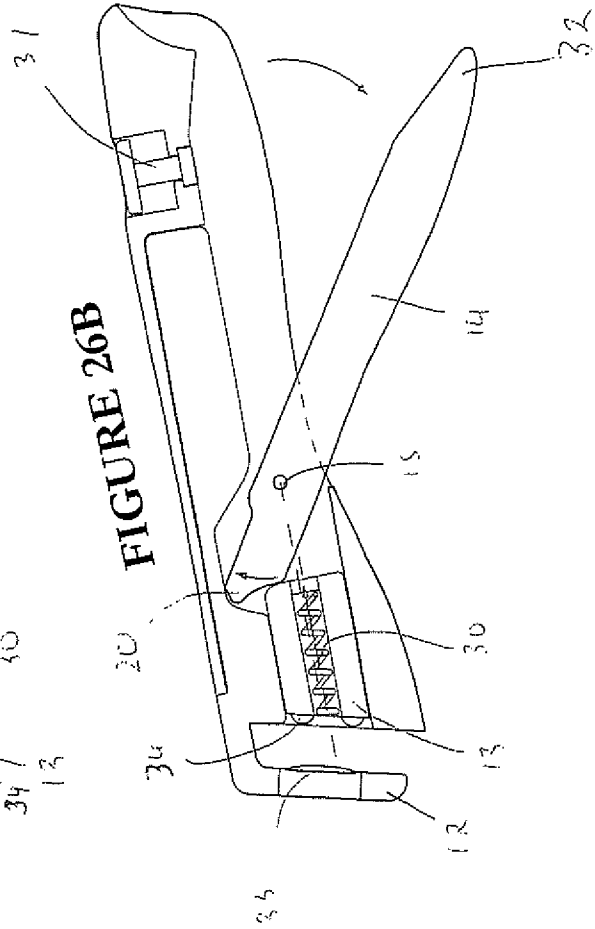
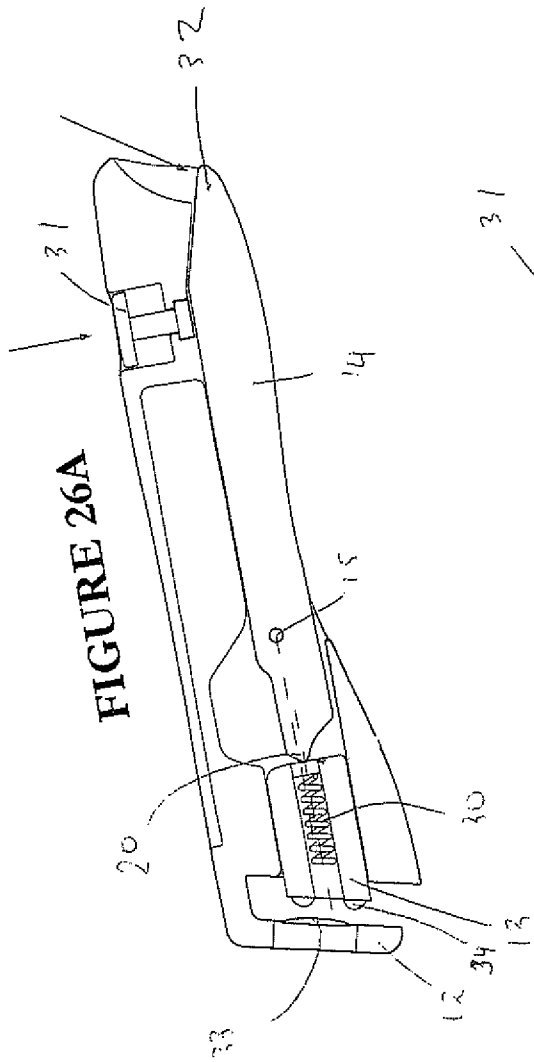

FIGURE 27

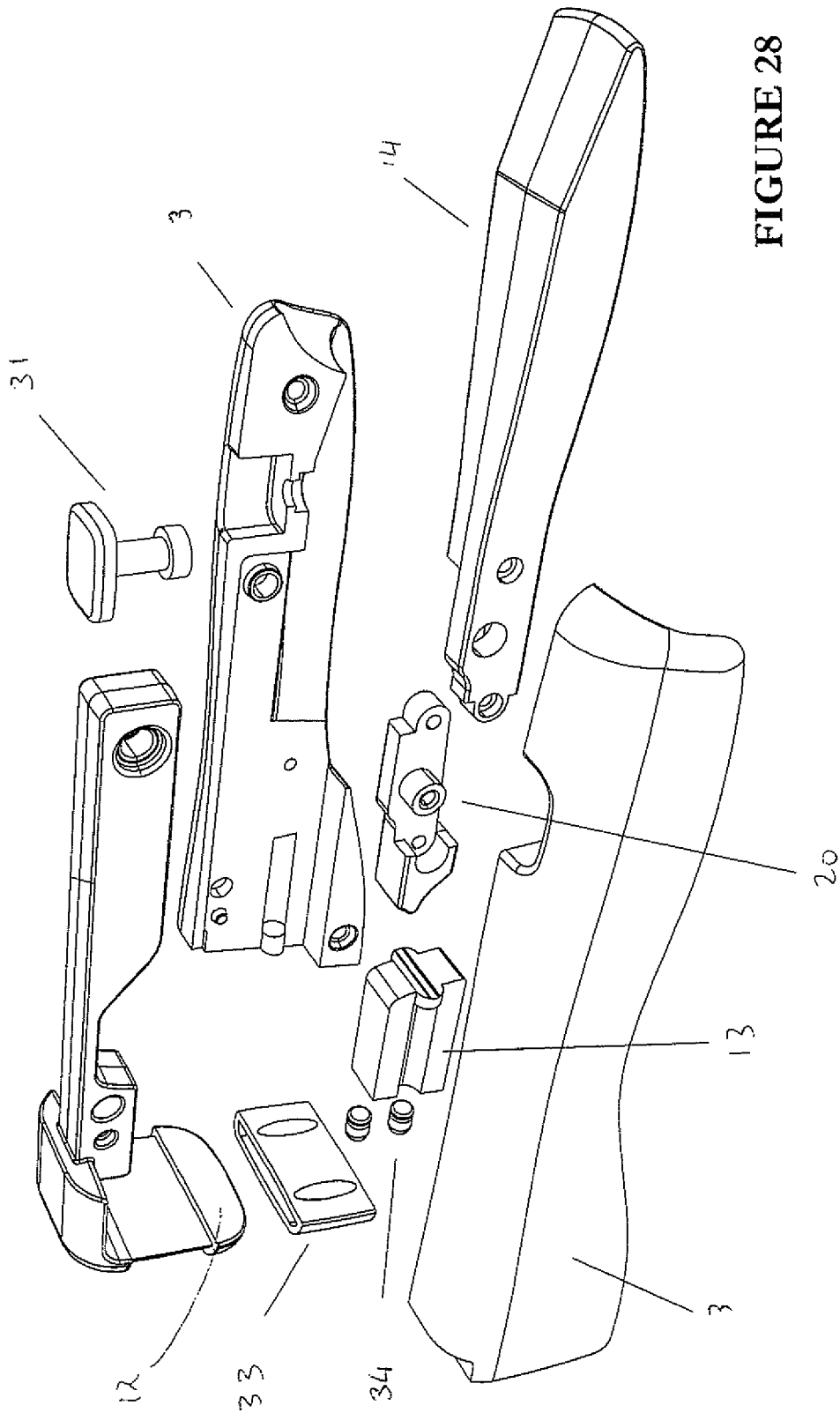

FIGURE 28

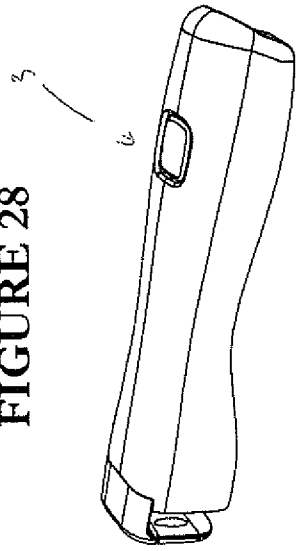
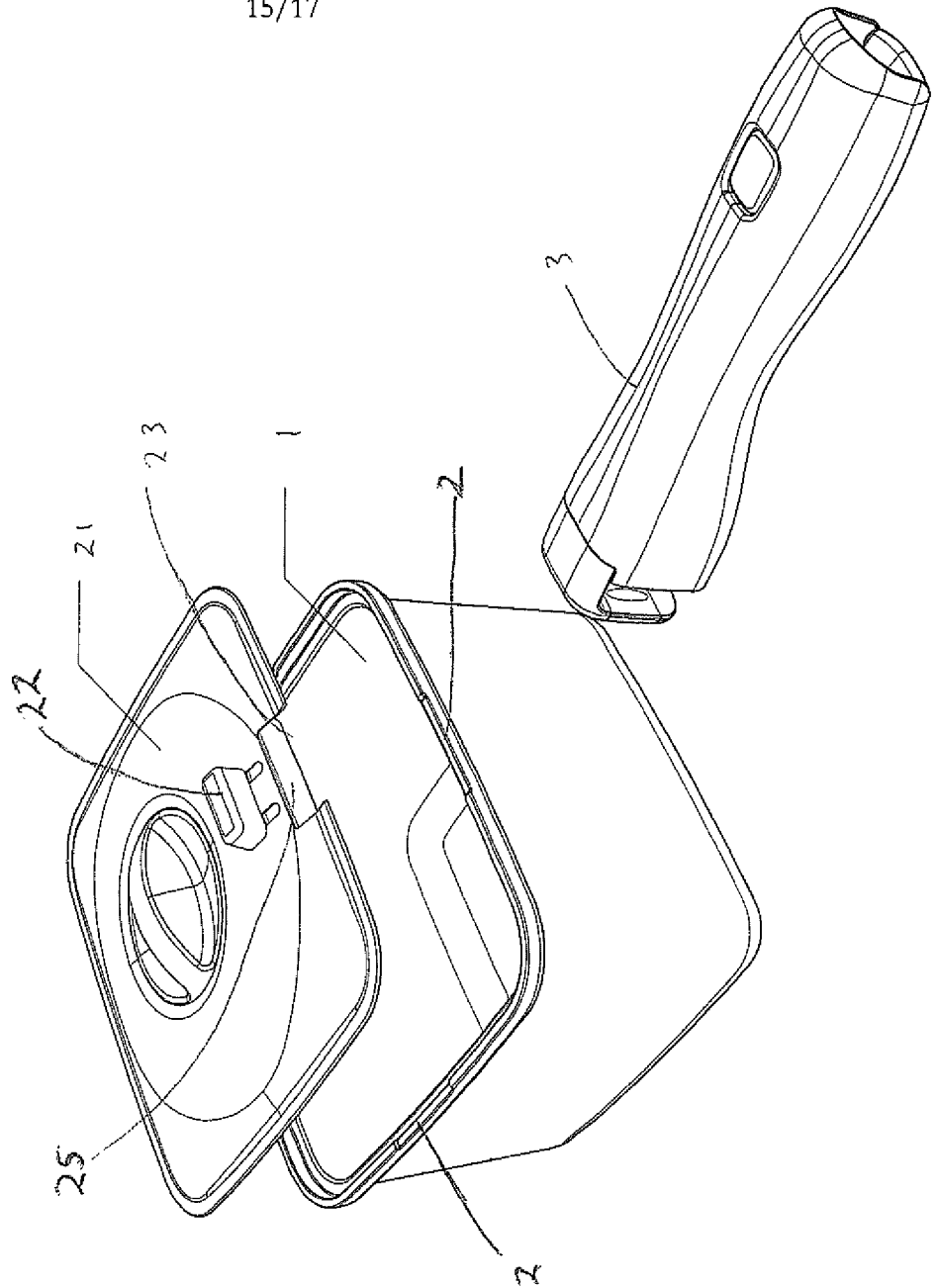

FIGURE 29



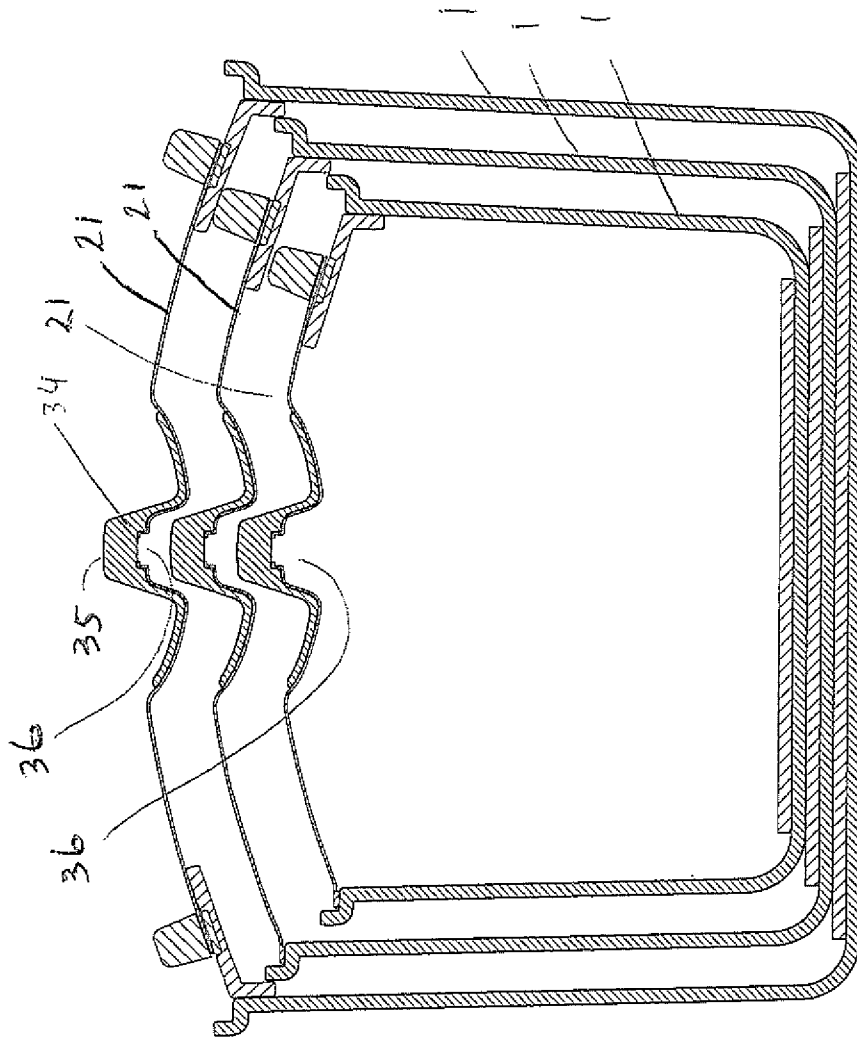

FIGURE 30

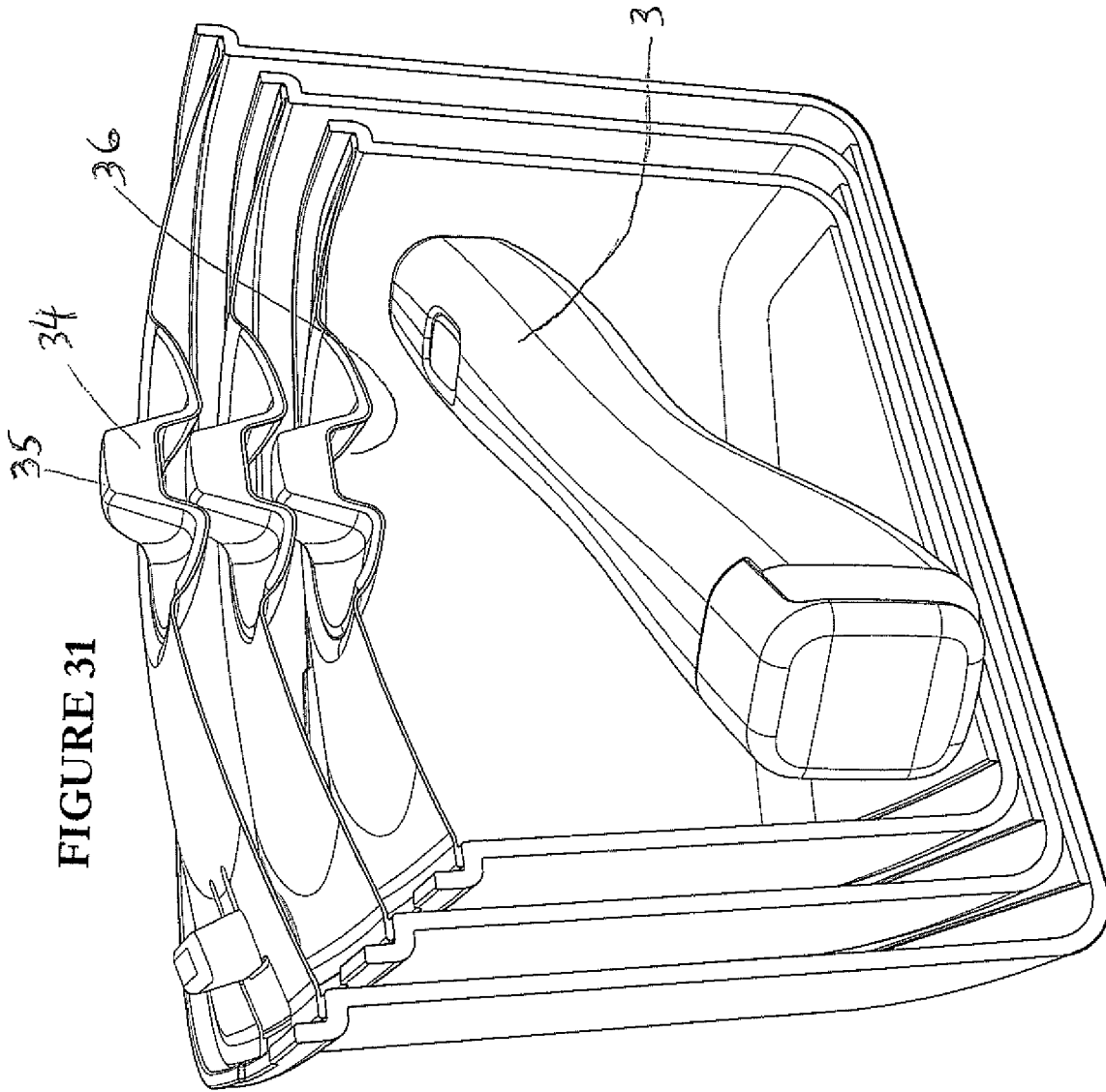

FIGURE 31

## INTERNATIONAL SEARCH REPORT

International application No.

PCT/IB2011/052768

## A. CLASSIFICATION OF SUBJECT MATTER

Int. Cl.

A47J 27/00 (2006.01)

A47J 36/00 (2006.01)

According to International Patent Classification (IPC) or to both national classification and IPC

## B. FIELDS SEARCHED

Minimum documentation searched (classification system followed by classification symbols)

Documentation searched other than minimum documentation to the extent that such documents are included in the fields searched

Electronic data base consulted during the international search (name of data base and, where practicable, search terms used)

WPI, EPODOC : IPC, ECLA A47J &amp; Key words (handle, remov+, +attach+, jaw+, grip+, clamp+, inside, interior, inner, outside, exterior, outer, cookware, saucepan, rim, edge, +pan, depression, slot+, groove, mate, rebate,

## C. DOCUMENTS CONSIDERED TO BE RELEVANT

Category*	Citation of document, with indication, where appropriate, of the relevant passages	Relevant to claim No.
X	JP 2001157634 A (KANSAI KEIKINZOKU KOGYO KK) 12 June 2001 Figs 1-7 & English abstract retrieved from EPODOC database	1-23
A	FR 2244435 A1 (DURAND CIE VERRERIE CRISTALLER) 18 April 1975 Figs 1, 2 & English abstract retrieved from EPODOC database	
A	FR 2287884 A2 (DURAND CIE VERRERIE CRISTALLER) 14 May 1976 Figs 3, 4 & English abstract retrieved from EPODOC database	
A	US 5704092 A (NICOLLET et al.) 6 January 1998 Abstract & figs 1-3	



Further documents are listed in the continuation of Box C



See patent family annex

* Special categories of cited documents:		
"A" document defining the general state of the art which is not considered to be of particular relevance	"T" later document published after the international filing date or priority date and not in conflict with the application but cited to understand the principle or theory underlying the invention	
"E" earlier application or patent but published on or after the international filing date	"X" document of particular relevance; the claimed invention cannot be considered novel or cannot be considered to involve an inventive step when the document is taken alone	
"L" document which may throw doubts on priority claim(s) or which is cited to establish the publication date of another citation or other special reason (as specified)	"Y" document of particular relevance; the claimed invention cannot be considered to involve an inventive step when the document is combined with one or more other such documents, such combination being obvious to a person skilled in the art	
"O" document referring to an oral disclosure, use, exhibition or other means	"&" document member of the same patent family	
"P" document published prior to the international filing date but later than the priority date claimed		

Date of the actual completion of the international search

22 September 2011

Date of mailing of the international search report

28/09/2011

Name and mailing address of the ISA/AU

AUSTRALIAN PATENT OFFICE  
PO BOX 200, WODEN ACT 2606, AUSTRALIA  
E-mail address: pct@ipaaustralia.gov.au  
Facsimile No. +61 2 6283 7999

Authorized officer

**SARAVANAMUTHU PONNAMPALAM**  
AUSTRALIAN PATENT OFFICE  
(ISO 9001 Quality Certified Service)  
Telephone No : (02) 6283 2070

**Box No. II Observations where certain claims were found unsearchable (Continuation of item 2 of first sheet)**

This international search report has not been established in respect of certain claims under Article 17(2)(a) for the following reasons:

1.  Claims Nos.:  
because they relate to subject matter not required to be searched by this Authority, namely:
  
2.  Claims Nos.: **32 - 35**  
because they relate to parts of the international application that do not comply with the prescribed requirements to such an extent that no meaningful international search can be carried out, specifically:  
  
The claims 32-35 do not comply with Rule 6.2(a) because they rely on references to the description and/or drawings.
  
3.  Claims Nos.:  
because they are dependent claims and are not drafted in accordance with the second and third sentences of Rule 6.4(a)

**Box No. III Observations where unity of invention is lacking (Continuation of item 3 of first sheet)**

This International Searching Authority found multiple inventions in this international application, as follows:

- (a) claims 1-23
- (b) claims 24-26
- (c) claims 27-29
- (d) claims 30-31

(Continued in Supplemental Box I)

1.  As all required additional search fees were timely paid by the applicant, this international search report covers all searchable claims.
2.  As all searchable claims could be searched without effort justifying additional fees, this Authority did not invite payment of additional fees.
3.  As only some of the required additional search fees were timely paid by the applicant, this international search report covers only those claims for which fees were paid, specifically claims Nos.:
  
4.  No required additional search fees were timely paid by the applicant. Consequently, this international search report is restricted to the invention first mentioned in the claims; it is covered by claims Nos.: **1-23**

**Remark on Protest**

- The additional search fees were accompanied by the applicant's protest and, where applicable, the payment of a protest fee.
- The additional search fees were accompanied by the applicant's protest but the applicable protest fee was not paid within the time limit specified in the invitation.
- No protest accompanied the payment of additional search fees.

**Supplemental Box I**

(To be used when the space in any of Boxes I to IV is not sufficient)

**Continuation of Box No: III**

This International Application does not comply with the requirements of unity of invention because it does not relate to one invention or to a group of inventions so linked as to form a single general inventive concept.

This Authority has found that there are different inventions based on the following features that separate the claims into distinct groups:

- Claims 1-23. The feature of a first jaw of the jaw pair locates substantially inside the vessel and a second jaw of the jaw pair locates substantially outside of the vessel is specific to this group of claims.
- Claims 24-26. The feature of a slide or other moveable member carried by the lid body able to close the relief is specific to this group of claims.
- Claims 27-29. The feature of the handle attachment location is recessed from the surrounding rim to restrict movement of an attached handle along the rim of the vessel is specific to this group of claims.
- Claims 30-31. The feature of each lidded cookware vessel is sequentially nested, or may sequentially nest, one within the other, or another, in order of their size in an efficient manner is specific to this group of claims.

PCT Rule 13.2, first sentence, states that unity of invention is only fulfilled when there is a technical relationship among the claimed inventions involving one or more of the same or corresponding special technical features. PCT Rule 13.2, second sentence, defines a special technical feature as a feature which makes a contribution over the prior art.

When there is no special technical feature there is no unity of invention.

In the above groups of claims, the identified features may have the potential to make a contribution over the prior art but are not common to all the claims and therefore cannot provide the required technical relationship. Therefore there is no special technical feature present in the claims and the requirements for unity of invention are consequently not satisfied *a priori*.

**INTERNATIONAL SEARCH REPORT**

Information on patent family members

International application No.

**PCT/IB2011/052768**

This Annex lists the known "A" publication level patent family members relating to the patent documents cited in the above-mentioned international search report. The Australian Patent Office is in no way liable for these particulars which are merely given for the purpose of information.

Patent Document Cited in Search Report		Patent Family Member					
JP	2001157634	NONE					
FR	2244435	NONE					
FR	2287884	NONE					
US	5704092	CA	2187721	CN	1151855	EP	0769263
		FR	2739771	FR	2739772	IN	188527
		JP	9164085	TR	970392		
Due to data integration issues this family listing may not include 10 digit Australian applications filed since May 2001.							
END OF ANNEX							