



(43) International Publication Date
13 September 2012 (13.09.2012)

(51) International Patent Classification:

B26B 27/00 (2006.01) *B60J 10/02* (2006.01)
B26D 1/547 (2006.01) *B60S 5/00* (2006.01)
B60J 1/00 (2006.01)

(21) International Application Number:

PCT/SE2011/050249

(22) International Filing Date:

4 March 2011 (04.03.2011)

(25) Filing Language:

English

(26) Publication Language:

English

(71) Applicant (for all designated States except US): **RAMHUSSET PATENT AB** [SE/SE]; Sturegatan 67, S-791 62 Falun (SE).

(72) Inventor; and

(75) Inventor/Applicant (for US only): **ERICSON, Rolf** [SE/SE]; Torkelsväg 40 D, S-791 52 Falun (SE).

(74) Agent: **AROS PATENT AB**; P.O.Box 1544, S-751 45 Uppsala (SE).

(81) Designated States (unless otherwise indicated, for every kind of national protection available): AE, AG, AL, AM, AO, AT, AU, AZ, BA, BB, BG, BH, BR, BW, BY, BZ, CA, CH, CL, CN, CO, CR, CU, CZ, DE, DK, DM, DO,

DZ, EC, EE, EG, ES, FI, GB, GD, GE, GH, GM, GT, HN, HR, HU, ID, IL, IN, IS, JP, KE, KG, KM, KN, KP, KR, KZ, LA, LC, LK, LR, LS, LT, LU, LY, MA, MD, ME, MG, MK, MN, MW, MX, MY, MZ, NA, NG, NI, NO, NZ, OM, PE, PG, PH, PL, PT, RO, RS, RU, SC, SD, SE, SG, SK, SL, SM, ST, SV, SY, TH, TJ, TM, TN, TR, TT, TZ, UA, UG, US, UZ, VC, VN, ZA, ZM, ZW.

(84) Designated States (unless otherwise indicated, for every kind of regional protection available): ARIPO (BW, GH, GM, KE, LR, LS, MW, MZ, NA, SD, SL, SZ, TZ, UG, ZM, ZW), Eurasian (AM, AZ, BY, KG, KZ, MD, RU, TJ, TM), European (AL, AT, BE, BG, CH, CY, CZ, DE, DK, EE, ES, FI, FR, GB, GR, HR, HU, IE, IS, IT, LT, LU, LV, MC, MK, MT, NL, NO, PL, PT, RO, RS, SE, SI, SK, SM, TR), OAPI (BF, BJ, CF, CG, CI, CM, GA, GN, GQ, GW, ML, MR, NE, SN, TD, TG).

Declarations under Rule 4.17:

- as to applicant's entitlement to apply for and be granted a patent (Rule 4.17(ii))
- of inventorship (Rule 4.17(iv))

Published:

- with international search report (Art. 21(3))

(54) Title: WINCH FRICTION BRAKE, METHOD AND WINCH TOOL

FIG. 2

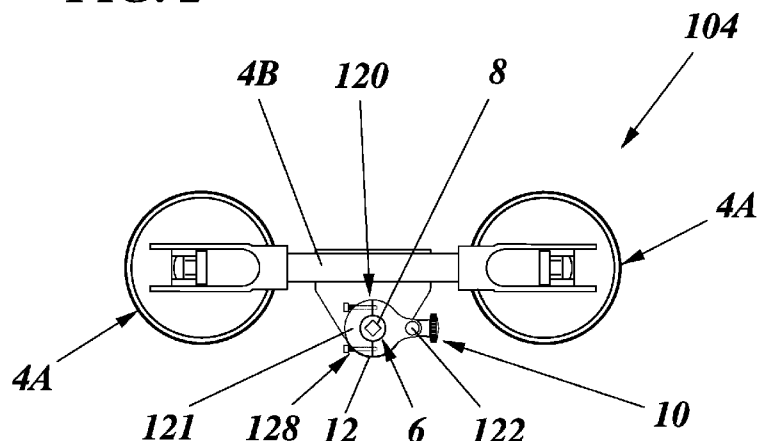

(57) Abstract: In a method for removing a window element from a vehicle by cutting through an adhesive bonding the window element to the vehicle, winches (6) of at least one winch tool (104) are alternately operated for tensioning and winding a cutting wire to cut through the adhesive around the window element, said winches having a ratchet mechanism (10) for blocking winch rotation in a winch unwinding direction opposite a winch winding direction, whereby the tensioning of the cutting wire that is caused by the operation of one winch is adjusted by temporarily deactivating a ratchet mechanism of an associated non-operated winch and by functionally replacing said ratchet mechanism by a friction brake assembly (120) resisting rotation in said unwinding direction of said non-operated winch. A winch tool with at least one winch for tensioning and winding a cutting wire as well as a friction brake for such a winch or winches are also provided.

WO 2012/121631 A1

TITLE: WINCH FRICTION BRAKE, METHOD AND WINCH TOOL**TECHNICAL FIELD**

The present invention generally concerns winches and more specifically relates to the type of
5 wire winding winch tools that are frequently used for cutting out adhesively bonded window
elements from vehicles.

BACKGROUND

Nowadays fixed window elements in vehicles are typically adhesively bonded to the vehicle
10 body, in automobiles commonly also contributing to the structural strength of the body. This
has in turn resulted in the development of window removal methods and techniques for
effectively loosening or removing the adhesive bond. Basically, one such technique involves
the use of a cutting wire that is introduced through the window bonding adhesive, from one
side of the window element to the opposite side thereof. In the earliest cutting wire
15 techniques such an introduced cutting wire was basically pulled back and forth to produce a
kind of sawing action to cut through the bond. In an alternative early solution a hand
manipulated heated knife-like tool was used to successively penetrate and loosen the ad-
hesive bond between the window element and the body. All of such early techniques were
quite laboursome, difficult and time consuming to carry out since they were basically per-
20 formed quite manually without any devices for assisting the movement of the cutting wire or
of the heated knife. They did also frequently cause damage to the vehicle, such as to the
paint, to the dashboard and/or to the upholstery.

Today, the cutting wire technique has been further developed to provide more effective, safe
25 and less laboursome cutting. An important development was the quite recent introduction of
wire winch tools for pulling a cutting wire successively through the adhesive bond around an
entire window element. The tool/tools are secured by suction cups to one side of a vehicle
windshield. Separate winches are provided for pulling a respective end of a cutting wire that
is positioned in a loop around the entire periphery of the opposite side of the window. The
30 wire ends are threaded through the adhesive bond and are attached to the respective winch to
be wound up on an associated wire spool. This winch tool technique has generally been very
successful and is commonly used in numerous countries. In some instances and especially
with some types of tools it is difficult though to continuously optimize the cutting properties,
such as cutting angles and cutting force, during operation. This is mainly due to the fact that

repositioning of the winch tools is quite difficult and/or may result in uncontrolled unwinding of wire wound onto a wire spool. As a result thereof cutting wire failure does occur due to excessive cutting forces being applied thereto by winch tools that are not properly positioned.

5 SUMMARY

A general object of the present invention is to provide a solution to the described problems.

In particular it is an object of the invention to suggest an improved method of removing vehicle window elements.

10

In particular it is another object of the invention to suggest an improved winch tool for use in removing vehicle window elements.

In particular it is yet another object of the invention to suggest an improved friction brake
15 assembly for a winch used in removing vehicle window elements.

These and other objects are met by the invention as defined by the accompanying claims.

The invention generally relates to the removal of window elements from vehicles by cutting
20 through adhesive bonding the window element to the vehicle by means of a cutting wire. Separate winches of one or several winch tools are alternately operated for tensioning and winding the cutting wire to cut through the adhesive around the window element. Winch rotation in a winch unwinding direction opposite a winch winding direction is blocked by a ratchet mechanism of the winches. In a basic configuration the tensioning of the cutting wire
25 that is caused by the operation of one winch is adjusted. This adjustment is provided by temporarily deactivating a ratchet mechanism of an associated non-operated winch and by functionally replacing this ratchet mechanism by a friction brake assembly resisting rotation of the non-operated winch in the unwinding direction.

30 In another aspect the invention generally relates to a winch tool having at least one winch for tensioning and winding a cutting wire when operated, whereby the cutting wire is tensioned and wound to cut through adhesive bonding a window element to a vehicle. The winch or each winch has a ratchet mechanism for blocking rotation thereof in a winch unwinding

direction opposite a winch winding direction and has a cutting wire spool fixed to a winch operating means. In a basic configuration the or each winch of the winch tool has a friction brake assembly that fits onto the winch operating means. In the fitted condition the friction brake assembly deactivates the winch ratchet mechanism and it includes a brake pad that in
5 the fitted condition frictionally engages the winch operating means resisting rotation thereof and thereby resisting unwinding of cutting wire from the associated wire spool.

In yet another aspect the invention relates to a friction brake assembly for a winch for use in removing vehicle window elements and having winch operating means and a ratchet
10 mechanism blocking rotation thereof and of an associated cutting wire spool in a winch unwinding direction being opposite to a winch winding direction. In a basic configuration the friction brake assembly has a brake pad for fitting onto and substantially fully encircling the winch operating means and a ratchet release member for engaging and deactivating a winch ratchet mechanism when the brake pad is fitted onto the winch operating means.

15

The basic inventive configurations present the advantages of:

- permitting selective adjustment of the tensioning of the cutting wire; thereby
- enabling maintaining positive cutting properties during operation;
- 20 - avoiding excessive cutting wire tensioning; and thereby
- preventing cutting wire failure; and
- permitting easy winch tool repositioning without risk of uncontrolled wire unwinding.

Preferred further developments of the basic inventive idea as well as embodiments thereof
25 are specified in the dependent subclaims.

Advantages offered by the present invention, in addition to those described, will be readily appreciated upon reading the below detailed description of one embodiment of the invention.

30 **BRIEF DESCRIPTION OF THE DRAWINGS**

The invention and its further objects and advantages will be best understood by reference to the following description taken together with the accompanying drawings, in which:

Fig. 1 is an illustration of a known method of removing adhesively secured vehicle glazing;

Fig. 2 is a top plan view of a winch tool according to a first embodiment of the invention;

Fig. 3 is a side view of the winch tool of Fig. 2;

5 Fig. 4 is a plan view from above of a friction brake assembly as incorporated in the winch tool of Figs. 1 and 2;

Fig. 5 is a side view of the friction brake assembly of Fig. 4;

10 Fig. 6 is a plan view from the bottom side of an alternative embodiment of a friction brake assembly of the invention; and

Fig. 7 is a plan view from above of a double winch tool according to a second, alternative embodiment of the invention.

15

DETAILED DESCRIPTION

The invention will now be explained with reference to exemplifying embodiments thereof. In particular, a winch tool of the invention as well as a friction brake assembly for incorporation therein will be explained with reference to exemplifying embodiments that are illustrated in the accompanying drawing figures 2-6. It is emphasized that these illustrations have the
20 the single purpose of describing exemplary embodiments of the invention and are not intended to limit the invention to the details thereof. A first winch tool embodiment (Figs. 2 and 3) relates to an application of the inventive solution to a single winch tool of the known type used in pairs for removing stationary or fixed vehicle window elements. However, it shall be noted
25 that the inventive solution may be used for other specific applications requiring special additional features that are appropriate for such applications, such as different winch tool types, including winch tools supporting more than one separate winch (Fig. 7). It shall thus be realized that the invention likewise covers the incorporation of such specific application related features and any appropriate combination of features disclosed and described herein.

30

In Fig. 1 is shown an example of a prior art cutting wire winch tool 4, 5, here of the single winch type, that was generally discussed in the introduction and to which the invention may be applied. Such winch tools 4, 5 are used in pairs and each consist of one winch 6, 7 that is

used for tensioning and winding a cutting wire 3 when operated. Each of the tools 4, 5 includes two suction cups 4A, 5A with which it is secured to a window element 2. The two suction cups of each tool are interconnected by a rod-like handle 4B, 5B and are of a general design that is commonly used within this field and the operation of which need therefore not
5 be described. The cutting wire 3 is tensioned by operating the winch 6, 7 of one of the tools 4 or 5, such as by means of a wrench-like handle 14 (indicated in Fig. 1). The handle engages a winch operating means 8, 9, such as common socket that is provided at an upwardly facing side of the winch. The cutting wire 3 is tensioned to cause it to cut through adhesive bonding a window element 2 to a vehicle 1 (very schematically indicated in Fig. 1). As the wire is
10 tensioned and cuts through the adhesive it is wound up on a cutting wire spool 12, 13 to which it is secured and that is functionally fixed to an associated winch operating means 8, 9.

A ratchet or stop mechanism 10, 11 is provided for each winch 6, 7 to positively block rotation of the winch and its cutting wire spool 12, 13 in a winch or wire unwinding direction
15 L/R when the winch is no longer operated. The ratchet mechanism 10, 11 will thus prevent uncontrolled unwinding of cutting wire 3 from the spool in a direction opposite a winch or wire winding direction R/L. The ratchet mechanism has a release knob 10A, 11A that is operated to deactivate the ratchet mechanism and allow free rotation of the associated wire spool 12, 13. As was briefly discussed initially, this general type of winch tool, especially
20 when used by less experienced operators, may cause the development of such high wire tensioning that the wire 3 breaks. This does in turn cause time consuming replacement or at least repositioning of the cutting wire. Using winch tools 4, 5 of this type normally also requires quite frequent repositioning of the tools to obtain optimum cutting properties, such as cutting angles, during the entire cutting operation for removing a window element. Due to
25 the high cutting wire tensioning such winch tool repositioning may easily result in sudden unwinding of cutting wire from the wire spool of one or both winch tools during repositioning thereof.

The invention intends to solve the problems that were discussed above as well as in the
30 introduction. To overcome shortcomings and problems associated with common winch tools, a new concept is proposed for avoiding excessive cutting wire tensioning. A basic feature of the solution is the provision of means for temporary releasing the winch ratchet mechanism and for allowing adjustment of an actual cutting wire tension applied by the winches.

In Figs. 2 and 3 is shown an exemplary embodiment of the invention as applied to a winch tool 104 of the general single winch type disclosed in Fig. 1. In said drawing figures the winch tool 104 is generally shown having the single winch 6 for tensioning and winding a cutting wire when operated. The general winch tool configuration in the embodiment of Figs. 2 and 3 may be essentially identical to that illustrated in Fig. 1 and thus the different common parts are designated by the same reference numbers. Parts being unique for the invention are in those drawing figures designated by reference numbers in a 100 series.

A central feature of this winch tool 104 is a friction brake assembly 120 (see especially Figs. 4 and 5) that is attached to the winch 6 operating means 8. Such a friction brake assembly 120 may be permanently fitted to the winch operating means 8 of each of the winches used for removing a window or may preferably be removably fitted to a respective winch operating means 8 when required. The friction brake assembly 120 includes a brake pad 121 that in the fitted condition of the friction brake assembly 120 frictionally engages an exterior of the winch operating means 8. The brake pad 121 serves to frictionally resist unwinding rotation of the winch operating means 8 and of the associated cutting wire spool 12 that is caused by the tensioned cutting wire and thereby to resist unwinding of cutting wire from the wire spool 12. This frictional engagement also serves to prevent overloading of the cutting wire 3 by adjustably reducing the tensioning of the cutting wire so that it will not break.

In particular, the brake pad 121 has a generally annular shape with a central aperture 131A, 131B in which the winch operating means 8 will be received in fitted condition. In such fitted condition the brake pad 121 at least substantially fully encircles the winch operating means 8 of the winch 6. The friction brake assembly 120 also includes adjustment means 128 that initially enable fitting of the brake pad 121 onto the winch operating means 8 by expanding the central aperture 131A, 131B. The adjustment means 128 allow adjustably controlling a friction force being applied thereby to an associated winch operating means 8 to resist rotation thereof and thereby of the winch 6 and the associated cutting wire spool 12 in an unwinding direction. The adjustment is performed in fitted condition by resiliently reducing the size of the central aperture in a way that will be exemplified further below.

In the embodiment illustrated in detail in Figs. 4 and 5 the winch tool 104 friction brake assembly 120 includes a brake pad 121 having a partly annular shape for encircling, in the

fitted condition, a major part of the winch operating means 8. Specifically, the brake pad 121 of this embodiment consists of two separate halves 121A, 121B that in an assembled condition form the partly annular shape and two adjustable gaps 123A, 123B between free ends of the pad 121 halves 121A, 121B. The opposing ends 124, 126 and 125, 127 of the two
5 halves 121A, 121B are resiliently urged towards each other by said adjustment means 128.

In this embodiment the adjustment means 128 for adjustably controlling the applied friction force also serves to assemble the two brake pad halves 121A, 121B. The two brake pad halves 121A, 121B are interconnected by two setting bolts 129 each engaging two adjacent
10 ends 124, 126 and 125, 127, respectively of the brake pad 121. Expressed otherwise, the adjustment means 128 consist of setting bolts 129 that each penetrate one of the ends 124, 125 of a first brake pad half 121A having a semicircular shape. The setting bolts 129 further threadably engage respective, adjacent ends 126, 127 of a second brake pad half 121B. A
15 biasing spring 130 is provided around each setting bolt shaft 129B, between a bolt head 129A and the penetrated brake pad end 124, 125. It will be realized that unscrewing the setting bolts 129 will widen the central aperture 131A, 131B thereby reducing the frictional force applied by the friction brake assembly 120. Correspondingly, tightening of the setting bolts 129 will reduce the width of the central aperture 131A, 131B thereby resiliently increasing the frictional force applied by the friction brake assembly 120.

20

In order to frictionally resist unwinding rotation of the winch operating means 8 and thereby of the cutting wire spool 12, the friction brake assembly 120 in its fitted condition first causes deactivation of the winch ratchet mechanism 10. To achieve such ratchet mechanism 10 deactivation the winch tool 104 friction brake assembly 120 includes a ratchet release
25 member 122. The ratchet release member 122 is fixed to and supported in an extended part 121C of said otherwise generally semi-circular second brake pad half 121B. In the fitted condition of the brake assembly 120 the ratchet release member 122 is extended downwardly from the brake pad 121, towards the ratchet mechanism 10 and its release knob 10A, as will be seen in Fig. 5. It has a general pin shape with a basically U-shaped recess 122A formed in
30 the lower end portion thereof, leaving reduced side flanks 122B that in the fitted condition straddle the ratchet release knob 10A. As is conventional, the ratchet release knob 10A may be pulled out to deactivate the ratchet mechanism 10.

It should now be clear that the described embodiment of the inventive friction brake assembly is intended for cooperation with a winch 6 having a ratchet mechanism 10 that may be selectively deactivated by manual operation of a deactivation knob 10A between ratchet blocking and releasing positions. Mounting or fitting of the friction brake assembly 120 to the winch 6 is performed with the central aperture 131A, 131B expanded to fit on the winch operating means 8 and with the ratchet release member 122 side flanks 122B straddling a part of the pulled out ratchet release knob 10A (see also Fig. 6). The ratchet release knob 10A is maintained in the pulled out position deactivating the ratchet mechanism 10. The unwinding blocking function of the ratchet mechanism 10 is thus replaced by the adjustable frictional unwinding resisting function of the friction brake assembly 120. The friction brake assembly is adapted to engage the deactivation knob 10A with its ratchet release member 122 to maintain the deactivation knob in the release position deactivating the winch ratchet mechanism.

Based on the above explained embodiment of the winch tool as well as the friction brake assembly of the invention, a method of removing a window element 2 from a vehicle 1 will now be briefly described. In the common manner a cutting wire 3 is used to cut through an adhesive bonding the window element to the vehicle. Separate winches 6, 7 of one or more winch tools 4, 5 are alternately operated for tensioning and winding the same cutting wire to cut through the adhesive around the window element. The winches each have a ratchet mechanism 10, 11 for positively blocking winch rotation in a winch/wire unwinding direction being opposite to a winch/wire winding direction. In accordance with the invention the tensioning of the cutting wire caused by the operation of one winch is adjusted by temporarily deactivating the ratchet mechanism of an associated non-operated winch and by functionally replacing the ratchet mechanism by a friction brake assembly 120 resisting rotation in the unwinding direction of the non-operated winch. The friction brake assembly 120 is releasably mounted or fitted directly onto a winch operating means 8 of a winch 6, thereby engaging and deactivating the winch ratchet mechanism 10 of said winch. The resistance to rotation of this non-operated winch 6 and thereby of the tensioning of the cutting wire caused by rotation of the operated winch is adjustably controlled by resiliently adjusting the frictional force applied by the friction brake assembly 120. In this manner excessive cutting wire tensioning and associated wire breakage may be effectively eliminated, even for operators having less experience. The reduced and adjustable wire tensioning force also

essentially facilitates winch tool repositioning, avoiding unintentional and sudden wire unwinding from winch spools.

In Fig. 6 is illustrated an alternative embodiment of the friction brake assembly 220 of the invention. In this embodiment the friction brake assembly 220 is likewise intended for cooperation with a common type of winch having the same ratchet mechanism that may be selectively deactivated by manual operation of a deactivation knob between ratchet blocking and releasing positions. The friction brake assembly 220 has a brake pad 221 that is likewise adapted to be fitted onto a winch operating means with a resiliently expandable central aperture 231 thereof. In this case the brake pad with its central aperture 231 receiving the winch operating means, fully encircles the operating means except for a small gap 223 formed between free ends 224, 225 of the unitary or single brake pad part 221. Adjustment means 228 are likewise provided for adjustably controlling the friction force being applied by the friction brake assembly 220 to an associated winch operating means to resist rotation in a winch unwinding direction. In this case the adjustment means 228 includes one setting bolt 229 penetrating one 224 of the ends 224, 225 of the brake pad 221 and being threadably engaged with the adjacent end 225. Like before a biasing spring 230 is provided around the setting bolt shaft 229B, between a bolt head 229A and the penetrated brake pad end 224.

The friction brake assembly has a corresponding ratchet release member 222 that is adapted to engage and deactivate a winch ratchet mechanism with the brake pad 221 fitted onto a winch operating means. Like in the first embodiment the ratchet release member 222 has a pin shape with a recess 222A and side flanks 222B at a lower end portion thereof, so that in the fitted condition it engages the deactivation knob to maintain it in the release position.

Finally, Fig. 7 schematically illustrates an alternative embodiment where the principles of the invention are applied to a double-winch type of winch tool 304. In such an exemplary application a friction brake assembly 120 of the first embodiment may be mounted on each of the winches 6, 7 of the winch tool 304 or may be alternately fitted to the operating means 8, 9 of said winches during the different operational steps for removing a window element.

In alternative, but not specifically illustrated embodiments of the invention variations of the different illustrated parts and assemblies may be employed without departing from the scope

of the invention. As an example of this the invention may be applied to other types of winch tool configurations having other or supplementary means for securing the tool to a vehicle window or to a vehicle frame. In other words the invention is not limited to the suction cup type of tool fastener. Although the winch operating means has only been exemplified as a
5 common type of socket, it shall be emphasized that the invention covers the use thereof with different kinds of handle connectors, as long as they have a mainly rotationally symmetrical outermost wall surface for cooperation with the friction brake assembly brake pad. Likewise, as long as it performs the desired function the friction brake assembly may be designed in alternative ways, e.g. having a different number of brake pad sections than the ones
10 illustrated. The same applies to the brake pad friction force adjustment means that may be differently designed while still performing the intended function.

The invention has been described in connection with what is presently considered the most practical and preferred embodiments but it shall be understood that the invention is not
15 limited to the disclosed embodiments. It likewise covers any feasible combination of features described and illustrated herein and is therefore intended to cover various modifications and equivalent arrangements included within the spirit and scope of the appended claims.

PATENT CLAIMS

1. A method of removing a window element (2) from a vehicle (1) by cutting through an adhesive bonding the window element to the vehicle by means of a cutting wire (3), wherein
5 separate winches (6, 7) of one or more winch tools (4, 5; 104; 304) are alternately operated for tensioning and winding the same cutting wire to cut through the adhesive around the window element, said winches having a ratchet mechanism (10, 11) for positively blocking winch rotation in a winch unwinding direction (L or R) opposite a winch winding direction (R or L), **characterized by:**
- 10
- adjusting the tensioning of the cutting wire caused by the operation of one winch; by
 - temporarily deactivating a ratchet mechanism of an associated non-operated winch; and
 - functionally replacing said ratchet mechanism by a friction brake assembly (120; 220) resisting rotation in said unwinding direction (L or R) of said non-operated winch.
- 15
2. A method according to claim 1, **characterized by** fitting the friction brake assembly (120; 220) directly onto a winch operating means (8) of a winch (6), thereby engaging and deactivating the winch ratchet mechanism (10) of said winch.
- 20
3. A method according to claims 1 or 2, **characterized by** adjusting the friction brake assembly (120; 220) to adjustably control the resistance to rotation of the associated non-operated winch (6) and thereby of the tensioning of the cutting wire caused by rotation of the operated winch.
- 25
4. A winch tool (4, 5; 104; 304) having at least one winch (6, 7) for tensioning and winding a cutting wire (3) when operated, said cutting wire being tensioned and wound to cut through adhesive bonding a window element (2) to a vehicle (1), the or each winch having a ratchet mechanism (10; 11) for positively blocking rotation thereof in a winch unwinding direction (L or R) opposite a winch winding direction (R or L) and a cutting wire spool (12,
30 13) functionally fixed to a winch operating means (8, 9), **characterized by:**
- a friction brake assembly (120; 220) that fits onto the winch operating means; that
 - in the fitted condition deactivates the winch ratchet mechanism; and that includes

- a brake pad (121; 221) that in a fitted condition of the friction brake assembly frictionally engages the winch operating means resisting rotation thereof by the tensioned cutting wire and thereby resisting unwinding of cutting wire from the wire spool.

5 5. A winch tool (104; 304) according to claim 4, **characterized in** that the friction brake assembly (120; 220) includes a ratchet release member (122; 222) that engages and deactivates the winch ratchet mechanism (10) with the friction brake assembly being fitted onto the winch operating means (8) and adjustment means (128; 228) for adjusting a frictional force that is applied to the winch operating means for resisting rotation thereof.

10

6. A friction brake assembly (120; 220) for a winch (6) for use in removing vehicle window elements (2) and having winch operating means (8) and a ratchet mechanism (10) blocking rotation of the winch and an associated cutting wire spool (12) in a winch unwinding direction (L or R) being opposite to a winch winding direction (R or L),
15 **characterized by:**

- a brake pad (121; 221) for fitting onto and substantially fully encircling the winch operating means (8) of the winch (6); and
- a ratchet release member (122; 222) for engaging and deactivating the winch ratchet mechanism when the brake pad is fitted onto the winch operating means.

20

7. A friction brake assembly (120; 220) according to claim 6, **characterized by** adjustment means (128; 228) for adjustably controlling a friction force being applied thereby to an associated winch operating means (8) to resist rotation of said winch (6) in a winch unwinding direction (L or R).

25

8. A friction brake assembly (120) according to claims 6 or 7, **characterized in** that the brake pad (121; 221) has a partly annular shape for encircling, in the fitted condition, a major part of the winch operating means (8) and that at least one gap (123A, 123B; 223) is present between free ends (124, 125, 126, 127; 224, 225) of the pad, said ends being resiliently
30 moveable towards each other.

9. A friction brake assembly (120; 220) according to claims 7 or 8, **characterized in** that the adjustment means (128; 228) for adjustably controlling an applied friction force consist of

at least one setting bolt (129; 229) penetrating one of said ends (124, 125; 224) and being threadably engaged with the adjacent end (126, 127; 225) and in that a biasing spring (130) is provided around the or each setting bolt shaft (129B), between a bolt head (129A) and the penetrated brake pad end.

5

10. A friction brake assembly (120) according to claims 8 or 9, **characterized in** that the brake pad (121) consist of two separate parts (121A, 121B) that in an assembled condition form the partly annular shape and that are interconnected by two setting bolts (129) each engaging two adjacent ends (124, 126 and 125, 127, respectively) of the brake pad.

10

11. A friction brake assembly (120; 220) according to any of claims 6-10, for cooperation with a winch (6) having a ratchet mechanism (10) that may be selectively deactivated by manual operation of a deactivation knob (10A) between ratchet blocking and releasing positions, **characterized by** a ratchet release member (122; 222) being adapted to engage, in
15 the fitted condition, the deactivation knob (10A) to maintain it in the release position.

- - - -

1/4

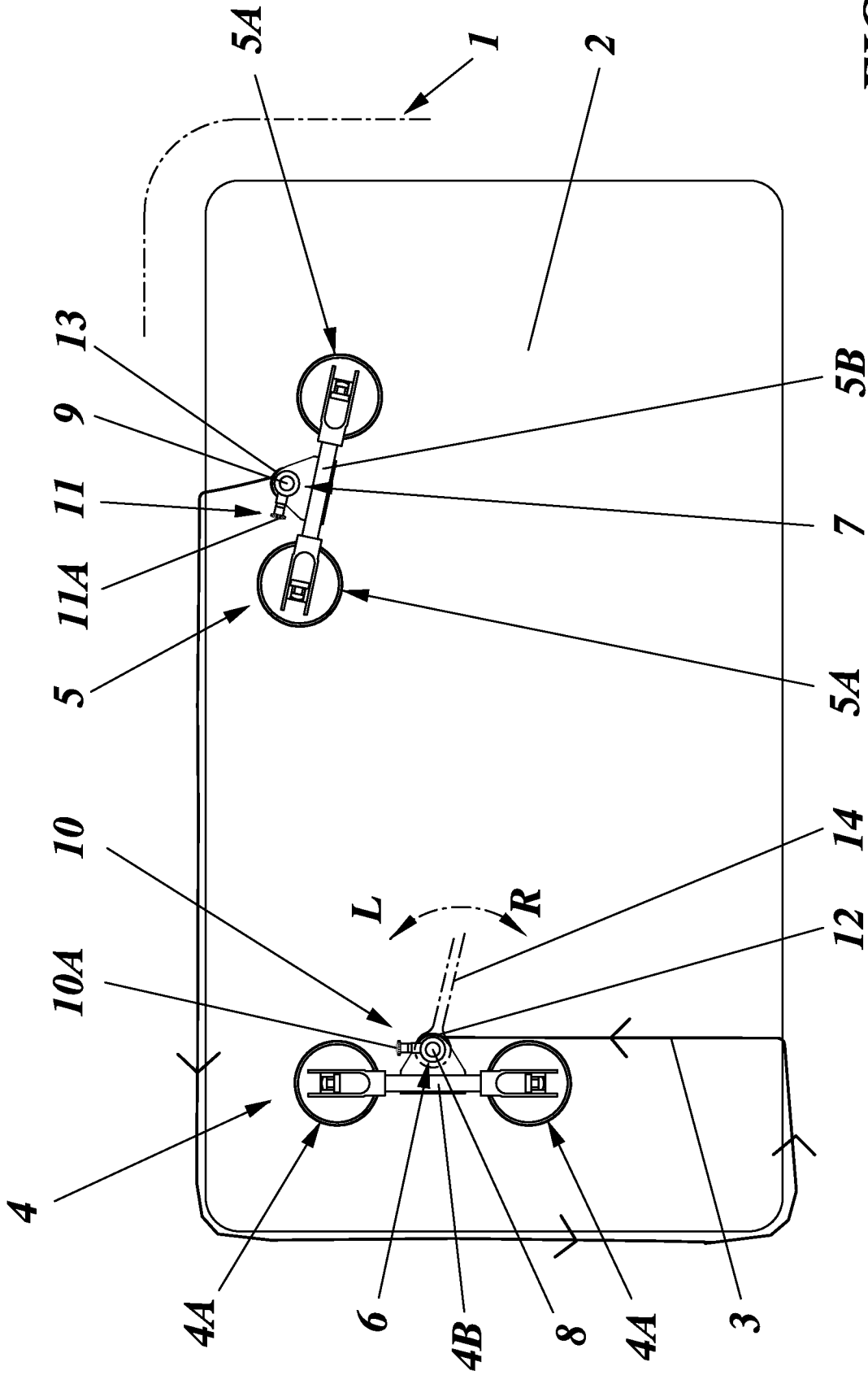

FIG. 1
PRIOR ART

FIG. 2

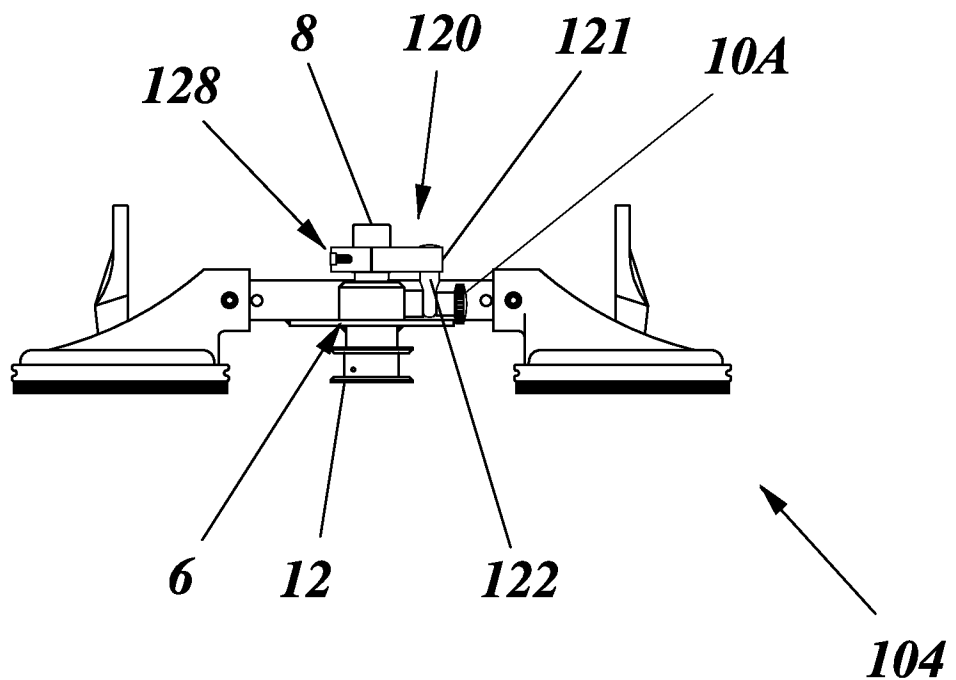
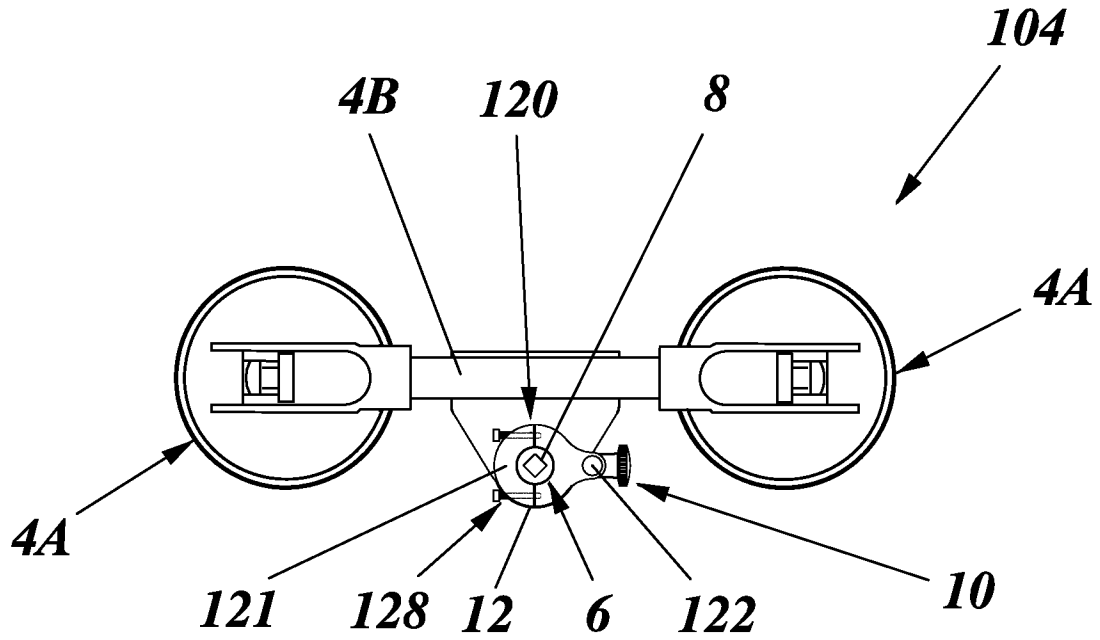

FIG. 3

FIG. 4

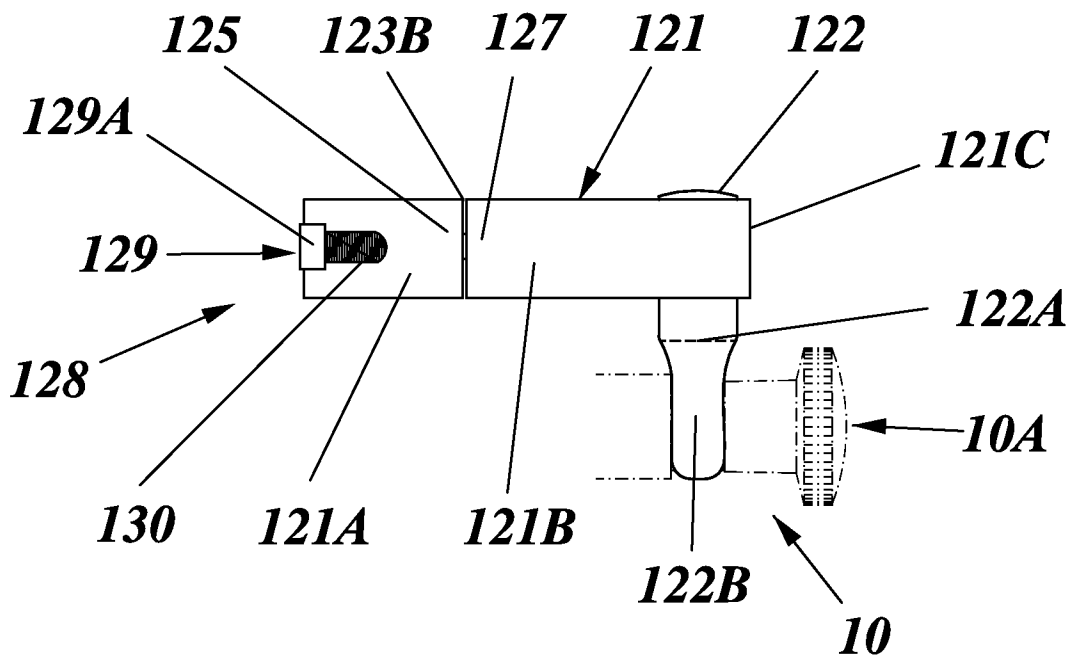
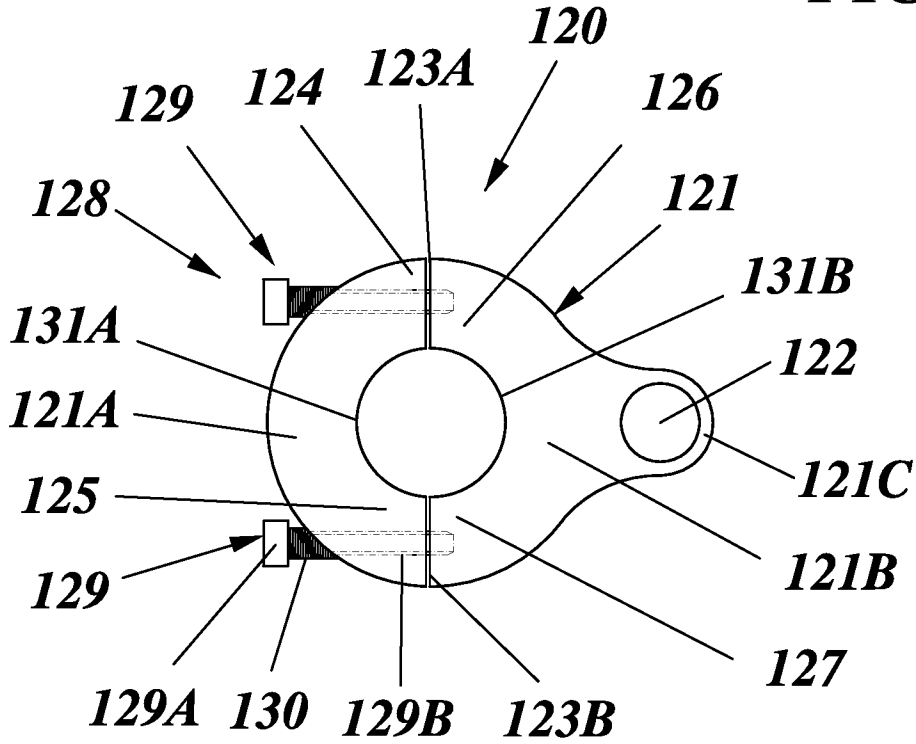

FIG. 5

FIG. 6

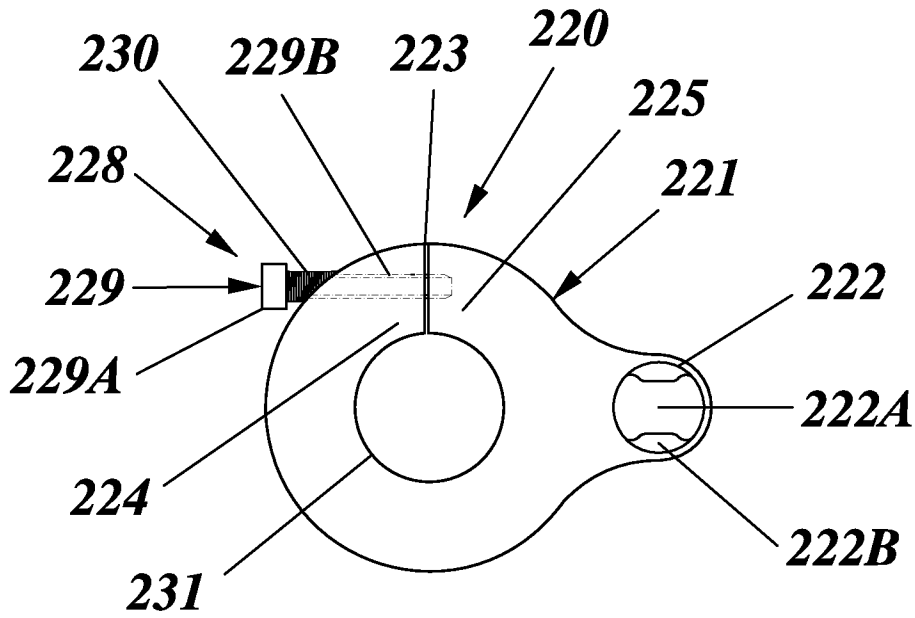
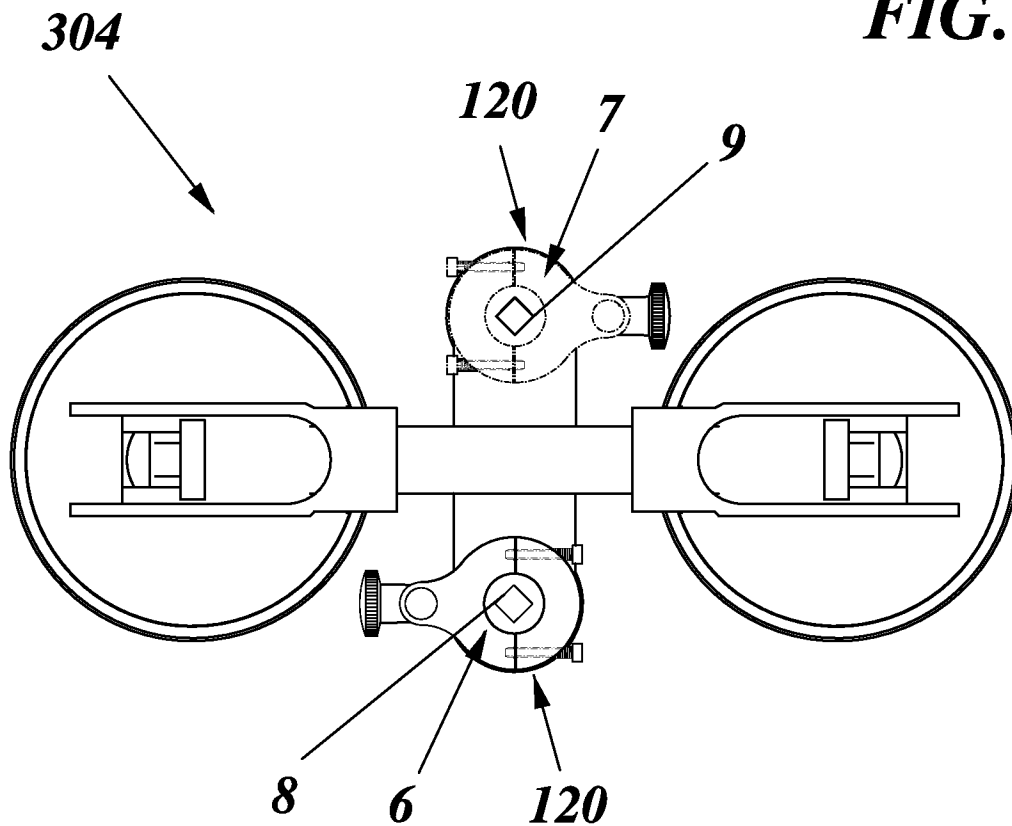

FIG. 7



INTERNATIONAL SEARCH REPORT

International application No.
PCT/SE2011/050249

A. CLASSIFICATION OF SUBJECT MATTER		
IPC: see extra sheet		
According to International Patent Classification (IPC) or to both national classification and IPC		
B. FIELDS SEARCHED		
Minimum documentation searched (classification system followed by classification symbols)		
IPC: B26B, B26D, B60J, B60S, B62D		
Documentation searched other than minimum documentation to the extent that such documents are included in the fields searched		
SE, DK, FI, NO classes as above		
Electronic data base consulted during the international search (name of data base and, where practicable, search terms used)		
EPO-Internal, PAJ, WPI data		
C. DOCUMENTS CONSIDERED TO BE RELEVANT		
Category*	Citation of document, with indication, where appropriate, of the relevant passages	Relevant to claim No.
A	WO 2004103748 A1 (RAMHUSSET DALA SPEGLAR AB ET AL), 2 December 2004 (2004-12-02); whole document --	1-11
A	WO 2004014678 A2 (MOBILGLAS 2000 APS ET AL), 19 February 2004 (2004-02-19); whole document --	1-11
A	GB 2465847 A (BELRON HUNGARY KFT ZUG BRANCH), 9 June 2010 (2010-06-09); whole document --	1-11
A	WO 2006030212 A1 (CARGLASS LUXEMBOURG SARL ZUG ET AL), 23 March 2006 (2006-03-23); whole document --	1-11
<input checked="" type="checkbox"/> Further documents are listed in the continuation of Box C. <input checked="" type="checkbox"/> See patent family annex.		
* Special categories of cited documents: "A" document defining the general state of the art which is not considered to be of particular relevance "E" earlier application or patent but published on or after the international filing date "L" document which may throw doubts on priority claim(s) or which is cited to establish the publication date of another citation or other special reason (as specified) "O" document referring to an oral disclosure, use, exhibition or other means "P" document published prior to the international filing date but later than the priority date claimed "T" later document published after the international filing date or priority date and not in conflict with the application but cited to understand the principle or theory underlying the invention "X" document of particular relevance; the claimed invention cannot be considered novel or cannot be considered to involve an inventive step when the document is taken alone "Y" document of particular relevance; the claimed invention cannot be considered to involve an inventive step when the document is combined with one or more other such documents, such combination being obvious to a person skilled in the art "&" document member of the same patent family		
Date of the actual completion of the international search		Date of mailing of the international search report
31-10-2011		14-11-2011
Name and mailing address of the ISA/SE Patent- och registreringsverket Box 5055 S-102 42 STOCKHOLM Facsimile No. + 46 8 666 02 86		Authorized officer Hans Nordström Telephone No. + 46 8 782 25 00

INTERNATIONAL SEARCH REPORT

International application No.
PCT/SE2011/050249

C (Continuation). DOCUMENTS CONSIDERED TO BE RELEVANT		
Category*	Citation of document, with indication, where appropriate, of the relevant passages	Relevant to claim No.
A	JP 2000289582 A (BIG TOOL CO LTD), 17 October 2000 (2000-10-17); (abstract) Retrieved from: PAJ database; Original document: whole document --	1-11
A	WO 8607017 A1 (FOLKSAM AUTO AB), 4 December 1986 (1986-12-04); whole document -- -----	1-11

Continuation of: second sheet

International Patent Classification (IPC)

B26B 27/00 (2006.01)

B26D 1/547 (2006.01)

B60J 1/00 (2006.01)

B60J 10/02 (2006.01)

B60S 5/00 (2006.01)

Download your patent documents at www.prv.se

The cited patent documents can be downloaded:

- From "Cited documents" found under our online services at www.prv.se
(English version)
- From "Anförda dokument" found under "e-tjänster" at www.prv.se
(Swedish version)

Use the application number as username. The password is **BALWPXOQWL**.

Paper copies can be ordered at a cost of 50 SEK per copy from PRV InterPat (telephone number 08-782 28 85).

Cited literature, if any, will be enclosed in paper form.

INTERNATIONAL SEARCH REPORT

Information on patent family members

International application No.

PCT/SE2011/050249

WO	2004103748 A1	02/12/2004	AT	465038 T	15/05/2010
			AU	2003243068 A1	13/12/2004
			CA	2525154 A1	02/12/2004
			CA	2525152 A1	02/12/2004
			DE	60332286 D1	02/06/2010
			EP	1628846 B1	21/04/2010
			EP	1628847 A1	01/03/2006
			ES	2344787 T3	07/09/2010
			JP	2006526136 A	16/11/2006
			JP	4614067 B2	19/01/2011
			US	7618023 B2	17/11/2009
			US	20070040415 A1	22/02/2007
			US	20070000361 A1	04/01/2007
			WO	2004103747 A1	02/12/2004
WO	2004014678 A2	19/02/2004	AU	2003247272 A1	25/02/2004
			EP	1534546 A2	01/06/2005
GB	2465847 A	09/06/2010	AU	2009326238 A1	17/06/2010
			CA	2745057 A1	17/06/2010
			EP	2355961 A1	17/08/2011
			US	20100139471 A1	10/06/2010
			WO	2010067046 A1	17/06/2010

INTERNATIONAL SEARCH REPORT

Information on patent family members

International application No.

PCT/SE2011/050249

WO	2006030212 A1	23/03/2006	AT	524336 T	15/09/2011
			AT	458636 T	15/03/2010
			AT	458635 T	15/03/2010
			AU	2005283924 A1	23/03/2006
			BR	PI0515277 A	15/07/2008
			CA	2579369 A1	23/03/2006
			CN	101052540 A	10/10/2007
			CN	101817297 A	01/09/2010
			DE	602005019583 D1	08/04/2010
			DE	602005019539 D1	08/04/2010
			DK	1789274 T3	10/05/2010
			DK	1714812 T3	17/05/2010
			EP	2186664 A1	19/05/2010
			ES	2339799 T3	25/05/2010
			ES	2339686 T3	24/05/2010
			HK	1096915 A1	20/05/2010
			HK	1101565 A1	20/05/2010
			JP	2010023824 A	04/02/2010
			JP	4777259 B2	21/09/2011
			JP	2007515334 A	14/06/2007
			NO	20071883 A	13/04/2007
			NZ	553639 A	31/03/2011
			RS	51234 B	31/12/2010
			RS	51208 B	31/12/2010
			US	20080017295 A1	24/01/2008
JP	2000289582 A	17/10/2000	JP	3200419 B2	20/08/2001
WO	8607017 A1	04/12/1986	DK	48687 A	30/01/1987
			NO	870342 A	28/01/1987