

(19) World Intellectual Property Organization
International Bureau



(43) International Publication Date
25 October 2007 (25.10.2007)

PCT

(10) International Publication Number
WO 2007/120807 A2

(51) International Patent Classification:
B29C 49/64 (2006.01)

(74) Agents: ERJAVAC, Stanley M. et al.; Harness, Dickey & Pierce, P.L.C., P.O. Box 828, Bloomfield Hills, Michigan 48303 (US).

(21) International Application Number:
PCT/US2007/009097

(81) Designated States (unless otherwise indicated, for every kind of national protection available): AE, AG, AL, AM, AT, AU, AZ, BA, BB, BG, BH, BR, BW, BY, BZ, CA, CH, CN, CO, CR, CU, CZ, DE, DK, DM, DZ, EC, EE, EG, ES, FI, GB, GD, GE, GH, GM, GT, HN, HR, HU, ID, IL, IN, IS, JP, KE, KG, KM, KN, KP, KR, KZ, LA, LC, LK, LR, LS, LT, LU, LY, MA, MD, MG, MK, MN, MW, MX, MY, MZ, NA, NG, NI, NO, NZ, OM, PG, PH, PL, PT, RO, RS, RU, SC, SD, SE, SG, SK, SL, SM, SV, SY, TJ, TM, TN, TR, TT, TZ, UA, UG, UZ, VC, VN, ZA, ZM, ZW.

(22) International Filing Date: 13 April 2007 (13.04.2007)

(25) Filing Language: English

(26) Publication Language: English

(30) Priority Data:
60/791,954 13 April 2006 (13.04.2006) US
11/786,736 12 April 2007 (12.04.2007) US

(63) Related by continuation (CON) or continuation-in-part (CIP) to earlier application:
US 11/786,736 (CON)
Filed on 12 April 2006 (12.04.2006)

(84) Designated States (unless otherwise indicated, for every kind of regional protection available): ARIPO (BW, GH, GM, KE, LS, MW, MZ, NA, SD, SL, SZ, TZ, UG, ZM, ZW), Eurasian (AM, AZ, BY, KG, KZ, MD, RU, TJ, TM), European (AT, BE, BG, CH, CY, CZ, DE, DK, EE, ES, FI, FR, GB, GR, HU, IE, IS, IT, LT, LU, LV, MC, MT, NL, PL, PT, RO, SE, SI, SK, TR), OAPI (BF, BJ, CF, CG, CI, CM, GA, GN, GQ, GW, ML, MR, NE, SN, TD, TG).

(71) Applicant (for all designated States except US): **AMCOR LIMITED** [AU/AU]; 679 Victoria Street, Abbotsford, Victoria 3067 (AU).

(72) Inventors; and

(75) Inventors/Applicants (for US only): **ANDISON, David** [CA/CA]; 452 Carlton Drive, Oakville, Ontario L6J 5X3 (CA). **LISCH, David, G.** [US/US]; 10010 White Tail Lane, Jackson, Michigan 49201 (US). **WEISSMANN, Dan** [US/US]; 16 Windham Drive, Simsbury, Connecticut 06070 (US).

Published:

— without international search report and to be republished upon receipt of that report

For two-letter codes and other abbreviations, refer to the "Guidance Notes on Codes and Abbreviations" appearing at the beginning of each regular issue of the PCT Gazette.

(54) Title: LIQUID OR HYDRAULIC BLOW MOLDING

(57) Abstract: An apparatus and method for simultaneously forming and filling a plastic container is provided. A mold cavity defines an internal surface and is adapted to accept a preform. A pressure source includes an inlet and a piston-like device. The piston-like device is moveable in a first direction wherein liquid is drawn into the pressure source through the inlet and in a second direction wherein the liquid is urged toward the preform. A blow nozzle may be adapted to receive the liquid from the pressure source and transfer the liquid at high pressure into the preform thereby urging the preform to expand toward the internal surface of the mold cavity and create a resultant container. The liquid remains within the container as an end product.



WO 2007/120807 A2

where ρ is the density of the PET material; ρ_a is the density of pure amorphous PET material (1.333 g/cc); and ρ_c is the density of pure crystalline material (1.455 g/cc). Once a container has been blown, a commodity may be filled into the container.

5 **[0005]** Traditionally blow molding and filling have developed as two independent processes, in many cases operated by different companies. In order to make bottle filling more cost effective, some fillers have moved blow molding in house, in many cases integrating blow molders directly into their filling lines. The equipment manufacturers have recognized this advantage and are
10 selling "integrated" systems that are designed to insure that the blow molder and the filler are fully synchronized. Despite the efforts in bringing the two processes closer together, blow molding and filling continue to be two independent, distinct processes. As a result, significant costs may be incurred while performing these two processes separately. Thus, there is a need for a liquid or hydraulic blow
15 molding system suitable for forming and filling a container in a single operation.

SUMMARY

[0006] Accordingly, the present disclosure provides a system and method for using the final liquid product to impart the pressure required to
20 expand a hot preform and to take on the shape of a mold thus simultaneously forming and filling the container.

[0007] In one example, the system includes a mold cavity defining an internal surface and adapted to accept a preform. The system also includes a pressure source having an inlet, a filling cylinder and a piston-like device. The
25 piston-like device is moveable within the filling cylinder in a first direction such that liquid is drawn into the filling cylinder through the inlet and in a second direction such that the liquid is urged toward the preform. A blow nozzle may be adapted to receive the liquid from the pressure source and transfer the liquid at
30 high pressure into the preform thereby urging the preform to expand toward the internal surface of the mold cavity and create a resultant container. The liquid remains within the container as an end commodity.

[0008] Additional benefits and advantages of the present disclosure will become apparent to those skilled in the art to which the present disclosure

relates from the subsequent description and the appended claims, taken in conjunction with the accompanying drawings.

BRIEF DESCRIPTION OF THE DRAWINGS

5 **[0009]** FIG. 1 is a schematic depiction of a heated preform passed into a mold station wherein a pressure source including a piston-like device begins to move upward, drawing liquid into the pressure source in accordance with the teachings of the present disclosure.

10 **[0010]** FIG. 2 is a schematic depiction of the system illustrated in FIG. 1 wherein the mold halves close around the preform and liquid continues to accumulate in the pressure source.

[0011] FIG. 3 is a schematic depiction of the system illustrated in FIG. 2 wherein a stretch rod extends into the preform to initiate mechanical stretching and wherein fluid continues to accumulate in the pressure source.

15 **[0012]** FIG. 4 is a schematic depiction of the system of FIG. 3 wherein the stretch rod stretches the preform and wherein fluid has been fully accumulated in the pressure source.

20 **[0013]** FIG. 5 is a schematic depiction of the system of FIG. 4 wherein the piston-like device drives the liquid from the pressure source to the preform thereby expanding the preform toward the walls of the mold cavity.

[0014] FIG. 6 is a schematic depiction of the system of FIG. 5 wherein the piston-like device has been fully actuated thereby completely transferring an appropriate volume of liquid to the newly formed container and wherein the stretch rod is withdrawing; and

25 **[0015]** FIG. 7 is a schematic depiction of the system of FIG. 6 wherein the mold halves separate and the piston-like device begins to draw liquid into the pressure source in preparation for the next cycle.

DETAILED DESCRIPTION

30 **[0016]** The following description is merely exemplary in nature, and is in no way intended to limit the disclosure or its application or uses.

[0017] With reference to all Figures, a mold station according to the present teachings is shown and generally referred to as reference numeral 10.

FIGS. 1-7 show one exemplary sequence according to the present teachings. As will become appreciated from the following description, the mold station 10 and associated method utilize a final liquid commodity L to impart the pressure required to expand a hot preform 12 to take on the shape of a mold thus simultaneously forming and filling the resultant container C (FIG. 7).

[0018] With initial reference to FIG. 1, the mold station 10 will be described in greater detail. The mold station 10 generally includes a mold cavity 16, a pressure source 20, a blow nozzle 22 and a stretch rod 26. The exemplary mold cavity 16 illustrated includes mold halves 30, 32 that cooperate to define an interior surface 34 corresponding to a desired outer profile of a blown container. The mold cavity 16 may be moveable from an open position (FIG. 1) to a closed position (FIG. 2) such that a support ring 38 of the preform 12 is captured at an upper end of the mold cavity 16. The preform 12 may be formed of a polyester material, such as polyethylene terephthalate (PET), having a shape well known to those skilled in the art similar to a test-tube with a generally cylindrical cross section and a length typically approximately fifty percent (50%) that of the resultant container C height. The support ring 38 may be used to carry or orient the preform 12 through and at various stages of manufacture. For example, the preform 12 may be carried by the support ring 38, the support ring 38 may be used to aid in positioning the preform 12 in the mold cavity 16, or an end consumer may use the support ring 38 to carry the plastic container C once manufactured.

[0019] In one example, the pressure source 20 can be in the form of, but not limited to, a filling cylinder, manifold or chamber 42 that generally includes a mechanical piston-like device 40 including, but not limited to, a piston, a pump (such as a hydraulic pump) or any other such similarly suitable device, moveable within the filling cylinder, manifold or chamber 42. The pressure source 20 has an inlet 46 for accepting liquid commodity L and an outlet 48 for delivering the liquid commodity L to the blow nozzle 22. It is appreciated that the inlet 46 and the outlet 48 may have valves incorporated thereat. The piston-like device 40 may be moveable in a first direction (upward as viewed in the FIGS.) to draw liquid commodity L from the inlet 46 into the filling cylinder, manifold or chamber 42, and in a second direction (downward as viewed in the FIGS.) to

deliver the liquid commodity L from the filling cylinder, manifold or chamber 42 to the blow nozzle 22. The piston-like device 40 can be moveable by any suitable method such as pneumatically, mechanically or hydraulically for example. The inlet 46 of the pressure source 20 may be connected, such as by tubing or piping to a reservoir or container (not shown) which contains the final liquid commodity L. It is appreciated that the pressure source 20 may be configured differently.

[0020] The blow nozzle 22 generally defines an inlet 50 for accepting the liquid commodity L from the outlet 48 of the pressure source 20 and an outlet 56 (FIG. 1) for delivering the liquid commodity L into the preform 12. It is appreciated that the outlet 56 may define a shape complementary to the preform 12 near the support ring 38 such that the blow nozzle 22 may easily mate with the preform 12 during the forming/filling process. In one example, the blow nozzle 22 may define an opening 58 for slidably accepting the stretch rod 26 used to initiate mechanical stretching of the preform 12.

[0021] In one example, the liquid commodity L may be introduced into the plastic container C during a thermal process, typically a hot-fill process. For hot-fill bottling applications, bottlers generally fill the plastic container C with a liquid or product at an elevated temperature between approximately 185°F to 205°F (approximately 85°C to 96°C) and seal the plastic container C with a closure (not illustrated) before cooling. In one configuration, the liquid may be continuously circulated within the filling cylinder, manifold or chamber 42 through the inlet 46 whereby the liquid can be heated to a preset temperature (i.e., at a heat source (not illustrated) upstream of the inlet 46). In addition, the plastic container C may be suitable for other high-temperature pasteurization or retort filling processes, or other thermal processes as well. In another example, the liquid commodity L may be introduced into the plastic container C under ambient or cold temperatures. Accordingly, by way of example, the plastic container C may be filled at ambient or cold temperatures such as between approximately 32°F to 90°F (approximately 0°C to 32°C), and more preferably at approximately 40°F (approximately 4.4°C).

[0022] With reference now to all Figures, an exemplary method of simultaneously forming and filling the plastic container C will be described. At the outset, the preform 12 may be placed into the mold cavity 16. In one

example, a machine (not illustrated) places the preform 12 heated to a temperature between approximately 190°F to 250°F (approximately 88°C to 121°C) into the mold cavity 16. As the preform 12 is located into the mold cavity 16, the piston-like device 40 of the pressure source 20 may begin to draw liquid commodity L into the filling cylinder, manifold or chamber 42 through the inlet 46. The mold halves 30, 32 of the mold cavity 16 may then close thereby capturing the preform 12 (FIG. 2). The blow nozzle 22 may form a seal at a finish of the preform 12. The mold cavity 16 may be heated to a temperature between approximately 250°F to 350°F (approximately 93°C to 177°C) in order to impart increased crystallinity levels within the resultant container C. In another example, the mold cavity 16 may be provided at ambient or cold temperatures between approximately 32°F to 90°F (approximately 0°C to 32°C). Liquid commodity L may continue to be drawn into the filling cylinder, manifold or chamber 42 by the piston-like device 40.

[0023] Turning now to FIG. 3, the stretch rod 26 may extend into the preform 12 to initiate mechanical stretching. At this point, the liquid commodity L may continue to be drawn into the filling cylinder, manifold or chamber 42. With reference to FIG. 4, the stretch rod 26 continues to stretch the preform 12 thereby thinning the sidewalls of the preform 12. The volume of liquid commodity L in the filling cylinder, manifold or chamber 42 may increase until the appropriate volume suitable to form and fill the resultant container C is reached. At this point, a valve disposed at the inlet 46 of the pressure source 20 may be closed.

[0024] With specific reference to FIG. 5, the piston-like device 40 may begin to drive downward (drive phase) to initiate the rapid transfer of liquid commodity L from the filling cylinder, manifold or chamber 42 to the preform 12. Again, the piston-like device 40 may be actuated by any suitable means such as pneumatic, mechanical and/or hydraulic pressure. In one example, the hydraulic pressure within the preform 12 may reach between approximately 100 PSI to 600 PSI. The liquid commodity L causes the preform 12 to expand toward the interior surface 34 of the mold cavity 16. Residual air may be vented through a passage 70 defined in the stretch rod 26 (FIG. 5). As shown in FIG. 6, the piston-like device 40 has completed its drive phase thereby completely

transferring the appropriate volume of liquid commodity L to the newly formed plastic container C. Next, the stretch rod 26 may be withdrawn from the mold cavity 16 while continuing to vent residual air. The stretch rod 26 may be designed to displace a predetermined volume of liquid commodity L when it is withdrawn from the mold cavity 16 thereby allowing for the desired fill level of liquid commodity L within the resultant plastic container C. Generally, the desired fill level will correspond at or near the level of the support ring 38 of the plastic container C.

5
10
15
20
25

[0025] Alternatively, liquid commodity L can be provided at a constant pressure or at different pressures during the molding cycle. For example, during axial stretching of the preform 12, liquid commodity L may be provided at a pressure which is less than the pressure applied when the preform 12 is blown into substantial conformity with the interior surface 34 of the mold cavity 16 defining the final configuration of the plastic container C. This lower pressure P_1 may be ambient or greater than ambient but less than the subsequent high pressure P_2 . The preform 12 is axially stretched in the mold cavity 16 to a length approximating the final length of the resultant plastic container C. During or just after stretching the preform 12, the preform 12 is generally expanded radially outward under the low pressure P_1 . This low pressure P_1 is preferably in the range of between approximately 100 PSI to 150 PSI. Subsequently, the preform 12 is further expanded under the high pressure P_2 such that the preform 12 contacts the interior surface 34 of the mold halves 30, 32 thereby forming the resultant plastic container C. Preferably, the high pressure P_2 is in the range of approximately 500 PSI to 600 PSI. As a result of the above method, the base and contact ring of the resultant plastic container C is fully circumferentially formed.

30

[0026] Optionally, more than one piston-like device may be employed during the formation of the resultant plastic container C. For example, a primary piston-like device may be used to generate the low pressure P_1 to initially expand the preform 12 while a secondary piston-like device may be used to generate the subsequent high pressure P_2 to further expand the preform 12 such that the preform 12 contacts the interior surface 34 of the mold halves 30, 32 thereby forming the resultant plastic container C.

[0027] With reference to FIG. 7, the fill cycle is shown completed. The mold halves 30, 32 may separate and the blow nozzle 22 may be withdrawn. The resultant filled plastic container C is now ready for post-forming steps such as capping, labeling and packing. At this point, the piston-like device
5 40 may begin the next cycle by drawing liquid commodity L through the inlet 46 of the pressure source 20 in preparation for the next fill/form cycle. While not specifically shown, it is appreciated that the mold station 10 may include a controller for communicating signals to the various components. In this way, components such as, but not limited to, the mold cavity 16, the blow nozzle 22,
10 the stretch rod 26, the piston-like device 40 and various valves may operate according to a signal communicated by the controller. It is also contemplated that the controller may be utilized to adjust various parameters associated with these components according to a given application.

[0028] Some additional advantages realized by the present
15 teachings will now be discussed further.

[0029] The combination of both the blow and filling processes into one piece of equipment (mold station 10) may reduce handling parts and therefore lead to reduced capital cost per resultant plastic container C. In addition, the space required by a process that simultaneously blows and fills the
20 resultant plastic container C may be significantly reduced over the space required when the processes are separate. This may also result in lower infrastructure cost.

[0030] Integrating the two processes into a single step may reduce labor and additional costs (both capital and expense) associated with handling
25 bottles after they are produced and before they are filled.

[0031] Integrating the blowing and filling processes into a single process eliminates the need to ship bottles. The shipping of bottles is inherently inefficient and expensive. Shipping preforms, on the other hand, is much more efficient. In one example, a trailer load of empty 500 ml water bottles contains
30 approximately 100,000 individual bottles. The same size trailer loaded with preforms required to make 500 ml water bottles will carry approximately 1,000,000 individual preforms, a 10:1 improvement.

[0032] Compressed air is a notoriously inefficient means of transferring energy. Using the final product to provide hydraulic pressure to blow the container will require the equivalent of a positive displacement pump. As a result, it is a much more efficient way to transfer energy.

5 **[0033]** In the exemplary method described herein, the preforms may be passed through an oven in excess of 212°F (100°C) and immediately filled and capped. In this way, the opportunity for an empty container to be exposed to the environment where it might become contaminated is greatly reduced. As a result, the cost and complexity of aseptic filling may be greatly
10 reduced.

[0034] In some instances where products are hot filled, the package must be designed to accommodate the elevated temperature that it is exposed to during filling and the resultant internal vacuum it is exposed to as a result of the product cooling. A design that accommodates such conditions may
15 require added container weight. Liquid/hydraulic blow molding offers the potential of eliminating the hot fill process and as a result, lowering the package weight.

[0035] The process described herein may eliminate intermediary work in process and therefore may avoid the cost associated with warehousing
20 and/or container silos and/or forklifts and/or product damage, etc. In addition, without work in process inventory, the overall working capital may be reduced.

[0036] As blowing and filling are integrated closer but remain as two separate processes (such as conventional methods of forming and subsequently filling), the overall efficiency of such a system is the product of the
25 individual efficiencies of the two parts. The individual efficiencies may be driven largely by the number of transitions as parts move through the machines. Integrating the two processes into one may provide the opportunity to minimize the number of transitions and therefore increase the overall process efficiency.

[0037] Many beverages, including juices, teas, beer, etc., are
30 sensitive to oxygen and need to be protected when packaged. Many plastics do not have sufficient barrier characteristics to protect the contents from oxygen during the life of the packaged product. There are a number of techniques used to impart additional barrier properties to the container to slow down oxygen

transmission and therefore protect the package contents. One of the most common techniques is to use an oxygen scavenger in the bottle wall. Such a scavenger may be molded directly into the preform. The relatively thick wall of the preform protects the scavenger from being consumed prior to blowing it into a container. However, once the container has been blown, the surface area of the wall increases and the thickness decreases. As such, the path that the oxygen has to travel to contact and react with the active scavenging material is much shorter. Significant consumption of oxygen scavengers may begin as soon as the container is blown. If the container is formed and filled at the same time, then the scavenger is protecting the product through its entire useful life and not being consumed while the container sits empty waiting to be filled.

[0038] The method described herein may be particularly useful for filling applications such as isotonic, juice, tea and other commodities that are susceptible to biological contamination. As such, these commodities are typically filled in a controlled, sterile environment. Commercially, two ways are typically used to achieve the required sterile environment. In Europe, one primary method for filling these types of beverages is in an aseptic filling environment. The filling operation is performed in a clean room. All of the components of the product including the packaging must be sterilized prior to filling. Once filled, the product may be sealed until it is consumed preventing any potential for the introduction of bacteria. The process is expensive to install and operate. As well, there is always the risk of a bacterial contaminant breaking through the operational defenses and contaminating the product.

[0039] In North America, one predominant method for filling contaminant susceptible beverages is through hot filling. In this process, the beverage is introduced to the container at a temperature that will kill any bacteria that is present. The container may be sealed while the product is hot. One drawback to this technology is that the containers usually need to be heavy to sustain the elevated filling temperature and the vacuum that eventually develops in the container as the product cools. As well, the blow process is somewhat more complex and therefore more costly than non-heat set blow molding. The disclosure described herein offers the opportunity to dramatically reduce the cost and complexity of filling sensitive foods and beverages. By combining the

blowing and filling processes, there is an ability to heat the preform to over 212°F (100°C) for a sufficient period of time necessary to kill any biological contaminants. If a sterile product is used as the container forming medium and then immediately sealed, the process may result in a very inexpensive aseptic
5 filling process with very little opportunity for contamination.

[0040] There are many other bottled products where this technology may be applicable. Products such as dairy products, liquor, household cleaners, salad dressings, sauces, spreads, syrups, edible oils, personal care items, and others may be bottled utilizing such methods. Many of
10 these products are currently in blow molded PET containers but are also in extrusion molded plastic containers, glass bottles and/or cans. This technology has the potential of dramatically changing the economics of package manufacture and filling.

[0041] While much of the description has focused on the production
15 of PET containers, it is contemplated that other polyolefin materials (e.g., polyethylene, polypropylene, etc.) as well as a number of other plastics may be processed using the teachings discussed herein.

[0042] While the above description constitutes the present
20 disclosure, it will be appreciated that the disclosure is susceptible to modification, variation and change without departing from the proper scope and fair meaning of the accompanying claims.

CLAIMS

What is claimed is:

1. A system for simultaneously forming and filling a container comprising:

5 a mold cavity defining an internal surface and adapted to accept a preform;

a pressure source having an inlet, a chamber and a piston-like device moveable within the chamber in a first direction wherein liquid is drawn into the chamber through the inlet and in a second direction wherein the liquid is urged
10 toward the preform; and

a blow nozzle adapted to receive the liquid from the pressure source and transfer the liquid at a pressure into the preform thereby urging the preform to expand toward the internal surface of the mold cavity and create a resultant container, wherein the liquid remains within the container as an end product.

15

2. The system for simultaneously forming and filling a container according to Claim 1 wherein the piston-like device is one of a piston, and a pump and an accumulator.

20

3. The system for simultaneously forming and filling a container according to Claim 1 wherein the blow nozzle defines a shape adapted to form a seal with a finish of the preform.

25

4. The system for simultaneously forming and filling a container according to Claim 1 wherein the liquid is transferred into the preform during a hot-fill process.

30

5. The system for simultaneously forming and filling a container according to Claim 4 wherein the liquid is transferred into the preform at a temperature between approximately 185°F (85°C) and 205°F (96°C).

6. The system for simultaneously forming and filling a container according to Claim 1 wherein the liquid is transferred into the preform at an ambient temperature.

5 7. The system for simultaneously forming and filling a container according to Claim 6 wherein the liquid is transferred into the preform at a temperature between approximately 32°F (0°C) and 90°F (32°C).

10 8. The system for simultaneously forming and filling a container according to Claim 1 wherein the mold cavity accepts a preform heated to a temperature between approximately 190°F (88°C) and 250°F (121°C).

15 9. The system for simultaneously forming and filling a container according to Claim 1 wherein the mold cavity is heated to a temperature between approximately 250°F (93°C) and 350°F (177°C).

20 10. The system for simultaneously forming and filling a container according to Claim 1 wherein the liquid is transferred into the preform at a pressure between approximately 100 PSI and 600 PSI.

25 11. The system for simultaneously forming and filling a container according to Claim 1, further comprising a stretch rod adapted to extend into the preform and mechanically stretch the preform prior to the liquid being urged into the preform.

12. The system for simultaneously forming and filling a container according to Claim 11 wherein the stretch rod is vented to atmosphere.

30 13. The system for simultaneously forming and filling a container according to Claim 1 wherein the preform is initially expanded outwardly under a first pressure and subsequently expanded outwardly under a second pressure, the second pressure being greater than the first pressure.

14. The system for simultaneously forming and filling a container according to Claim 13 wherein the first pressure is between approximately 100 PSI and 150 PSI, and the second pressure is between approximately 500 PSI and 600 PSI.

5

15. The system for simultaneously forming and filling a container according to Claim 14 wherein the piston-like device comprises a first piston-like device that generates the first pressure and a second piston-like device that generates the second pressure.

10

16. A system for simultaneously forming and filling a container comprising:

a mold cavity defining an internal surface and adapted to accept a preform;

15

a pressure source adapted to urge liquid toward the preform; and

a blow nozzle adapted to receive the liquid from the pressure source and transfer the liquid at a pressure into the preform thereby urging the preform to expand toward the internal surface of the mold cavity and create a resultant container, wherein the liquid remains within the container as an end product.

20

17. The system for simultaneously forming and filling a container according to Claim 16 wherein the pressure source includes a piston-like device moveable within the pressure source in a first direction wherein liquid is drawn into the pressure source through an inlet and in a second direction wherein the liquid is urged toward the preform.

25

18. The system for simultaneously forming and filling a container according to Claim 17 wherein the piston-like device is one of a piston, and a pump and an accumulator.

30

19. The system for simultaneously forming and filling a container according to Claim 16 wherein the liquid is transferred into the preform at a temperature between approximately 185°F (85°C) and 205°F (96°C).

20. The system for simultaneously forming and filling a container according to Claim 16 wherein the liquid is transferred into the preform at a temperature between approximately 32°F (0°C) and 90°F (32°C).

5

21. The system for simultaneously forming and filling a container according to Claim 16 wherein the mold cavity accepts a preform heated to a temperature between approximately 190°F (88°C) and 250°F (121°C).

10

22. The system for simultaneously forming and filling a container according to Claim 16 wherein the mold cavity is heated to a temperature between approximately 250°F (93°C) and 350°F (177°C).

15

23. The system for simultaneously forming and filling a container according to Claim 16 wherein the liquid is transferred into the preform at a pressure between approximately 100 PSI and 600 PSI.

20

24. The system for simultaneously forming and filling a container according to Claim 16, further comprising a stretch rod adapted to extend into the preform and mechanically stretch the preform prior to the liquid being urged into the preform.

25

25. A method of simultaneously forming and filling a container comprising:

30

locating a preform in a mold cavity having an internal surface;
sealably connecting a blow nozzle onto an opening of the preform;
accumulating liquid into a chamber; and
delivering the liquid from the chamber, through the blow nozzle into the opening of the preform thereby urging the preform to expand toward the internal surface of the mold cavity and create a resultant container, wherein the liquid remains within the container as an end product.

26. The method of simultaneously forming and filling a container of Claim 25 wherein delivering the liquid from the chamber includes transferring the liquid into the preform at a temperature between approximately 185°F (85°C) and 205°F (96°C).

5

27. The method of simultaneously forming and filling a container of Claim 25 wherein delivering the liquid from the chamber includes transferring the liquid into the preform at an ambient temperature.

10

28. The method of simultaneously forming and filling a container of Claim 25 wherein delivering the liquid from the chamber includes transferring the liquid into the preform at a temperature between approximately 32°F (0°C) and 90°F (32°C).

15

29. The method of simultaneously forming and filling a container of Claim 25 wherein delivering the liquid from the chamber includes transferring the liquid into the preform, wherein the preform is heated to a temperature between approximately 190°F (88°C) and 250°F (121°C).

20

30. The method of simultaneously forming and filling a container of Claim 25 wherein locating the preform in the mold cavity includes locating the preform in a mold cavity that is heated to a temperature between approximately 250°F (93°C) and 350°F (177°C).

25

31. The method of simultaneously forming and filling a container of Claim 25 wherein delivering the liquid from the chamber includes transferring the liquid into the preform at a pressure between approximately 100 PSI and 600 PSI.

30

32. The method of simultaneously forming and filling a container of Claim 25, further comprising advancing a stretch rod into the preform thereby mechanically stretching the preform prior to the liquid being urged into the preform.

33. The method of simultaneously forming and filling a container of Claim 32 wherein advancing the stretch rod into the preform includes venting residual air in the preform through a passage defined in the stretch rod.

5 34. The method of simultaneously forming and filling a container of Claim 31 wherein delivering the liquid from the chamber comprises:
 transferring the liquid at a first pressure; and
 subsequently transferring the liquid at a second pressure, the second
10 pressure being greater than the first pressure.

10 35. The method of simultaneously forming and filling a container of Claim 34 wherein the first pressure is between approximately 100 PSI and 150 PSI,
 and the second pressure is between approximately 500 PSI and 600 PSI.

15 36. The method of simultaneously forming and filling a container of Claim 35 wherein the first pressure is generated from a first piston-like device and the second pressure is generated from a second piston-like device.

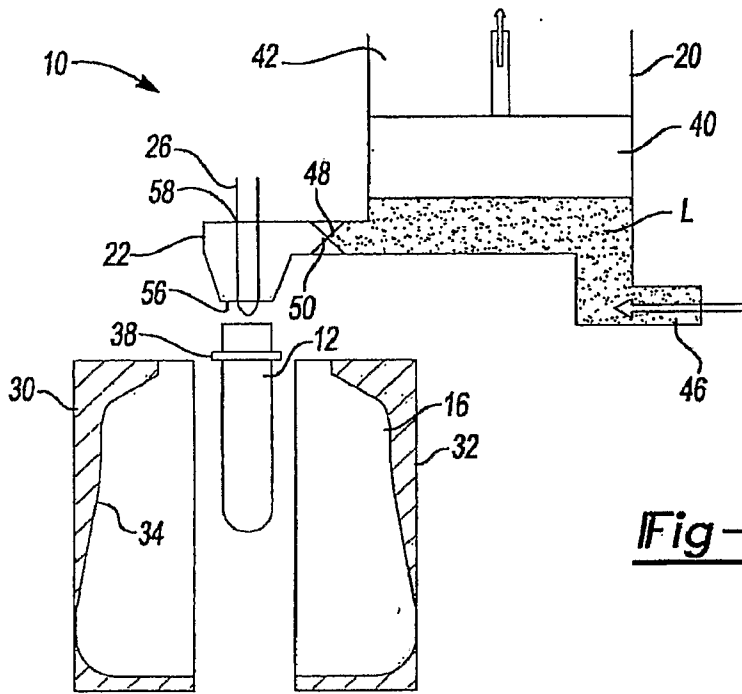

Fig-1

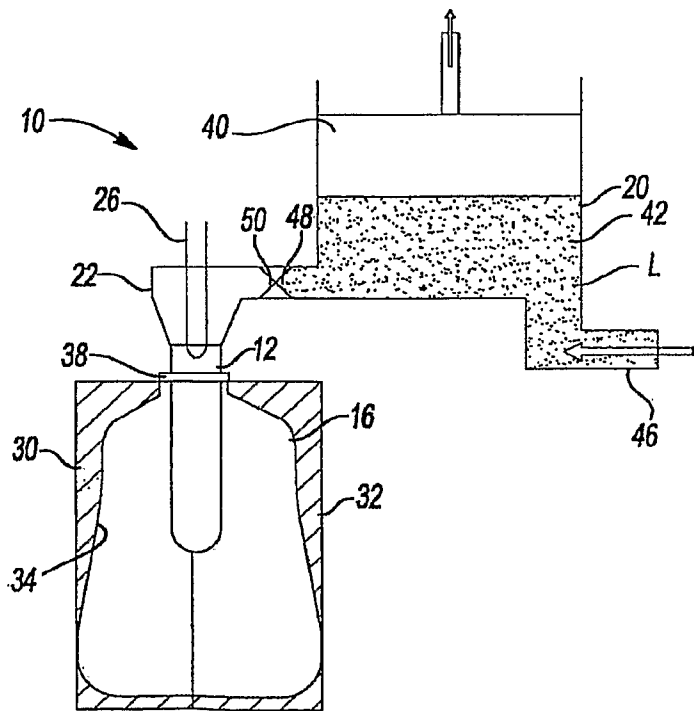

Fig-2

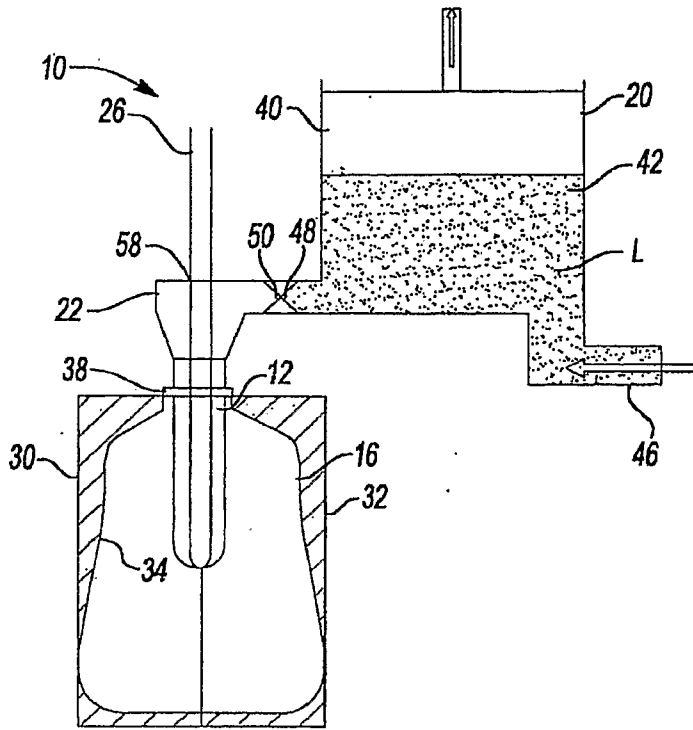

Fig-3

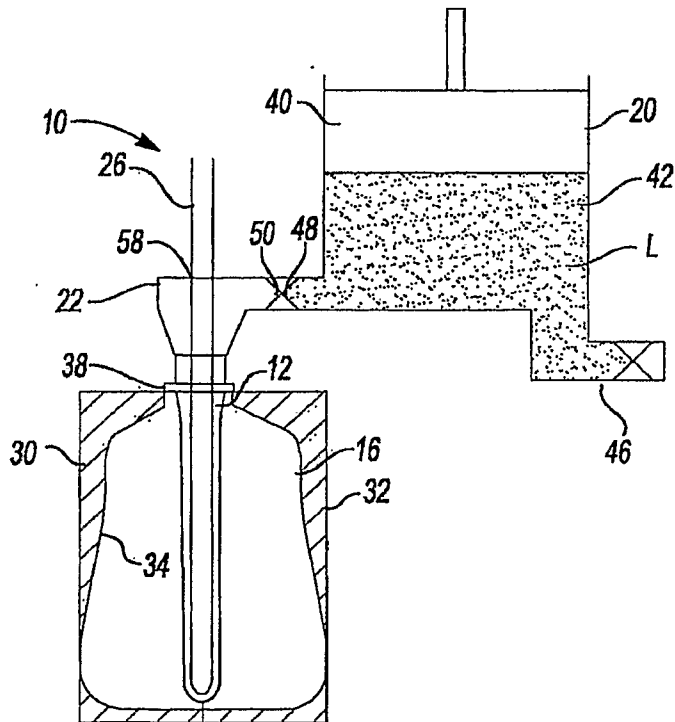

Fig-4

3/4

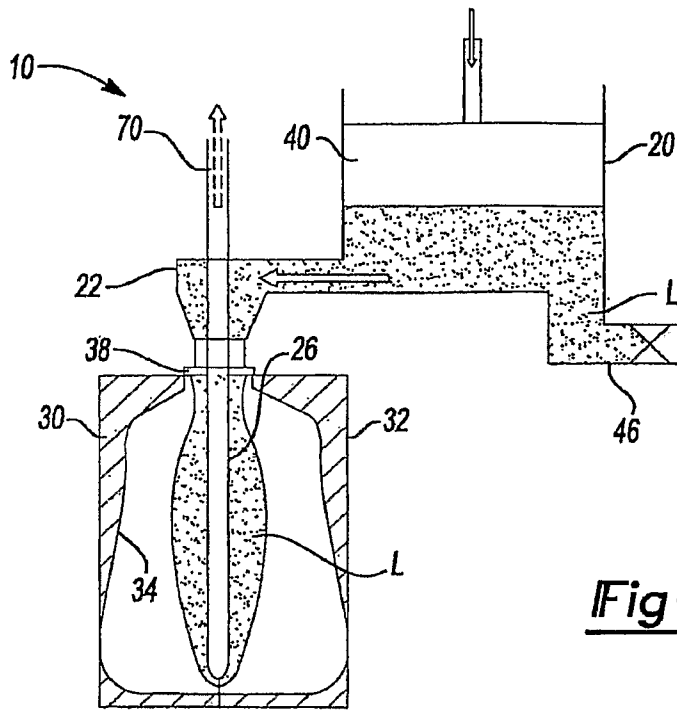

Fig-5

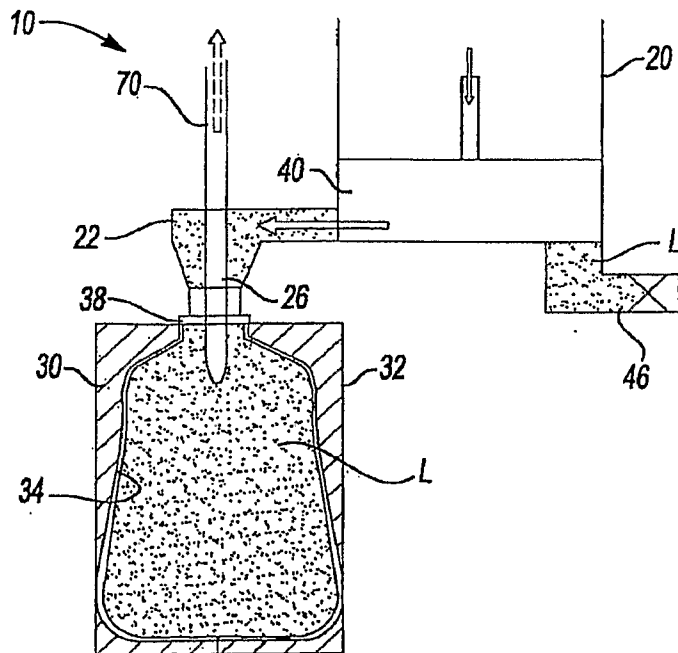

Fig-6

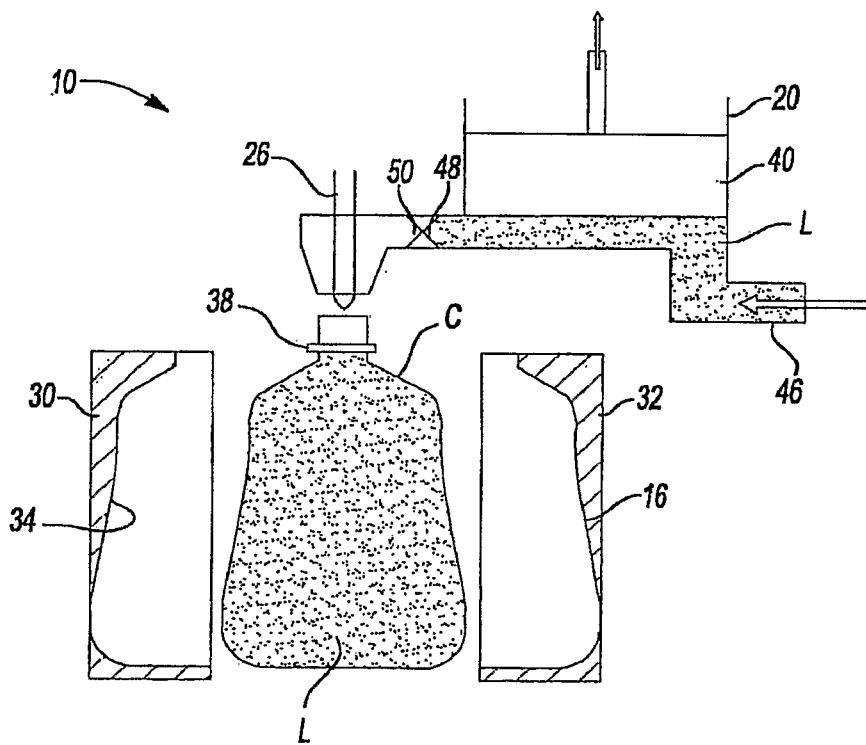

Fig-7