

(19) World Intellectual Property Organization  
International Bureau



(43) International Publication Date  
21 April 2005 (21.04.2005)

PCT

(10) International Publication Number  
WO 2005/035197 A1

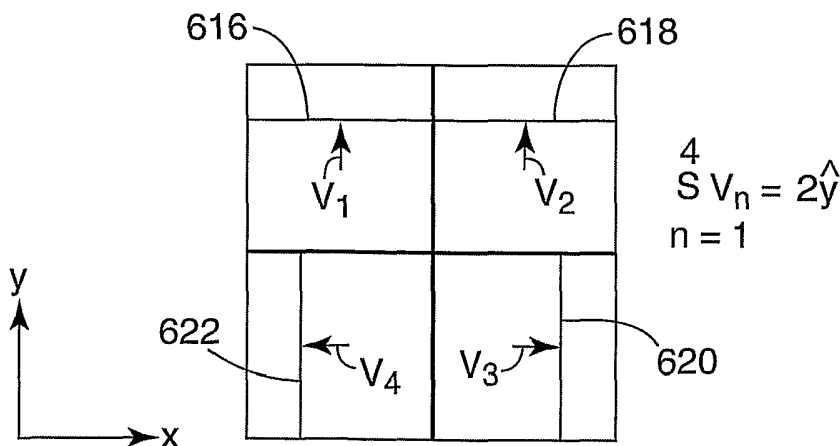
- (51) International Patent Classification<sup>7</sup>: B24D 11/00
- (21) International Application Number: PCT/US2004/024137
- (22) International Filing Date: 27 July 2004 (27.07.2004)
- (25) Filing Language: English
- (26) Publication Language: English
- (30) Priority Data:  
10/668,411 23 September 2003 (23.09.2003) US
- (71) Applicant (for all designated States except US): 3M INNOVATIVE PROPERTIES COMPANY [US/US]; 3M Center, Post Office Box 33427, Saint Paul, Minnesota 55133-3427 (US).
- (72) Inventors: CULLER, Scott R.; 3M Center, Post Office Box 33427, Saint Paul, Minnesota 55133-3427 (US). HAAS, John D.; 3M Center, Post Office Box 33427, Saint Paul, Minnesota 55133-3427 (US). SIMONS, Jeffrey R.; 3M Center, Post Office Box 33427, Saint Paul, Minnesota 55133-3427 (US).
- (74) Agents: FRANZEN, Rick L., et al.; Office of Intellectual Property Counsel, St. Paul, MN 55133-3427 (US).
- (81) Designated States (unless otherwise indicated, for every kind of national protection available): AE, AG, AL, AM, AT, AU, AZ, BA, BB, BG, BR, BW, BY, BZ, CA, CH, CN, CO, CR, CU, CZ, DE, DK, DM, DZ, EC, EE, EG, ES, FI, GB, GD, GE, GH, GM, HR, HU, ID, IL, IN, IS, JP, KE, KG, KP, KR, KZ, LC, LK, LR, LS, LT, LU, LV, MA, MD, MG, MK, MN, MW, MX, MZ, NA, NI, NO, NZ, OM, PG, PH, PL, PT, RO, RU, SC, SD, SE, SG, SK, SL, SY, TJ, TM, TN, TR, TT, TZ, UA, UG, US, UZ, VC, VN, YU, ZA, ZM, ZW.
- (84) Designated States (unless otherwise indicated, for every kind of regional protection available): ARIPO (BW, GH, GM, KE, LS, MW, MZ, NA, SD, SL, SZ, TZ, UG, ZM, ZW), Eurasian (AM, AZ, BY, KG, KZ, MD, RU, TJ, TM), European (AT, BE, BG, CH, CY, CZ, DE, DK, EE, ES, FI, FR, GB, GR, HU, IE, IT, LU, MC, NL, PL, PT, RO, SE, SI, SK, TR), OAPI (BF, BJ, CF, CG, CI, CM, GA, GN, GQ, GW, ML, MR, NE, SN, TD, TG).

**Declarations under Rule 4.17:**

— as to applicant's entitlement to apply for and be granted a patent (Rule 4.17(ii)) for the following designations AE, AG, AL, AM, AT, AU, AZ, BA, BB, BG, BR, BW, BY, BZ, CA, CH, CN, CO, CR, CU, CZ, DE, DK, DM, DZ, EC, EE,

[Continued on next page]

(54) Title: METHOD OF MAKING A COATED ABRASIVE



(57) Abstract: An abrasive article includes an array of protruding abrasive units. Each unit has a base and a distal apex that is off-center from the base when projected on to a plane that is coplanar with the base. The abrasive article includes a backing bonded to an abrasive coating formed to include the aforementioned abrasive units. Methods for making the abrasive article include nipping a production tool, an abrasive slurry, and the backing. A binder within the slurry is cured during fabrication. The abrasive article may be used to abrade a workpiece.

WO 2005/035197 A1



EG, ES, FI, GB, GD, GE, GH, GM, HR, HU, ID, IL, IN, IS, JP, KE, KG, KP, KR, KZ, LC, LK, LR, LS, LT, LU, LV, MA, MD, MG, MK, MN, MW, MX, MZ, NA, NI, NO, NZ, OM, PG, PH, PL, PT, RO, RU, SC, SD, SE, SG, SK, SL, SY, TJ, TM, TN, TR, TT, TZ, UA, UG, UZ, VC, VN, YU, ZA, ZM, ZW, ARIPO patent (BW, GH, GM, KE, LS, MW, MZ, NA, SD, SL, SZ, TZ, UG, ZM, ZW), Eurasian patent (AM, AZ, BY, KG, KZ, MD, RU, TJ, TM), European patent (AT, BE, BG, CH, CY, CZ, DE, DK, EE, ES, FI, FR, GB, GR, HU, IE,

IT, LU, MC, NL, PL, PT, RO, SE, SI, SK, TR), OAPI patent (BF, BJ, CF, CG, CI, CM, GA, GN, GQ, GW, ML, MR, NE, SN, TD, TG)

- as to the applicant's entitlement to claim the priority of the earlier application (Rule 4.17(iii)) for all designations

**Published:**

- with international search report

For two-letter codes and other abbreviations, refer to the "Guidance Notes on Codes and Abbreviations" appearing at the beginning of each regular issue of the PCT Gazette.

## **METHOD OF MAKING A COATED ABRASIVE**

### **Field of the Invention**

This invention pertains to an abrasive array, an abrasive article, a method of making such an abrasive article and a method of using such an abrasive article. The abrasive article comprises a backing having an abrasive coating bonded to at least one surface of the backing. The abrasive coating is shaped to include protruding units exhibiting useful geometries.

### **Background**

Abrasive articles have been utilized to abrade and finish workpieces surfaces for well over a hundred years. These applications have ranged from high stock removal, high pressure metal grinding processes to fine polishing of ophthalmic lenses. In general abrasive articles comprise a plurality of abrasive particles bonded either together (e.g., a bonded abrasive or grinding wheel) or to a backing (e.g., a coated abrasive). For a coated abrasive there is typically a single, or sometimes two layers of abrasive particles. Once these abrasive particles are worn, the coated abrasive is essentially worn out and is typically discarded.

A structured abrasive is taught by U.S. Pat. No. 5,152,917 (Pieper et al.). Importantly, the structured abrasive taught by Pieper results in a relatively high rate of cut and a relatively fine surface finish on the workpiece surface. The structured abrasive comprises non-random, precisely shaped abrasive composites that are bonded to a backing.

Although structured abrasives, such as the one taught by Pieper exhibit desirable characteristics, such as a high cut rate, structured abrasives still tend to lose their effectiveness over time. Thus, a structured abrasive may yield a particular cut rate (expressed, for example, in grams per cycle) in its initial three or four cycles of abrasion, but may yield a cut rate of only a fraction of its initial value after 5 or 10 cycles. Such deterioration in cut rate is inimical to the goal of providing efficient abrasion technology.

As is evident from the foregoing, there exists a need for a scheme by which a structured abrasive may be made to prolong its life span and minimize its cut rate deterioration.

5

### Summary

This invention pertains to an abrasive array, an abrasive article, a method of making an abrasive article and a method of using an abrasive article. According to one embodiment of the present invention, a method of making a coated abrasive article may include introducing a slurry containing a mixture of a binder and a plurality of abrasive grains onto a production tool. The production tool is shaped to include a plurality of protruding units distributed in two dimensions. Each protruding unit has a base that has a periphery. For each unit, its respective distal region, when projected on to a plane that is coplanar with its respective base, defines an offset vector between the projection of the distal region and a center point of the base. The offset vectors for the plurality of protruding units do not exhibit a sum that approaches a limit of zero. The method may further include introducing a backing to the outer surface of the production tool such that the slurry wets one side of the backing to form an intermediate article. The method may further include at least partially curing or gelling the binder before the intermediate article departs from the outer surface of the production tool to form a coated abrasive article. Finally, the method may include removing the coated abrasive article from the production tool.

According to another embodiment, a method of abrading a surface of a workpiece may include providing a coated abrasive article comprising a backing having attached to at least one major surface thereof a plurality of abrasive composites. The abrasive composites include a plurality of protruding units distributed in two dimensions. Each protruding unit has a base that has a periphery. For each unit, its respective distal region, when projected on to a plane that is coplanar with its respective base, defines an offset vector between the projection of the distal region and a center point of the base. The offset vectors for the plurality of protruding units do not exhibit a sum that approaches a limit of zero. The method further includes placing the surface of said article having abrasive composites attached thereto in contact with the surface of said workpiece. Finally, the

method further includes moving at least one of the surfaces of said article or the surface of said workpiece with respect to the other so as to abrade the surface of said workpiece.

According to another embodiment, a method of making a coated abrasive article may include introducing a slurry containing a mixture of a binder and a plurality of  
5 abrasive grains onto a surface of a backing. The method may further include introducing a production tool to the surface of the backing on which the slurry has been introduced to form an intermediate article. The production tool is shaped to include a plurality of protruding units distributed in two dimensions. Each protruding unit has a base that has a periphery. For each unit, its respective distal region, when projected on to a plane that is  
10 coplanar with its respective base, defines an offset vector between the projection of the distal region and a center point of the base. The offset vectors for the plurality of protruding units do not exhibit a sum that approaches a limit of zero. The method further includes at least partially curing or gelling the binder before the intermediate article departs from the production tool to form a coated abrasive article. Finally, the method  
15 further includes removing the coated abrasive article from the production tool.

According to another embodiment, a method of making a coated abrasive article may include introducing a slurry containing a mixture of a binder and a plurality of abrasive grains onto a production tool. The production tool is shaped to include a plurality of protruding units distributed in two dimensions. Each protruding unit has a base that has  
20 a periphery. For each unit, its respective distal region, when projected on to a plane that is coplanar with its respective base, defines an offset vector between the projection of the distal region and a center point of the base. The offset vectors for the plurality of protruding units do not exhibit a sum that approaches a limit of zero. The method may further include introducing a backing to the outer surface of the production tool such that  
25 the slurry wets one side of the backing to form an intermediate article. The method may further include removing the intermediate article from the production tool. Finally, the method may further include curing or gelling the binder to form a coated abrasive article.

According to yet another embodiment, a method of making a coated abrasive may include introducing a slurry containing a mixture of a binder and a plurality of abrasive  
30 grains onto a surface of a backing. The method may further include introducing a production tool to the surface of the backing on which the slurry has been introduced to

form an intermediate article. The production tool is shaped to include a plurality of protruding units distributed in two dimensions. Each protruding unit has a base that has a periphery. For each unit, its respective distal region, when projected on to a plane that is coplanar with its respective base, defines an offset vector between the projection of the distal region and a center point of the base. The offset vectors for the plurality of protruding units do not exhibit a sum that approaches a limit of zero. The method may further include removing the intermediate article from the production tool. Finally, the method may include curing or gelling the binder to form a coated abrasive article.

### Brief Description of the Drawings

**FIG. 1** is a section view, enlarged, representing another abrasive article embodiment of this invention;

**FIG. 2** is a schematic of a process of making the abrasive article of **FIG. 1**; and

**FIG. 3** is a schematic of another process of making the abrasive article of **FIG. 1**.

**FIG. 4A** depicts a top view of a protruding unit in accordance with an embodiment of the present invention.

**FIG. 4B** depicts a top view of a protruding unit in accordance with an embodiment of the present invention.

**FIG. 4C** depicts a top view of an abrasive article in accordance with an embodiment of the present invention.

**FIG. 4D** depicts another top view of an abrasive article in accordance with an embodiment of the present invention.

**FIG. 4E** depicts another top view of a protruding unit in accordance with an embodiment of the present invention.

**FIG. 4F** depicts another top view of a protruding unit in accordance with an embodiment of the present invention.

**FIG. 4G** depicts another top view of a protruding unit in accordance with an embodiment of the present invention.

**FIG. 4H** depicts another top view of a protruding unit in accordance with an embodiment of the present invention.

**FIG. 5** depicts another abrasive article in accordance with an embodiment of the present invention.

**FIG. 6A** depicts an array of protruding units in accordance with an embodiment of the present invention.

5 **FIG. 6B** depicts another array of protruding units in accordance with an embodiment of the present invention.

### Detailed Description

10 This invention pertains to an abrasive array, an abrasive article, a method of making an abrasive article and a method of using an abrasive article.

Referring to **FIG. 1**, the abrasive article **20** comprises abrasive composites **22** separated by boundary **25**. The abrasive composites are bonded to a surface of a backing **21**. The boundary or boundaries associated with the composite shape result in one abrasive composite being separated to some degree from another adjacent abrasive composite. To form an individual abrasive composite, a portion of the boundaries forming the shape of the abrasive composite must be separated from one another. Note that in **FIG. 2**, the base or a portion of the abrasive composite closest to the backing can abut with its neighboring abrasive composite. Abrasive composites **22** comprise a plurality of abrasive particles **24** that are dispersed in a binder **23** and a grinding aid **26**. It is also within the scope of this invention to have a combination of abrasive composites bonded to a backing in which some of the abrasive composites abut, while other abrasive composites have open spaces between them.

### BACKING

25 The backing of this invention has a front and back surface and can be any conventional abrasive backing. Examples of useful backings include polymeric film, primed polymeric film, cloth, paper, vulcanized fiber, nonwovens, and combinations thereof. Other useful backings include a fibrous reinforced thermoplastic backing as disclosed in U.S. Pat. No. 5,316,812 and an endless seamless backing as disclosed in  
30 World Patent Application No. WO 93/12911 published. The backing may also contain a

treatment or treatments to seal the backing and/or modify some physical properties of the backing. These treatments are well known in the art.

The backing may also have an attachment means on its back surface to enable securing the resulting coated abrasive to a support pad or back-up pad. This attachment  
5 means can be a pressure sensitive adhesive, one surface of a hook and loop attachment system, or a threaded projection as disclosed in the above-mentioned U.S. Pat. No. 5,316,812. Alternatively, there may be an intermeshing attachment system as described in the assignee's U.S. Pat. No. 5,201,101 incorporated herein after by reference.

The back side of the abrasive article may also contain a slip resistant or frictional  
10 coating. Examples of such coatings include an inorganic particulate (e.g., calcium carbonate or quartz) dispersed in an adhesive.

## ABRASIVE COATING

### Abrasive Particles

The abrasive particles typically have a particle size ranging from about 0.1 to 1500  
15 micrometers, usually between about 0.1 to 400 micrometers, preferably between 0.1 to 100 micrometers and most preferably between 0.1 to 50 micrometers. It is preferred that the abrasive particles have a Mohs' hardness of at least about 8, more preferably above 9. Examples of such abrasive particles include fused aluminum oxide (which includes brown  
20 aluminum oxide, heat treated aluminum oxide and white aluminum oxide), ceramic aluminum oxide, green silicon carbide, silicon carbide, chromia, alumina zirconia, diamond, iron oxide, ceria, cubic boron nitride, boron carbide, garnet and combinations thereof.

The term "abrasive particle" also encompasses when single abrasive particles are  
25 bonded together to form an abrasive agglomerate. Abrasive agglomerates are further described in U.S. Pat. Nos. 4,311,489; 4,652,275 and 4,799,939 incorporated herein by reference.

It is also within the scope of this invention to have a surface coating on the abrasive  
30 particles. The surface coating may have many different functions. In some instances the surface coatings increase adhesion of abrasive particles to the binder, alter the abrading characteristics of the abrasive particle, and the like. Examples of surface coatings include



coupling agents, halide salts, metal oxides including silica, refractory metal nitrides, refractory metal carbides and the like.

In the abrasive composite there may also be diluent particles. The particle size of these diluent particles may be on the same order of magnitude as the abrasive particles.

5 Examples of such diluent particles include gypsum, marble, limestone, flint, silica, glass bubbles, glass beads, aluminum silicate, and the like.

### Binder

10 The abrasive particles are dispersed in an organic binder to form the abrasive composite. The binder is derived from a binder precursor which comprises an organic polymerizable resin. During the manufacture of the inventive abrasive articles, the binder precursor is exposed to an energy source which aids in the initiation of the polymerization or curing process. Examples of energy sources include thermal energy and radiation energy, the latter including electron beam, ultraviolet light, and visible light. During this  
15 polymerization process, the resin is polymerized and the binder precursor is converted into a solidified binder. Upon solidification of the binder precursor, the abrasive coating is formed. The binder in the abrasive coating is also generally responsible for adhering the abrasive coating to the backing.

20 There are two preferred classes of resins for use in the present invention, condensation curable and addition polymerizable resins. The preferred binder precursors comprise additional polymerizable resins because these resins are readily cured by exposure to radiation energy. Addition polymerizable resins can polymerize through a cationic mechanism or a free radical mechanism. Depending upon the energy source that is utilized and the binder precursor chemistry, a curing agent, initiator, or catalyst is  
25 sometimes preferred to help initiate the polymerization.

30 Examples of typical and preferred organic resins include phenolic resins, urea-formaldehyde resins, melamine formaldehyde resins, acrylated urethanes, acrylated epoxies, ethylenically unsaturated compounds, aminoplast derivatives having pendant unsaturated carbonyl groups, isocyanurate derivatives having at least one pendant acrylate group, isocyanate derivatives having at least one pendant acrylate group, vinyl ethers,

epoxy resins, and mixtures and combinations thereof. The term "acrylate" encompasses acrylates and methacrylates.

Phenolic resins are widely used in abrasive article binders because of their thermal properties, availability, and cost. There are two types of phenolic resins, resole and novolac. Resole phenolic resins have a molar ratio of formaldehyde to phenol of greater than or equal to one to one, typically between 1.5:1.0 to 3.0:1.0. Novolac resins have a molar ratio of formaldehyde to phenol of less than one to one. Examples of commercially available phenolic resins include those known by the tradenames "Durez" and "Varcum" from Occidental Chemicals Corp.; "Resinox" from Monsanto; "Aerofene" from Ashland Chemical Co. and "Aerotap" from Ashland Chemical Co.

Acrylated urethanes are diacrylate esters of hydroxy-terminated, isocyanate NCO extended polyesters or polyethers. Examples of commercially available acrylated urethanes include those known under the trade designations "UVITHANE 782", available from Morton Thiokol Chemical, and "CMD 6600", "CMD 8400", and "CMD 8805", available from Radcure Specialties.

Acrylated epoxies are diacrylate esters of epoxy resins, such as the diacrylate esters of bisphenol A epoxy resin. Examples of commercially available acrylated epoxies include those known under the trade designations "CMD 3500", "CMD 3600", and "CMD 3700", available from Radcure Specialties.

Ethylenically unsaturated resins include both monomeric and polymeric compounds that contain atoms of carbon, hydrogen, and oxygen, and optionally, nitrogen and the halogens. Oxygen or nitrogen atoms or both are generally present in ether, ester, urethane, amide, and urea groups.

Ethylenically unsaturated compounds preferably have a molecular weight of less than about 4,000 and are preferably esters made from the reaction of compounds containing aliphatic monohydroxy groups or aliphatic polyhydroxy groups and unsaturated carboxylic acids, such as acrylic acid, methacrylic acid, itaconic acid, crotonic acid, isocrotonic acid, maleic acid, and the like. Representative examples of acrylate resins include methyl methacrylate, ethyl methacrylate styrene, divinylbenzene, vinyl toluene, ethylene glycol diacrylate, ethylene glycol methacrylate, hexanediol diacrylate, triethylene glycol diacrylate, trimethylolpropane triacrylate, glycerol triacrylate, pentaerythritol

triacrylate, pentaerythritol methacrylate, pentaerythritol tetraacrylate and pentaerythritol tetraacrylate. Other ethylenically unsaturated resins include monoallyl, polyallyl, and polymethallyl esters and amides of carboxylic acids, such as diallyl phthalate, diallyl adipate, and N,N-diallyladkipamide. Still other nitrogen containing compounds include  
5 tris(2-acryloyloxyethyl)isocyanurate, 1,3,5-tri(2-methacryloxyethyl)-triazine, acrylamide, methylacrylamide, N-methylacrylamide, N,N-dimethylacrylamide, N-vinylpyrrolidone, and N-vinylpiperidone.

The aminoplast resins have at least one pendant alpha, betaunsaturated carbonyl group per molecule or oligomer. These unsaturated carbonyl groups can be acrylate,  
10 methacrylate, or acrylamide type groups. Examples of such materials include N-(hydroxymethyl)acrylamide, N,N'-oxydimethylenebisacrylamide, ortho and para acrylamidomethylated phenol, acrylamidomethylated phenolic novolac, and combinations thereof. These materials are further described in U.S. Pat. Nos. 4,903,440 and 5,236,472 both incorporated herein by reference.

15 Isocyanurate derivatives having at least one pendant acrylate group and isocyanate derivatives having at least one pendant acrylate group are further described in U.S. Pat. No. 4,652,274 incorporated herein after by reference. The preferred isocyanurate material is a triacrylate of tris(hydroxy ethyl) isocyanurate.

Epoxy resins have an oxirane and are polymerized by the ring opening. Such  
20 epoxide resins include monomeric epoxy resins and oligomeric epoxy resins. Examples of some preferred epoxy resins include 2,2-bis[4-(2,3-epoxypropoxy)-phenyl propane] (diglycidyl ether of bisphenol) and commercially available materials under the trade designations "Epon 828", "Epon 1004", and "Epon 1001F" available from Shell Chemical Co., "DER-331", "DER-332", and "DER-334" available from Dow Chemical Co. Other  
25 suitable epoxy resins include glycidyl ethers of phenol formaldehyde novolac (e.g., "DEN-431" and "DEN-428" available from Dow chemical Co.).

The epoxy resins of the invention can polymerize via a cationic mechanism with the addition of an appropriate cationic curing agent. Cationic curing agents generate an acid source to initiate the polymerization of an epoxy resin. These cationic curing agents  
30 can include a salt having an onium cation and a halogen containing a complex anion of a metal or metalloid. Other cationic curing agents include a salt having an organometallic

complex cation and a halogen containing complex anion of a metal or metalloid which are further described in U.S. Pat. No. 4,751,138 incorporated here in after by reference (column 6, line 65 to column 9, line 45). Another example is an organometallic salt and an onium salt is described in U.S. Pat. No. 4,985,340 (column 4, line 65 to column 14, line 50); and European Patent Application Nos. 306,161 and 306,162, both published Mar. 8, 1989, all incorporated by reference. Still other cationic curing agents include an ionic salt of an organometallic complex in which the metal is selected from the elements of Periodic Group IVB, VB, VIB, VIIB and VIIIB which is described in European Patent Application No. 109,581, published Nov. 21, 1983, incorporated by reference.

Regarding free radical curable resins, in some instances it is preferred that the abrasive slurry further comprise a free radical curing agent. However in the case of an electron beam energy source, the curing agent is not always required because the electron beam itself generates free radicals.

Examples of free radical thermal initiators include peroxides, e.g., benzoyl peroxide, azo compounds, benzophenones, and quinones. For either ultraviolet or visible light energy source, this curing agent is sometimes referred to as a photoinitiator. Examples of initiators, that when exposed to ultraviolet light generate a free radical source, include but are not limited to those selected from the group consisting of organic peroxides, azo compounds, quinones, benzophenones, nitroso compounds, acryl halides, hydrozones, mercapto compounds, pyrylium compounds, triacrylimdazoles, bisimidazoles, chloroalkyltriazines, benzoin ethers, benzil ketals, thioxanthenes, and acetophenone derivatives, and mixtures thereof. Examples of initiators that when exposed to visible radiation generate a free radical source, can be found in U.S. Pat. No. 4,735,632, entitled Coated Abrasive Binder Containing Ternary Photoinitiator System, incorporated herein by reference. The preferred initiator for use with visible light is "Irgacure 369" commercially available from Ciba Geigy Corporation.

#### GRINDING AID

A grinding aid is defined as a material, preferably a particulate material, the addition of which to an abrasive article has a significant effect on the chemical and physical processes of abrading which results in improved performance. Typically and

preferably the grinding aid is added to the slurry as a particulate, however it may be added to the slurry as a liquid. The presence of the grinding aid will increase the grinding efficiency or cut rate (defined as weight of work piece removed per weight of abrasive article lost) of the corresponding abrasive article in comparison to an abrasive article that does not contain a grinding aid. In particular, it is believed in the art that the grinding aid will either 1) decrease the friction between the abrasive grains and the workpiece being abraded, 2) prevent the abrasive grain from "capping", i.e., prevent metal particles (in the case of a metal workpiece) from becoming welded to the tops of the abrasive grains, 3) decrease the interface temperature between the abrasive grains the workpiece, 4) decreases the grinding force required, or 5) prevents oxidation of the metal workpiece. In general, the addition of a grinding aid increases the useful life of the abrasive article.

Grinding aids useful in the invention encompass a wide variety of different materials and can be inorganic or organic based. Examples of chemical groups of grinding aids include waxes, organic halide compounds, halide salts and metals and their alloys. The organic halide compounds will typically break down during abrading and release a halogen acid or a gaseous halide compound. Examples of such materials include chlorinated waxes like tetrachloronaphthalene, pentachloronaphthalene; and polyvinyl chloride. Examples of halide salts include sodium chloride, potassium cryolite, sodium cryolite, ammonium cryolite, potassium tetrafluoroborate, sodium tetrafluoroborate, silicon fluorides, potassium chloride, magnesium chloride. Examples of metals include, tin, lead, bismuth, cobalt, antimony, cadmium, iron titanium, other miscellaneous grinding aids include sulfur, organic sulfur compounds, graphite and metallic sulfides. It is also within the scope of this invention to use a combination of different grinding aids and in some instances this may produce a synergistic effect.

The above-mentioned examples of grinding aids are meant to be representative only. A preferred grinding aid for use in the invention is cryolite, and the most preferred is potassium tetrafluoroborate (KBF.sub.4).

The grinding aid is considered to be non-abrasive, that is, the Moh hardness of the grinding aid is less than 8. The grinding aid may also contain impurities; these impurities should not significantly adversely affect performance of the abrasive article.

The grinding aid particle size preferably ranges from about 0.1 to 100 micrometers, more preferably between 10 to 70 micrometers. In general the particle size of the grinding aid is preferably equal to or less than the size of the abrasive particles.

5 The abrasive coating comprises generally at least about 1% by weight, typically at least about 2.5% by weight, preferably at least about 5% by weight, more preferably at least about 10% by weight grinding aid and most preferably at least about 20% by weight grinding aid. More than about 50 weight % grinding aid may be detrimental since it is theorized that grinding performance would decrease (since there are less abrasive particles present). It was surprising that as the amount of grinding aid was increased, the relative  
10 grinding performance as measured by cut rate is also increased. This was unexpected since as the amount of grinding aid in the abrasive coating is increased, the relative amount of abrasive particles is decreased. The abrasive particles are responsible for cutting the workpiece surface, not the grinding aid. In general, the abrasive coating comprises from 5 to 90% by weight, preferably from 20 to 80% by weight abrasive particles, from 5 to 80%  
15 by weight, preferably from 5 to 40% by weight binder, and from 5 to 60% by weight, preferably from 10 to 40% by weight grinding aid.

#### OPTIONAL ADDITIVES

Slurries useful in the invention may further comprise optional additives, such as,  
20 for example, fillers, fibers, lubricants, wetting agents, thixotropic materials, surfactants, pigments, dyes, antistatic agents, coupling agents, plasticizers, and suspending agents. The amounts of these materials are selected to provide the properties desired. The use of these can affect the erodability of the abrasive composite. In some instances an additive is purposely added to make the abrasive composite more erodable, thereby expelling dulled  
25 abrasive particles and exposing new abrasive particles.

Examples of antistatic agents useful in the invention include graphite, carbon black, vanadium oxide, humectants, and the like. These antistatic agents are disclosed in U.S. Pat. Nos. 5,061,294; 5,137,542, and 5,203,884 incorporated herein after by reference.

30 A coupling agent can provide an association bridge between the binder precursor and the filler particles or abrasive particles. Examples of useful coupling agents include

silanes, titanates, and zircoaluminates. Useful slurries preferably contain from about 0.01 to 3% by weight coupling agent.

An example of a suspending agent useful in the invention is an amorphous silica particle having a surface area less than 150 meters square/gram that is commercially  
5 available from DeGussa Corp., under the trade name "OX-50".

#### ABRASIVE COATING COMPRISING ABRASIVE COMPOSITES

In one preferred aspect of the invention, the abrasive coating is in the form of a plurality of abrasive composites bonded to the backing. It is generally preferred that each  
10 abrasive composites have a precise shape. The precise shape of each composite is determined by distinct and discernible boundaries. These distinct and discernible boundaries are readily visible and clear when a cross section of the abrasive article is examined under a microscope such as a scanning electron microscope. In comparison, in an abrasive coating comprising composites that do not have precise shapes, the boundaries  
15 are not definitive and may be illegible. These distinct and discernible boundaries form the outline or contour of the precise shape. These boundaries separate to some degree one abrasive composite from another and also distinguish one abrasive composite from another.

Referring to **FIG. 1**, the abrasive article **10** comprises abrasive composites **22**  
20 separated by boundary **25**. The boundary or boundaries associated with the composite shape result in one abrasive composite being separated to some degree from another adjacent abrasive composite. To form an individual abrasive composite, a portion of the boundaries forming the shape of the abrasive composite must be separated from one another. Note that in **FIG. 1**, the base or a portion of the abrasive composite closest to the  
25 backing can abut with its neighboring abrasive composite. Abrasive composites **22** comprise a plurality of abrasive particles **24** that are dispersed in a binder **23** and a grinding aid **26**. It is also within the scope of this invention to have a combination of abrasive composites bonded to a backing in which some of the abrasive composites abut, while other abrasive composites have open spaces between them.

30 In some instances the boundaries forming the shape are planar. For shapes that have planes, there are at least three planes. The number of planes for a given shape can

vary depending upon the desired geometry, for instance the number of planes can range from three to over 20. Generally, there are between three to ten planes, preferably between three to six planes. These planes intersect to form the desired shape and the angles at which these planes intersect will determine the shape dimensions.

5 In another aspect of this invention, a portion of the abrasive composites have a neighboring abrasive composite of a different dimension. In this aspect of the invention, at least 10%, preferably at least 30%, more preferably at least 50% and most preferably at least 60% of the abrasive composites have an adjacent abrasive composite that has a different dimension. These different dimensions can pertain to the abrasive composite  
10 shape, angle between planar boundaries or dimensions of the abrasive composite. The result of these different dimensions for neighboring abrasive composites results in an abrasive article that produces a relatively finer surface finish on the workpiece being abraded or refined. This aspect of the invention is further described in the assignee's co-  
pending patent application U.S. Ser. No. 08/120,300 filed Sep. 13, 1993.

15 The abrasive composite shape can be any shape, but it is preferably a geometric shape such as a rectangle, cone, semicircle, circle, triangle, square, hexagon, pyramid, octagon and the like. Embodiments of preferred shapes are presented below in a section entitled "GEOMETRIES." An individual abrasive composite shape may be referred to herein as a "protruding unit." One other shape is a pyramid and the base of this pyramid  
20 can be a three or four sided. It is also preferred that the abrasive composite cross sectional surface area decreases away from the backing or decreases along its height. This variable surface area results in a non-uniform pressure as the abrasive composite wears during use. Additionally, during manufacture of the abrasive article, this variable surface area results in easier release of the abrasive composite from the production tool. In general there are at  
25 least 5 individual abrasive composites per square cm. In some instances, there may be at least 500 individual abrasive composites/square cm.

#### METHOD OF MAKING THE ABRASIVE ARTICLE

30 An essential step to make any of the inventive abrasive articles is to prepare the slurry. The slurry is made by combining together by any suitable mixing technique the binder precursor, the grinding aid, the abrasive particles and the optional additives.



Examples of mixing techniques include low shear and high shear mixing, with high shear mixing being preferred. Ultrasonic energy may also be utilized in combination with the mixing step to lower the abrasive slurry viscosity. Typically, the abrasive particles and grinding aid are gradually added into the binder precursor. The amount of air bubbles in the slurry can be minimized by pulling a vacuum during the mixing step. In some instances it is preferred to heat, generally in the range of 30° to 70° C., the slurry to lower the viscosity. It is important the slurry have rheological properties that allow the slurry to coat well and in which the abrasive particles and grinding aid do not settle out of the slurry.

#### ENERGY SOURCE

After the slurry is coated onto the backing, such as via transfer from a production tool (discussed below), the slurry may be exposed to an energy source to initiate the polymerization of the resin in the binder precursor. Examples of energy sources include thermal energy and radiation energy. The amount of energy depends upon several factors such as the binder precursor chemistry, the dimensions of the abrasive slurry, the amount and type of abrasive particles and the amount and type of the optional additives. For thermal energy, the temperature can range from about 30° to 150° C., generally from 40° to 120° C. The exposure time can range from about 5 minutes to over 24 hours.

Suitable radiation energy sources include electron beam, ultraviolet light, or visible light. Electron beam radiation, which is also known as ionizing radiation, can be used at an energy level of about 0.1 to about 10 Mrad, preferably at an energy level of about 1 to about 10 Mrad. Ultraviolet radiation refers to non-particulate radiation having a wavelength within the range of about 200 to about 400 nanometers, preferably within the range of about 250 to 400 nanometers. Visible radiation refers to non-particulate radiation having a wavelength within the range of about 400 to about 800 nanometers, preferably in the range of about 400 to about 550 nanometers. It is preferred that 300 to 600 Watt/inch visible lights are used.

After this polymerization process is complete, the binder precursor is converted into a binder and the slurry is converted into an abrasive coating. The resulting abrasive article is generally ready for use. However, in some instances other processes may still be

necessary such as humidification or flexing. The abrasive article can be converted into any desired form such as a cone, endless belt, sheet, disc, and the like, before the abrasive article is used.

5 PRODUCTION TOOL

Regarding the third and fourth aspects of the invention, in some instances it is preferred that the abrasive coating be present as precisely shaped abrasive composites. In order to make this type of abrasive article, a production tool is generally required.

10 The production tool contains a plurality of cavities. These cavities are essentially the inverse shape of the abrasive composite and are responsible for generating the shape of the abrasive composites. The dimensions of the cavities are selected to provide the desired shape and dimensions of the abrasive composites. If the shape or dimensions of the cavities are not properly fabricated, the resulting production tool will not provide the desired dimensions for the abrasive composites.

15 The cavities can be present in a dot like pattern with spaces between adjacent cavities or the cavities can butt up against one another. It is preferred that the cavities butt up against one another. Additionally, the shape of the cavities is selected such that the cross-sectional area of the abrasive composite decreases away from the backing.

20 The production tool can be a belt, a sheet, a continuous sheet or web, a coating roll such as a rotogravure roll, a sleeve mounted on a coating roll, or die. The production tool can be composed of metal, (e.g., nickel), metal alloys, or plastic. The metal production tool can be fabricated by any conventional technique such as engraving, bobbing, electroforming, diamond turning, and the like. One preferred technique for a metal production tool is diamond turning.

25 A thermoplastic tool can be replicated off a metal master tool. The master tool will have the inverse pattern desired for the production tool. The master tool can be made in the same manner as the production tool. The master tool is preferably made out of metal, e.g., nickel and is diamond turned. The thermoplastic sheet material can be heated and optionally along with the master tool such that the thermoplastic material is embossed with  
30 the master tool pattern by pressing the two together. The thermoplastic can also be extruded or cast onto the master tool and then pressed. The thermoplastic material is

cooled to solidify and produce the production tool. Examples of preferred thermoplastic production tool materials include polyester, polycarbonates, polyvinyl chloride, polypropylene, polyethylene and combinations thereof. If a thermoplastic production tool is utilized, then care must be taken not to generate excessive heat that may distort the thermoplastic production tool.

The production tool may also contain a release coating to permit easier release of the abrasive article from the production tool. Examples of such release coatings for metals include hard carbide, nitrides or borides coatings. Examples of release coatings for thermoplastics include silicones and fluorochemicals.

One method to make the abrasive article of the invention illustrated in **FIG. 2** is illustrated in **FIG. 2**. Backing **41** leaves an unwind station **42** and at the same time the production tool **46** leaves an unwind station **45**. Production tool **46** is coated with slurry by means of coating station **44**. It is possible to heat the slurry and/or subject the slurry to ultrasonics prior to coating to lower the viscosity. The coating station can be any conventional coating means such as drop die coater, knife coater, curtain coater, vacuum die coater or a die coater. During coating the formation of air bubbles should be minimized. The preferred coating technique is a vacuum fluid bearing die, such as disclosed in U.S. Pat. Nos. 3,594,865, 4,959,265, and 5,077,870, all incorporated herein by reference. After the production tool is coated, the backing and the slurry are brought into contact by any means such that the slurry wets the front surface of the backing. In **FIG. 2**, the slurry is brought into contact with the backing by means of contact nip roll **47**. Next, contact nip roll **47** also forces the resulting construction against support drum **43**. A source of energy **48** (preferably a source of visible light) transmits a sufficient amount of energy into the slurry to at least partially cure the binder precursor. The term partial cure is meant that the binder precursor is polymerized to such a state that the slurry does not flow from an inverted test tube. The binder precursor can be fully cured once it is removed from the production tool by any energy source. Following this, the production tool is rewound on mandrel **49** so that the production tool can be reused again. Optionally, the production tool may be removed from the binder precursor prior to any curing of the precursor at all. After removal, the precursor may be cured, and the production tool may be rewound on mandrel **49** for reuse. Additionally, abrasive article **120** is wound on

mandrel **121**. If the binder precursor is not fully cured, the binder precursor can then be fully cured by either time and/or exposure to an energy source. Additional steps to make abrasive articles according to this first method are further described in U.S. Pat. No. 5,152,917 and U.S. Ser. No. 08/004,929, filed Jan. 14, 1993, both incorporated herein by reference. Randomly shaped abrasives composites may be made by the tooling and procedures described in copending Ser. No. 08/120,300, filed Sep. 13, 1993, incorporated herein by reference.

It is preferred that the binder precursor is cured by radiation energy. The radiation energy can be transmitted through the production tool so long as the production tool does not appreciably absorb the radiation energy. Additionally, the radiation energy source should not appreciably degrade the production tool. It is preferred to use a thermoplastic production tool and ultraviolet or visible light.

The slurry can be coated onto the backing and not into the cavities of the production tool. The slurry coated backing is then brought into contact with the production tool such that the slurry flows into the cavities of the production tool. The remaining steps to make the abrasive article are the same as detailed above.

Another method is illustrated in **FIG. 3**. Backing **51** leaves an unwind station **52** and the slurry **54** is coated into the cavities of the production tool **55** by means of the coating station **53**. The slurry can be coated onto the tool by any one of many techniques such as drop die coating, roll coating, knife coating, curtain coating, vacuum die coating, or die coating. Again, it is possible to heat the slurry and/or subject the slurry to ultrasonics prior to coating to lower the viscosity. During coating the formation of air bubbles should be minimized. Then, the backing and the production tool containing the abrasive slurry are brought into contact by a nip roll **56** such that the slurry wets the front surface of the backing. Next, the binder precursor in the slurry is at least partially cured by exposure to an energy source **57**. After this at least partial cure, the slurry is converted to an abrasive composite **59** that is bonded or adhered to the backing. The resulting abrasive article is removed from the production tool by means of nip rolls **58** and wound onto a rewind station **60**. Optionally, the production tool may be removed from the binder precursor prior to any curing of the precursor at all. After removal of the production tool, the precursor may be cured. In either event, the energy source can be thermal energy or

radiation energy. If the energy source is either ultraviolet light or visible light, it is preferred that the backing be transparent to ultraviolet or visible light. An example of such a backing is polyester backing.

5 The slurry can be coated directly onto the front surface of the backing. The slurry coated backing is then brought into contact with the production tool such that the slurry wets into the cavities of the production tool. The remaining steps to make the abrasive article are the same as detailed above.

#### METHOD OF REFINING A WORKPIECE SURFACE

10 Another aspect of this invention pertains to a method of abrading a metal surface. This method involves bringing into frictional contact the abrasive article of this invention with a workpiece having a metal surface. The term "abrading" means that a portion of the metal workpiece is cut or removed by the abrasive article. Additionally, the surface finish associated with the workpiece surface is typically reduced after this refining process. One  
15 typical surface finish measurement is Ra; Ra is the arithmetic surface finish generally measured in microinches or micrometers. The surface finish can be measured by a profilometer, such as a Perthometer or Surtronic.

#### WORKPIECE

20 The metal workpiece can be any type of metal such as mild steel, stainless steel, titanium, metal alloys, exotic metal alloys and the like. The workpiece may be flat or may have a shape or contour associated with it.

Depending upon the application, the force at the abrading interface can range from about 0.1 kg to over 1000 kg. Generally this range is from 1 kg to 500 kg of force at the  
25 abrading interface. Also depending upon the application, there may be a liquid present during abrading. This liquid can be water and/or an organic compound. Examples of typical organic compounds include lubricants, oils, emulsified organic compounds, cutting fluids, soaps, or the like. These liquids may also contain other additives such as defoamers, degreasers, corrosion inhibitors, or the like. The abrasive article may oscillate  
30 at the abrading interface during use. In some instances, this oscillation may result in a finer surface on the workpiece being abraded.

The abrasive articles of the invention can be used by hand or used in combination with a machine. At least one or both of the abrasive article and the workpiece is moved relative to the other during grinding. The abrasive article can be converted into a belt, tape roll, disc, sheet, and the like. For belt applications, the two free ends of an abrasive sheet are joined together and a splice is formed. It is also within the scope of this invention to use a spliceless belt like that described in the assignee's co-pending patent application U.S. Ser. No. 07/919,541, filed Jul. 24, 1992, incorporated herein after by reference. Generally the endless abrasive belt traverses over at least one idler roll and a platen or contact wheel. The hardness of the platen or contact wheel is adjusted to obtain the desired rate of cut and workpiece surface finish. The abrasive belt speed depends upon the desired cut rate and surface finish. The belt dimensions can range from about 5 mm to 1,000 mm wide and from about 5 mm to 10,000 mm long. Abrasive tapes are continuous lengths of the abrasive article. They can range in width from about 1 mm to 1,000 mm, generally between 5 mm to 250 mm. The abrasive tapes are usually unwound, traverse over a support pad that forces the tape against the workpiece and then rewound. The abrasive tapes can be continuously feed through the abrading interface and can be indexed. The abrasive disc can range from about 50 mm to 1,000 mm in diameter. Typically abrasive discs are secured to a back-up pad by an attachment means. These abrasive discs can rotate between 100 to 20,000 revolutions per minute, typically between 1,000 to 15,000 revolutions per minute.

### GEOMETRIES

As alluded to in the section of this disclosure entitled "ABRASIVE COATING COMPRISING ABRASIVE COMPOSITES," the abrasive composites may be shaped into units that protrude from the backing to which they are bonded. The individual shaped composite abrasives are referred to herein as "protruding units." The particular geometry chosen for the protruding units may impact the performance of the structured abrasive article in which they are situated. The geometry schemes presented below are chosen to provide elevated initial cut rates (as measured in mass per cycle) and to exhibit minimal deterioration in cut rates with each successive abrasion cycle.

The protruding units shown in **FIGS. 4A-H, 5, and 6A and 6B**, and the other protruding units discussed herein may be structured from materials described above, making use of fabrication methods described above. Although **FIGS. 4A-H, 5, and 6A and 6B** do not depict abrasive grains and binder within the protruding units, it is understood that such grains and binder exist, as the protruding units have abrasive grains and binder as a constituent material.

**FIG. 4A** depicts a top view of a protruding unit **400**. The protruding unit has a base **401**, which is in the shape of a square. Other than the base **401**, the protruding unit **400** has four sides, which extend from each of the various sides of the base **401** to a linear apex **406**. Due to the perspective of **FIG. 4A**, only sides **403** and **405** are visible.

As can be seen from **FIG. 4A**, the linear apex **406**, when projected on to a plain that is coplanar with the base **401**, extends between oppositely disposed sides of the base **401**. When referring to the projection of an apex, such as apex **406**, on to a plain that is coplanar with a base of a protruding unit, the terms "projection of the apex" or "projection of the linear apex" may be used herein. The center points of the oppositely disposed sides between which the projection of the linear apex **406** extends are identified with small hashings. The projection of the linear apex **406** does not extend between the center points of the oppositely disposed sides.

The protruding unit of **FIG. 4A** may be arranged into a two-dimensional array, as shown in **FIG. 4B**. **FIG. 4B** depicts an array of substantially identical protruding units **400** disposed such that the base of each protruding unit **400** abuts the base of an adjacent protruding unit **400**. The protruding units **400** are shown as being bonded to a backing **408**, creating an abrasive article. Although the array depicted in **FIG. 4B** is shown as being two-by-two, the array may be of any size in principle. Furthermore, as shown in **FIG. 4C**, the array may be constructed so that the bases of adjacent protruding units **400** do not abut one another.

**FIG. 4D** depicts a protruding unit **410**. As can be seen therein, the protruding unit has a linear apex **412** that has a length that is insufficient for its projection to extend from one side of the base **414** to the other. Thus, each of the sides tapers inwardly from the base **414** toward the distal linear apex. Notably, if the projection of the linear apex **412** is extrapolated, its extrapolation does not meet with a center point of either oppositely

disposed side of the base **414**. In this way, it can be said that the projection of the linear apex **412** does not extend "between" center points of oppositely disposed sides of the base **414**.

**FIG. 4E** depicts yet another protruding unit **416**. The protruding units depicted in **FIGS. 4A, 4B, 4C, and 4D** exhibit the characteristic that their respective linear apices **412** do not extend between center points of oppositely disposed sides of their respective bases via employment of a similar scheme: the linear apices have been askew to all of the sides of their respective bases. As shown in **FIG. 4E**, the projection of the linear apex **418** may be parallel to some of the sides of the base **420**, and yet not extend between center points of oppositely disposed sides of the base **420**.

**FIG. 4F** depicts yet another protruding unit **422**. **FIG. 4F** demonstrates that while the apex of a protruding unit may be linear, it is not essential that it be rectilinear. The protruding unit **422** has a curvilinear (as opposed to rectilinear) apex **424**. The projection of the curvilinear apex **424** does not extend between center points of oppositely disposed sides of the base **426**.

The bases that have been presented in **FIGS. 4A, 4B, 4C, 4D, 4E, and 4F** have all been in the shape of a square. Such a restriction is not essential. In principle, the base may be any closed shape. For example, the base may be any regular or irregular polygon, may be a parallelogram, rectangle, or any for of quadrilateral. The base may be circular or elliptical. The sides of the base may be rectilinear or curvilinear. For example, the protruding unit **428** depicted in **FIG. 4G** has four sides, two of which are curvilinear **430** and **432**. The center point of the oppositely disposed curvilinear sides of the base may be found by dividing the curvilinear sides into two segments, wherein the length of the first segment is equal to the length of the second segment. For example, side **430** has been divided into two segments: segments **AB** and **BC**. Point **B**, the center point, is positioned so that the length of segment **AB** is equal to the length of segment **BC**. One skilled in the art understands that other measures of centrality may be used to identify the center point of a line that is not rectilinear. Again, the projection of the linear apex **434** extends between oppositely disposed sides **430** and **432**, but not at their respective center points.

**FIG. 4H** depicts a protruding unit **436** that has a base **438** that is in the shape of a pentagon. The center point of side **AB** is identified with a small hash mark. Notably,



protruding unit **436** does not, at first glance, appear to have a side disposed opposite of side **AB**. For the sake of orienting the linear apex **440** so as to extend between non-central points on oppositely disposed sides of a base, one may consider the side opposite **AB** to be the compound segment **ACDEB**. The center point of side **ACDEB** is point **D**, because the  
5 length of segment **ACD** equals the length of segment **DEB**. Thus, it is plain to see that linear apex **440** does not extend between center point of oppositely disposed sides of the base **438**.

The general principle to be extracted from the discussion associated with **FIG. 4H** is that a particular scheme can be used to find a side that is disposed opposite a given side  
10 of a base. In short, a set of sides that subtends a given side of a base may collectively be considered a single side that is disposed opposite the given side (e.g., side **ACDEB** subtends side **AB**, and may be considered to be disposed opposite side **AB**).

**FIG. 5** depicts a perspective view of an abrasive article **500** including a two dimensional array of protruding units, some of which have been identified with reference  
15 numeral **502**. Each protruding unit **502** has a base that is rectangular. According to one embodiment of the present invention, the length and width of the base may be between 1 and 150 mils. Each base has a linear apex **504**. According to one embodiment of the present invention, the linear apex may be oriented up to 60 mils above the base. Although each of the bases in **FIG. 5** is depicted as having the same size and geometry, neither  
20 condition is essential. The bases may be of varying size and/or geometry. Also, although each of the linear apexes **504** is depicted as being parallel with one another, this condition is not essential. The linear apexes **504** may be non-parallel to one another. Finally, although each of the linear apexes is depicted as being a constant distance from their respective bases, this condition is also not essential. The distance between the bases and  
25 their respective linear apexes **504** may vary from protruding unit **502** to protruding unit **502**.

**FIG. 6A** depicts an array of protruding units **600-606**. Each of the protruding units **600-606** has an apex **608-614** that is substantially in the shape of a point. Any of the linear apexes in any of the preceding examples may be embodied as a point, as opposed to being  
30 embodied as a linear segment. Returning the discussion to **FIG. 6A**, in each of the protruding units **600-606**, the apex **608-614** is located remote from the center. The

projection of each apex **608-614** defines an offset vector  $v_1, v_2, v_3,$  and  $v_4$  extending from the center and/or center of mass of the respective base to the projection of the apex **608-614**. Notably, the sum of the offset vectors  $v_1, v_2, v_3,$  and  $v_4$  does not equal zero. For example, assuming that each of the offset vectors  $v_1, v_2, v_3,$  and  $v_4$  is a unit vector, the sum of the vectors is  $2y$ . For a large array of protruding units, the sum of the offset vectors should not approach a limit of zero as the number of vectors summed together approaches infinity:

$$\lim_{n \rightarrow \infty} (\sum v_n) \neq 0$$

10

Stated another way, when viewed in totality, the array should exhibit net directionality with respect to the positioning of the apexes **608-614**.

**FIG. 6B** shows the idea of net proportionality as it applies to protruding units having linear apexes **616-622**. As can be seen from **FIG. 6B**, the projection of the linear apexes **616-622** define an offset vector  $v_1, v_2, v_3,$  and  $v_4$  extending from the centers and/or centers of mass of the respective base to the center of the projection of the apexes **616-622**. Once again, for a large array of protruding units, the sum of the offset vectors should not approach a limit of zero as the number of vectors summed together approaches infinity:

15

$$\lim_{n \rightarrow \infty} (\sum v_n) \neq 0$$

20 Stated another way, when viewed in totality, the array should exhibit net directionality with respect to the positioning of the apexes **608-614**.

Various modifications and alterations of this invention will become apparent to those skilled in the art without departing from the scope and spirit of this invention, and it should be understood that this invention is not to be unduly limited to the illustrative embodiments set forth herein.

25

What is claimed is:

1. A method of making a coated abrasive article comprising the steps of:
  - (a) introducing a slurry containing a mixture of a binder and a plurality of  
abrasive grains onto a production tool, wherein the production tool is shaped to include  
5 a plurality of protruding units distributed in two dimensions,  
wherein each protruding unit has a base that has a periphery,  
wherein, for each unit, its respective distal region, when projected on to a  
plane that is coplanar with its respective base, falls within the periphery of the base,  
and defines an offset vector between the projection of the distal region and a center  
10 point of the base; and  
wherein the offset vectors for the plurality of protruding units do not exhibit  
a sum that approaches a limit of zero;
  - (b) introducing a backing to the outer surface of the production tool such that  
the slurry wets one side of the backing to form an intermediate article;
  - 15 (c) at least partially curing the binder before the intermediate article departs  
from the outer surface of the production tool to form a coated abrasive article; and
  - (d) removing the coated abrasive article from the production tool.
2. The method of claim 1, wherein each distal region is linear.  
20
3. The method of claim 2, wherein each distal region is rectilinear.
4. The method of claim 2, wherein each distal region is curvilinear.
- 25 5. The method of claim 1, wherein each base is a parallelogram.
6. The method of claim 5, wherein none of the sides of the parallelogram is  
parallel to an edge of an article upon which the abrasive array is disposed.

7. The method of claim 1, wherein for each unit, its respective distal region, when projected on to a plane that is coplanar with its respective base, falls within the periphery of the base.

5 8. The method of claim 1, wherein consecutive bases do not abut.

9. A method of abrading a surface of a workpiece comprising steps of:

10 (a) providing a coated abrasive article comprising a backing having attached to at least one major surface thereof a plurality of abrasive composites, wherein the abrasive composites include a plurality of protruding units distributed in two dimensions,

wherein each protruding unit has a base that has a periphery,

wherein, for each unit, its respective distal region, when projected on to a plane that is coplanar with its respective base, falls within the periphery of the base, and defines an offset vector between the projection of the distal region and a center point of the base; and

15 wherein the offset vectors for the plurality of protruding units do not exhibit a sum that approaches a limit of zero;

(b) placing the surface of said article having abrasive composites attached thereto in contact with the surface of said workpiece; and

20 (c) moving at least one of the surface of said article or the surface of said workpiece with respect to the other so as to abrade the surface of said workpiece.

10. The method of claim 9, wherein each distal region is linear.

25 11. The method of claim 10, wherein each distal linear region is rectilinear.

12. The method of claim 10, wherein each distal linear region is curvilinear.

13. The method of claim 9, wherein each base is a parallelogram.

30

14. The method of claim 13, wherein none of the sides of the parallelogram is parallel to an edge of an article upon which the abrasive array is disposed.

5 15. The method of claim 9, wherein for each unit, its respective distal region, when projected on to a plane that is coplanar with its respective base, falls within the periphery of the base.

16. The method of claim 9, wherein consecutive bases do not abut.

10 17. A method of making a coated abrasive article comprising the steps of:

(a) introducing a slurry containing a mixture of a binder and a plurality of abrasive grains onto a surface of a backing;

(b) introducing a production tool to the surface of the backing on which the slurry has been introduced to form an intermediate article, wherein the production tool is shaped to include a plurality of protruding units distributed in two dimensions, wherein each protruding unit has a base that has a periphery, wherein, for each unit, its respective distal region, when projected on to a plane that is coplanar with its respective base, falls within the periphery of the base, and defines an offset vector between the projection of the distal region and a center point of the base; and

15 20

wherein the offset vectors for the plurality of protruding units do not exhibit a sum that approaches a limit of zero;

(c) at least partially curing the binder before the intermediate article departs from the production tool to form a coated abrasive article; and

25 (d) removing the coated abrasive article from the production tool.

18. The method of claim 17, wherein each distal region is linear.

19. The method of claim 18, wherein each distal linear region is rectilinear.

30

20. The method of claim 18, wherein each distal linear region is curvilinear.

21. The method of claim 17, wherein each base is a parallelogram.

5 22. The method of claim 21, wherein none of the sides of the parallelogram is parallel to an edge of an article upon which the abrasive array is disposed.

23. The method of claim 17, wherein for each unit, its respective distal region, when projected on to a plane that is coplanar with its respective base, falls within the periphery of the base.

10

24. The method of claim 17, wherein consecutive bases do not abut.

25. A method of making a coated abrasive article comprising the steps of:

15 (a) introducing a slurry containing a mixture of a binder and a plurality of abrasive grains onto a production tool, wherein the production tool is shaped to include a plurality of protruding units distributed in two dimensions, wherein each protruding unit has a base that has a periphery, wherein, for each unit, its respective distal region, when projected on to a plane that is coplanar with its respective base, falls within the periphery of the base, and defines an offset vector between the projection of the distal region and a center point of the base; and

20

wherein the offset vectors for the plurality of protruding units do not exhibit a sum that approaches a limit of zero;

25 (b) introducing a backing to the outer surface of the production tool such that the slurry wets one side of the backing to form an intermediate article;

(c) removing the intermediate article from the production tool; and

(d) curing the binder to form a coated abrasive article.

30

26. The method of claim 25, wherein each distal region is linear.

27. The method of claim 26, wherein each distal region is rectilinear.

28. The method of claim 26, wherein each distal region is curvilinear.

29. The method of claim 25, wherein each base is a parallelogram.

5

30. The method of claim 29, wherein none of the sides of the parallelogram is parallel to an edge of an article upon which the abrasive array is disposed.

31. The method of claim 25, wherein for each unit, its respective distal region, when projected on to a plane that is coplanar with its respective base, falls within the periphery of the base.

10

32. The method of claim 25, wherein consecutive bases do not abut.

15

33. A method of making a coated abrasive article comprising the steps of:

(a) introducing a slurry containing a mixture of a binder and a plurality of abrasive grains onto a surface of a backing;

(b) introducing a production tool to the surface of the backing on which the slurry has been introduced to form an intermediate article, wherein the production tool is shaped to include a plurality of protruding units distributed in two dimensions,

20

wherein each protruding unit has a base that has a periphery,

wherein, for each unit, its respective distal region, when projected on to a plane that is coplanar with its respective base, falls within the periphery of the base, and defines an offset vector between the projection of the distal region and a center point of the base; and

25

wherein the offset vectors for the plurality of protruding units do not exhibit a sum that approaches a limit of zero;

(c) removing the intermediate article from the production tool; and

(d) curing the binder to form a coated abrasive article.

30

34. The method of claim 33, wherein each distal region is linear.

35. The method of claim 34, wherein each distal region is rectilinear.

36. The method of claim 34, wherein each distal region is curvilinear.

5

37. The method of claim 33, wherein each base is a parallelogram.

38. The method of claim 37, wherein none of the sides of the parallelogram is parallel to an edge of an article upon which the abrasive array is disposed.

10

39. The method of claim 33, wherein for each unit, its respective distal region, when projected on to a plane that is coplanar with its respective base, falls within the periphery of the base.

15

40. The method of claim 33, wherein consecutive bases do not abut.



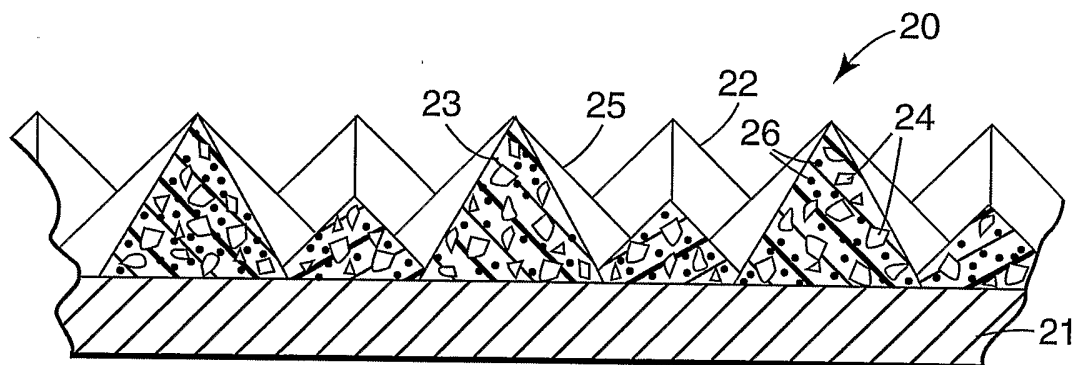


Fig. 1

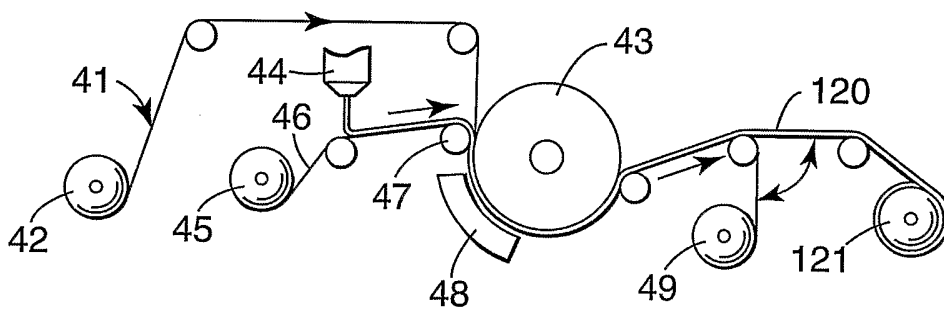


Fig. 2

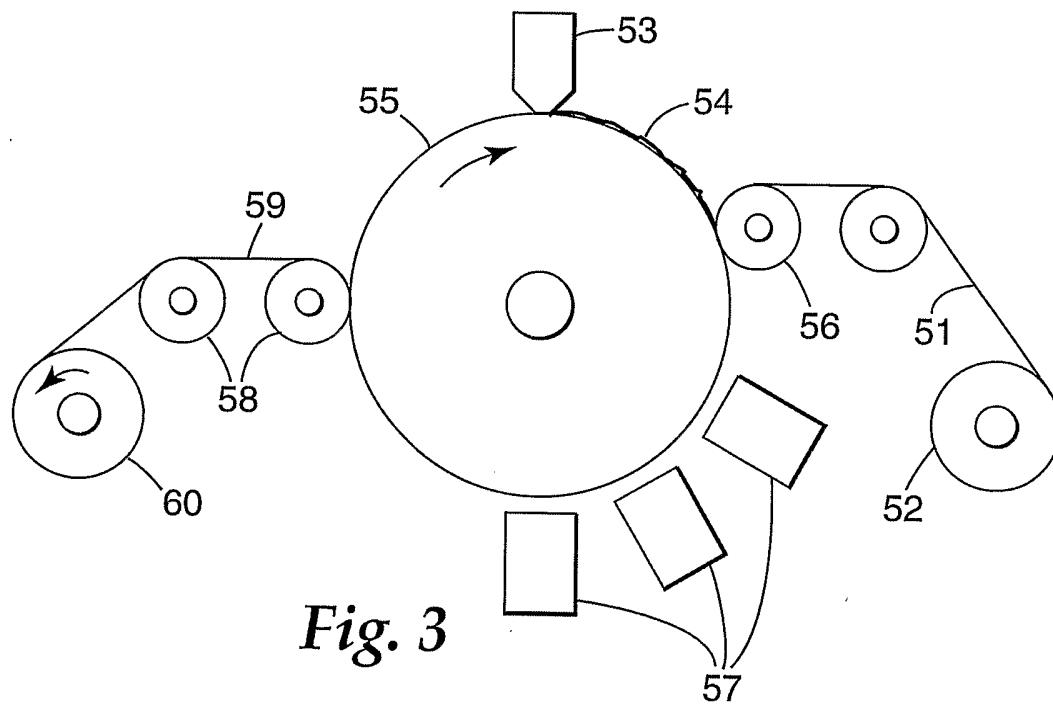
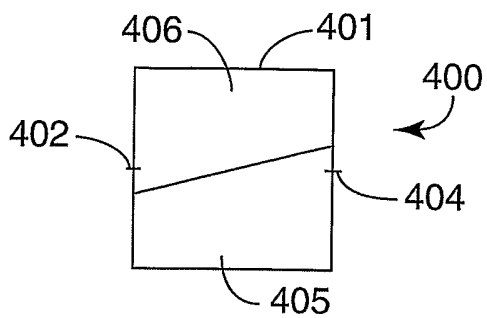
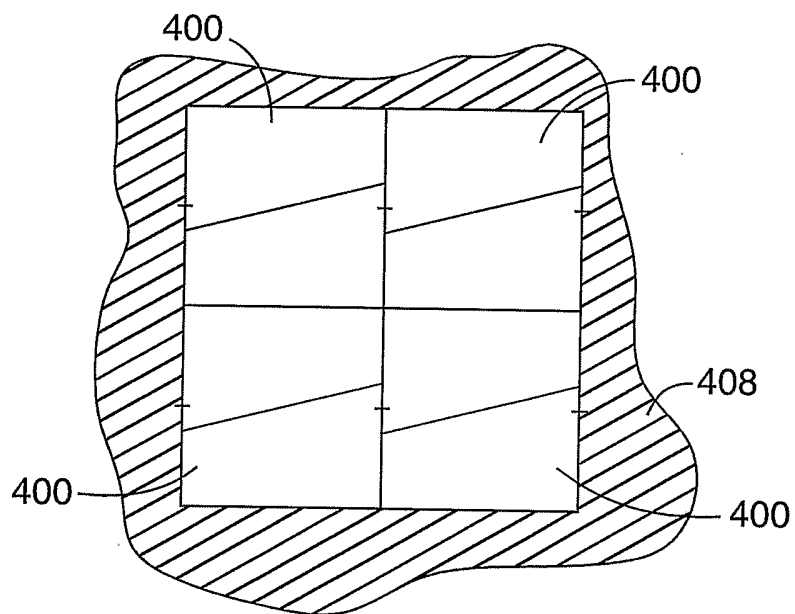


Fig. 3

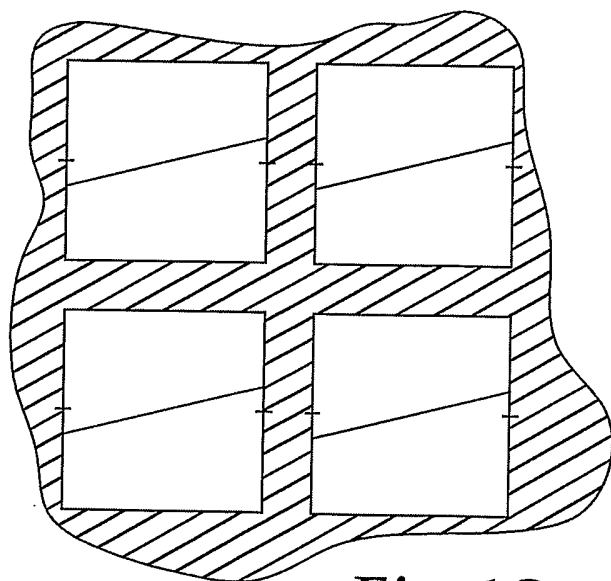
2/4



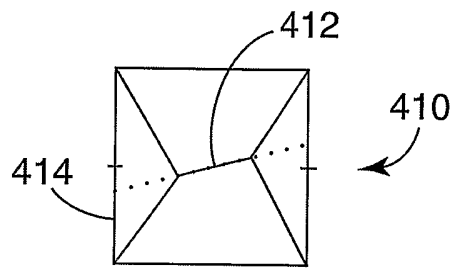
**Fig. 4A**



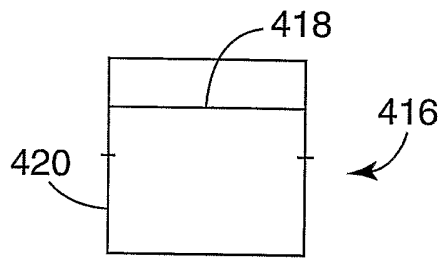
**Fig. 4B**



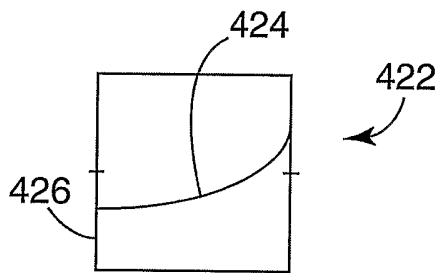
**Fig. 4C**



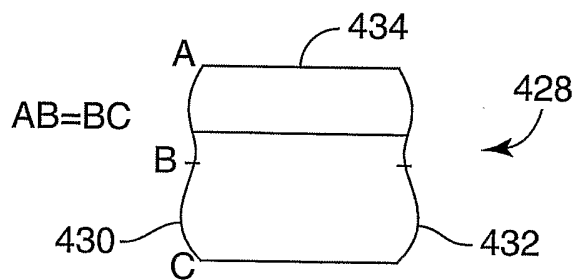
**Fig. 4D**



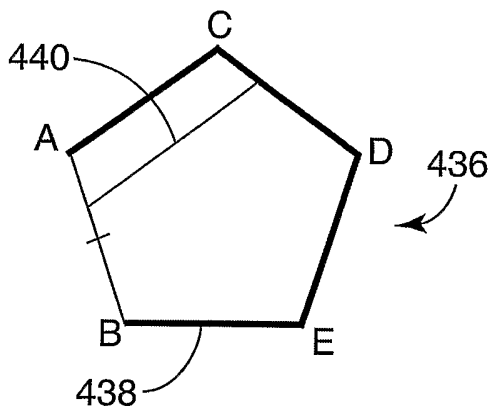
**Fig. 4E**



**Fig. 4F**

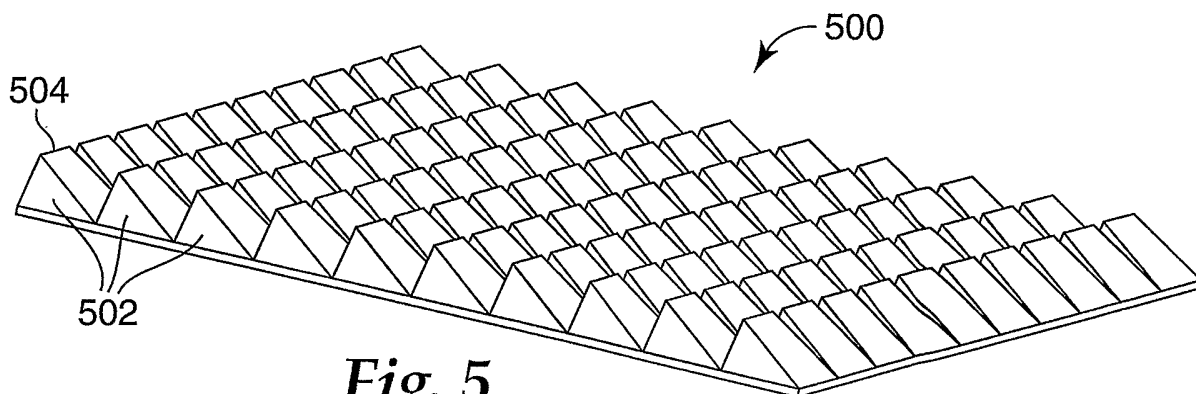


**Fig. 4G**

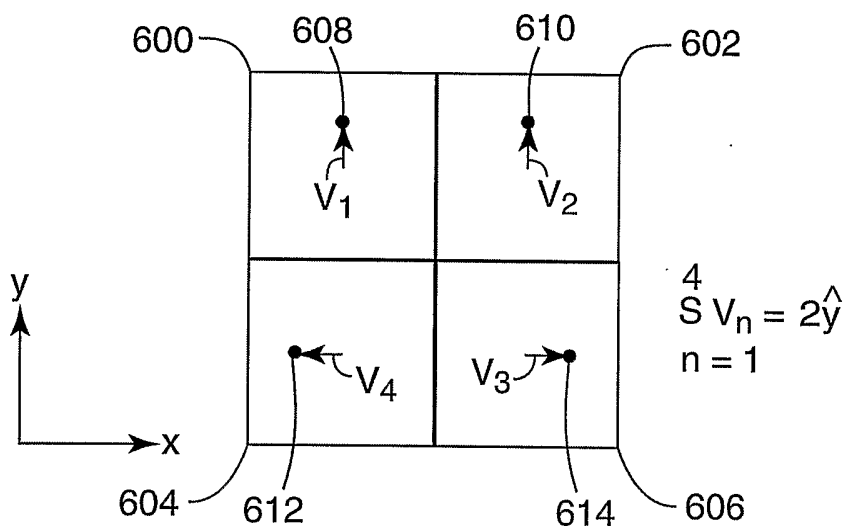


**Fig. 4H**

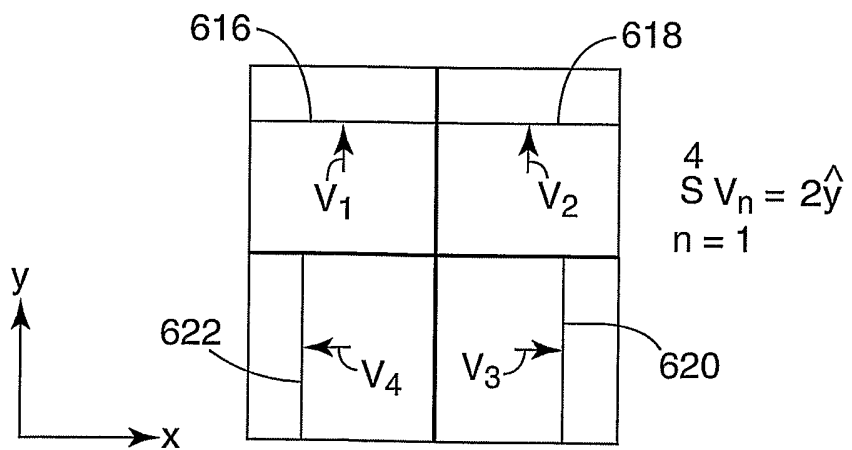
4/4



**Fig. 5**



**Fig. 6A**



**Fig. 6B**

# INTERNATIONAL SEARCH REPORT

International Application No  
PCT/US2004/024137

<b>A. CLASSIFICATION OF SUBJECT MATTER</b> IPC 7 B24D11/00		
According to International Patent Classification (IPC) or to both national classification and IPC		
<b>B. FIELDS SEARCHED</b>		
Minimum documentation searched (classification system followed by classification symbols) IPC 7 B24D		
Documentation searched other than minimum documentation to the extent that such documents are included in the fields searched		
Electronic data base consulted during the international search (name of data base and, where practical, search terms used) EPO-Internal, WPI Data, PAJ		
<b>C. DOCUMENTS CONSIDERED TO BE RELEVANT</b>		
Category °	Citation of document, with indication, where appropriate, of the relevant passages	Relevant to claim No.
X	US 6 129 540 A (HOOPMAN TIMOTHY L ET AL) 10 October 2000 (2000-10-10)  column 4, line 50 - column 26, line 58; figures 1-4,7,8	1,7-9, 15-17, 23-25, 31-33, 39,40
A	US 5 152 917 A (HOLMES GARY L ET AL) 6 October 1992 (1992-10-06) cited in the application the whole document	1-40
A	US 5 863 306 A (ALLEN KEVIN BRUCE ET AL) 26 January 1999 (1999-01-26)	
A	US 6 224 465 B1 (MEYER STUART L) 1 May 2001 (2001-05-01)	
<input type="checkbox"/> Further documents are listed in the continuation of box C.		
<input checked="" type="checkbox"/> Patent family members are listed in annex.		
° Special categories of cited documents :		
*A* document defining the general state of the art which is not considered to be of particular relevance *E* earlier document but published on or after the international filing date *L* document which may throw doubts on priority claim(s) or which is cited to establish the publication date of another citation or other special reason (as specified) *O* document referring to an oral disclosure, use, exhibition or other means *P* document published prior to the international filing date but later than the priority date claimed		
*T* later document published after the international filing date or priority date and not in conflict with the application but cited to understand the principle or theory underlying the invention *X* document of particular relevance; the claimed invention cannot be considered novel or cannot be considered to involve an inventive step when the document is taken alone *Y* document of particular relevance; the claimed invention cannot be considered to involve an inventive step when the document is combined with one or more other such documents, such combination being obvious to a person skilled in the art. *8* document member of the same patent family		
Date of the actual completion of the international search	Date of mailing of the international search report	
11 November 2004	19/11/2004	
Name and mailing address of the ISA European Patent Office, P.B. 5818 Patentlaan 2 NL - 2280 HV Rijswijk Tel. (+31-70) 340-2040, Tx. 31 651 epo nl, Fax: (+31-70) 340-3016	Authorized officer  Koller, S	

# INTERNATIONAL SEARCH REPORT

Information on patent family members

International Application No  
PCT/US2004/024137

Patent document cited in search report	Publication date	Patent family member(s)	Publication date
US 6129540	A	10-10-2000	US 6076248 A 20-06-2000
			US 2002009514 A1 24-01-2002
			US 2002028264 A1 07-03-2002
			AT 182502 T 15-08-1999
			AU 679968 B2 17-07-1997
			AU 6164394 A 03-04-1995
			BR 9407536 A 26-08-1997
			CA 2170989 A1 23-03-1995
			CN 1141016 A ,B 22-01-1997
			DE 69419764 D1 02-09-1999
			DE 69419764 T2 23-12-1999
			EP 0720520 A1 10-07-1996
			ES 2134930 T3 16-10-1999
			JP 9502665 T 18-03-1997
			JP 2004025445 A 29-01-2004
			NO 961011 A 13-05-1996
			RU 2124978 C1 20-01-1999
			SG 64333 A1 27-04-1999
			WO 9507797 A1 23-03-1995
			US 5658184 A 19-08-1997
			US 5672097 A 30-09-1997
			ZA 9400585 A 27-07-1995
			US 5152917
AU 661473 B2 27-07-1995			
AU 1240392 A 07-09-1992			
BR 9205596 A 26-04-1994			
CA 2100059 A1 07-08-1992			
CN 1269277 A 11-10-2000			
CN 1064830 A ,B 30-09-1992			
CZ 9301581 A3 16-02-1994			
DE 69210221 D1 30-05-1996			
DE 69210221 T2 09-01-1997			
EP 0570457 A1 24-11-1993			
ES 2086731 T3 01-07-1996			
HK 1006688 A1 12-03-1999			
HU 68648 A2 28-07-1995			
JP 3459246 B2 20-10-2003			
JP 6505200 T 16-06-1994			
JP 2004001221 A 08-01-2004			
KR 216381 B1 16-08-1999			
MX 9200306 A1 01-09-1992			
RU 2106238 C1 10-03-1998			
SG 73390 A1 20-06-2000			
US 5304223 A 19-04-1994			
WO 9213680 A1 20-08-1992			
US 5378251 A 03-01-1995			
US 5863306	A	26-01-1999	TW 389717 B 11-05-2000
			US 5833724 A 10-11-1998
			AU 713607 B2 09-12-1999
			AU 5619398 A 03-08-1998
			BR 9714259 A 18-04-2000
			CA 2276508 A1 16-07-1998
			CN 1244827 A ,B 16-02-2000
			EP 0954410 A1 10-11-1999
			HK 1024202 A1 09-08-2002
			HU 0000771 A2 28-07-2000

**INTERNATIONAL SEARCH REPORT**  
 information on patent family members

International Application No  
 PCT/US2004/024137

Patent document cited in search report	Publication date	Patent family member(s)	Publication date
US 5863306	A	ID 21768 A	22-07-1999
		JP 2000507885 T	27-06-2000
		JP 3391463 B2	31-03-2003
		NO 993338 A	06-07-1999
		NZ 335614 A	29-11-1999
		PL 334452 A1	28-02-2000
		RU 2169068 C2	20-06-2001
		WO 9830358 A1	16-07-1998
		ZA 9800016 A	02-07-1998
US 6224465	B1	01-05-2001	
		DE 19828477 A1	14-01-1999
		JP 3078783 B2	21-08-2000
		JP 11070462 A	16-03-1999
		US 6497613 B1	24-12-2002