

(12) INTERNATIONAL APPLICATION PUBLISHED UNDER THE PATENT COOPERATION TREATY (PCT)

(19) World Intellectual Property Organization
International Bureau



(43) International Publication Date
24 December 2003 (24.12.2003)

PCT

(10) International Publication Number
WO 03/105796 A1

(51) International Patent Classification⁷: A61K 7/34,
7/38, 7/32

(US). RUBICO-JAMIR, Sonia, M. [US/US]; 15 Lowell
Junction Road, Andover, MA 01810 (US). GROSZ, Ron
[US/US]; 11 Jenkins Road, Andover, MA 01810 (US).

(21) International Application Number: PCT/US03/17525

(22) International Filing Date: 4 June 2003 (04.06.2003)

(74) Agents: RICHARDS, John et al.; Ladas & Parry, 26 West
61st Street, New York, NY 10023 (US).

(25) Filing Language: English

(26) Publication Language: English

(30) Priority Data:
10/167,907 12 June 2002 (12.06.2002) US
10/237,491 9 September 2002 (09.09.2002) US

(81) Designated States (*national*): AE, AG, AL, AM, AT, AU,
AZ, BA, BB, BG, BR, BY, BZ, CA, CH, CN, CO, CR, CU,
CZ, DE, DK, DM, DZ, EC, EE, ES, FI, GB, GD, GE, GH,
GM, HR, HU, ID, IL, IN, IS, JP, KE, KG, KP, KR, KZ, LC,
LK, LR, LS, LT, LU, LV, MA, MD, MG, MK, MN, MW,
MX, MZ, NI, NO, NZ, OM, PH, PL, PT, RO, RU, SC, SD,
SE, SG, SK, SL, TJ, TM, TN, TR, TT, TZ, UA, UG, US,
UZ, VC, VN, YU, ZA, ZM, ZW.

(63) Related by continuation (CON) or continuation-in-part
(CIP) to earlier application:

US 10/237,491 (CON)
Filed on 9 September 2002 (09.09.2002)

(84) Designated States (*regional*): ARIPO patent (GH, GM,
KE, LS, MW, MZ, SD, SL, SZ, TZ, UG, ZM, ZW),
Eurasian patent (AM, AZ, BY, KG, KZ, MD, RU, TJ, TM),
European patent (AT, BE, BG, CH, CY, CZ, DE, DK, EE,
ES, FI, FR, GB, GR, HU, IE, IT, LU, MC, NL, PT, RO,
SE, SI, SK, TR), OAPI patent (BF, BJ, CF, CG, CI, CM,
GA, GN, GQ, GW, ML, MR, NE, SN, TD, TG).

(71) Applicant (*for all designated States except US*): THE
GILLETTE COMPANY [US/US]; Prudential Tower
Building, Boston, MA 02199 (US).

(72) Inventors; and

(75) Inventors/Applicants (*for US only*): COLWELL, Den-
nis, James [US/US]; 6 Van Gemert Drive, Mansfield, MA
02048 (US). ELLIOT, David, L. [US/US]; 7 Rudon Court,
North Attleboro, MA 02760 (US). MOLONEY, Michael,
J. [US/US]; 60 Mill Lane Road, Brimfield, MA 01010

Published:

— with international search report

For two-letter codes and other abbreviations, refer to the "Guidance Notes on Codes and Abbreviations" appearing at the beginning of each regular issue of the PCT Gazette.



WO 03/105796 A1

(54) Title: DEODORANT HAVING A MARBLED APPEARANCE

(57) Abstract: An antiperspirant or deodorant composition has a marbled appearance.

DEODORANT HAVING A MARBLED APPEARANCE

PERSONAL CARE PRODUCT

This invention relates to methods of manufacturing personal care products.

Antiperspirant and deodorant compositions are well known personal care products. The compositions come in a variety of forms and may be formulated, for example, into aerosols, pumps, sprays, liquids, roll-on, lotion, creams, and sticks (both
5 hard and soft), etc. There are various types of stick antiperspirant compositions. In one type, an antiperspirant salt is suspended in an anhydrous vehicle often including a solid water-insoluble wax. In a second type, an antiperspirant salt is dissolved in a liquid vehicle such as propylene glycol and gelled with a gelling agent such as dibenzylidene
10 sorbitol. A third type includes an emulsion of an aqueous phase containing the antiperspirant salt and an oil phase containing, for example, a volatile silicone, fragrances, gellants, and other additives.

Generally, the invention relates to an antiperspirant or deodorant composition having a marbled appearance. "Marbled appearance", as used herein, refers
15 to a product having an application surface that is irregularly colored with mottling or streaking. The marbled appearance is preferably two colors, one being white and the other non-white, although colors other than white and patterns having more than two colors are possible.

In one aspect, the invention features a composition having a marbled
20 appearance that includes two portions. The first portion has a first color and includes an antiperspirant salt or deodorant active. The second portion has a second color and also includes an antiperspirant salt or deodorant active.

In another aspect, the invention features a composition having a marbled
25 appearance that again includes two portions. The first portion has a first color and includes an antiperspirant salt or deodorant active. The second portion has a second color. One or both portions has a melt viscosity of at least 1200 cp at 65°C, preferably between 1500 cp and 5000 cp at 65°, and more preferably between 2000 cp and 4000 cp at 65°. Melt viscosity is measured 3°C above the melting point of the formulation at a shear rate of 1 sec⁻¹ using a TA Instruments AR-1000 rheometer. The relatively high
30 viscosity of one or both portions can provide reduced mixing of the two portions during manufacture. This controlled rate and degree of mixing achieves the marbled appearance.

In one embodiment, the first portion comprises a volatile silicone, a high

- 2 -

melting wax, and from 6 USP weight percent to 25 USP weight percent antiperspirant salt, and the second portion includes a volatile silicone, a high melting wax, and from 6 USP weight percent to 25% weight percent antiperspirant salt.

5 In another aspect the invention features a method of manufacturing an antiperspirant or deodorant product including a composition with the marbled appearance. The method includes (1) combining a first composition portion having a first color and including an antiperspirant salt with a second color and also including an antiperspirant salt or deodorant active, and (2) filling a container with the first composition portion and the second composition portion. Preferably the first and second composition portions are
10 combined before filling the container, although alternatively combining and filling can be done as one step.

In another aspect, the invention features a method of manufacturing an antiperspirant or deodorant product including a composition having a marbled appearance. The method includes (1) combining a first composition portion having a first
15 color and including an antiperspirant salt with a second composition portion having a second color, and (2) filling a container with the first composition portion and the second composition portion. The first composition portion and/or the second composition portion has a melt viscosity of at least 1200 cp at 65°C. Preferably the first and second composition portions are combined before filling the container, although alternatively the
20 combining and filling can be done as one step.

In a further aspect, the invention again features a method of manufacturing an antiperspirant or deodorant product including a composition having a marbled appearance. The method includes (1) combining a first composition portion having a first
25 color and including an antiperspirant salt with a second composition portion having a second color under predominantly laminar flow conditions and (2) filling a container with the combined first composition portion and second composition portion. "Predominantly laminar" as used herein, means filling conditions with Reynolds Number for flow that is in the transition region between laminar and turbulent flow or lower for a particular formulation. The transition from laminar to turbulent flow generally occurs at a Reynolds
30 Number between 2000 and 4000. Thus, "predominantly laminar" conditions occur at a Reynolds Number below about 4000, and preferably, below a Reynolds Number of about 2000. Predominantly laminar conditions result in minimal fluid turbulence, thereby

- 3 -

reducing mixing of the two fluid portions. The result is that the fluid portions, only partially mixed, can be cooled below their melt points, resulting in the marbled appearance.

Other features and advantages of the invention will be apparent from the description of an embodiment thereof, the drawings, and from the claims.

DESCRIPTION OF DRAWINGS

Fig 1. is a perspective view of an antiperspirant product including a composition having a marbled appearance, and

Fig. 2 is a perspective view of a process for manufacturing the antiperspirant product of Fig. 1.

Referring to Fig. 1, antiperspirant product 2 includes a container 10 and an antiperspirant composition 12 having a marbled appearance. The antiperspirant composition includes a white first portion 14 and a blue second portion 16. The portions may be partially mixed at their interfaces, but "first portion" and "second portion", as used herein, means the first portion or the second portion prior to the mixing. Of course, product 10 alternatively can also include a third portion, a fourth portion, etc., each having a different composition and color.

One or both of the portions in the antiperspirant product may include an antiperspirant salt suspended in an anhydrous, hydrophobic vehicle including a volatile silicone and/or a high melting component such as a wax.

The preferred antiperspirant salts are aluminum salts and aluminum zirconium salts. Preferred aluminum salts are those having the general formula $Al_2(OH)_{6-a}X_a$ wherein X is Cl, Br, I, or NO_3 , and a is about 0.3 to about 5, preferably about 0.8 to about 2.5, more preferably about 1 to about 2 (such that the Al to X mole ratio is about 0.9:1 to about 2.1:1). These salts generally have some water of hydration associated with them, typically on the order of 1 to 6 moles per mole of salt. Most preferably, the aluminum salt is aluminum chlorohydrate (i.e., X is Cl in the above formula), especially 5/6 basic aluminum chlorohydrate where a is about 1, such that the aluminum to chlorine mole ratio is about 1.9:1 to 2.1:1. Aluminum chlorohydrate is referred to as "ACH" herein.

Preferred aluminum-zirconium salts are mixtures or complexes of the above-described aluminum salts with zirconium salts of the formula $ZrO(OH)_{4-pb}Y_b$

- 4 -

wherein Y is Cl, Br, I, NO₃, or SO₄, b is about 0.8 to 4, and p is the valence of Y. The zirconium salts also generally have some water of hydration associated with them, typically on the order of 1 to 7 moles per mole of salt. Preferably the zirconium salt is zirconium hydroxychloride of the formula ZrO(OH)_{4-b}Cl_b, wherein b is about 0.8 to 4, preferably about 1.0 to about 4. The aluminum-zirconium salts encompassed by the present invention have an Al:Zr mole ratio of about 2 to about 10, and a metal:X+Y ratio of about 0.73 to about 2.1, preferably about 0.9 to 1.5. A preferred salt is aluminum-zirconium chlorohydrate (i.e. X and Y are Cl), which has an Al:Zr ratio of about 2 to about 10 and a metal:Cl ratio of about 0.9 to about 2.1. Thus, the term aluminum-zirconium chlorohydrate is intended to include the tri-, tetra-, penta- and octa-chlorohydrate forms. Aluminum-zirconium chlorohydrate is referred to as "AZCH" herein. Generally, the aluminum-zirconium antiperspirant salts also contain a neutral amino acid such as glycine, typically in an amount to provide a Zr:Gly ratio of about 1:1 to 4:1.

The preferred ACH and AZCH salts are of the enhanced efficacy type. By "enhanced efficacy salt" is meant an antiperspirant salt which, when reconstituted as a 10% aqueous solution, produces an HPLC chromatogram (as described, for example, in U.S. 5,330,751, which is incorporated herein by reference) wherein at least 50%, preferably at least 70%, most preferably at least 80%, of the aluminum is contained in two successive peaks, conveniently labeled peaks 3 and 4, and wherein the ratio of the area under peak 4 to the area under peak 3 is at least 0.5, preferably at least 0.7, and more preferably at least 0.9 or higher. Particularly preferred, for example, are salts wherein at least 30%, more preferably at least 40%, of the aluminum is contained in peak 4. The aluminum present in peaks 3 and 4 should be of the Al^c type, not Al^b, when analyzed by the ferron test. Enhanced efficacy aluminum chlorohydrate is referred to as "ACH" herein. Enhanced efficacy aluminum-zirconium chlorohydrate is referred to as "AZCH" herein.

HPLC analysis means that chromatograms were obtained as follows: Salt solutions are evaluated for aluminum polymer distribution by HPLC at a concentration of about 10% Al or Al-Zr salt. If the solution to be analyzed is at a higher salt concentration, it is diluted with sufficient water to bring the salt concentration to about 10%. A 1.0 μ L sample is pumped through a 4.6 mm X 500 mm column packed with Nucleosil 100-5

- 5 -

silica (Keystone Scientific Inc.) using a 0.01M aqueous nitric acid solution as the eluent. The flow rate of the mobile phase was controlled at 0.5 mL/min with an LDC/Milton Roy ConstaMetric-II metering pump (ThermoQuest Inc). HPLC profiles were recorded and processed which has a computerized system that included the Millennium 32
 5 Chromatography Manager software from the Waters Corp. A Waters 2410 differential refractometer was used as the refractive index detector. The HPLC profiles are read from left to right (higher to lower molecular weight). Following this technique, peak 3 typically appears at a retention time of 11.05-11.26 minutes ($k_d \sim 0.58-0.62$) and peak 4 typically appears at a retention time of 11.91-12.16 minutes ($k_d \sim 0.69-0.73$). Naturally, of
 10 course, other HPLC techniques which use different column materials, eluents and flow rates can be used provided that they sufficiently resolve peaks 3 and 4 with an acceptable degree of precision (i.e. the technique must be capable of resolving the Al into as least four distinct peaks). Obviously, such other techniques may place peaks 3 and 4 at different retention times from those given above.

15 An alternative enhanced efficacy antiperspirant salt are those described in U.S. Patent 6436381 issued on August 20, 2002 based on application U.S.S.N. 09/696,271, filed on October 25, 2000, which has been assigned to the same assignee as the present application and is hereby incorporated by reference. Examples of these salts are aluminum-zirconium tetrachlorohydrate or aluminum-zirconium
 20 octochlorohydrate with an HPLC peak 5 area content of at least 45%. These enhanced efficacy salts will be referred to as "E⁵AZCH" herein.

In this application, weight percent (USP) of antiperspirant salt is calculated as anhydrous weight percent in accordance with the U.S.P. method. This calculation excludes any bound water and glycine. For aluminum chlorohydrate and aluminum-
 25 zirconium chlorohydrate, the calculation is as follows:

$$\%ACH = \%Al[26.98x + 17.01(3x-1) + 35.45] / 26.98x \text{ where } x=Al/Cl$$

ratio;

$$\%AZCH = \%Al\{26.98y + 92.97 + 17.01[3y+4-(y+1)/z] + 35.45(y+1)/z\} /$$

26.98y where $y=Al/Zr$ ratio and $z=metal/Cl$ ratio.

30 For reference purposes, calculation of antiperspirant salt weight percent in accordance with the U.S.P. method compares to the previously used standard industry method is as follows: 50% ACH (std.) = 40.8% (USP); 50% AZCH (std.) = 38.5% USP.

- 6 -

A portion or both portions of the antiperspirant composition includes the antiperspirant salt in a perspiration reducing effective amount (typically at a concentration of about 3% to about 25% USP active, more typically about 6% to about 25% USP active).

5 The anhydrous, hydrophobic vehicle comprises about 60% to 95%, preferably about 70% to 90%, of a portion or the portions of the antiperspirant composition. The vehicle generally includes one or more high melting components that melt at 70°C or higher and/or a volatile silicone.

10 The high melting components may include any material suitable for use in an antiperspirant stick which melts at a temperature of about 70°C or higher. Typical of such materials are the high melting point waxes. These include beeswax, spermaceti, carnauba, bayberry, candelilla, montan, ozokerite, ceresin, and paraffin waxes, semimicrocrystalline and microcrystalline waxes, hydrogenated jojoba oil, and hydrogenated castor oil (castor wax). The preferred wax is hydrogenated castor oil. Other suitable high melting components include various types of high melting gelling
15 agents such as polyethylene-vinyl acetate copolymers, polyethylene homopolymers, 12-hydroxystearic acid, and substituted and unsubstituted dibenzylidene alditols. Polyethylene homopolymers are described in, for example, U.S. Pat. US 6,375,938, which is incorporated by reference herein. Typically, the high melting components comprise about 1 to 25%, preferably about 2 to 15%, of the composition.

20 Volatile silicones include the cyclic polydimethylsiloxanes, also known as cyclomethicones, which have from about 3 to about 6 silicon atoms, and the linear polydimethylsiloxanes, also known as dimethicones, which have from about 2 to about 9 silicon atoms. The linear volatile silicones generally have viscosities of less than about 5 centistokes at 25°C while the cyclic volatile silicones have viscosities under 10
25 centistokes; an example is DC 200, which is available from Dow Corning Corp. "Volatile" means that the material has a measurable vapor pressure at room temperature. Cyclomethicones include DC 245, DC 344, and DC 345, all of which are also available from Dow Corning Corporation. Volatile silicones are described further in U.S.S.N. 09/672,350, filed September 28, 2000, the contents of which are included in PCT
30 Publication WO 02/26204 published on April 4, 2002 which is assigned to the same assignee as the present application and is hereby incorporated by reference.

Other components may include, for example, non-volatile silicones,

- 7 -

polyhydric alcohols having 3-6 carbon atoms and 2-6 hydroxy groups, fatty alcohols having from 12 to 24 carbon atoms, fatty alcohol esters, fatty acid esters, fatty amides, non-volatile paraffinic hydrocarbons, polyethylene glycols, polypropylene glycols, polyethylene and/or polypropylene glycol ethers of C₄₋₂₀ alcohols, polyethylene and/or polypropylene glycol esters of fatty acids, and mixtures thereof. The term "fatty" is intended to include hydrocarbon chains of about 8 to 30 carbon atoms, preferably about 12 to 18 carbon atoms.

Non-volatile silicones include polyalkylsiloxanes, polyalkylaryl siloxanes, and polyethersiloxanes with viscosities of about 5 to about 100,000 centistokes at 25°C, polymethylphenylsiloxanes with viscosities of about 15 to about 65 centistokes, and polyoxyalkylene ether dimethylsiloxane copolymers with viscosities of about 1200 to about 1500 centistokes.

Useful polyhydric alcohols include propylene glycol, butylenes glycol, dipropylene glycol and hexylene glycol. Fatty alcohols include stearyl alcohol, cetyl alcohol, myristyl alcohol, oleyl alcohol, and lauryl alcohol. Fatty alcohol esters include C₁₂₋₁₅ alcohols benzoate, myristyl lactate, cetyl acetate, and myristyl octanoate. Fatty acid esters include isopropyl palmitate, myristyl myristate, and glyceryl monostearate. Fatty amides include stearamide MEA, stearamide MEA-stearate, lauramide DEA, and myristamide MIPA.

Non-volatile paraffinic hydrocarbons include mineral oils and branched chain hydrocarbons with about 16 to 68, preferably about 20 to 40, carbon atoms. An example is hydrogenated polyisobutene with about 24 carbon atoms. Suitable polyethylene glycols and polypropylene glycols will typically have molecular weights of about 500 to 6000, such as PEG-10, PEG-40, PEG-150 and PPG-20, often added as rheology modifiers to alter product appearance or sensory attributes.

Polyethylene and/or polypropylene glycol ethers or C₄₋₂₀ alcohols include PPG-10 Butanediol, PPG-14 Butyl Ether, PPG-5-Buteth-7, PPG-3-Isostearth-9, PPG-3-Myreth-3, Oleth-10, and Steareth-20. Polyethylene and/or polypropylene glycol esters of fatty acids include PEG-8 Distearate, PEG-10 Dioleate, and PPG-26 Oleate. These are generally added to give emollient properties.

The above list of materials is by way of example only and is not intended to be a comprehensive list of all potential antiperspirant stick components. Other low

- 8 -

melting waxes, non-volatile emollients and suitable components are readily identifiable to those skilled in the art. Of course, other ingredients such as colloidal silicas, particulate polyolefins, talcum materials, fragrances, colorants and preservatives may also be included as desired. For example, the composition may include up to about 10%
5 fragrance or about 2% colorant by weight.

Deodorant active ingredients may also be included as desired. A suitable deodorant active is any agent that inhibits, suppresses, masks or neutralizes malodor. These may include (1) antimicrobial or bactericidal agents which kill the bacteria responsible for malodor production, (2) agents which inhibit or suppress or interfere with
10 the bacterial enzymatic pathway that produces malodor, and (3) agents which mask or absorb or neutralize malodor. Fragrances are not considered deodorant active ingredients within the meaning of this application. Examples of deodorant actives include triclosan, triclocarban, usnic acid salts, zinc phenolsulfonate, b-chloro-D-alanine, D-cycloserine, aminoxyacetic acid, cyclodextrin, sodium bicarbonate. The composition generally may
15 comprise, by weight, about 0.01% to about 10%, preferably about 0.1% to about 6%, deodorant active.

Example

An antiperspirant composition having a marbled appearance included two portions (one blue, one white) having the following formulas:

- 9 -

White Portion	
INGREDIENTS	% WEIGHT
PPG-14 Butyl Ether	11.00
Crodamol MM ¹	1.92
Castor Wax ²	5.00
Stearyl Alcohol	18.34
Performalene 655 ³	2
Heat to 95°C and hold 10 minutes	
Cool to 70C (69-75°C)	
PREMIX	58.89
Fragrance ⁴	0.85
Encapsulated Fragrance ⁵	2
Pour at 49-53°C	
	100.00
PREMIX	
Volatile Silicone (D5) ⁶	35.490
AZCH Powder	22.500 ⁷
Silica (Aerosil R972) ⁸	0.720
Silica (Aerosil 300) ⁹	0.180
Total	58.890

¹Myristyl myristate emollient (Croda).

²MP70 Castor Wax, a modified castor oil purchased from CasChem.

³Polyethylene homopolymer from New Phase Technology.

⁴Fragrance purchased from [IFF].

⁵Encapsulated fragrance purchased from Haarmann and Reimer.

⁶Purchased from Dow Corning (Dow Corning Fluid 245).

⁷USP wt% = 16.4-17.1%.

⁸Purchased from Degussa Corp.

⁹Purchased from Degussa Corp.

- 10 -

Blue Portion	
INGREDIENTS	% WEIGHT
PPG-14 Butyl Ether	11.00
Crodamol MM	1.92
Castor Wax	5.00
Stearyl Alcohol	18.14
Performalene 655	2
Heat to 95°C and hold 10 minutes	
Cool to 70°C (69-75°C)	
PREMIX	58.89
Fragrance 1571	0.85
Colorona Dark Blue ¹	0.20
Encapsulated Fragrance	2
	100.00
Pour at 49-53°C	
PREMIX	
Volatile Silicone (D5)	35.490
AZCH	22.500
SILICA (R972)	0.720
SILICA (300)	0.180
Total	58.890

¹Pigment/colorant, purchased from Rona, a division of EM Chemicals.

The white portion and the blue portion are prepared as follows.

The white portion is prepared by mixing the components of the premix (the volatile silicone, the AZCH, and the two silicas) followed by a homogenization step. The stearyl alcohol, the castor wax, the Crodamol MM (myristyl myristate), and the PPG-14 butyl ether are heated to about 95°C to form a molten homogeneous mix. The molten mix is cooled to about 74°C. The premix is then added to the mix while holding the temperature at between 68°C and 62°C. The mix is then cooled to about 62°C, and the fragrance is added. The completed formulation is then cooled to about 52°C and then combined with the blue portion (described below).

The blue portion is prepared similarly to the white portion. To the molten stearyl alcohol, castor wax, Crodamol MM, and PPG-14 butyl ether is added the homogenized premix of the volatile silicone, the AZCH, and the two silicas, holding the temperature between 68°C and 74°C. The mix is then cooled to about 62°C, and the free oil fragrance, encapsulated fragrance, and pigment (Colorona Dark Blue) are added. The mix is cooled to about 52°C and combined with the white portion.

Referring to Fig. 2, the white portion and blue portion are delivered by servomotor driven piston metering pumps 10 and 16, respectively, Hibar model

- 11 -

4S3RV100) into lines 12 and 18. Pumps 10 and 16 are electronically geared to one another to deliver the appropriate quantities of the white and blue portion. The portions preferably are delivered at ratios of white portion:blue portion of from 2:1 to 8:1, for example, 4:1. All product contact surfaces in the process are controlled to maintain the product in a molten state.

The white portion and blue portion are combined in static mixer 14. The static mixer may be, for example, from 2-12 Kenics-type elements available from Chemineer, Inc. or 2-8 Koch SMX-type elements available from Koch-Glitsch, Inc. In the procedure illustrated in Fig. 2, Kenics-type elements having a diameter of $\frac{5}{8}$ " were used. The number of elements, and the fill rate (discussed below) are selected to maintain a predominantly laminar flow of the two portions and to minimize turbulent zones. The streams of the white portion and the blue portion are introduced parallel or at a low angle into the static mixer. The static mixer reduces smoothly to nozzle tip 20, which has an opening diameter of 0.35 in. Nozzle tip 20 begins the process about 10 mm above the factor seal in container 10 and is retracted during filling to maintain a 10 mm distance above the composition. The fill cycle time can be, for example, from 6 to 10 seconds, resulting in flow rates of from about 380 ml/min to 650 ml/min.

The specific marbled pattern can be varied as desired by adjusting the number of mixing elements, the flow rate through the nozzle, the nozzle diameter, and formulation viscosity.

A number of embodiments of the invention have been described. Nevertheless, it will be understood that various modifications may be made without departing from the spirit and scope of the invention. Accordingly, other embodiments are within the scope of the following claims.

- 12 -

CLAIMS

1. A product for underarm application, comprising
a container, and
a composition, within the container, having an application surface having a
5 marbled appearance, the composition including a first portion having a first color and
including an antiperspirant salt and/or a deodorant active, and a second portion having a
second color and also including an antiperspirant salt and/or deodorant active.
2. The product of claim 1, wherein the first portion and the second portion
each comprises at least 6 USP weight percent of the antiperspirant salt.
- 10 3. The product of claim 1, wherein the first portion comprises a volatile
silicone, a high melting wax, and from 6 USP weight percent to 25 USP weight percent
antiperspirant salt, and the second portion comprises a volatile silicone, a high melting
wax, and from 6 USP weight percent to 25% weight percent antiperspirant salt.
4. The product of any of claims 1, 2 or 3 wherein the first portion has a melt
15 viscosity of at least 1200 cp at 65°C.
5. The product of claim 4, wherein the first portion has a melt viscosity of
between 1500 cp and 5000 cp at 65°.
6. The product of claim 5, wherein the first portion has a melt viscosity of
between 2000 cp and 4000 cp at 65°C.
- 20 7. The product of claim 4, wherein the second portion also has a melt
viscosity of at least 1200 cp at 65°C.
8. A product for underarm application, comprising
a container, and
a composition, within the container, having an application surface having a
25 marbled appearance, the composition including a first portion having a first color and
including an antiperspirant salt and/or deodorant active, and a second portion having a
second color,
wherein said first portion and/or said second portion has a melt viscosity of
at least 1200 cp at 65°C.
- 30 9. The product of claim 8, wherein the first portion and the second portion
each comprises at least 6 USP weight percent of the antiperspirant salt.
10. The product of claim 8, wherein the first portion comprises a volatile

- 13 -

silicone, a high melting wax, and from 6 USP weight percent to 25 USP weight percent antiperspirant salt, and the second portion comprises a volatile silicone, a high melting wax, and from 6 USP weight percent to 25% weight percent antiperspirant salt.

- 5 11. The product of claim 8, wherein said first and/or said second portion has a melt viscosity of between 1500cp and 5000 cp at 65°C.
12. The product of claim 8, wherein said first and/or said second portion has a melt viscosity of between 2000cp and 4000 cp at 65°C.
13. The product of any of claims 8 - 12, wherein said first portion and second portion each has a melt viscosity of at least 1200 cp at 65°C.
- 10 14. The product of claim 13, wherein said first portion and said second portion each has a melt viscosity of between 1500 and 5000 cp at 65°C.
15. The product of claim 14, wherein said first portion and said second portion each has a melt viscosity of between 2000 cp and 4000 cp at 65°C.
- 15 16. A method of manufacturing an antiperspirant or deodorant product comprising a composition having a marbled appearance within a container, the method comprising
- combining a first composition portion having a first color and including an antiperspirant salt or a deodorant active with a second composition portion having a second color and also including an antiperspirant salt or deodorant active; and
- 20 filling the container with the first composition portion and the second composition portion to provide the composition having the marbled appearance.
17. The method of claim 16, wherein the first composition portion and the second composition portion are combined prior to filling the container.
18. The method of claim 16, wherein the first composition portion and second composition portion are combined as the container is filled.
- 25 19. The method of any of claims 16 - 18, wherein the composition portion has a melt viscosity of at least 1200 cp at 65°C.
20. A method of manufacturing an antiperspirant or deodorant product comprising a composition having a marbled appearance within a container, the method comprising
- 30 combining a first composition portion having a first color and including an antiperspirant salt or a deodorant active with a second composition portion having a

- 14 -

second color; and

filling the container with the combined first composition portion and second composition portion to provide the composition having the marbled appearance.

21. The method of claim 20, wherein the first composition portion and/or the second composition portion has a melt viscosity of at least 1200 cp at 65°C.

22. The method of claim 20, wherein the first composition portion and second composition portion have a melt viscosity of at least 1200 cp at 65°C.

23. The method of any of claims 20 - 22, wherein the first composition portion has a melt viscosity of at least 1200 cp at 65°C.

24. A method of manufacturing an antiperspirant or deodorant product comprising a composition having a marbled appearance within a container, the method comprising

combining, under predominantly laminar flow conditions, a first composition portion having a first color and including an antiperspirant salt or a deodorant active with a second composition portion having a second color; and

filling the container with the combined first composition and the second composition portion to provide the composition having the marbled appearance.

25. The method of claim 24, wherein the first composition portion and the second composition portion are combined in a static mixer.

26. The method of claim 24, wherein the second portion also includes an antiperspirant salt or deodorant active.

27. The method of claim 26, wherein the first portion and the second portion each comprises at least 6 USP weight percent of the antiperspirant salt.

28. The method of claim 24, wherein the first composition portion comprises a volatile silicone, a high melting wax, and from 6 USP weight percent to 25 USP weight percent antiperspirant salt, and the second composition portion comprises a volatile silicone, a high melting wax, and from 6 USP weight percent to 25% weight percent antiperspirant salt.

29. The method of claim 24, wherein the first composition portion and/or the second composition portion has a melt viscosity of at least 1200 cp at 65°C.

30. The method of any of claims 24 - 29, wherein the first composition portion and the second composition portion have melt viscosities of between 1500 cp and 5000 cp

- 15 -

at 65°C.

FIG. 1

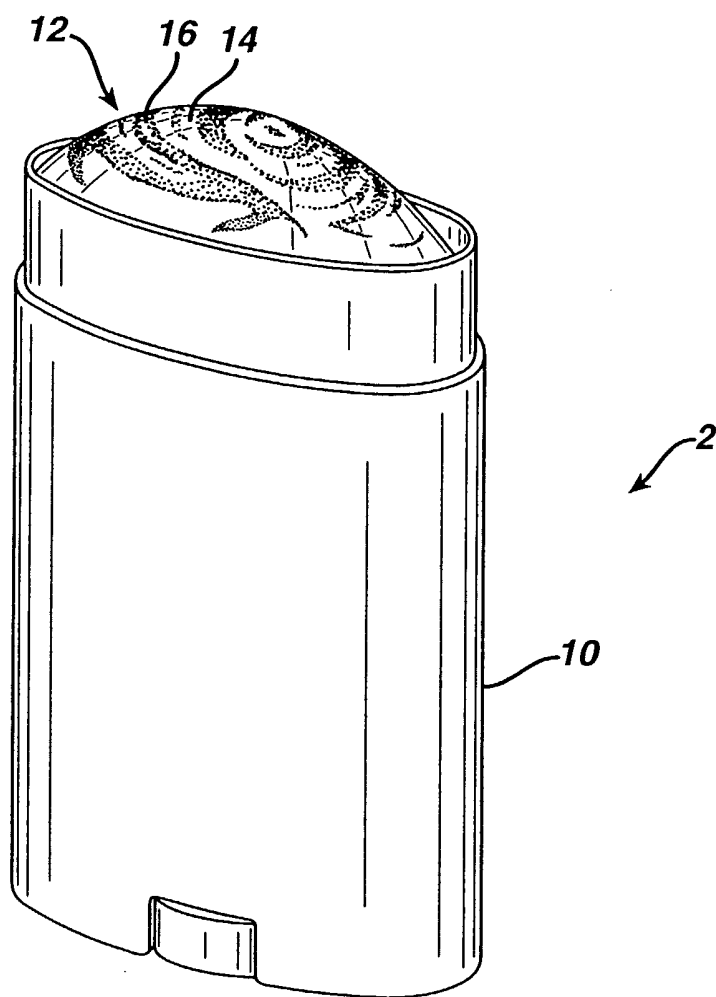
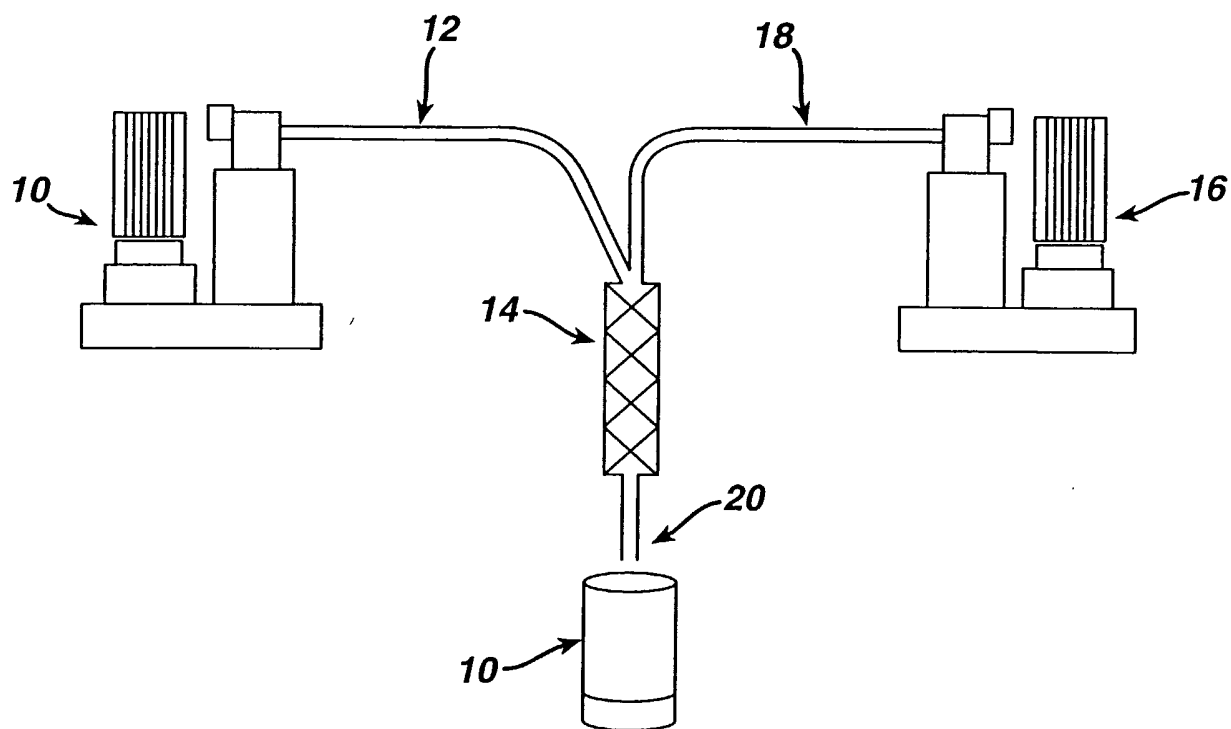

FIG. 2



INTERNATIONAL SEARCH REPORT

International Application No

PCT/US 03/17525

A. CLASSIFICATION OF SUBJECT MATTER		
IPC 7	A61K7/34	A61K7/38 A61K7/32
According to International Patent Classification (IPC) or to both national classification and IPC		
B. FIELDS SEARCHED		
Minimum documentation searched (classification system followed by classification symbols)		
IPC 7 A61K		
Documentation searched other than minimum documentation to the extent that such documents are included in the fields searched		
Electronic data base consulted during the international search (name of data base and, where practical, search terms used)		
EP0-Internal, WPI Data, PAJ		
C. DOCUMENTS CONSIDERED TO BE RELEVANT		
Category °	Citation of document, with indication, where appropriate, of the relevant passages	Relevant to claim No.
X	US D450882 S (COLWELL DENNIS JAMES ET AL) 20 November 2001 (2001-11-20) claim 1; figures 1-8 ---	1
X	US 3 479 429 A (BIAMONTE ALFRED R ET AL) 18 November 1969 (1969-11-18) column 6, line 25-29; claims 1-5 column 2, line 13-18 ---	1,8,16, 20,24
X	US 3 832 431 A (MATTHAEI R) 27 August 1974 (1974-08-27) column 1, line 36-52; claims 1,4 ---	1,8,16, 20,24
X	GB 1 013 559 A (WARNER LAMBERT PHARMACEUTICAL) 15 December 1965 (1965-12-15) page 3, line 61-64; claim 1 ---	1,8
	-/--	
<input checked="" type="checkbox"/> Further documents are listed in the continuation of box C. <input checked="" type="checkbox"/> Patent family members are listed in annex.		
° Special categories of cited documents :		
A document defining the general state of the art which is not considered to be of particular relevance *E* earlier document but published on or after the international filing date *L* document which may throw doubts on priority claim(s) or which is cited to establish the publication date of another citation or other special reason (as specified) *O* document referring to an oral disclosure, use, exhibition or other means *P* document published prior to the international filing date but later than the priority date claimed *T* later document published after the international filing date or priority date and not in conflict with the application but cited to understand the principle or theory underlying the invention *X* document of particular relevance; the claimed invention cannot be considered novel or cannot be considered to involve an inventive step when the document is taken alone *Y* document of particular relevance; the claimed invention cannot be considered to involve an inventive step when the document is combined with one or more other such documents, such combination being obvious to a person skilled in the art. *&* document member of the same patent family		
Date of the actual completion of the international search		Date of mailing of the international search report
5 September 2003		11/09/2003
Name and mailing address of the ISA European Patent Office, P.B. 5818 Patentlaan 2 NL - 2280 HV Rijswijk Tel. (+31-70) 340-2040, Tx. 31 651 epo nl, Fax: (+31-70) 340-3016		Authorized officer Yon, J-M

INTERNATIONAL SEARCH REPORT

International Application No
PCT/US 03/17525

C.(Continuation) DOCUMENTS CONSIDERED TO BE RELEVANT		
Category °	Citation of document, with indication, where appropriate, of the relevant passages	Relevant to claim No.
X	EP 0 116 406 A (MENNEN CO) 22 August 1984 (1984-08-22) page 21, line 20-26; examples 1-10 ---	1,8
A	US 3 769 225 A (MATTHAEI R) 30 October 1973 (1973-10-30) the whole document -----	16-30

INTERNATIONAL SEARCH REPORT

Information on patent family members

International Application No

PCT/US 03/17525

Patent document cited in search report		Publication date	Patent family member(s)	Publication date
US D450882	S	20-11-2001	US D450882 S1	20-11-2001
US 3479429	A	18-11-1969	US 3228662 A CH 478566 A DE 1467730 A1 DK 122305 B FR 1461802 A GB 1111789 A NL 6515437 A	11-01-1966 30-09-1969 20-02-1969 21-02-1972 22-02-1967 01-05-1968 27-07-1966
US 3832431	A	27-08-1974	CA 892530 A DE 2054865 A1 GB 1316477 A MY 15478 A	24-06-1971 09-05-1973 31-12-1978
GB 1013559	A	15-12-1965	BE 647759 A CH 456046 A DE 1492241 A1 DK 109105 C FR 1403700 A NL 132478 C NL 6406209 A	12-11-1964 15-05-1968 12-02-1970 18-03-1968 25-06-1965 04-03-1965
EP 0116406	A	22-08-1984	CA 1231056 A1 DE 3484355 D1 EP 0116406 A2 MX 162790 A	05-01-1988 08-05-1991 22-08-1984 26-06-1991
US 3769225	A	30-10-1973	CA 969318 A1 DE 2206221 A1	17-06-1975 31-08-1972