

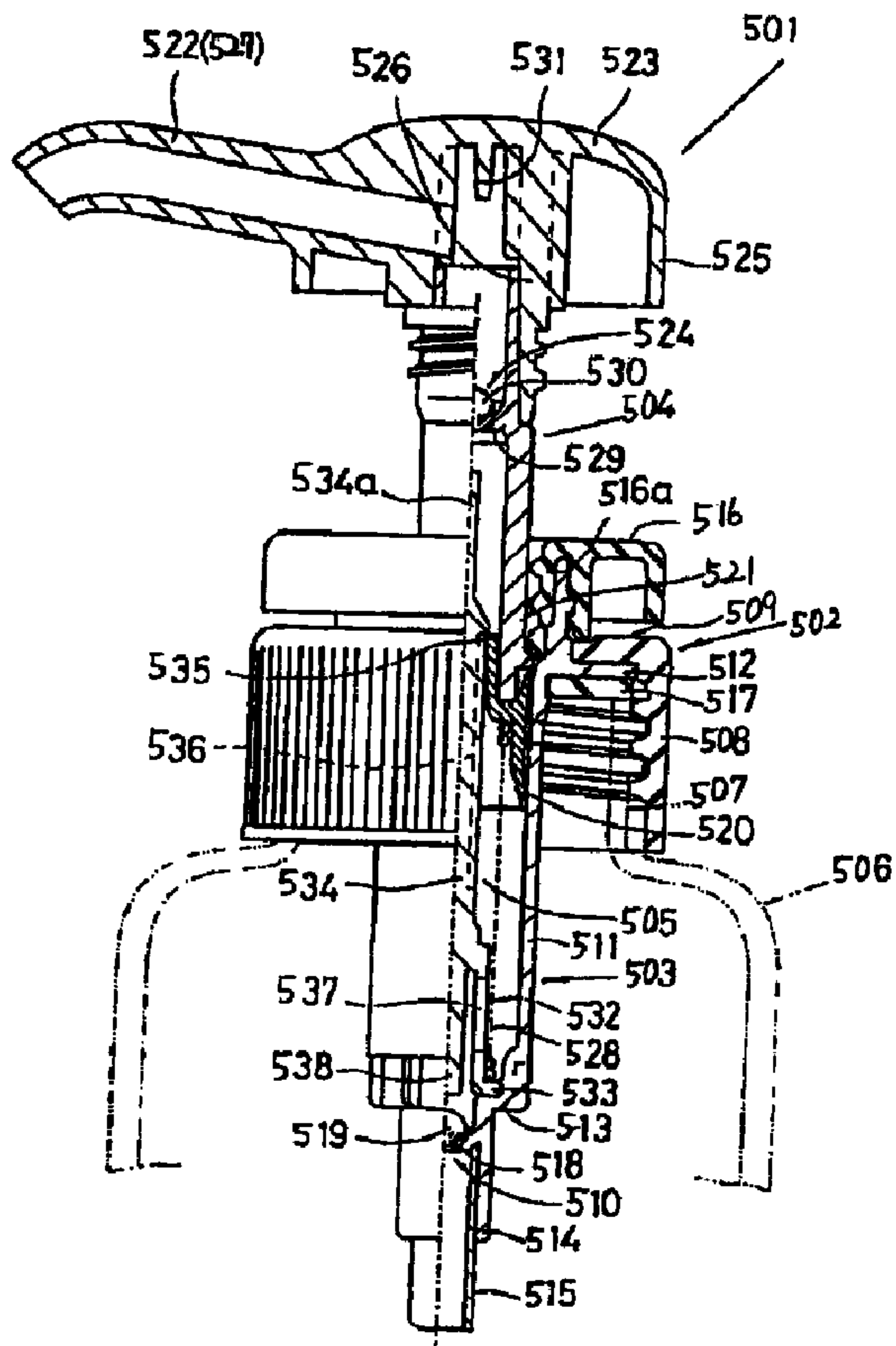

(22) Date de dépôt/Filing Date: 1996/01/26
 (41) Mise à la disp. pub./Open to Public Insp.: 1996/08/01
 (45) Date de délivrance/Issue Date: 2010/08/24
 (62) Demande originale/Original Application: 2 186 614
 (30) Priorités/Priorities: 1995/01/27 (JP7-31359);
 1995/01/27 (JP7-31358); 1995/03/29 (JP7-98109)

(51) Cl.Int./Int.Cl. *B05B 11/00* (2006.01),
B65D 47/34 (2006.01), *B65D 83/00* (2006.01),
B65D 83/76 (2006.01), *F04B 9/14* (2006.01)
 (72) Inventeurs/Inventors:
 SHIMADA, SHINJI, JP;
 KUWAHARA, KATSUHITO, JP;
 KISHI, TAKAO, JP;
 ABE, TAKAYUKI, JP;
 ENDO, SHUZO, JP;
 KOHARA, YUJI, JP;
 NOZAWA, TAKAMITSU, JP
 (73) Propriétaire/Owner:
 YOSHINO KOGYOSHO CO., LTD., JP
 (74) Agent: SMART & BIGGAR

(54) Titre : POMPE A JET POUR LIQUIDE
 (54) Title: LIQUID JET PUMP



(57) Abrégé/Abstract:

A liquid jetting pump of the present invention is constructed such that an intra container liquid is sucked into a cylinder through a suction valve by moving a vertically movable member up and down, and the intra cylinder liquid is jetted out of a nozzle through a

(57) **Abrégé(suite)/Abstract(continued):**

discharge valve from a stem. A plurality of ribs are protruded in a peripheral direction from a lower edge part within the cylinder. Engagement recessed portions are formed in inner parts of the upper surfaces of the ribs. A lower edge of a coil spring for biasing the vertically movable member is secured to each of the engagement recessed portions, thereby permitting a flow of liquid on both sides of the lower edge of the spring internally externally.

64881-475E

ABSTRACT

A liquid jetting pump of the present invention is constructed such that an intra container liquid is sucked into a cylinder through a suction valve by moving a
5 vertically movable member up and down, and the intra cylinder liquid is jetted out of a nozzle through a discharge valve from a stem. A plurality of ribs are protruded in a peripheral direction from a lower edge part within the cylinder. Engagement recessed portions are
10 formed in inner parts of the upper surfaces of the ribs. A lower edge of a coil spring for biasing the vertically movable member is secured to each of the engagement recessed portions, thereby permitting a flow of liquid on both sides of the lower edge of the spring internally externally.

64881-475E

1

Liquid Jet Pump

Technical Field

The present invention relates generally to a variety of improvements of a liquid jet pump and, more particularly, to a pump suitable for jetting a liquid exhibiting a high viscosity.

Background Art

There is a push-down head type of pump as a liquid jetting pump. For example, as illustrated in FIG. 1, a well-known pump includes a mounting cap 102 fitted to an outer periphery of a neck portion 101 of a container 100 and a cylinder 104 fixed to an interior of the container through the cap and having a suction valve 103 provided in an inner lower edge part extending downward within the container. The pump also includes a stem 106 having an annular piston 105 fitted to the interior of the cylinder and protruding from a lower part of the outer periphery thereof while being so provided as to be vertically movable in an upward biased state within the cylinder. The pump further includes a head 108 with a nozzle 107, this head being provided in continuation from an upper edge of the stem 106 and a coil spring 111 for always biasing upward a vertically movable member 110 constructed of a discharge valve 109 provided in an inner upper part of the stem, the stem and the push-down head. A liquid within the container is sucked into the cylinder 104 through the suction valve 103 by moving the vertically movable member up and down, and the intra cylinder liquid is jetted out of the tip of the nozzle 107 through the discharge valve 109 from the stem.

Further, an engagement member 112 fixedly fitted to an upper part of the cylinder is helically attached to an outer surface of the upper part of the vertically movable member in a state where the vertically movable member is pushed down. On this occasion, the lower edge part within the stem is liquid-tightly sealed by a cylindrical member 113 fixed to the lower edge of the cylinder.

Moreover, the cylinder lower edge part is reducible in diameter, and a plurality of ribs 114 are provided in a peripheral direction on the inner surface of the diameter-reducible portion. The coil spring 111 is attached by securing its

64881-475E

2

lower edge to the upper surface of each of the ribs 114 through a flange of the cylindrical member 113 and fitting its outer surface to the inner surface of the diameter-reducible portion.

In this type of conventional pump, when the vertically movable member is raised after jetting the liquid by pushing down the vertically movable member, as illustrated in FIG. 1, the liquid to be sucked into the cylinder is sucked zig-zag. If a viscosity of the liquid to be reserved is high, a suction quantity per unit time is small (conspicuous with a viscosity as high as over 4 Pa·s [4000 cps]), and, as a result, there is such an inconvenience that it takes much time from the vertically movable member to return to a maximum ascent position.

It is a first object of some embodiments of the present invention, which was contrived to obviate the defects inherent in the above prior art, to provide an excellent liquid jetting pump enabling the vertically movable member to quickly return to the ascent position even when containing the high-viscosity liquid and easy to manufacture at a low cost by modifying a slight part of structure of this type of conventional pump.

In addition to the above object, some embodiments of the present invention aim at solving the technical problems that the liquid jetting pump is desired to obviate as will hereinafter be described.

According to the conventional pump, there are disadvantages in which the liquid remaining in the nozzle after jetting the liquid drops out of the tip thereof, and the liquid remaining at the tip edge part within the nozzle is to be dry-solidified. This dry-solidification is neither desirable in appearance nor preferable because of hindering the jetting operation of the liquid as the case may be.

It is a second object of some embodiments of the present invention to provide an excellent liquid jetting pump capable of eliminating the liquid leakage and, besides, preventing the dry-solidification of the liquid as much as possible as well as providing an improvement of the prior art pump described above.

Further, in some embodiments of the present invention there is provided a pump exhibiting such an advantage that the pump can be easily

64881-475E

3

manufactured at the low cost because of being manufactured by modifying a slight part of the structure of the prior art pump.

A pump type liquid discharge container has the following defect. If the liquid contained has a relatively high viscosity, the liquid remaining within a nozzle hole after finishing the discharge of the liquid may drop out of the tip of the nozzle hole, and this liquid dropping may spoil a reliability of a consumer on the discharge container.

For eliminating the above defects, as disclosed in Japanese Utility Model Laid-Open Number 1-17976, the present applicant has applied a liquid discharge container constructed such that the bar-like portion is erected from an inner lower part of the cylinder, the upper part of the bar-like portion is inserted into the stem constituting a part of the operating member, the bar-like portion is inserted long into the stem when pushing down the operating member, the stem is negative-pressurized while removing the bar-like portion from within the stem when the operating member rises, and the liquid within the nozzle of the push-down head fitted to the upper edge of the stem can be thus sucked back.

In the above liquid discharge container, when the operating member is raised, the bar-like portion erecting from within the lower part of the cylinder is removed from within the stem, and the intra nozzle liquid is sucked back by the negative-pressuring the interior of the stem due to the removable thereof. Hence, if the operating member is insufficiently pushed down, a length of insertion of the bar-like portion inserted into the stem is also short. Accordingly, there is also insufficient negative-pressurization in the interior of the stem due to the removable of the bar-like portion when the operating member is raised, and there exists a defect in which the intra nozzle liquid is insufficiently sucked back due to the insufficient negative-pressurization.

It is another object of some embodiments of the present invention to obviate such a defect.

64881-475E

4

DE 1528606 discloses a reciprocating dispenser pump having opposed suction and discharge valves. The discharge valve is openable by the action of a stem whereas the suction valve is gravity biased to a closed position.

Disclosure of Invention

5 In accordance with an aspect of the present invention, there is provided a liquid jetting pump comprising: a mounting cap fitted to a container neck portion; a cylinder fixed to a container through the cap and including a suction valve provided in a lower edge part extending downward into the container; a stem having an annular piston fitted to an interior of the cylinder and
10 protruding from a lower part of an outer periphery, and so provided as to be vertically movable in an upward-biased state; a push-down head, with a nozzle, disposed in continuation from an upper edge of the stem and so provided as to be vertically movable above the mounting cap; and a discharge valve provided with a valve member for closing a valve hole by placing it on a valve seat provided on an
15 inner upper part of the stem, a liquid within the container being sucked into the cylinder through a suction valve, and a liquid within the cylinder being jetted out of the nozzle through the discharge valve from the stem by vertically moving a vertically movable member constructed of the stem and the push-down head, wherein a bar-like member with its upper edge part protruding into the stem is
20 provided, a tip of the bar-like member is in a lower position of the valve seat of the discharge valve in the maximum ascent position of the vertically movable member, the tip of the bar-like member protrudes with a gap along the periphery upwardly of the valve seat by pushing down the vertically movable member, and the liquid existing downstream of the discharge valve flows back upstream of the discharge
25 valve via the gap when the vertically movable member is raised, and wherein an inner lower edge of the stem includes an annular protruded portion having an inner peripheral surface that is slidably fitted to the outer periphery of the bar-like member to allow stable vertical movement of the vertically movable member and the interior of the cylinder communicates with an interior of the stem while the
30 annular protruded portion is slidably fitted to the bar-like member.

In accordance with another aspect of the present invention, there is provided a liquid jetting pump comprising: a mounting cap fitted to a container

64881-475E

5

neck portion; a cylinder fixed to a container through said cap and including a suction valve provided in a lower edge part extending downward into said container; a stem having an annular piston fitted to an interior of said cylinder and protruding from a lower part of an outer periphery, and so provided as to be

5 vertically movable in an upward-biased state; a push-down head, with a nozzle, disposed in continuation from an upper edge of said stem and so provided as to be vertically movable above said mounting cap; and a discharge valve provided with a valve member for closing a valve hole by placing it on a valve seat provided on an inner upper part of said stem, a liquid within said container being drawn into

10 said cylinder through said suction valve, and a liquid within said cylinder being jetted out of said nozzle through said discharge valve from said stem by vertically moving a vertically movable member constructed of said stem and said push-down head, wherein a bar-like member with its upper edge part protruding into said stem is provided, a tip of said bar-like member being provided in a lower

15 position below said valve seat of said discharge valve in the maximum ascent position of said vertically movable member, the tip of said bar-like member protruding with a gap along the periphery upwardly of said valve seat when said vertically movable member is pushed down, and the liquid existing downstream of said discharge valve flows back upstream of said discharge valve via the gap

20 when said vertically movable member is raised, and wherein said suction valve includes a valve member which is biased in a valve hole closing direction by a resilient member.

Brief Description of Drawings

25 FIG. 1 is a side view with some portion cut away, showing a prior art pump;

FIG. 2 is a sectional view showing a liquid jet pump;

FIG. 3(a) and 3(b) are explanatory views showing how the liquid is jetted;

FIG. 4 is a vertical sectional view showing a liquid jet pump; and

FIG. 5 is a vertical sectional view illustrating a liquid jet pump.

64881-475E

6

An embodiment of the present invention will hereinafter be discussed with reference to the drawings.

FIGS. 2, 3(a) and 3(b) illustrate a liquid jet pump, wherein the numeral 501 represents a liquid jet pump. The pump 501 includes a mounting cap 502, a cylinder 503, a vertically movable member 504 and a bar-like member 505.

The mounting cap 502 serves to fix the cylinder 503 to a container 506 and is constructed such that an inward-flange-like top wall 509 extends from an upper edge of a peripheral wall 508 helically-fitted to an outer periphery of a container cap fitted neck portion 507.

The cylinder 503 is fixed to the container 506 through the mounting cap 502 and is provided with a suction valve 510 in a lower edge portion vertically formed in the interior of the container.

The cylinder 503 has an outward flange 512 protruding outward from the outer peripheral upper portion of a cylindrical peripheral wall 511, and a fitting cylindrical portion 514 extends downward from a peripheral edge of a window hole holed in the central portion of a bottom wall 513. An upper edge of a suction pipe 515 is fitted to this fitting cylindrical portion 514, and its lower portion extends vertically downward to the lower portion in the container. Further, an engagement member 516 for engaging the vertically movable member 504 in a push-down state is fixedly fitted to the upper edge portion of the peripheral wall 511. The engagement member 516 is constructed so that the fitting cylindrical portion flange fitted via a rugged engagement element to the outer periphery of the upper edge of the cylinder 503 extends inward from the rear surface of a doughnut-like top plate, and an inner cylinder 516a fitted to the inner upper edge of the cylinder 503 extends perpendicularly from the inner peripheral edge of the top plate. Also, a thread for helically fitting the vertically movable member 504 is formed along the inner periphery of the inner cylinder 516a.

Then, the outward flange 512 is placed via a packing 517 on the upper surface of the container neck portion 507 and is caught by a top wall 509 of the mounting cap 502 and by the upper surface of the container neck portion.

64881-475E

7

The suction valve 510 is constructed so that a ball-like valve member 519 is placed on a flange-like valve seat 518 descending inward obliquely so as to protrude from the inner upper edge of the fitting cylindrical portion 514.

5 The vertically movable member 504 includes a stem 521 vertically movable in an upper biased state within the cylinder 503 while an annular piston 520 fitted to the interior of the cylinder protrudes from the outer peripheral lower portion. The vertically movable member 504 also includes a push-down head 523 with a nozzle 522 attached to the upper edge of the stem 521, and a discharge valve 524 is provided in the inner upper portion of the stem 521.

10 The push-down head 523 has a cylindrical casing 525 with an opening formed in the lower edge surface and a peripheral wall perpendicularly extending from the peripheral edge of the top wall, and a lower edge of a vertical cylinder 526 vertically extending from the center of the top wall lower surface of the casing 525 is attached to the outer peripheral upper edge of the stem 521,
15 thus fixing it to the stem 521. Further, a horizontal cylinder 527 with its proximal portion opened to the upper front surface of the vertical cylinder 526 penetrates the casing peripheral wall and protrudes forward therefrom, thus forming this horizontal cylinder 527 as a nozzle 522. The nozzle 522 is constructed so that its proximal portion ascends obliquely forward, while its tip descends obliquely. With
20 this construction, the liquid leakage can be prevented. Furthermore, a thread formed along the outer periphery of the vertical cylinder 526 with respect to a portion protruding downward from the casing 525 meshes with the thread of the engagement member 516 when pushing down the vertically movable member 504 and is thus made possible of engagement therewith in the state where the
25 vertically movable member 504 is pushed down.

Also, a coil spring 528 is interposed between the lower surface of a mounting proximal portion of the annular piston 520 and the upper surface of a flange 533, to be mentioned later, of the bar-like member 505 and works to bias the vertically movable member upward at all times.

30 The discharge valve 524 is constructed such that a flange-like valve seat 529 descending inward obliquely protrudes in an inner upper portion of the

64881-475E

8

stem 521 and has a valve hole formed in its central portion, and the valve hole is closed by putting a ball-like valve member 530 on the valve seat 529. Further, the discharge valve 524 is so constructed as to be vertically movable up to a position in which it impinges on the lower surface of an engagement rod 531 extending
5 vertically from the top wall of the casing 525.

The bar-like member 505 is provided in such a manner that the lower edge thereof is fixed to permit the flow of liquid in the lower edge portion within the cylinder 503, and the upper edge thereof protrudes in the stem 521 to narrow the passageways in the cylinder 503 and in the stem 521, thus providing
10 smooth jetting of the liquid.

Also, the tip of the bar-like member 505 is positioned downwardly of the valve seat 529 of the discharge valve in the maximum ascent position and protrudes upwardly of the valve seat 529 with a gap along the periphery when pushing down the vertically movable member 504, and the liquid existing
15 downstream of the discharge valve 524 flows back upstream of the discharge valve via the gap when the vertically movable member 504 rises.

The bar-like member 505 has a cylindrical mounting proximal portion 532 housed in the lower portion within the cylinder 503 and having its lower edge surface opened, and a flange 533 protruding from the lower edge of the outer
20 periphery of the proximal portion 532 is fixedly fitted to the lower edge of the inner surface of the cylinder peripheral wall. Further, there erects a bar-like portion 534 extending from the upper surface of the top plate of the proximal portion 532 to the interior of the stem 521. The tip of the bar-like portion 534 is formed as a reducible diameter portion 534a, thereby making the interior of the valve hole
25 insertable with a gap formed along the periphery enough to permit the flow of liquid. Then, if the vertically movable member 504 is in the maximum ascent position by a upward biasing force given by the coil spring 528, the tip thereof is positioned under the valve seat 529 enough to maintain a closed state of the discharge valve 524. When the vertically movable member 504 is pushed down,
30 the reducible diameter portion 534a is so formed as to protrude upwardly of the valve seat 529 with a gap along the periphery. Further, on this occasion, the valve member 530 never closes so far as the protruded portion of the bar-like member

64881-475E

9

505 exists and is therefore formed closed till the tip of the bar-like member moves under the valve seat 529 even when the interior of the cylinder 503 is negative-pressurized with the ascent of the vertically movable member 504. In the meantime, the liquid in the vertical cylinder 526 flows back into the stem 521, and consequently the liquid in the nozzle 522 flows back into the vertical cylinder 526.

A dimension of an upward protrusion of the valve seat 529 of the reducible portion 534a may be properly selected. If the length and the inside diameter of the nozzle, the inside diameters of the stem and of the head vertical cylinder, and the volumetric capacity of the discharge valve member are the same as those of the conventional pump, however, a vertically movable stroke of the discharge valve member 530 may be preferably set remarkably larger than in the conventional pump. Especially, if a quantity obtained by subtracting a volumetric capacity of the valve member 530 and volumetric capacity of the reducible diameter portion 534a protruding upward of the valve seat 529 from a volumetric capacity of the passageway disposed downstream of the discharge valve in which the discharge valve member 530 vertically moves is equal to or larger than the volumetric capacity of the nozzle 522, the liquid in the nozzle flows back substantially into the vertical cylinder, whereby the liquid dropping can be well prevented. More specifically, the protrusion dimension is, though different depending on the inside diameter, etc. of the stem, selected within a range of approximately 5 mm - 30 mm.

Also, the inner peripheral surface of an annular protruded portion 535 formed along the inner lower edge of the stem 521 is slidably fitted to the outer periphery of the bar-like portion 534, thereby enabling the vertically movable member 504 to move up and down stably with no lateral deflection. On the other hand, a plurality of vertical recessed grooves 536 are formed in the peripheral direction in the outer periphery of the bar-like portion 534 excluding the reducible diameter portion 534a, and the interior of the cylinder 503 communicates via the respective recessed grooves 536 with the interior of the stem 521.

Further, a plurality of window holes 537 are holed in the peripheral direction in the peripheral wall of the mounting proximal portion 532, thus making the interior and exterior of the proximal portion 532 communicable. An

64881-475E

10

engagement rod 538 for regulating the vertical movement of the valve member 519 of the suction valve 510 extends vertically from the central portion of the top plate of the proximal portion 532.

FIG. 4 illustrates an embodiment of the present invention, wherein
5 there is provided a suction valve 510a including a valve member 519 biased by a resilient member in the valve hole closing direction at all times.

In accordance with this embodiment, the lower edge of a coil spring 539 weak in its resilience for the resilient member with its upper edge fitted to the outer periphery of the engagement rod 538 is press-fitted to the upper surface of
10 the valve member 519. Other configurations are the same as those in the embodiment discussed above.

FIG. 5 also illustrates a liquid jet pump, wherein there is provided a suction valve 510b including a suction valve member 519b having a weight that is more than twice the weight of the discharge valve member 530. Other
15 configurations are the same as those in the embodiment of FIG. 2.

Note that the respective members described above are properly selectively composed of synthetic resins, metals and materials such as particularly elastomer exhibiting an elasticity.

In the suction valve 510a in the embodiment illustrated in FIG. 4, the
20 valve member 519 is always biased in the valve hole closing direction, and hence the suction valve 510 is securely prevented from being opened till the discharge valve member 524 is closed. As a result, the suction valve 510 won't open till the discharge valve 524 is closed, and the liquid in the head vertical cylinder 526 certainly flows back upstream of the discharge valve 524. Consequently, the
25 liquid in the nozzle 522 flows back into the vertical cylinder 526.

Further, in the suction valve 510b of the pump illustrated in FIG. 5, the valve member 519b thereof has the weight that is more than twice the valve member 530, and similarly the suction valve 510 is prevented from surely being opened till the discharge valve 524 is closed.

64881-475E

11

As discussed above, according to the pump of the present invention, the lower edge thereof is fixed to the lower edge within the cylinder to permit the flow of liquid, and there is provided the bar-like member with its upper edge protruding in the stem. The tip of the bar-like member is positioned downwardly of the valve seat of the discharge valve in the maximum ascent position and protrudes upwardly of the valve seat with the gap along the periphery when pushing down the vertically movable member, and the liquid existing downstream of the discharge valve flows back upstream of the discharge valve via the gap when the vertically movable member rises. Hence, when jetting the liquid by pushing down the vertically movable member, the discharge valve member can be certainly pushed down to the predetermined position by use of the tip of the bar-like member. Further, when the interior of the cylinder is negative-pressurized with the ascent of the pushed down vertically movable member, the discharge valve member never immediately clogs the valve hole. The valve does not close till at least the tip of the bar-like member retracts downwardly of the valve seat, and, therefore, the liquid existing downstream of the discharge valve flows back into the stem disposed upstream of the discharge valve. Correspondingly, the liquid in the nozzle flows back into the head vertical cylinder, and the liquid dropping out of the nozzle tip can be thereby obviated.

Moreover, since the liquid in the nozzle flows back into the head vertical cylinder, there is caused no such inconvenience that the liquid is dry-solidified even when used for jetting the high-viscosity liquid.

Also, as described above, the discharge valve member can be controlled in terms of a time of the vertical movement thereof by use of the tip of the bar-like member, and hence the liquid dropping can be prevented without depending on whether or not the liquid has the viscosity.

Further, the pump exhibits such advantages that the pump can be constructed by modifying a slight part of structure of the conventional pump and is therefore easily manufactured at low cost.

In addition, it is possible to surely prevent the suction valve from being opened till the discharge valve is closed after the predetermined amount of

64881-475E

12

liquid flows back into the stem disposed upstream of the discharge valve through the valve hole of the discharge valve. Therefore, the liquid in the nozzle is allowed to certainly flow back into the head vertical cylinder. As a result, it is feasible to prevent both liquid dropping and liquid dry-solidification.

5 Industrial Applicability

The liquid jetting pump according to the present invention, because of having been improved as discussed above, can be utilized suitably for jetting a variety of liquids e.g. a liquid cosmetic material, and is therefore industrially applicable.

64881-475E

13

CLAIMS:

1. A liquid jetting pump comprising:

a mounting cap fitted to a container neck portion;

5 a cylinder fixed to a container through the cap and including a suction valve provided in a lower edge part extending downward into the container;

a stem having an annular piston fitted to an interior of the cylinder and protruding from a lower part of an outer periphery, and so provided as to be vertically movable in an upward-biased state;

10 a push-down head, with a nozzle, disposed in continuation from an upper edge of the stem and so provided as to be vertically movable above the mounting cap; and

a discharge valve provided with a valve member for closing a valve hole by placing it on a valve seat provided on an inner upper part of the stem,

15 a liquid within the container being sucked into the cylinder through a suction valve, and a liquid within the cylinder being jetted out of the nozzle through the discharge valve from the stem by vertically moving a vertically movable member constructed of the stem and the push-down head,

20 wherein a bar-like member with its upper edge part protruding into the stem is provided, a tip of the bar-like member is in a lower position of the valve seat of the discharge valve in the maximum ascent position of the vertically movable member, the tip of the bar-like member protrudes with a gap along the periphery upwardly of the valve seat by pushing down the vertically movable member, and the liquid existing downstream of the discharge valve flows back
25 upstream of the discharge valve via the gap when the vertically movable member is raised, and

wherein an inner lower edge of the stem includes an annular protruded portion having an inner peripheral surface that is slidably fitted to the

64881-475E

14

outer periphery of the bar-like member to allow stable vertical movement of the vertically movable member and the interior of the cylinder communicates with an interior of the stem while the annular protruded portion is slidably fitted to the bar-like member.

- 5 2. A liquid jetting pump according to claim 1, wherein the suction valve includes a valve member always biased in a valve hole closing direction by a resilient member.
3. A liquid jetting pump according to claim 1, wherein the bar-like member has a lower edge that is fixed to the cylinder.
- 10 4. A liquid jetting pump according to claim 3, wherein the lower edge of the bar-like member is opened to make an interior and an exterior of the lower edge communicable to permit the flow of liquid in the lower edge portion within the cylinder.
5. A liquid jetting pump according to claim 1, wherein the outer
15 periphery of the bar-like member includes vertical recessed grooves and the interior of the cylinder communicates with the interior of the stem via the grooves.
6. A liquid jetting pump according to claim 1, wherein the nozzle has a first predetermined volumetric capacity and a liquid passageway defined between the discharge valve and the suction valve has a second predetermined volumetric
20 capacity at least equal to the first capacity, and the tip of the bar-like member has a defined length extending above the valve seat such that it enables substantially all of the liquid remaining in the nozzle after depressing of the push-down head to drain into the liquid passageway through the gap during raising of the vertically movable member before the valve hole is closed by the valve member of the
25 discharge valve.
7. A liquid jetting pump according to claim 6, wherein the defined length is within a range of 5-30 mm.
8. A liquid jetting pump comprising:
a mounting cap fitted to a container neck portion;

64881-475E

15

a cylinder fixed to a container through said cap and including a suction valve provided in a lower edge part extending downward into said container;

5 a stem having an annular piston fitted to an interior of said cylinder and protruding from a lower part of an outer periphery, and so provided as to be vertically movable in an upward-biased state;

a push-down head, with a nozzle, disposed in continuation from an upper edge of said stem and so provided as to be vertically movable above said mounting cap; and

10 a discharge valve provided with a valve member for closing a valve hole by placing it on a valve seat provided on an inner upper part of said stem,

a liquid within said container being drawn into said cylinder through said suction valve, and a liquid within said cylinder being jetted out of said nozzle through said discharge valve from said stem by vertically moving a vertically
15 movable member constructed of said stem and said push-down head,

wherein a bar-like member with its upper edge part protruding into said stem is provided, a tip of said bar-like member being provided in a lower position below said valve seat of said discharge valve in the maximum ascent position of said vertically movable member, the tip of said bar-like member
20 protruding with a gap along the periphery upwardly of said valve seat when said vertically movable member is pushed down, and the liquid existing downstream of said discharge valve flows back upstream of said discharge valve via the gap when said vertically movable member is raised, and

wherein said suction valve includes a valve member which is biased
25 in a valve hole closing direction by a resilient member.

SMART & BIGGAR
OTTAWA, CANADA

PATENT AGENTS

1/5

FIG. 1

PRIOR ART

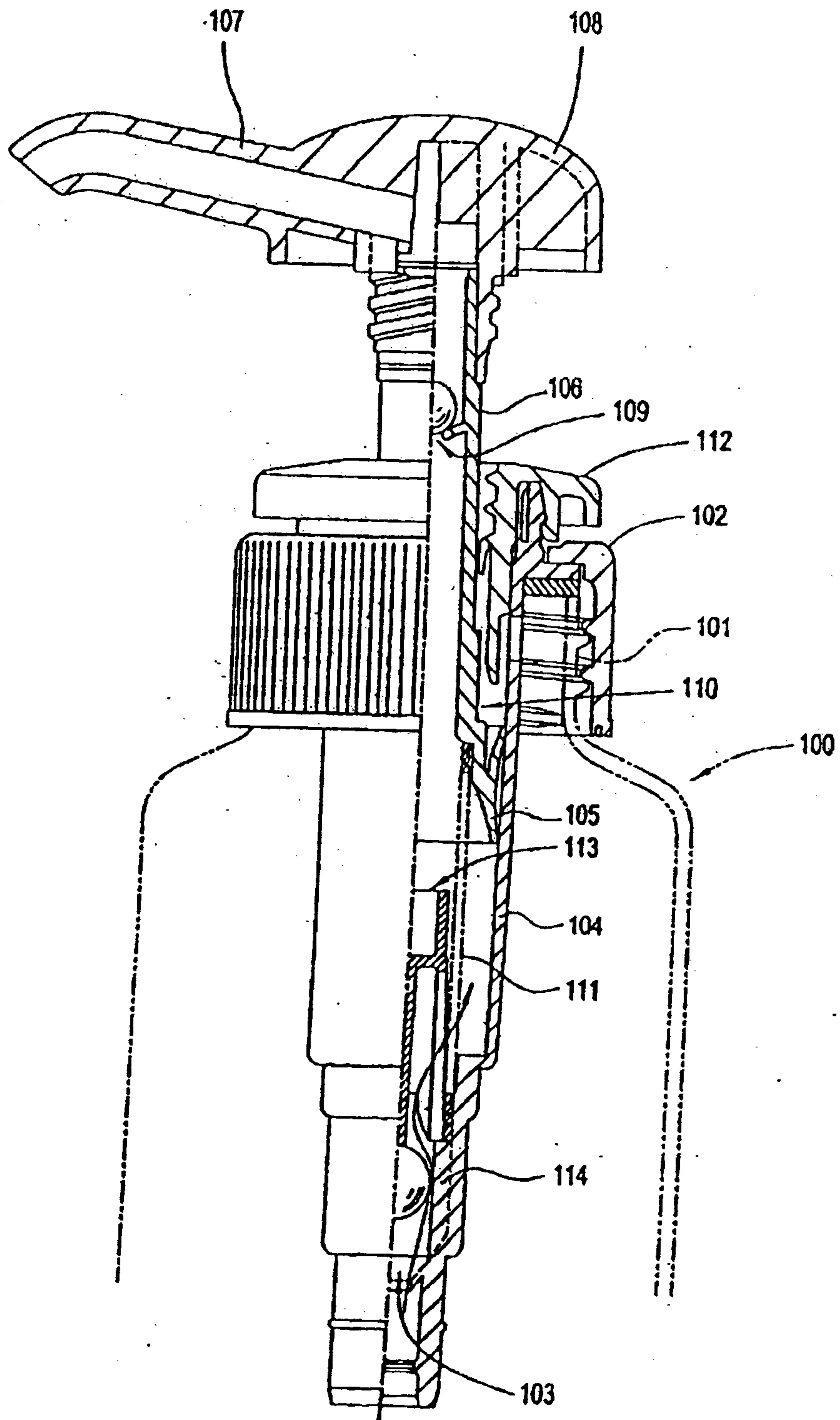

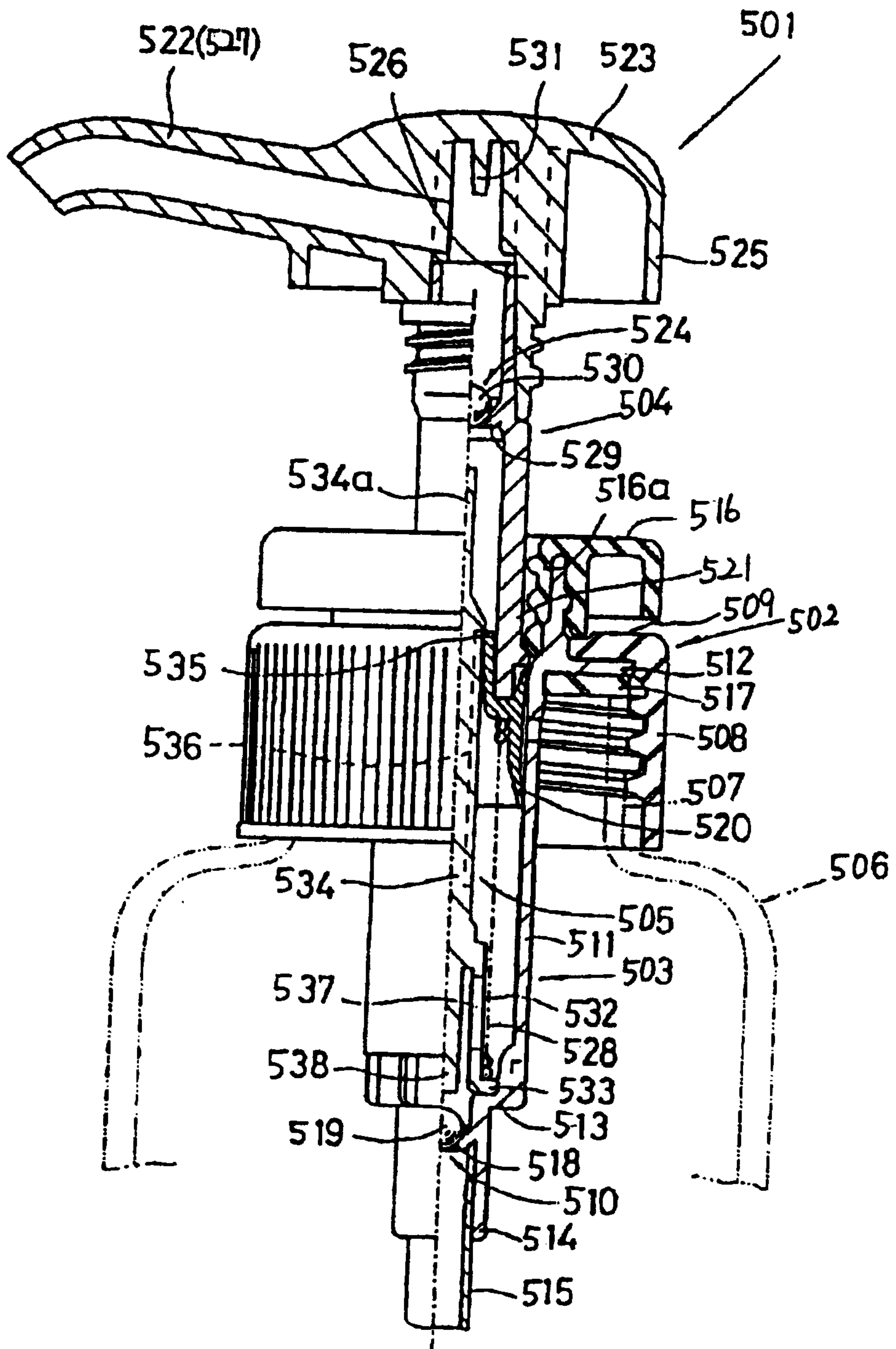

FIG. 2

3/5

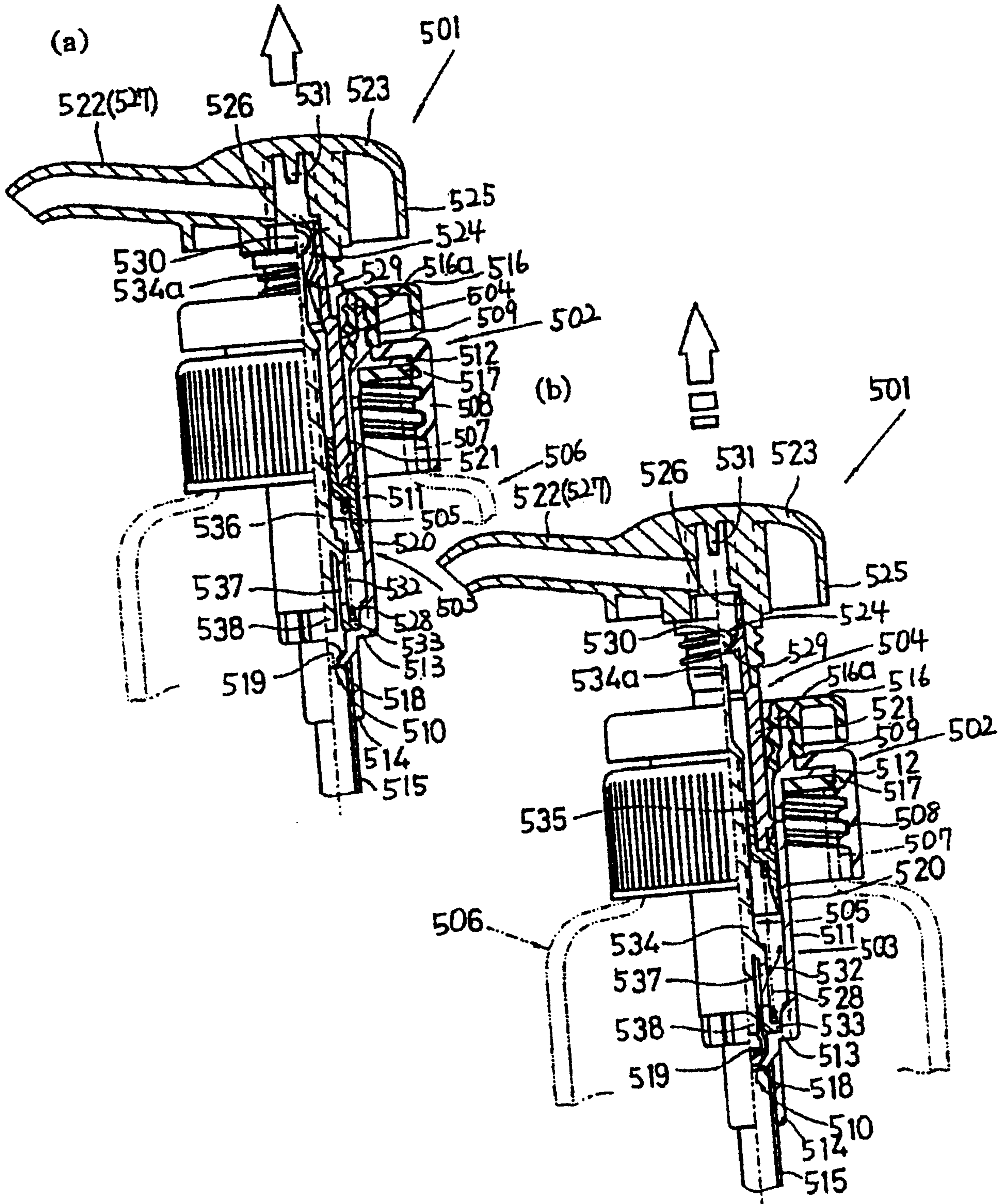

FIG. 3

4/5

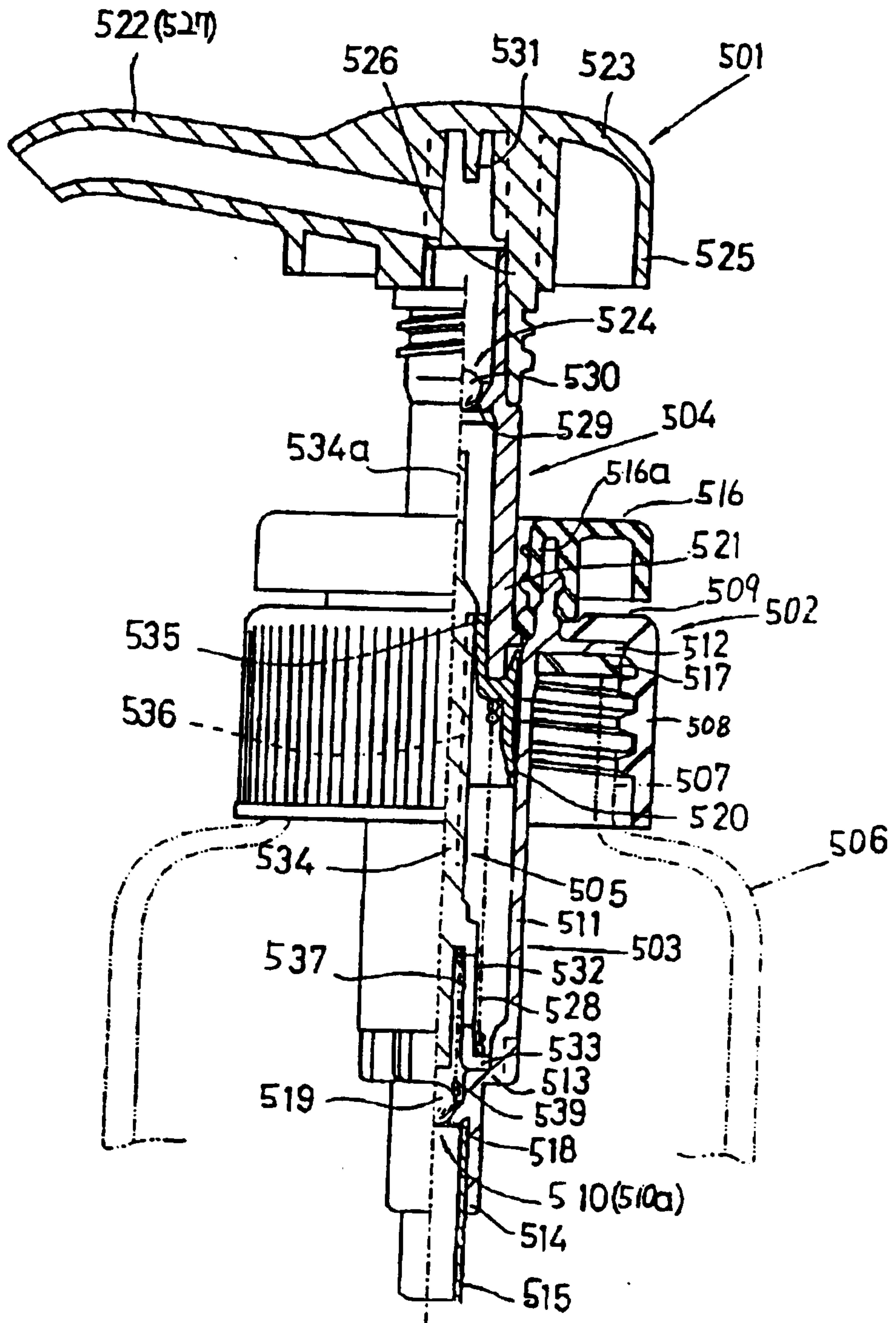

FIG. 4

5/5

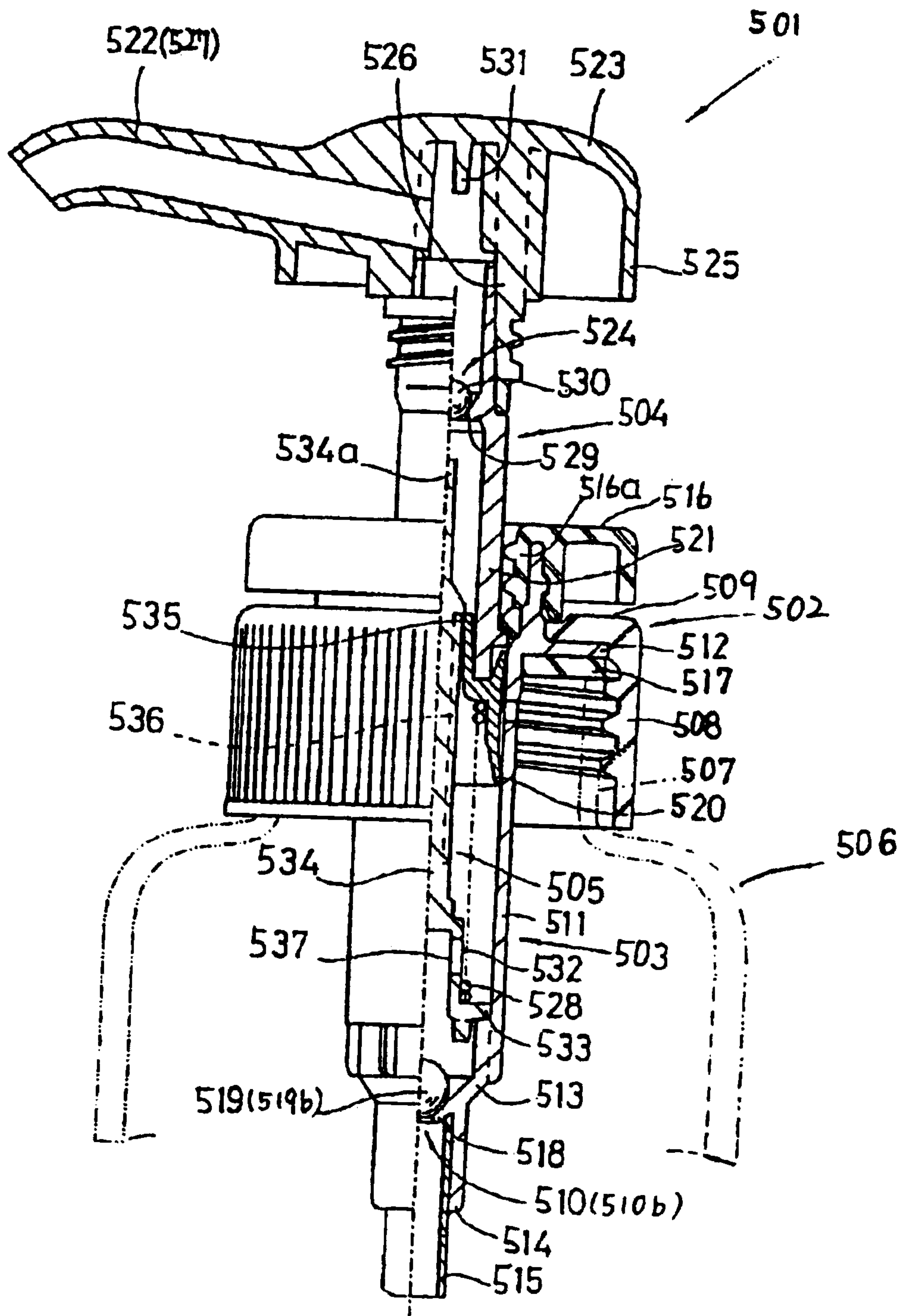

FIG. 5

