



(86) **Date de dépôt PCT/PCT Filing Date:** 2014/11/24  
 (87) **Date publication PCT/PCT Publication Date:** 2015/07/02  
 (45) **Date de délivrance/Issue Date:** 2017/12/12  
 (85) **Entrée phase nationale/National Entry:** 2016/06/16  
 (86) **N° demande PCT/PCT Application No.:** US 2014/067019  
 (87) **N° publication PCT/PCT Publication No.:** 2015/099926  
 (30) **Priorité/Priority:** 2013/12/23 (US14/139,008)

(51) **Cl.Int./Int.Cl. A61M 25/00** (2006.01),  
**A61M 25/06** (2006.01)

(72) **Inventeurs/Inventors:**  
DEVRIES, ELISE, US;  
KRUEGER, JOHN A., US;  
MASSI, SHAYNA, US;  
RAY, JOHN, US;  
DOSHI, PALAK, US

(73) **Propriétaire/Owner:**  
CAREFUSION 2200, INC., US

(74) **Agent:** AIRD & MCBURNEY LP

(54) **Titre : DISPOSITIF ET PROCÉDE DE PLEURODESE**  
 (54) **Title: PLEURODESIS DEVICE AND METHOD**

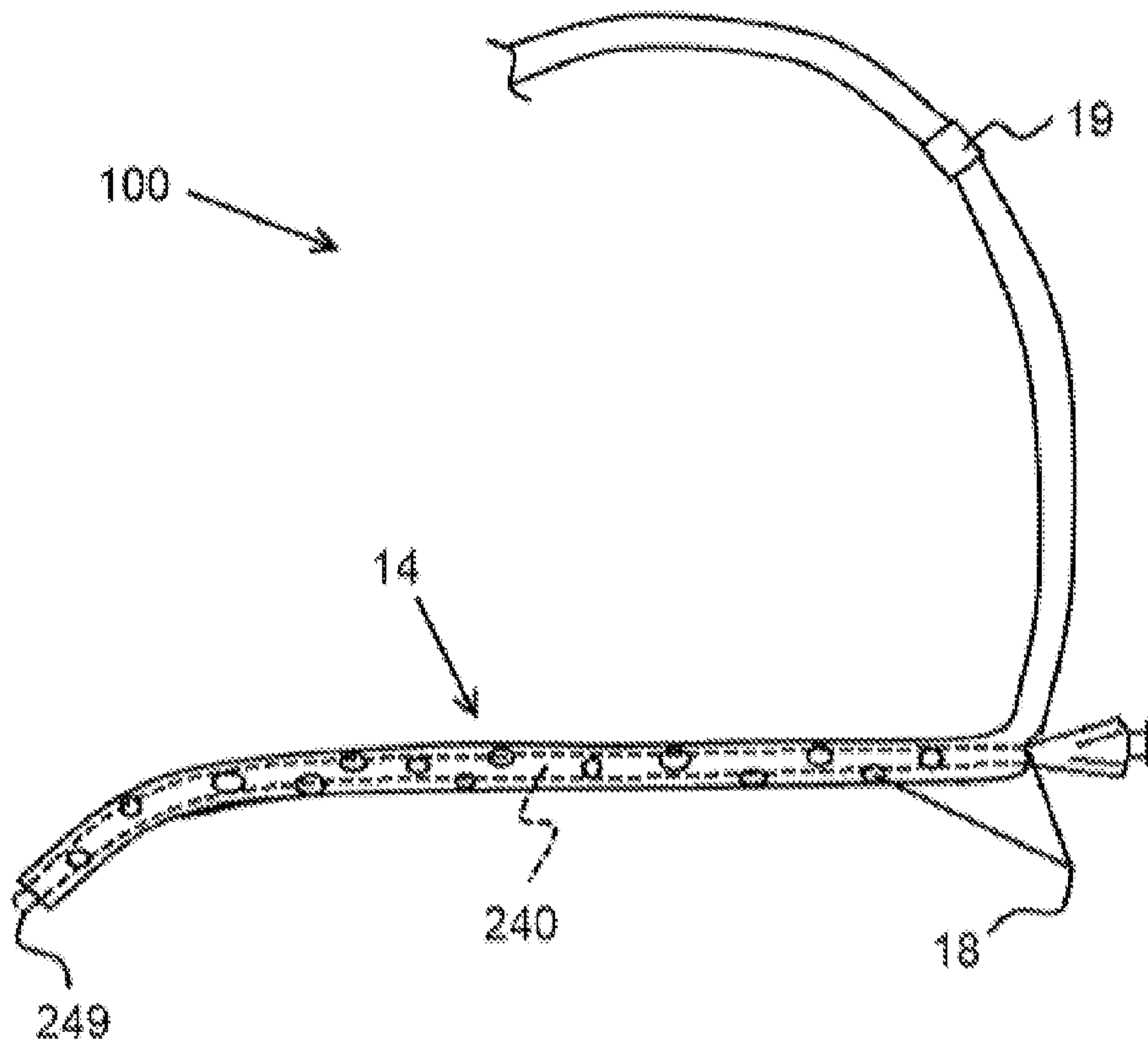

(57) **Abrégé/Abstract:**

System and components for inducing pleurodesis or other sclerosis or desired adhesion conditions to treat a patient, while minimizing likelihood of tissue damage from direct application of sclerosis-enhancing materials. A tube device is provided that is configured to elute sclerosis-enhancing material and/or other medicaments via a fenestrated drainage tube. The assembly of tube device with outer (typically drainage) tube may include one or more features configured to enhance delivery of medicament and/or drainage through the same assembly.

(12) INTERNATIONAL APPLICATION PUBLISHED UNDER THE PATENT COOPERATION TREATY (PCT)

(19) World Intellectual Property  
Organization  
International Bureau(43) International Publication Date  
2 July 2015 (02.07.2015)(10) International Publication Number  
**WO 2015/099926 A1**

- (51) International Patent Classification:  
*A61M 25/00* (2006.01) *A61M 25/06* (2006.01)
- (21) International Application Number:  
PCT/US2014/067019
- (22) International Filing Date:  
24 November 2014 (24.11.2014)
- (25) Filing Language: English
- (26) Publication Language: English
- (30) Priority Data:  
14/139,008 23 December 2013 (23.12.2013) US
- (71) Applicant: CAREFUSION 2200, INC. [US/US]; 3750 Torrey View Court, San Diego, CA 92130 (US).
- (72) Inventors: DEVRIES, Elise; 1631 West Leland Avenue, Apt. 2E, Chicago, IL 60640 (US). KRUEGER, John, A.; S79W17526 Alan Drive, Muskego, WI 53150 (US). MASSI, Shayna; 4503 North Rockwell #1, Chicago, IL 60625 (US). RAY, John; 1128 Amelia Court, Indian Creek, IL 60061 (US). DOSHI, Palak; 26W368 Glen Eagles Drive, Winfield, IL 60190 (US).
- (74) Agent: COPELAND, Trevor, K.; Brinks Hofer Gilson & Lione, P.O. Box 10087, Chicago, IL 60610 (US).
- (81) Designated States (*unless otherwise indicated, for every kind of national protection available*): AE, AG, AL, AM, AO, AT, AU, AZ, BA, BB, BG, BH, BN, BR, BW, BY, BZ, CA, CH, CL, CN, CO, CR, CU, CZ, DE, DK, DM, DO, DZ, EC, EE, EG, ES, FI, GB, GD, GE, GH, GM, GT, HN, HR, HU, ID, IL, IN, IR, IS, JP, KE, KG, KN, KP, KR, KZ, LA, LC, LK, LR, LS, LU, LY, MA, MD, ME, MG, MK, MN, MW, MX, MY, MZ, NA, NG, NI, NO, NZ, OM, PA, PE, PG, PH, PL, PT, QA, RO, RS, RU, RW, SA, SC, SD, SE, SG, SK, SL, SM, ST, SV, SY, TH, TJ, TM, TN, TR, TT, TZ, UA, UG, US, UZ, VC, VN, ZA, ZM, ZW.
- (84) Designated States (*unless otherwise indicated, for every kind of regional protection available*): ARIPO (BW, GH, GM, KE, LR, LS, MW, MZ, NA, RW, SD, SL, ST, SZ, TZ, UG, ZM, ZW), Eurasian (AM, AZ, BY, KG, KZ, RU, TJ, TM), European (AL, AT, BE, BG, CH, CY, CZ, DE,

[Continued on next page]

(54) Title: PLEURODESIS DEVICE AND METHOD

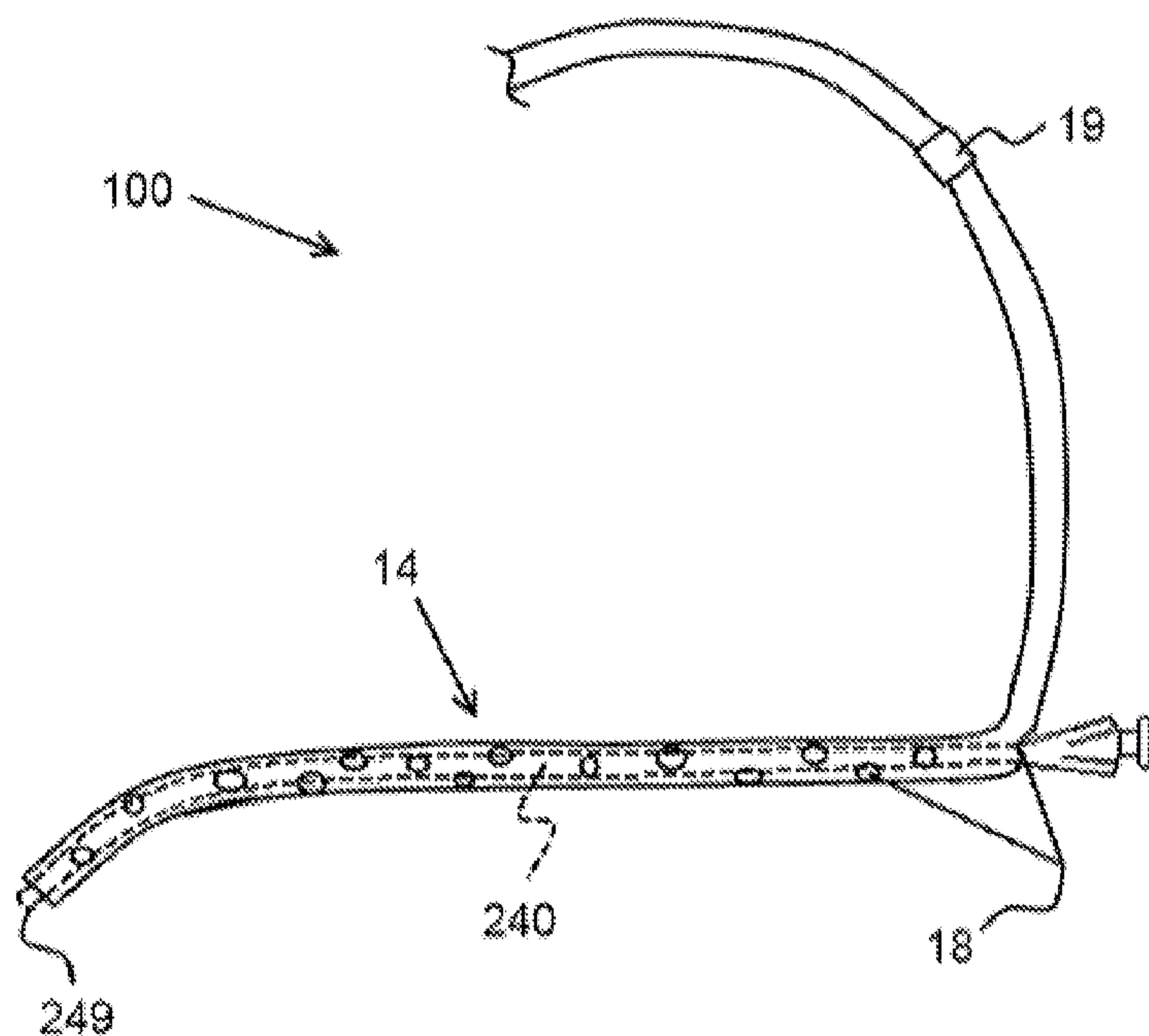
**FIG. 3**

(57) Abstract: System and components for inducing pleurodesis or other sclerosis or desired adhesion conditions to treat a patient, while minimizing likelihood of tissue damage from direct application of sclerosis-enhancing materials. A tube device is provided that is configured to elute sclerosis-enhancing material and/or other medicaments via a fenestrated drainage tube. The assembly of tube device with outer (typically drainage) tube may include one or more features configured to enhance delivery of medicament and/or drainage through the same assembly.

**WO 2015/099926 A1** 

---

DK, EE, ES, FI, FR, GB, GR, HR, HU, IE, IS, IT, LT, **Published:**  
LU, LV, MC, MK, MT, NL, NO, PL, PT, RO, RS, SE, — *with international search report (Art. 21(3))*  
SI, SK, SM, TR), OAPI (BF, BJ, CF, CG, CI, CM, GA,  
GN, GQ, GW, KM, ML, MR, NE, SN, TD, TG).

## PLEURODESIS DEVICE AND METHOD

### TECHNICAL FIELD

**[0001]** Embodiments of the present invention relate to the field of inducing pleurodesis. More particularly, embodiments of the present invention relate to methods and devices for performing a drainage function and a sclerosis- and/or adhesion-inducing function.

### BACKGROUND

**[0002]** Ascites describes an accumulation of fluid and other materials in the peritoneal or other body cavity. Pleural effusion refers to the effusion of fluid into the pleural space. Both excess fluid accumulation conditions may be treated with a drainage apparatus of the type shown in FIG. 1. The apparatus 100 is shown as installed in a patient body and includes a drainage container 114. The drainage container 114 is removably attached by a proximal tube 110 at a valve 60 to a distal catheter 12. The valve 60 may be configured in any number of ways known in the art for attaching catheters together in a fluid-tight manner, (which may include a two-part valve), and the proximal portion attached to the distal catheter 12 may be configured to be self-sealing when disconnected from the proximal tube 110. The proximal end portion of the distal catheter 12 is shown indwelling the patient, disposed through the body wall 21 into an intra-body space 23, which may be – for example – a pleural, peritoneal, or other body lumen. That proximal portion includes a sealing cuff 19 and a flexible fluid-intake length 14 including fenestrations 18, shown in the intra-body space 23. This structure may be better understood with reference to U.S. Pat. No. 5,484,401, and with reference to commercial products marketed under the name PleurX® by CareFusion® of San Diego, Calif.

**[0003]** The pleural space normally contains approximately 5 to 20 ml of fluid. The pH, glucose and electrolytes of the fluid are equilibrated with

plasma, but the fluid is relatively protein-free. The fluid is the result of the hydrostatic-oncotic pressure of the capillaries of the parietal pleura. About 80-90% of the fluid is reabsorbed by the pulmonary venous capillaries of the visceral pleura, and the remaining 10-20% is reabsorbed by the pleural lymphatic system. The turnover of fluid in the pleural space is normally quite rapid—roughly 35 to 75% per hour, so that 5 to 10 liters of fluid move through the pleural space each day.

**[0004]** A disruption in the balance between the movement of fluid into the pleural space and the movement of fluid out of the pleural space may produce excessive fluid accumulation in the pleural space. Such disruptions may include, for example, (1) increased capillary permeability resulting from inflammatory processes such as pneumonia, (2) increased hydrostatic pressure as in congestive heart failure, (3) increased negative intrapleural pressure as seen in atelectasis (partial or total lung collapse), (4) decreased oncotic pressure as occurs in the nephrotic syndrome with hypoalbuminemia, and (5) increased oncotic pressure of pleural fluid as occurs in the inflammation of pleural tumor growth or infection. Pleural effusion is particularly common in patients with disseminated breast cancer, lung cancer or lymphatic cancer and patients with congestive heart failure, but also occurs in patients with nearly all other forms of malignancy.

**[0005]** The clinical manifestations of pleural effusion include dyspnea, cough and chest pain which diminish the patient's quality of life. Although pleural effusion typically occurs toward the end of terminal malignancies such as breast cancer, it occurs earlier in other diseases. Therefore relieving the clinical manifestations of pleural effusion is of a real and extended advantage to the patient. For example, non-breast cancer patients with pleural effusion have been known to survive for years.

**[0006]** There are a number of treatments for pleural effusion. If the patient is asymptomatic and the effusion is known to be malignant or paramalignant, treatment may not be required. Such patients may develop

progressive pleural effusions that eventually do produce symptoms requiring treatment, but some will reach a stage where the effusions and reabsorption reach an equilibrium that is still asymptomatic and does not necessitate treatment.

**[0007]** Pleurectomy and pleural abrasion is generally effective in obliterating the pleural space and, thus, controlling the malignant pleural effusion. This procedure is done in many patients who undergo thoracotomy for an undiagnosed pleural effusion and are found to have malignancy, since this would prevent the subsequent development of a symptomatic pleural effusion. However, pleurectomy is a major surgical procedure associated with substantial morbidity and some mortality. Therefore, this procedure is usually reserved for patients with an expected survival of at least several months, who are in relative good condition, who have a trapped lung, or who have failed a sclerosing agent procedure.

**[0008]** In general, systemic chemotherapy is disappointing for the control of malignant pleural effusions. However, patients with lymphoma, breast cancer, or small cell carcinoma of the lung may obtain an excellent response to chemotherapy. Another approach to removing fluid from the pleural space has been to surgically implant a chest tube. Such tubes are commonly quite rigid and fairly large in diameter and are implanted by making a surgical incision and spreading apart adjacent ribs to fit the tube into place. Such procedures are painful to the patient, both initially when the chest tube is inserted and during the time it remains within the pleural space.

**[0009]** Thoracentesis is a common approach to removing pleural fluid, in which a needled catheter is introduced into the pleural space through an incision in the chest cavity and fluid is positively drawn out through the catheter using a syringe or a vacuum source. The procedure may also include aspiration utilizing a separate syringe. There are a number of difficulties in thoracentesis, including the risk of puncturing a lung with the catheter tip or with the needle used to introduce the catheter, the risk of

collapsing a lung by relieving the negative pressure in the pleural space, the possibility of aggravating the pleural effusion by stimulating fluid production in the introduction of the catheter, and the risk of infection. One of the primary difficulties with ordinary thoracentesis procedures is that fluid reaccumulates in the pleural space relatively quickly after the procedure is performed, and so it is necessary to perform the procedure repeatedly—as often as every few days. Similar techniques and difficulties exist for certain abdominal/ peritoneal conditions. However, it would be advantageous to provide improved methods for treating pleural effusions, peritoneal ascites, and other conditions.

#### BRIEF SUMMARY

**[0010]** In one aspect, embodiments may include embodiments of methods for introducing a sclerotic agent through a thoracic drainage catheter, a rigid needle, a flexible (including memory-metal) cannula, or other device providing access to a target site in need of treatment. In another aspect, embodiments may provide methods for effecting pleurodesis in an outpatient procedure that may be effected via an indwelling drainage catheter.

**[0010a]** In accordance with another aspect of the present invention, there is provided an injection catheter assembly comprising: an elongate flexible outer tube body including: a distal length configured to indwell a patient body trunk cavity; and at least one body lumen extending longitudinally through at least a lengthwise portion of the distal length, the body lumen substantially defined by an inner diameter surface of the outer tube body; wherein at least one portion of the distal length is configured as an injection portion that includes at least one outer tube body surface with at least one fenestration, the at least one fenestration including a first fenestration at a location distal of a sealing cuff on the outer tube body surface, the outer tube body surface constructed to permit passage therethrough of a sclerotic agent; and a flexible, curved inner cannula body

dimensioned for passage through the body lumen of the outer tube body, the inner cannula body being fully removably insertable through the first fenestration into the body lumen of the outer tube body, the inner cannula body including: a memory-material portion imposing a pre-determined curve along a length of the inner cannula body; an injection lumen extending longitudinally through at least a lengthwise portion of the inner cannula body; at least one distal-region opening configured for dispensing a medicament; a first state where the distal-region opening of the inner cannula body is outside of the outer tube body; and a second state wherein the inner cannula body is disposed through the first fenestration at the location distal of the sealing cuff, into the body lumen, and through at least a lengthwise portion of the distal outer tube body length, so that: the distal region opening of the inner cannula body is within the outer tube body and is in fluid communication with the body lumen of the outer tube body, or a sufficient length of the inner cannula body extends distally from the first fenestration through the injection portion of the outer tube body such that the distal-region opening of the inner cannula body is disposed outside of the outer tube body.

#### BRIEF DESCRIPTION OF THE DRAWINGS

**[0011]** FIGS. 1 illustrates a drainage apparatus as known in the prior art;

**[0012]** FIG. 2 shows an assembly view of a device including an outer tube configured as a drain tube and a memory-curved inner tube;

**[0013]** FIG. 2A shows a transverse section view of the inner tube along line 2A-2A of FIG. 2;

**[0014]** FIGS. 2B-2D show different distal end tip configurations of the inner tube;

**[0015]** FIG. 3 shows an assembled view of the device of FIG. 2;

**[0016]** FIGS. 4-4C show a method of dispensing a medicament;

**[0017]** FIG. 5 shows a device and method for autologous or other blood infusion; and

**[0018]** FIG. 6 shows a split-catheter embodiment for infusion and drainage.

#### DETAILED DESCRIPTION

**[0019]** Embodiments generally are described with reference to the drawings in which like elements are generally referred to by like numerals. The relationship and functioning of the various elements of the embodiments may better be understood by reference to the following detailed description. However, embodiments are not limited to those illustrated in the drawings. It should be understood that the drawings are not necessarily to scale, and in certain instances details may have been omitted that are not necessary for an understanding of embodiments of the present invention, such as—for example—conventional fabrication and assembly.

**[0020]** The present invention now will be described more fully hereinafter. This invention may, however, be embodied in many different forms and should not be construed as limited to the embodiments set forth herein; rather, these embodiments are provided so that this disclosure will be thorough and complete, and will fully convey the scope of the invention to those skilled in the art. As used in this specification and the claims, the singular forms “a,” “an,” and “the” include plural referents unless the context clearly indicates otherwise. Throughout the specification, the terms “distal” and “distally” shall denote a position, direction, or orientation that is generally away from the physician and/or toward the patient. Accordingly, the terms “proximal” and “proximally” shall denote a position, direction, or orientation that is generally towards the physician and/or away from the patient.

**[0021]** Within a device for accelerating and/or enhancing pleurodesis, it may be desirable to provide a distal indwelling portion of the tube that is

coated at least partially with a substance that is intended to be delivered to the body over an extended period of time in a diluted, consistent, and/or titrated manner. One example of such a system maybe a tube body configured for pleurodesis of the pleural space by means of a sclerosing agent such as, for example, silver nitrate. In these instances, it is preferable that the silver nitrate coating in its base/concentrated form not contact the surrounding tissue directly due to its high concentration and potential tissue reactions thereto. The coating most preferably will be eluted or otherwise be released over time from the catheter. Other suitable sclerotic agents may include antimicrobial agents, or other materials configured for inducing pleurodesis (e.g., polyvinylpyrrolidone (PVP), talc (e.g., as a slurry), bleomycin, mitoxantrone, mitomycin, thiotpea, cytarabine, quinacrine, tetracycline (defined herein to include tetracycline derivative such as doxycycline and minocycline), OK432 (*Streptococcus pyogenes* type A3), SSAg (*Staphylococcus aureus* superantigen), fibrin glue, povidone iodine (PVP-I), autologous "blood patch," or any combination thereof).

**[0022]** Modern pleural and peritoneal drainage systems have made it possible for patients to use devices like those illustrated in FIG. 1 to conduct drainage on periodic office or hospital visits. For patients who experience recurrent effusions, repeat drainage procedures at a clinical facility can be avoided by the installation of an indwelling tunneled catheter that can be drained at home. In addition, for some patients it may be desirable to administer a substance or provide a therapeutic intervention to the area where the catheter is inserted. For example, in patients with pleural effusion who have a lung that re-expands upon drainage, fusion of the visceral and parietal pleura is a treatment option that eliminates at least a portion of the pleural cavity and thus eliminates the space where the fluid accumulates. This procedure is called pleurodesis and can be accomplished through draining the effusion and inciting the patient's foreign body response. Mechanical or chemical means can be used to

cause the irritation. In other instances, continuous delivery of medication or cell signaling molecules may be desired in the area where the catheter resides.

**[0023]** Chemical pleurodesis may use irritants and/or antibiotic materials (also known as sclerotic/ sclerosis agents) that may also provide mechanical irritation to trigger cell growth and/or resist infection. Examples of materials known and used include bleomycin, tetracycline, and povidone iodine. As another example, a slurry of talc can be introduced into the pleural space. The instilled chemicals cause irritation between the parietal and the visceral layers of the pleura which closes off the space between them and prevents further fluid from accumulating. Chemical pleurodesis may be a painful procedure, so patients are often premedicated with a sedative and analgesics. A local anesthetic may be instilled into the pleural space, or an epidural catheter may be placed for anesthesia. Generally, to be effective, introduction of structures and materials for pleurodesis desirable will create irritation and then keep the space dry. In order to establish pleurodesis, it is preferable that the parietal and visceral layers of the pleura remain in juxtaposition. As such, it is preferable that when mechanical and/or chemical irritation is complete a drainage tube will remain in place to remove the fluid over the time it takes for the adhesion accomplishing pleurodesis to occur. Certain structures and methods for delivering sclerosis agents are disclosed in U.S. App. Pub.

No. 2013/0102999 to Looper, et al.

**[0024]** Chemical pleurodesis generally is currently performed in one of two ways: 1) The sclerotic pleurodesis agent is introduced through a chest tube into the pleural space, or 2) The agent is introduced during a video assisted thoracoscopy (VATS) procedure while the patient is under general anesthesia. Because both methods require use of a chest tube, the patient is required to stay in the hospital for up to one week until the effusion resolves. At present, no outpatient procedures or indwelling

catheters are known to be used in the instillation of sclerosing agents. As such, it would be useful to provide methods for effecting pleurodesis on a less-invasive basis, including in an outpatient procedure that may be effected via an indwelling drainage catheter.

**[0025]** Main components of an injection catheter assembly 200 and methods for facilitating pleurodesis, or another sclerosis-inducement procedure, are described with reference to FIGS. 2-4C. FIG. 2 shows a disassembled view, including an elongate flexible outer tube body 212 including a distal length 214 configured to indwell a patient body trunk cavity. The outer tube body 212 includes at least one body lumen extending longitudinally through at least a lengthwise portion of the distal length, where the lumen substantially defined by an inner diameter surface of the tube body (internal lumen not shown, and may include a plurality of lumens as multi-lumen tube construction is well-characterized in the art). The outer tube body 212 shown is generally configured as a drainage tube with fenestrations 218, which are configured to facilitate drainage from a body cavity.

**[0026]** The assembly 200 includes a flexible, curved inner cannula body 240, which is dimensioned for passage through the body lumen of the outer tube body 212. The inner cannula body 240 includes a memory-material 242 imposing a pre-determined curve along a length 249 of the inner cannula body 240. The inner cannula body 240 also includes an injection lumen 244 and at least one distal-region opening 246 configured for dispensing a medicament. The memory-material 242 and the injection lumen 244 are shown more clearly in FIG. 2A, which provides a magnified transverse section view along line 2A-2A of FIG. 2. The inner and/or outer surfaces of the inner cannula body 240 and the outer tube body 212 may include a lubricious coating configured to resist adhesion by a medicament. Memory material may include any appropriate metallic or polymeric material upon which shape-memory may be imposed, while allowing flexibility. For example, various nitinol and other memory metal

compounds are well-known and commonly used in the medical device art. Other materials are known in the art that can receive and default-return to a shape (imposed by mechanical, temperature, and/or other means) after flexure into different shape(s). The memory configuration may be assumed based upon temperature, release of constraint, and/or by active means, as known in the art for different materials.

**[0027]** Medicaments dispensable through the assembly 200 may include sclerosis-inducing agent(s), therapeutic agent(s), chemotherapy agent(s), gene therapy agent(s), and/or other materials, introduced by syringe, infusion pump, or other means. The medicaments may be configured as liquids, solutions, suspensions, gels, pastes, or any combination thereof and may include effervescent material (e.g., sodium bicarbonate and citric acid or other combination that can be activated by temperature, liquid-contact, or other means) configured to aid dispersion through the body cavity by formation of bubbles and/or spreading by similar means. Examples of medicaments may include talc, silver nitrate, bleomycin, and/or other sclerosis-inducing agents. In addition or in the alternative, examples of medicaments may include chemotherapy agents, antibiotic(s), loculation-breakup compound(s) (e.g., tissue plasminogen activator tPA), and/or other materials, which may be introduced after the assembly is placed in a patient body, or which may be pre-loaded into the injection lumen 244 before the inner cannula is fully engaged into the outer tube 212. Each medicament or combination of medicaments may be provided as, or include additives to be rendered, radiopaque to enhance visibility with medical imaging means.

**[0028]** A removable structure such as, for example, a stylet (not shown) may be used to block and/or seal the injection lumen of the inner cannula 240. The inner cannula body 240 may include one or more one visualization markers configured to be visualizable in a patient body by at least one of fluoroscopy, ultrasound, magnetic resonance imaging, and

computed tomography. This feature may assist treating personnel during a procedure for introducing a medicament through the inner cannula 240.

**[0029]** FIGS. 2B, 2C, and 2D show tip configurations that may provide for desirable dispensing patterns for directing a selected medicament.

FIG. 2B shows an end-on view of an open tip 249a of an inner cannula, which opening is configured to emit a stream or otherwise generally unimpeded flow of medicament.

FIG. 2C shows an end-on view of a segmented-opening tip 249b of an inner cannula, which opening is configured to emit a plurality of streams or coarse spray of medicament.

FIG. 2D shows an end-on view of a multi-aperture tip 249c of an inner cannula, which opening is configured to emit a spray of medicament.

**[0030]** FIG. 3 shows an inner cannula 240 assembled to a drainage apparatus 100. In this embodiment, the inner cannula 240 is shown as having been inserted through one of the fenestrations 18. In the illustrated embodiment, the fenestration 18 is the one nearest the cuff 19. In certain embodiments, a hub, port, or other structure may be provided on a drainage apparatus 100 (e.g., a Touhy-Borst valve or other construct, not shown) for effective access by an inner cannula 240. The distal end 249 of the inner cannula 240 extends beyond the distal end 17 of the distal length 14 of the drainage apparatus 100, and may extend through a valve (e.g., like valve 60 of FIG. 1).

**[0031]** FIGS. 4A-4C show, in simplified/ diagrammatic form, a method of use for an inner cannula 240. The inner cannula 240 may be assembled to a drainage apparatus 100 as shown in FIG. 3, and/or it may be directed through a valved introducer 190. The distal tip 249 of the inner cannula 240 is directed to adjacent a target region 471 (e.g., a location in the pleural space). In the illustrations, a drainage catheter 412 is shown as having been directed through the valved introducer 190. Then, as shown in FIG. 4A, a medicament (such as – for example – a talc-containing material) 477 is directed onto a surface of the target region 471. The material 477 may be distributed in a continuous manner or pattern, or in a

staggered discontinuous manner or pattern, and shown in FIGS. 4B, where the inner cannula 240 has been retracted along its axis and/or otherwise manipulated during dispensing of the material 477. The material 477 may be directed from and through any appropriate injection system, such as – for example – a syringe, a pressurized injector, or any other appropriate means for injection, as will be apparent to those skilled in the art.

**[0032]** In preferred embodiments, the pattern or other distribution of material 477 may be performed in a manner to promote desired adhesion by location of placement. As known in the art, the material 477 will generally generate a bodily response to mechanical and/or chemical irritation that promotes adhesion. The adhesion is desirable to decrease or eliminate an undesired space (e.g., pleural effusion). This method may also be effected with any apparatus described below with reference to FIGS. 5 and 6.

**[0033]** A patient's own blood (or compatible blood or blood components) may be effective to provide or enhance therapeutic treatment of a pleural effusion or other condition being treated with a method and/or apparatus of the present disclosure, and may therefore be considered as a medicament in the present disclosure. In another embodiment, described here with reference to FIG. 5, a method and apparatus may be provided for autologous blood transfer to the target region. A catheter 512 configured to partially indwell a patient in the manner of catheters 12 described above is provided with a valve 560 connecting the catheter 512 in fluid communication with tubing 587. An opposite end of the tubing 587 may be placed in fluid communication with an autologous or other blood supply 589 (shown diagrammatically only; e.g., a patient's own vein via an intravenous needle, a container of autologous or otherwise compatible whole blood or blood components). A shunt or pump 588 may be provided to facilitate blood flow to and through the tubing 587, valve 560, and catheter 512. The interior surface(s) of the tubing 587, shunt or pump 588 (if present), valve 560, and/or catheter 512 may be coated with a lubricious

material and/or an anti-clotting agent (e.g., heparin) to lessen/minimize the possibility of the blood clotting or adhering to those surfaces. The tubing 587 may be removed and replaced with a vacuum bottle or other drainage modality (not shown) when desired to effect drainage of the region indwelt by the catheter 512.

**[0034]** A different apparatus embodiment for effecting the method described with reference to FIG. 5 is shown in FIG. 6. A catheter 612 configured to partially indwell a patient in the manner of catheters 12 described above is provided, including a Y-type split region 612a that provides a plurality of tube lumens along a length of the device. A first branch 612b is provided with a valve 660 configured to interface with a vacuum bottle or other drainage modality 6114 (e.g., via a drainage tube, not shown, like the tube 110 described above). The other branch 612c may include a dripless valve 661 configured to interface with an infusion assembly 685 (shown only diagrammatically) which may include a syringe, infusion pump, autologous blood supply, or other means for supplying a medicament or other desired material for infusion via the catheter 612. The infusion assembly 685 may be placed in communication with the drainage modality 6114 in a manner providing for coordinated infusion and drainage via the catheter 660. The communication may be electrical, mechanical, fluid/vacuum-based, or via any other means appropriate for effecting desired coordination of infusion and drainage.

**[0035]** Those of skill in the art will appreciate that embodiments not expressly illustrated herein may be practiced within the scope of the present invention, including that features described herein for different embodiments may be combined with each other and/or with currently-known or future-developed technologies while remaining within the scope of the claims presented here. For example, the various physical structures disclosed may also provide mechanical irritation promoting a desired sclerotic effect, and the structures and components disclosed herein may be combined with each other or other features. Although specific terms

are employed herein, they are used in a generic and descriptive sense only and not for purposes of limitation. It is therefore intended that the foregoing detailed description be regarded as illustrative rather than limiting. And, it should be understood that the following claims, including all equivalents, are intended to define the spirit and scope of this invention. Furthermore, the advantages described above are not necessarily the only advantages of the invention, and it is not necessarily expected that all of the described advantages will be achieved with every embodiment of the invention.

We claim:

1. An injection catheter assembly comprising:
  - an elongate flexible outer tube body including:
    - a distal length configured to indwell a patient body trunk cavity; and
    - at least one body lumen extending longitudinally through at least a lengthwise portion of the distal length, the body lumen substantially defined by an inner diameter surface of the outer tube body;
      - wherein at least one portion of the distal length is configured as an injection portion that includes at least one outer tube body surface with at least one fenestration, the at least one fenestration including a first fenestration at a location distal of a sealing cuff on the outer tube body surface, the outer tube body surface constructed to permit passage therethrough of a sclerotic agent; and
      - a flexible, curved inner cannula body dimensioned for passage through the body lumen of the outer tube body, the inner cannula body being fully removably insertable through the first fenestration into the body lumen of the outer tube body, the inner cannula body including:
        - a memory-material portion imposing a pre-determined curve along a length of the inner cannula body;
        - an injection lumen extending longitudinally through at least a lengthwise portion of the inner cannula body;
        - at least one distal-region opening configured for dispensing a medicament;
          - a first state where the distal-region opening of the inner cannula body is outside of the outer tube body; and
          - a second state wherein the inner cannula body is disposed through the first fenestration at the location distal of the sealing cuff, into the body lumen,

and through at least a lengthwise portion of the distal outer tube body length, so that:

the distal region opening of the inner cannula body is within the outer tube body and is in fluid communication with the body lumen of the outer tube body, or

a sufficient length of the inner cannula body extends distally from the first fenestration through the injection portion of the outer tube body such that the distal-region opening of the inner cannula body is disposed outside of the outer tube body.

2. The assembly of claim 1, further comprising a port in fluid communication with the injection lumen.
3. The assembly of claim 1 or 2, wherein the at least one fenestration is dimensioned to permit effective passage there through of a talc suspension.
4. The assembly of any one of claims 1 to 3, wherein the at least one body lumen of the outer tube body comprises a plurality of lumens.
5. The assembly of any one of claims 1 to 4, the inner cannula body further comprising at least one visualization marker configured to be visualizable in a patient body by at least one of fluoroscopy, ultrasound, magnetic resonance imaging, and computed tomography.
6. The assembly of any one of claims 1 to 5, wherein the injection lumen of the inner cannula body is at least partially pre-filled with dispensable medicament.

7. The assembly of claim 6, wherein the dispensable medicament comprises a sclerosing agent.
8. The assembly of claim 6, wherein the dispensable medicament comprises a therapeutic agent.
9. The assembly of claim 6, wherein the dispensable medicament comprises an effervescent material.
10. The assembly of any one of claims 1 to 9, where at least one of the inner cannula body and the outer tube body comprises a lubricious coating configured to resist adhesion by a medicament.
11. The assembly of any one of claims 1 to 10, the inner cannula body further comprising a removable structure blocking fluid communication with a proximal opening of the injection lumen.
12. The assembly of any one of claims 1 to 11, wherein the first fenestration is configured to facilitate drainage from a body cavity when the inner cannula body is removed from the first fenestration.
13. Use of the assembly of any one of claims 1 to 12 for delivering medicament via catheter in a body lumen, wherein a distal portion of the assembly is for directing into a body lumen, the at least one distal-region opening for later direction to a target site in the body lumen; and wherein a medicament is for dispensing to the target site.
14. The use of claim 13, wherein the injection lumen of the inner cannula

body is at least partially pre-filled with dispensable medicament.

15. The use of claim 13, wherein the dispensable medicament comprises a sclerosing agent.

16. The use of claim 13, wherein the dispensable medicament comprises a therapeutic agent.

17. The use of claim 13, wherein the dispensable medicament comprises an effervescent material.

18. The use of claim 13, where at least one of the inner cannula body and the outer tube body includes a lubricious coating configured to resist adhesion by a medicament.

19. The use of claim 13, the inner cannula body further comprising a removable structure blocking fluid communication with a proximal opening of the injection lumen.

20. The use of claim 13, wherein the inner cannula body is disposed through at least a lengthwise portion of the distal outer tube body length during the for directing step, and is extended to or beyond a distal end of the distal outer tube body length during the later for directing step.

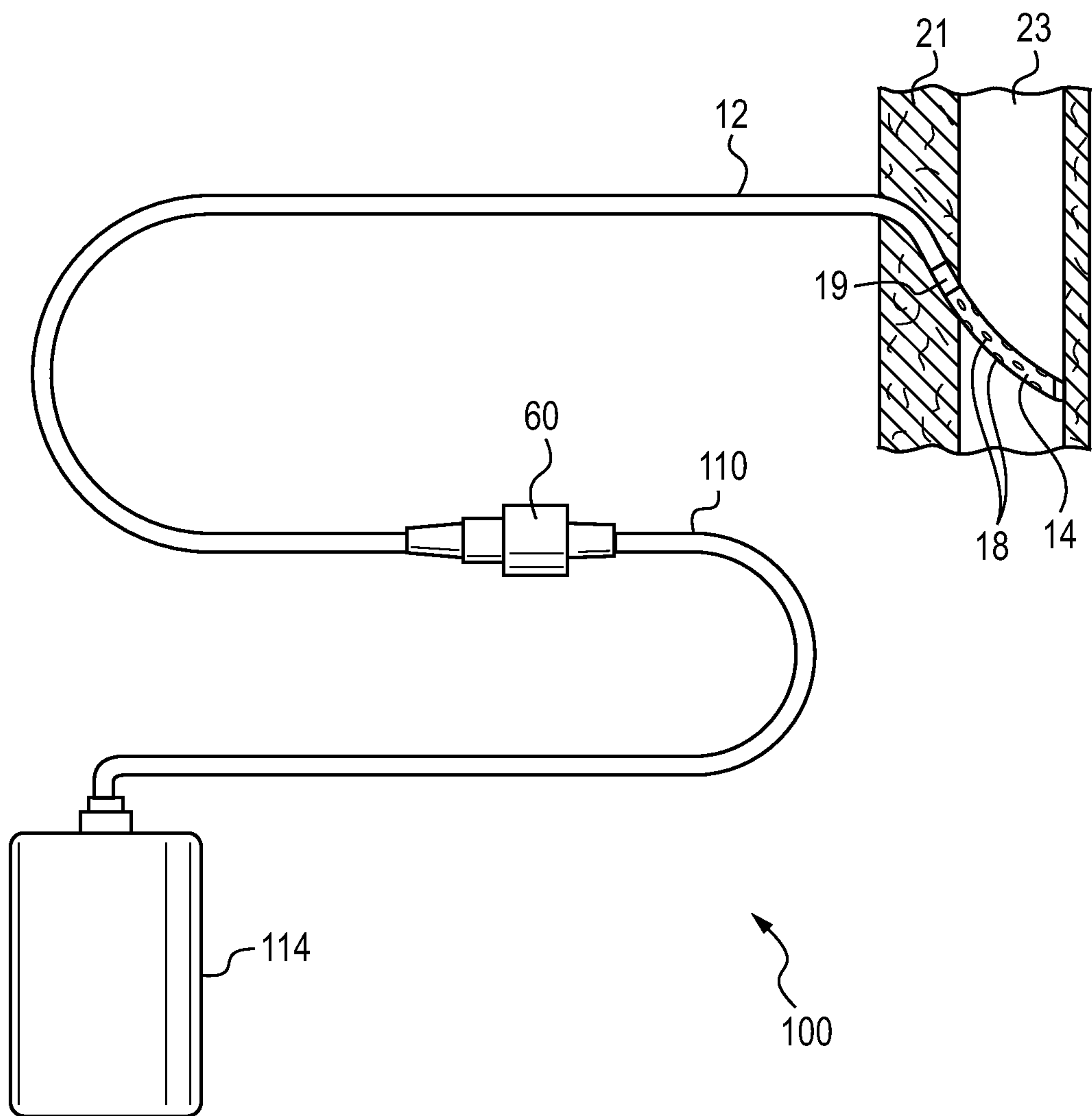

**FIG. 1**  
**PRIOR ART**

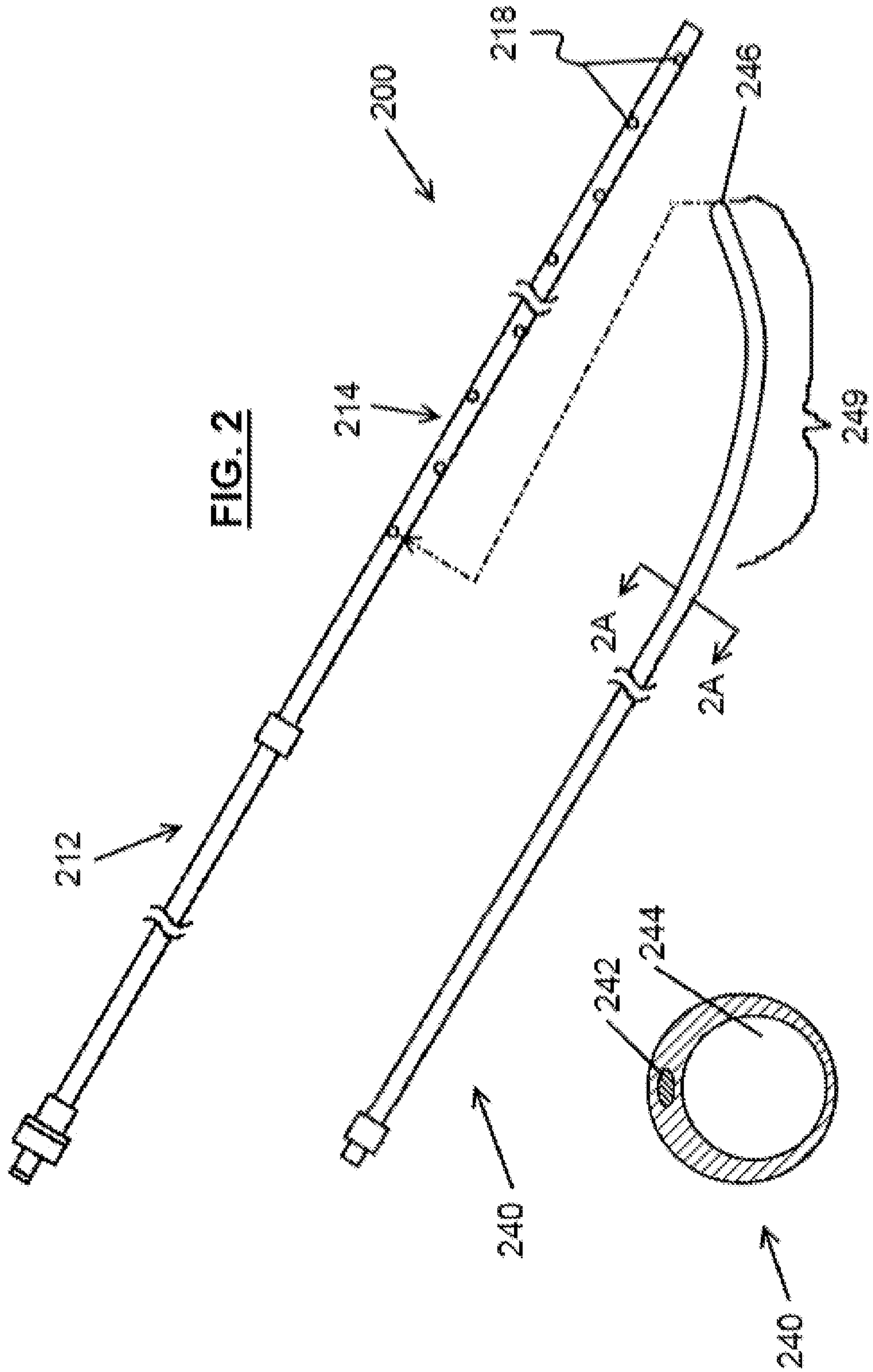

**FIG. 2**

**FIG. 2A**

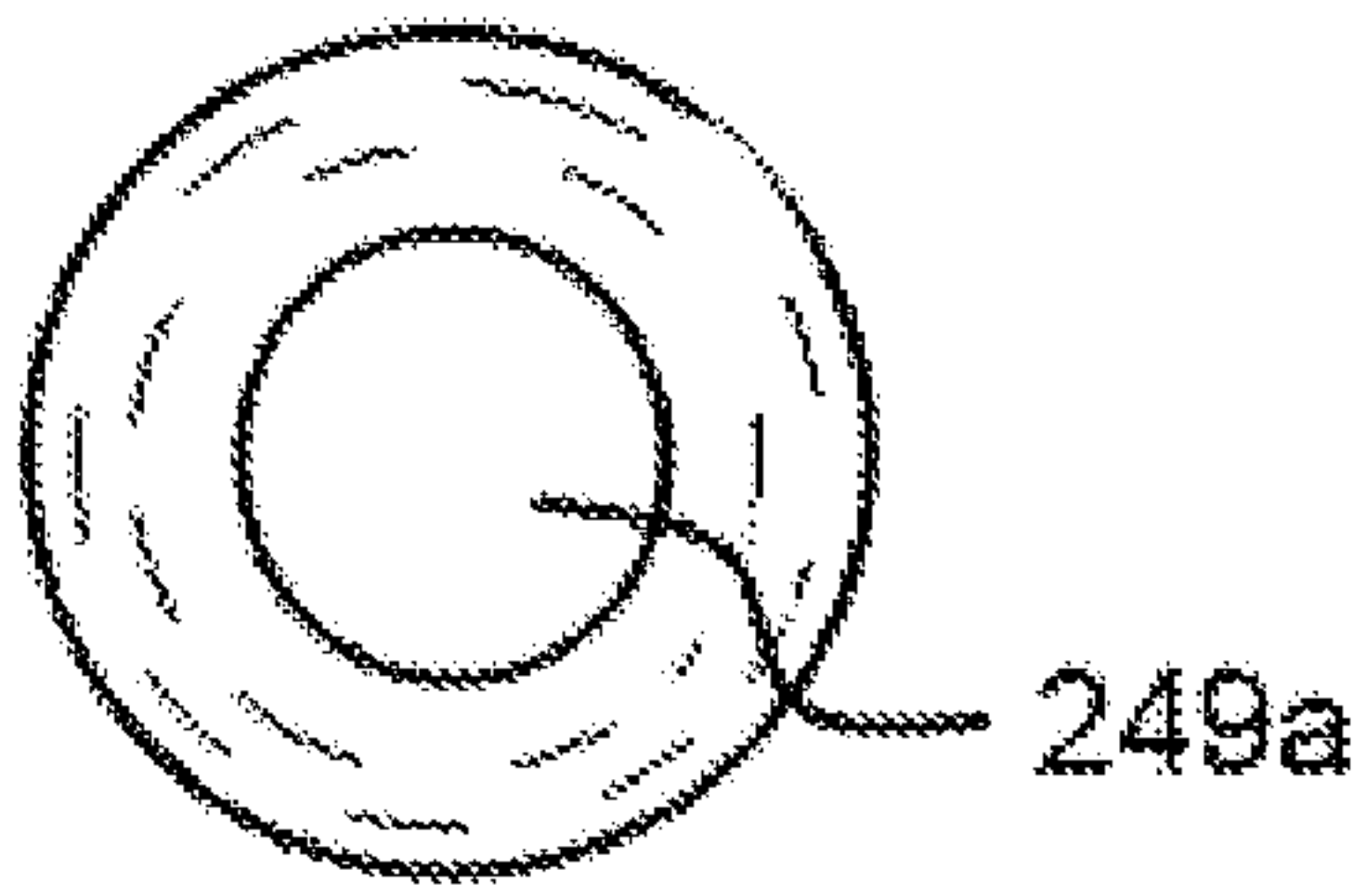

FIG. 2B

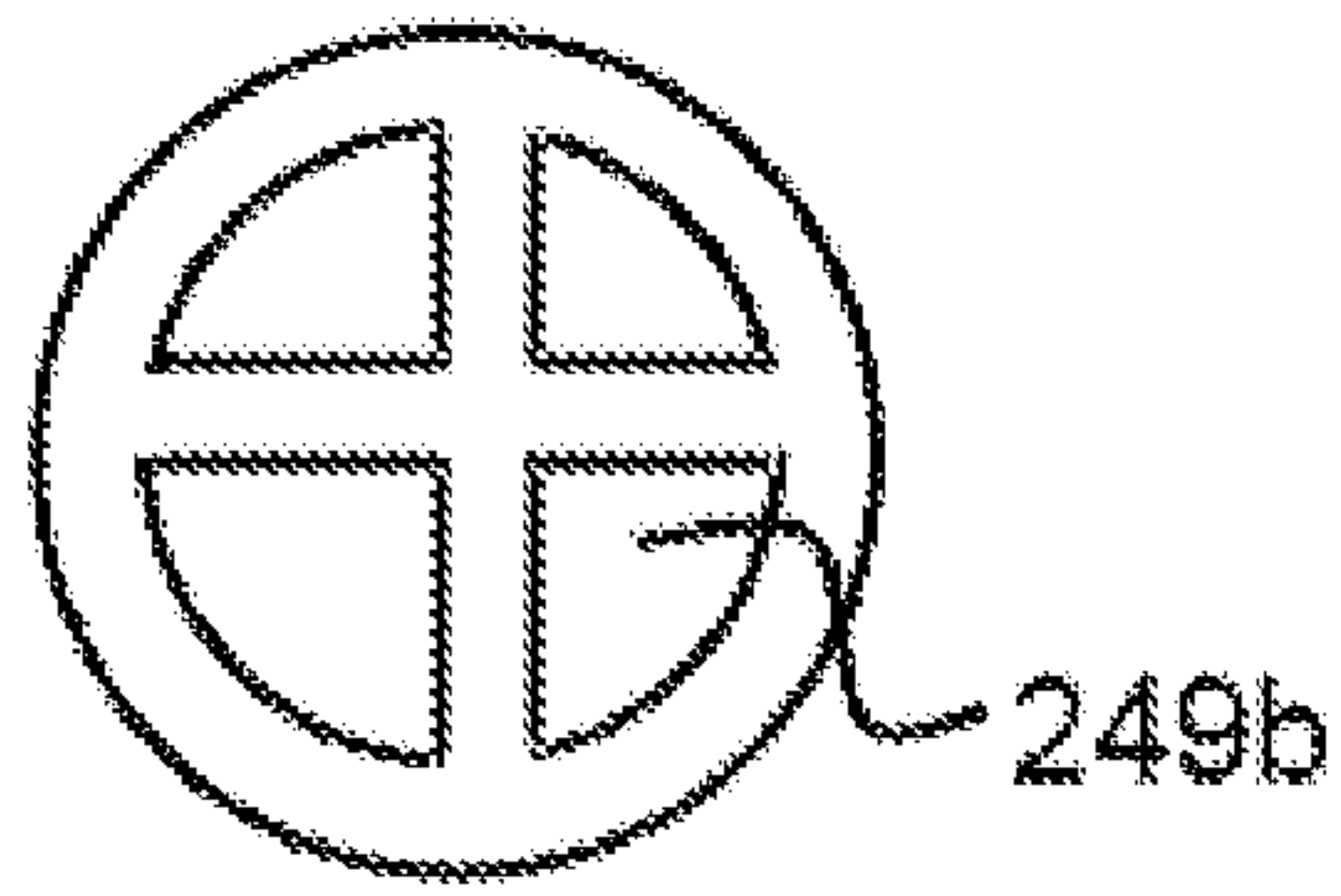

FIG. 2C

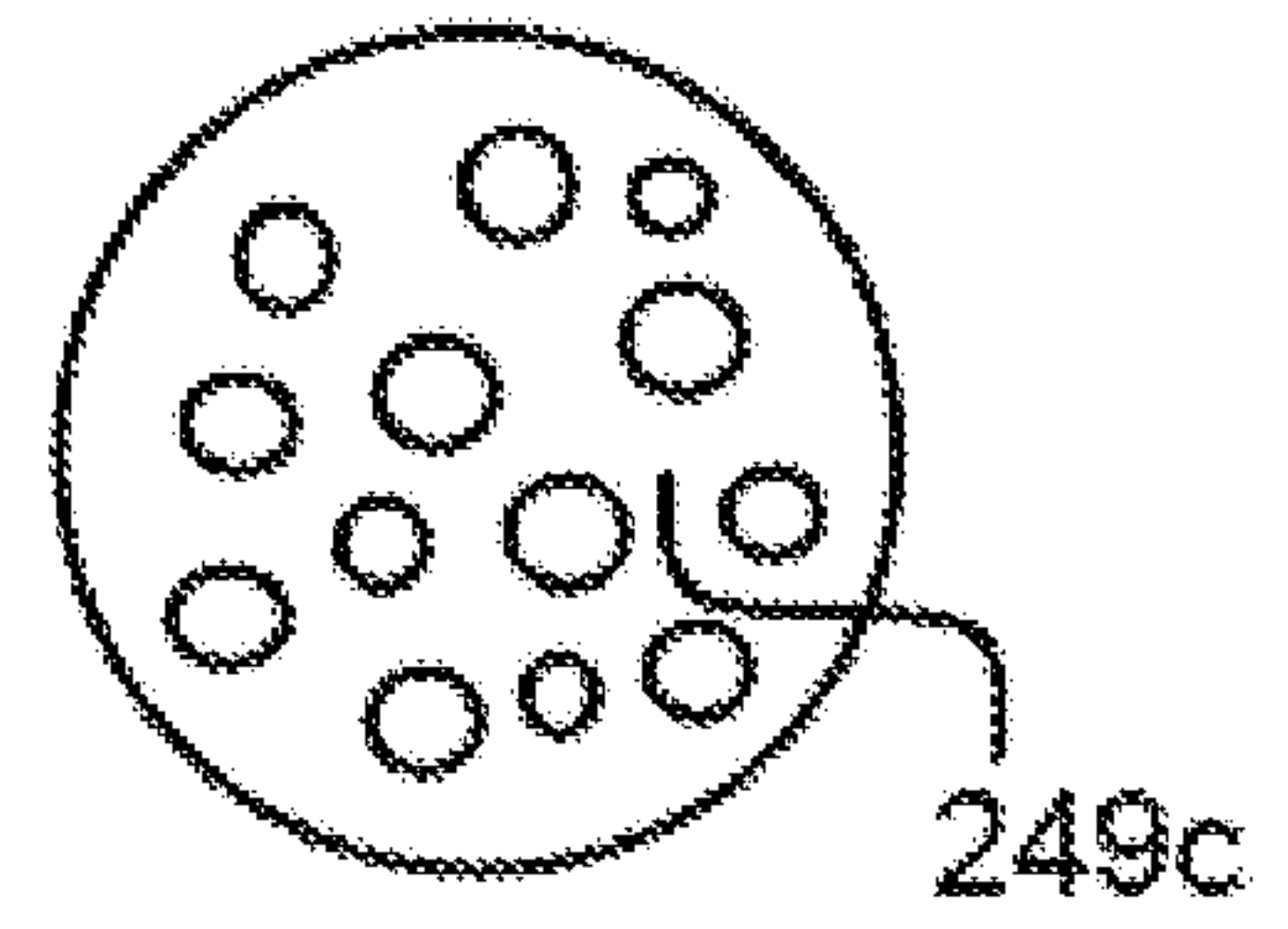

FIG. 2D

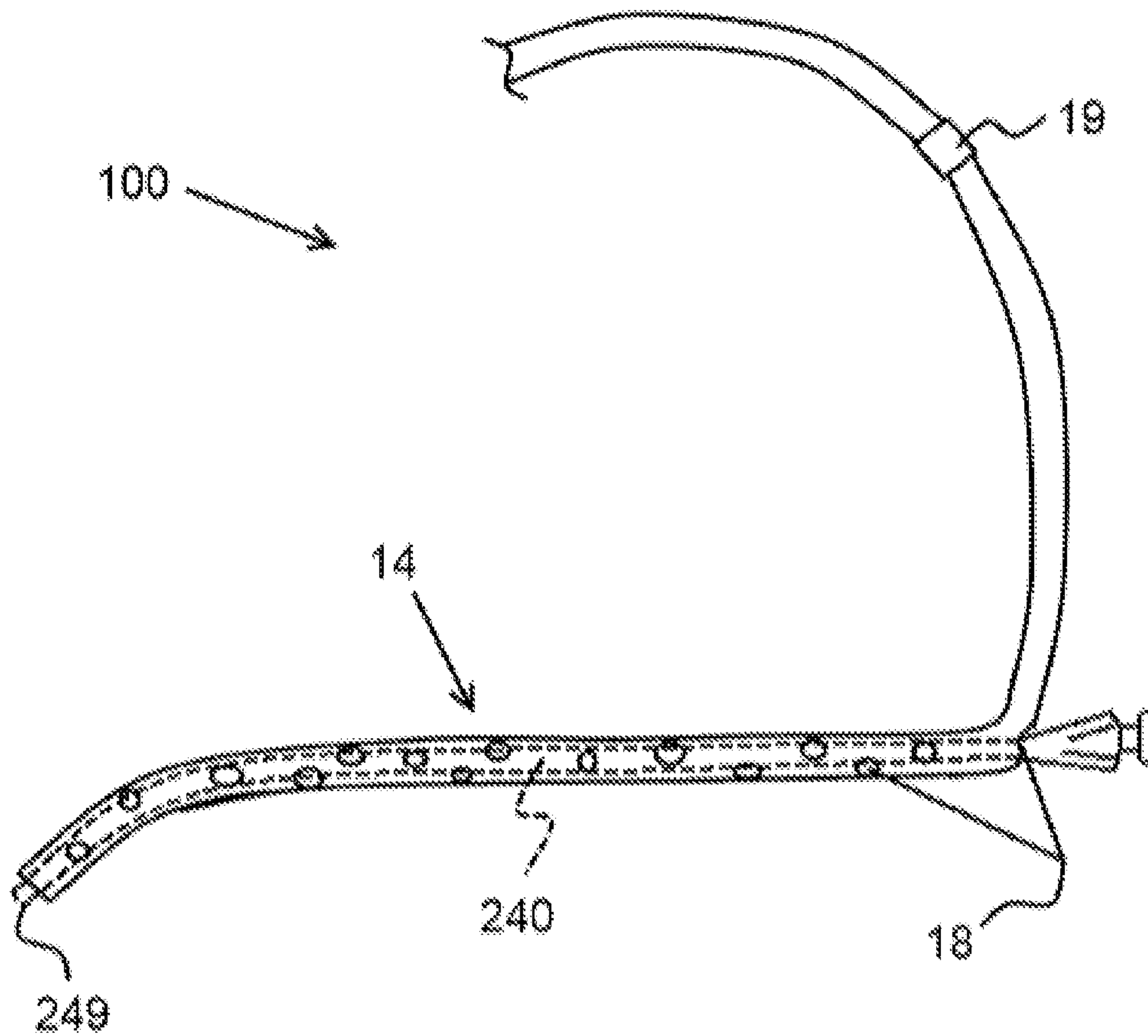

FIG. 3

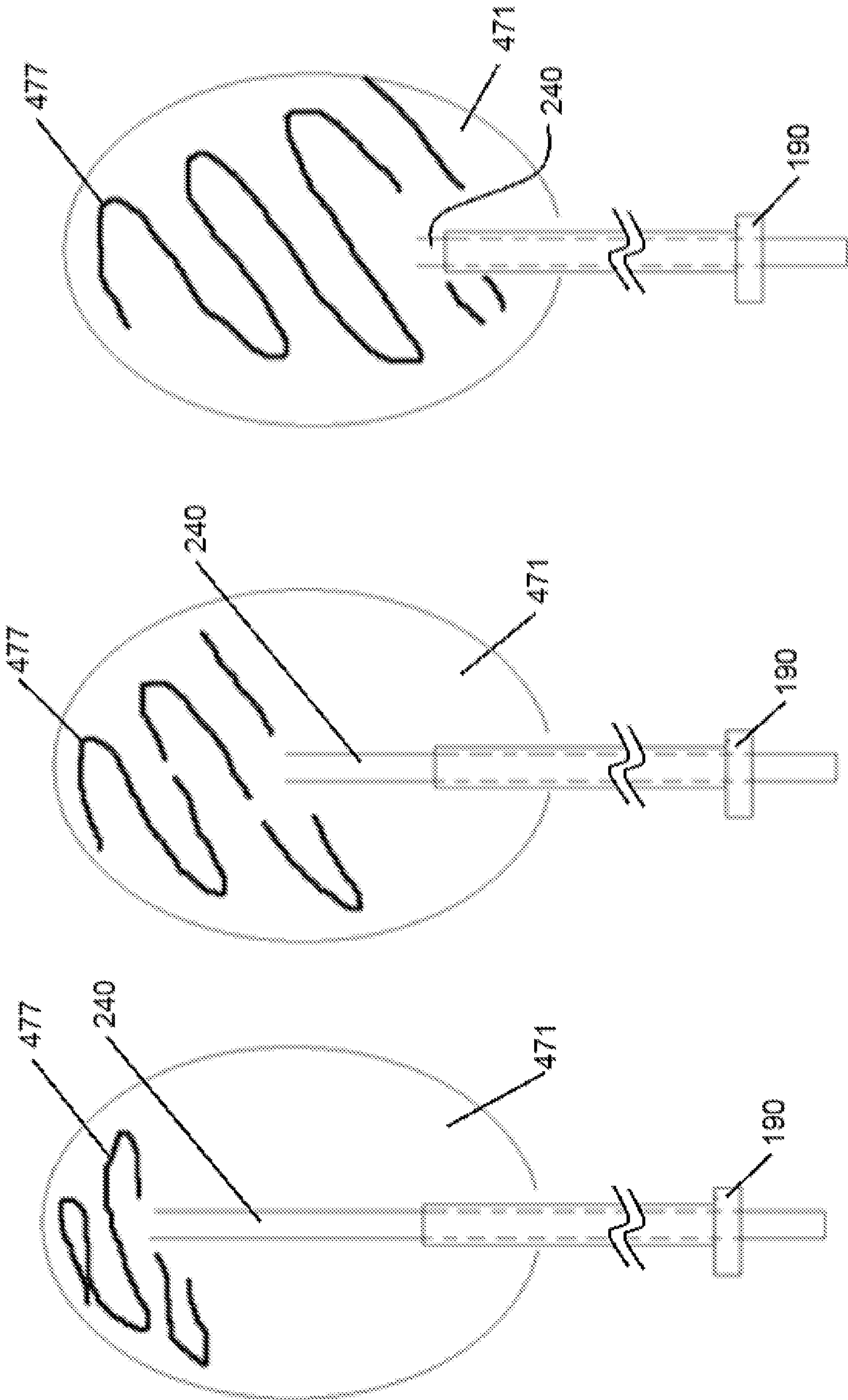
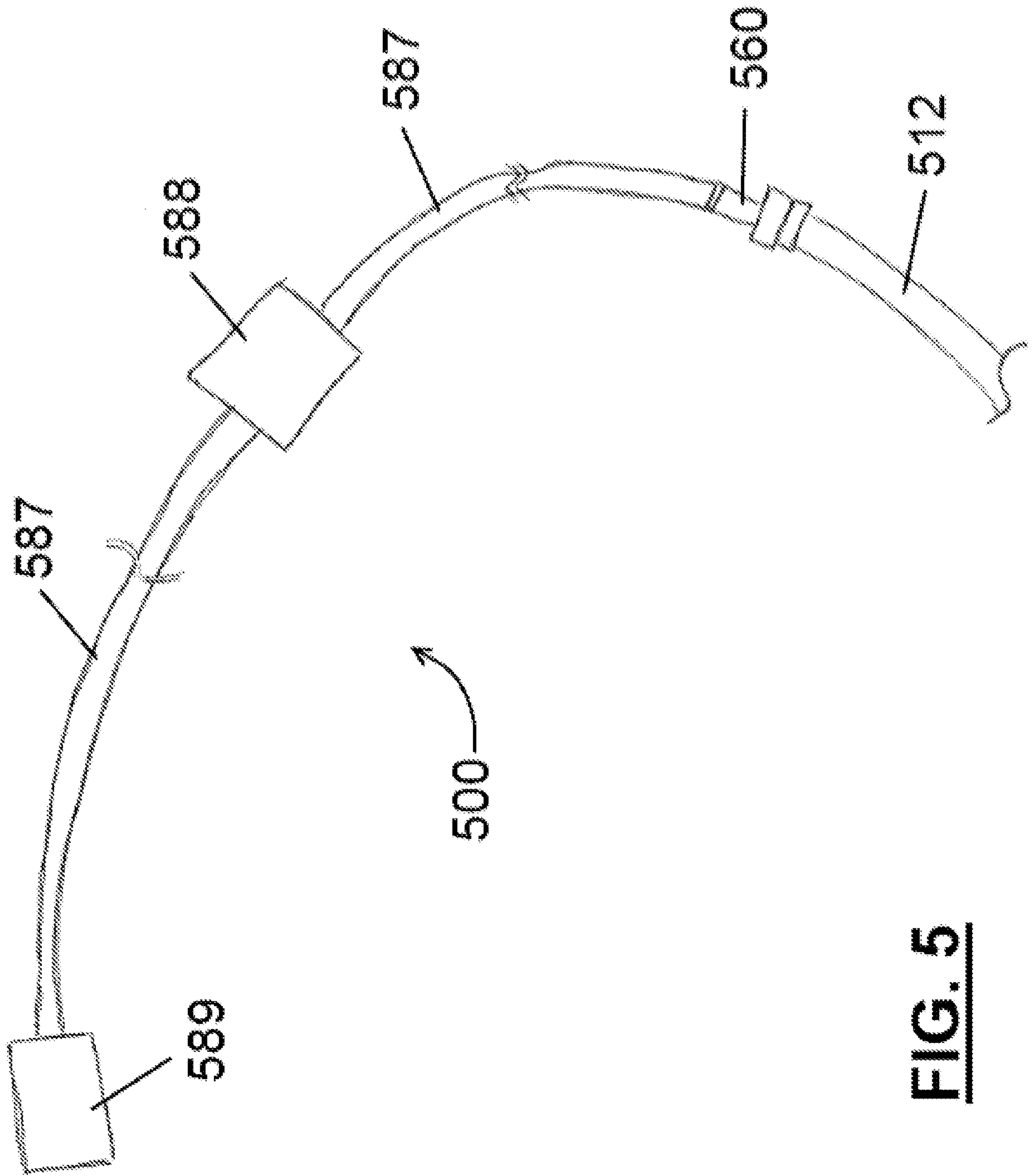

FIG. 4A

FIG. 4B

FIG. 4C



**FIG. 5**

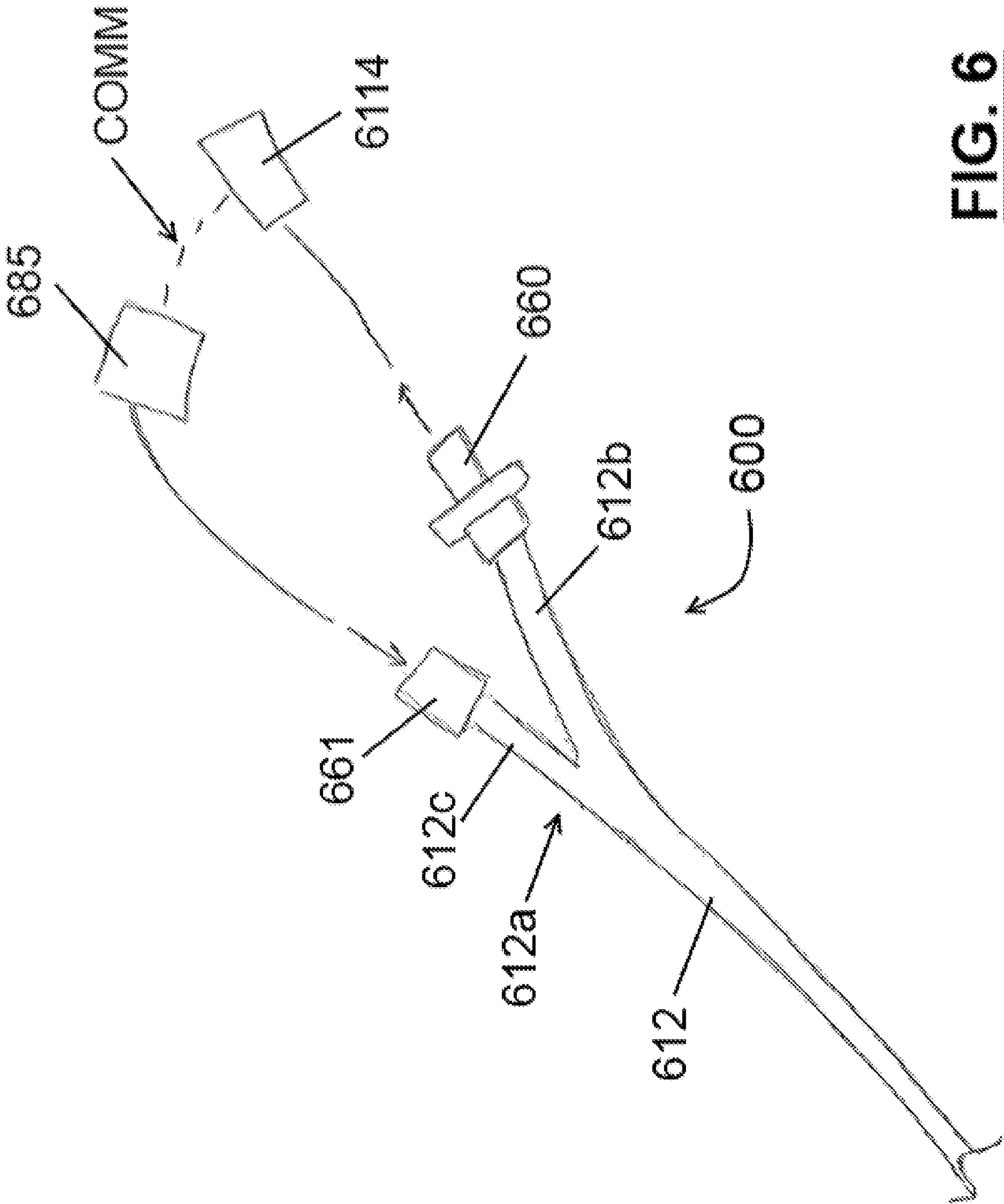

**FIG. 6**

