

J. GRAY.
Sewing Machine.

No. 24,022.

Patented May 17, 1859.

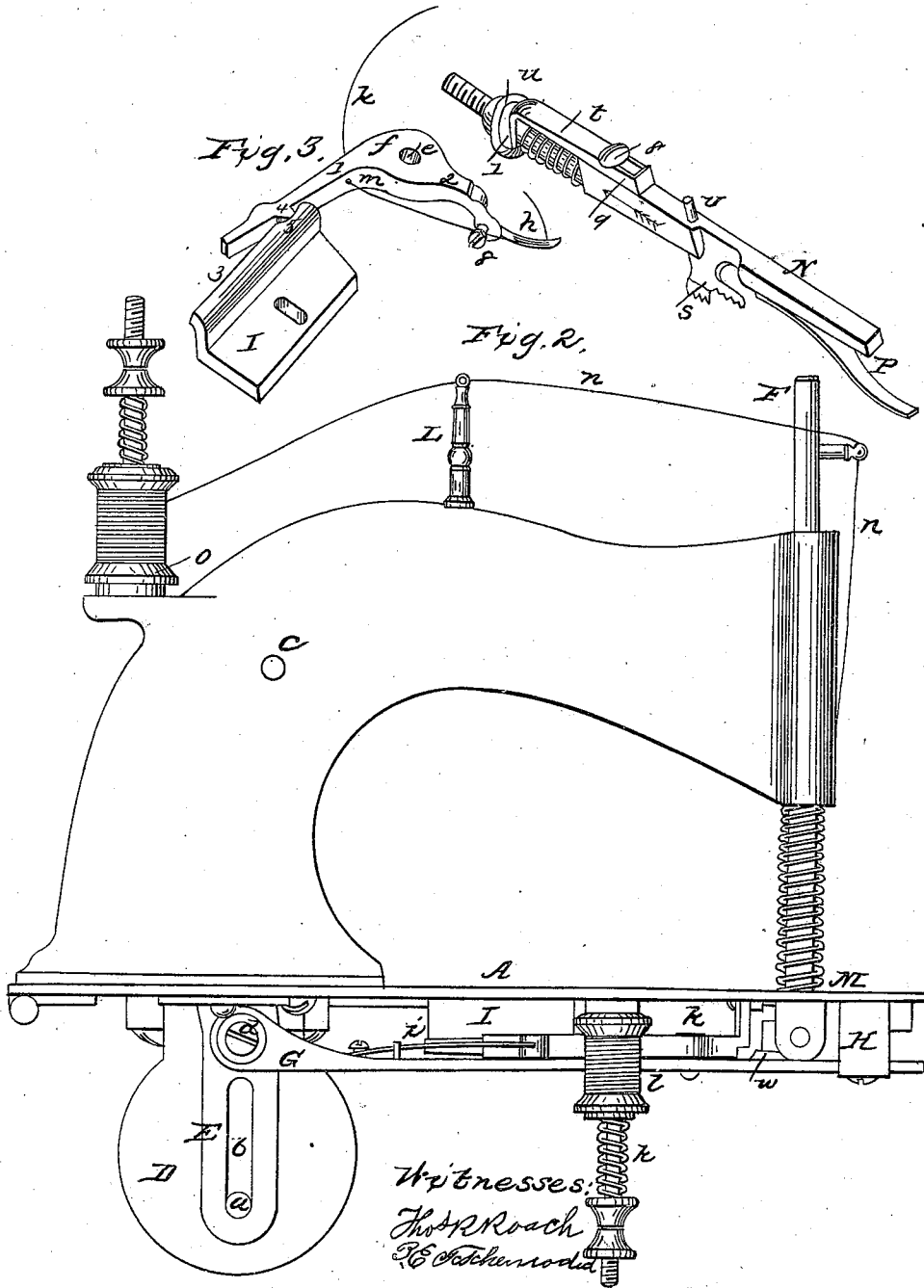

UNITED STATES PATENT OFFICE.

JOSHUA GRAY, OF MEDFORD, MASSACHUSETTS.

IMPROVEMENT IN SEWING-MACHINES.

Specification forming part of Letters Patent No. 24,022, dated May 17, 1859.

To all whom it may concern:

Be it known that I, JOSHUA GRAY, of Medford, county of Middlesex, in the State of Massachusetts, have invented certain new and useful Improvements in Sewing-Machines; and I do hereby declare that the following is a full and exact description thereof, reference being had to the accompanying drawings, and to the letters of reference marked thereon.

My invention is upon that class of sewing-machines which form a double-looped stitch with two threads, and is designed to attain precision and certainty of action with the greatest simplicity of mechanism; and it consists in certain details of construction, which will now be fully set forth and described.

That others skilled in the art may understand and use my invention, I will proceed to describe the manner in which I have carried out the same.

In the drawings, Figure 1 is a plan of the under side of the machine. Fig. 2 is a side elevation of the machine, and Figs. 3, 4, and 5 details to be referred to hereinafter.

A represents the bed-plate of the machine, to the under side of which are secured two short stands, B B, which serve as bearings for the shaft C. This shaft carries on one end the driving-pulley D, which is operated from the treadle in the customary manner. A crank-pin, *a*, placed on the face of the wheel D, enters a slot, *b*, in a bent arm, E, which is pivoted at *c*, to the frame of the machine, and is thus vibrated by the revolution of the wheel D. This communicates a vertical motion to the needle-bar F, connected in a suitable manner to the other end of the arm E. A side bar, G, is pivoted at one end, at *d*, to the arm E, the other end playing in a suitable slot in a block, H, attached to the bed-plate. Thus the vibration of the arm E slides the bar G back and forth beneath the bed-plate. A bent lever, *f*, having a long arm, 1, and a shorter arm, 2, (see Fig. 3,) is pivoted at *e* to the bar G, on the side next the bed-plate, and is vibrated at proper intervals, by the motions of the bar G, in the following manner: An adjustable block or cam, I, is secured by a screw and slot at *g*, to the bed-plate. The arm 1 of the lever *f* is held in contact with the edge 3 of the cam I by a spring, *i*, attached to the bar G. A notch, 5, in the edge 3, receives a stud, 4, on the arm 1, and gives the

required throw to the arm 2 of the lever *f*. This latter arm is bent up, as in Figs. 1 and 3, toward the bed-plate, and carries at its outer end a bent needle or hook, *h*, which is secured to the arm by a screw, *b*. By means of the universally-adjustable stop (and guides) I, the throw of the lower hook is regulated at pleasure, and also the direction of its motion, as may be deemed expedient in adjusting the machine for operation, or in replacing the lower needle, *h*. A post, K, descending from the bed-plate, is furnished with the ordinary screw-nuts and spring for regulating the tension of the thread. It carries a spool, *l*, the thread *k* from which (shown in red) is led through a hole, *m*, in the lever *f*, and thence through the eye of the needle *h*. Another thread, *n*, (in blue,) from a spool, *o*, is led through a hole in the top of the needle-bar F and down through the eye of the needle at the lower end of this bar.

The following is the device which I employ for feeding the goods and regulating the length of stitch: The presser-bar M, Fig. 2, being of the ordinary construction, need not be here described. A sliding bar, N, (detached in Fig. 4,) is supported and vibrates longitudinally in two studs or blocks, *q* and *r*, attached to the under side of the bed-plate, the slot in the block *r* allowing the bar to rise and fall toward and from the bed-plate. A spring, *p*, attached to this bar presses it away from the bed-plate. The feeding-foot *s* is attached to this bar near the middle of its length, and projects through a suitable slot in the bed-plate. To the bar N is attached, near one end, an adjustable stop, *t*, a portion of which is bent down, and embraces the bar at *7*, and a screw, 8, passing through a slot, 9, in the stop allows the stop to be moved longitudinally by means of a screw-nut, *u*, on the bar. The position of this stop regulates the distance to which the bar N will be vibrated, and consequently the length of the stitch. The longitudinal motions are given to the bar N by an incline, 10, on the side of the bar G, striking against the end of the stop *t*, which moves the bar in the direction of the arrow, Fig. 4, until arrested by the nut *u*, striking against the block *q*. Another incline, 11, on the opposite edge of the bar G, strikes as the bar is drawn back, against a pin, *v*, on the bar N, and moves it in the opposite direction. The foot *s* is

pressed up through the slot in the bed-plate and against the under side of the goods (at the instant before the bar N is moved by the incline 10) by a wedge or incline, *w*, Fig. 2, attached to the slide G, which lifts the feed-bar against the resistance of the spring *p*.

It will be observed from the foregoing description of the construction of my improved machine that the greatest degree of certainty and perfection is induced by the least number of parts of simple construction and arrangement together. The reciprocating bar G, it will be seen, operates directly both the feeding device and lower hook or needle mechanism, and is itself driven simply by the vibrating arm E, which operates the upper needle-bar.

The operation of this machine is as follows: The upper needle descends through the goods and forms a loop, 1, Fig. 5, through which the lower needle passes with the thread *k*. The upper needle ascends, and after the cloth is fed passes down through the loop 2 of the lower needle. The latter is then withdrawn, leaving its loop 2 around the upper needle, and before this needle is withdrawn the lower one is passed through its loop 3. The upper needle is then withdrawn and descends through the loop 4 of the lower needle, and the operation continues as before. The motion of the

slide G carries the hole *m* in the lever *f* back past the line of the spool *l*, and draws up the slack of the thread *k*, in the same manner as the throw of the needle-bar F, above the line of the hole in the post L, draws up the slack of the thread *n*, thus dispensing with the use of springs for taking up the slack of either thread.

Having described the construction and operation of my improvement, what I claim as my invention, and desire to secure by Letters Patent, is—

1. The combination of the reciprocating bar G, with its side inclines, 10 and 11, and upper incline, *w*, with the feed-bar N, stop *v*, and adjustable stop *t*, arranged and operating as herein described, for the purpose set forth.

2. In combination with the slide-bar G, which operates the feeder, the bent lever *f* and universally-adjustable cam L, the several parts being arranged to operate substantially as described, for the purpose set forth.

In testimony whereof I have hereunto set my hand this 13th day of November, 1858.

JOSHUA GRAY.

Witnesses:

THOS. R. ROACH,

P. E. TESCHEMACHER.