

Sept. 17, 1968

D. J. EVANS

3,402,117

ELECTRODES AND ELECTRODE STACKS FOR ELECTROLYTIC CELLS

Filed Oct. 25, 1965

2 Sheets-Sheet 1

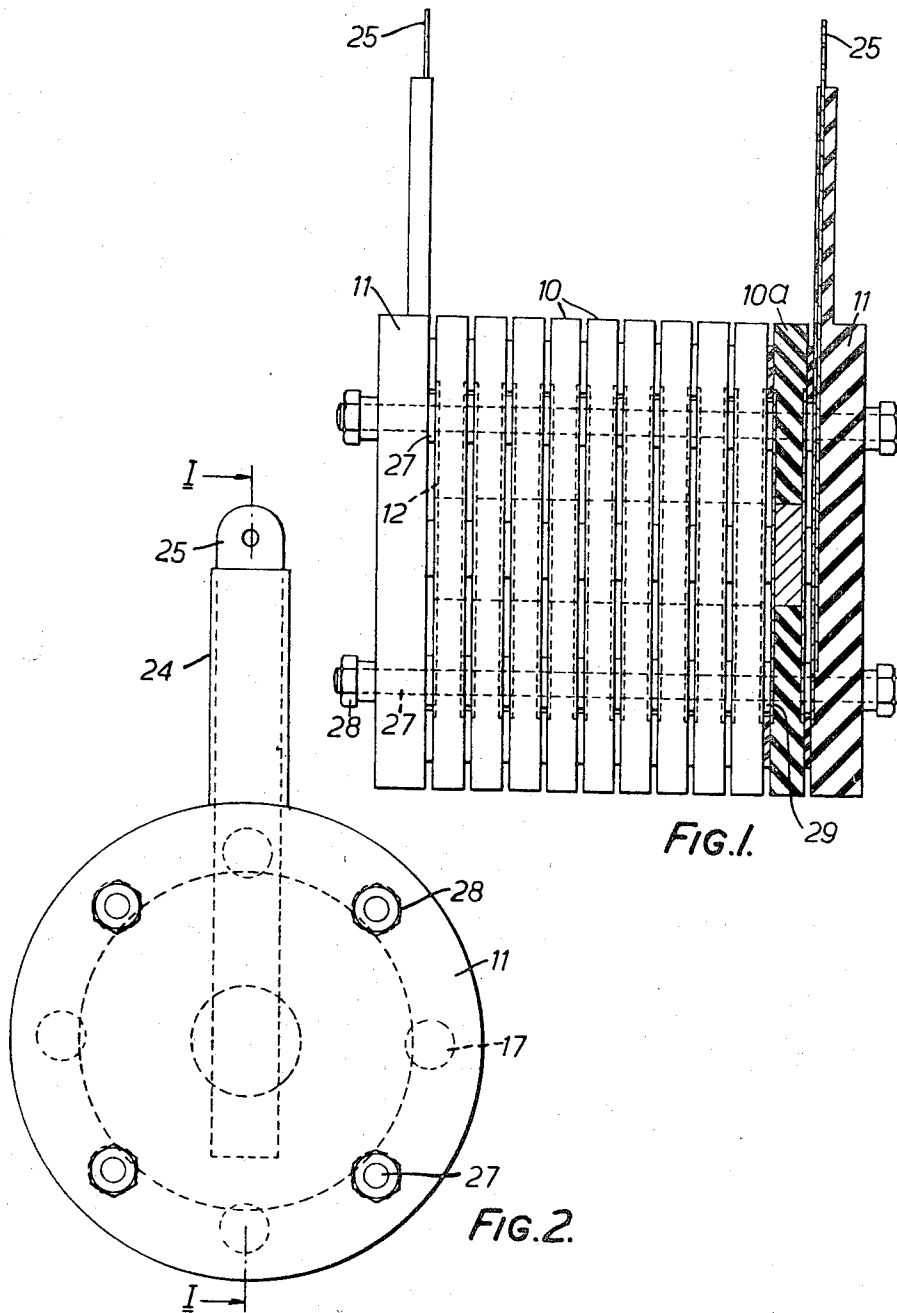

FIG. 1.

FIG. 2.

INVENTOR
David Johnson Evans

BY
Stevens, Davis, Miller & Mosher

ATTORNEY

Sept. 17, 1968

D. J. EVANS

3,402,117

ELECTRODES AND ELECTRODE STACKS FOR ELECTROLYTIC CELLS

Filed Oct. 25, 1965

2 Sheets-Sheet 2

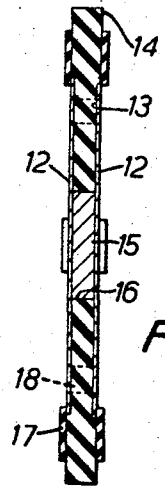
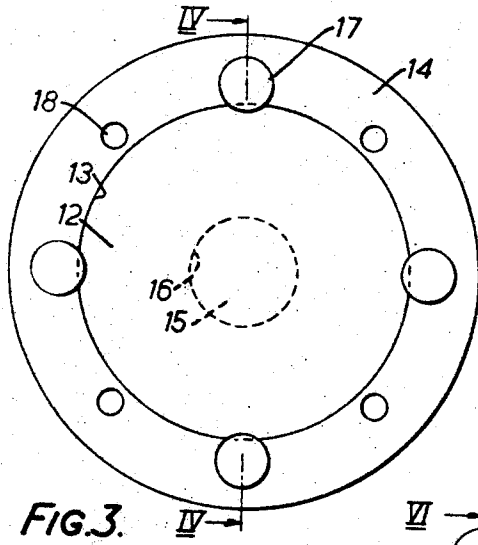

FIG. 4.

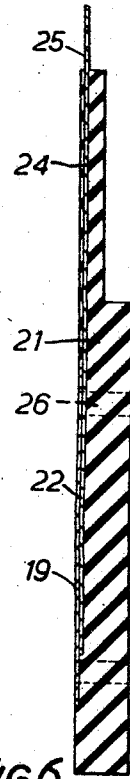
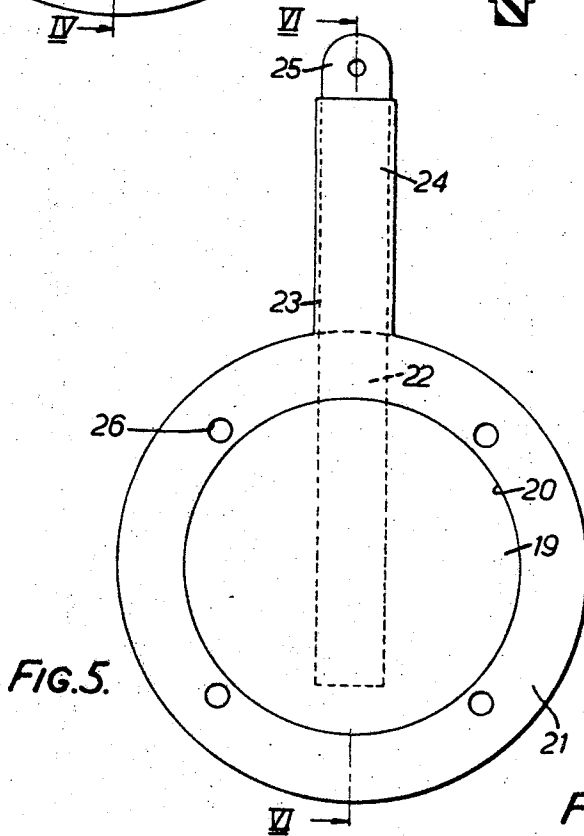

FIG. 6.

INVENTOR

David Johnson Evans

BY

Stevens, Davis, Miller & Mosher

ATTORNEY

1

2

3,402,117

**ELECTRODES AND ELECTRODE STACKS
FOR ELECTROLYTIC CELLS**

David Johnson Evans, Town Mills, Cannon Lane,
Tonbridge, Kent, England

Filed Oct. 25, 1965, Ser. No. 505,186

Claims priority, application Great Britain, Nov. 5, 1964,
45,088/64

18 Claims. (Cl. 204—268)

ABSTRACT OF THE DISCLOSURE

A bipolar electrode for use in an electrolytic cell and comprising at least two substantially identical metal sheets separated by a plate of electrically insulating material to form a stack. The insulating plate has recesses on either side thereof to receive the sheets therein as well as to substantially enclose the peripheries thereof. At least one metal connection passes through the insulation plate at a point spaced from the edges of the stack to interconnect the metal sheets.

This invention relates to electrodes for use in electrolytic cells and relates more particularly to bipolar electrodes for use in electrolytic cells of the multi-plate type, this is to say cells having a plurality of bipolar electrodes arranged in a stack, each electrode being parallel to but spaced apart from its neighbours, and the two end electrodes of the stack being connected to a source of current, so that each of the intermediate electrodes in the stack acts as a cathode at one face and an anode at the opposite face, current being conveyed across the stack of electrodes through the intermediate electrodes and the electrolyte located between each pair of electrodes.

It has previously been proposed to use as such bipolar electrodes a single sheet or plate of an electrically conducting material, such as, for example, graphite, or a suitable metal, for example, titanium or platinised titanium. While such electrodes, and particularly those made of platinised titanium, are suitable for many electrolytic purposes, in some applications, particularly in the electrolysis of brine or sea-water to produce chlorine or hypochlorite, they have been found to have the disadvantage that deposits of hydrate formed from magnesium and calcium salts present in the water, tend to be deposited at the edges of the electrodes, this effect being aggravated by the fact that the cathodic and anodic portions of the plate are in juxtaposition at the edges. There is also a tendency for the edges of the plate to be attacked by the electrolysis products. In order to overcome these disadvantages, it has been proposed to "edge-seal" the edges of the electrode plates, for example, by covering the edges with a layer of a suitable electrically insulating material, or by the use of extender plates of electrically insulating material covering the edge and extending outwardly for a considerable distance from the edge of the electrode. The use of such edge sealing serves to prevent electrical rupture as a result of leakage paths causing concentrated areas of high E.M.F., and also to hinder the formation of hydrate deposits and to even out the passage of current across the electrode stack by the elimination of leakage current at the edges of the electrode which would otherwise tend to produce a situation in which the major part of the current was carried by the electrodes towards the two ends of the stack, whilst the central electrodes carried substantially less current, thus reducing the efficiency of the stack taken as a whole.

It is an object of the present invention to provide a bipolar electrode, particularly for use in the electrolysis of sea-water or brine solution to produce chlorine or hypo-

chlorite, in which the danger of electrochemical attack at the edges of the electrode is substantially reduced or entirely prevented, and which can be used to form an electrode stack of high electrical efficiency.

According to the present invention, a bipolar electrode for use in an electrolytic cell comprises two metal sheets having the same dimensions and shape separated by a plate of electrically insulating material, wherein the insulating plate extends outwardly for an appreciable distance beyond the edges of the metal sheets and wherein the metal sheets are electrically interconnected at one or more points spaced from their edges by one or more metal connections extending through one or more apertures in the insulating plate.

The metal sheets may be of any desired shape, for example, rectangular or square, but it is preferred to use circular plates, since at the corners of square or rectangular plates there is a high concentration of force which may lead to a very strong attack on the plates at these points. When circular metal plates are used, the insulating plate will normally also be circular in shape and will be mounted concentrically with the metal sheets. In such a case, the electrical connection between the two metal plates may conveniently be established by a metal disc or rod passing through a central aperture of corresponding diameter in the insulating plate and connected in any suitable way to each of the metal plates, for example, by welding.

The choice of the metal to be used for the sheets forming the two faces of the electrode will be determined by the particular electrolysis process for which the electrode is to be used. Where the electrodes of the present invention are to be used in a cell for the electrolysis of sea-water or brine, they are conveniently made of titanium, the outer face of that sheet which in use will form the anode being covered with a thin coating of platinum. Alternatively, the metal sheets may be of nickel or a nickel alloy, the anode face of the electrode again being covered, if desired, with a coating of platinum. Other materials which may be used are sheets of rhodium or ruthenium which again may if desired be provided with a coating of platinum on the anode face. Finally, sheets of platinum itself may be used to form the electrode. The metal connection will normally be made of the same metal as is used for the plates.

The insulating plate may be of any suitable insulating material, such as a synthetic resinous material. Examples of such synthetic resinous materials are polypropylene and polytetrafluoroethylene, but the preferred synthetic resinous material is an acrylic resin, since such resins are capable of taking a high surface polish which assists in preventing the formation of hydrate deposits thereon.

Alternatively, the insulating plate may be made from an ion-permeable material, for example, an anion-permeable material, or from a combination of resinous material as described above faced with an ion-permeable material. The use of such a material has the advantage that the material tends to repel cations, which phenomenon assists in preventing the build-up of hydrate deposits on the edges of the metal sheets.

In order that the edges of the metal sheets should be completely protected, it is preferred that the sheets should be located in recesses in the opposite faces of the insulating plate, these recesses being so dimensioned that the edge of the metal sheet is in contact with the inner periphery of the recess.

In use, a number of electrodes according to the invention are arranged to form an electrode stack, opposing metal faces of each of the electrodes being separated by suitable spacing members which may be conveniently constituted by a number of small discs made of the same material as the insulating plate and attached to at least one

face of the plate around the periphery of the metal sheet. These discs may project slightly over the face of the sheet and serve to hold the sheet firmly in the recess in the plate. At either end of the electrode stack is a unipolar electrode which may conveniently consist of a single metal sheet held in a recess on one face of a plate of insulating material. The end electrodes are arranged to be connected to the two poles of a source of direct current. The individual electrodes forming the electrode stack may be held together by any suitable means. A convenient means consists of a number of bolts, each bolt passing through registering apertures in the portions of the insulating plates which extend beyond the periphery of the metal sheets.

The electrode stacks formed from the electrodes of the present invention may be used in either open electrolytic cells or in closed cells. When used in an open electrolytic cell, the electrode stack is self-circulating, since, as soon as the current is switched on, circulation of the electrolyte between the electrodes takes place. The electrode stack may be mounted in any position within the cell, either with the electrodes vertical or horizontal or at an angle to the vertical or less than 90 degrees.

One form of bipolar electrode in accordance with the invention is illustrated in the drawings, in which:

FIGURE 1 is a side view, partly in section along the line I—I of FIGURE 2, of an electrode stack including bipolar electrodes according to the invention;

FIGURE 2 is an end view of the electrode stack of FIGURE 1;

FIGURE 3 is a plan view of the bipolar electrode shown in section in FIGURE 1;

FIGURE 4 is a section along the line IV—IV of FIGURE 3;

FIGURE 5 is a plan view of one of the end electrodes of the electrode stack of FIGURE 1; and

FIGURE 6 is a section along the line VI—VI of FIGURE 5.

Referring to FIGURE 1, an electrode stack consists of ten bipolar electrodes 10, one of which 10a is shown in section, and two unipolar electrodes 11 located at either end of the stack and adapted to be connected to the poles of a direct current supply. The electrodes are mounted to form the stack parallel with one another but spaced apart.

The construction of each of the bipolar electrodes is shown more clearly in FIGURES 3 and 4. Each electrode 10 consists of a pair of thin circular sheets 12 made of titanium, the two sheets serving in use as the anode and the cathode respectively of the composite electrode. The sheets 12 are housed within concentric recesses 13 formed in the opposed faces of a circular spacer plate 14 made of an acrylic resin and having a diameter considerably greater than that of the sheets 12, each recess 13 being of such dimensions that the sheet 12 will fit exactly within the recess with the outer periphery of the sheet in contact with the inner periphery of the recess and with the outer face of the sheet substantially flush with the surface of the plate 14. The outer face of the sheet 12 which in use will form the anode of the bipolar electrode is preferably covered with a thin coating of platinum.

The two sheets 12 are electrically connected with each other by means of a titanium disc 15 of thickness equal to the plate 14 less the total thickness of the two sheets 12 to which each sheet is spot welded. The disc 15 is housed in a central aperture 16 of suitable diameter in the plate 14.

As shown in FIGURE 4, the electrode 10a is provided with eight spacers 17 in the form of discs of the acrylic resin, four of which are attached to each side of the plate 14 at spaced intervals about the periphery of the sheet 12. The spacers 17 project slightly over the face of sheet 12 and thus serve to hold it firmly within the recess 13.

Only the electrode immediately adjacent to one of the end electrodes (in FIGURE 1, electrode 10a) is provided

with spacers 17 on both faces. The remaining electrodes forming the stack are provided with spacers on one face only. By this means, the distance at which any two electrodes are spaced apart is always equal to the thickness of the spacers 17. The spacers also ensure that the electrodes are correctly assembled to form the stack and assist in avoiding the possibility of an anodic pole being placed opposite another anodic pole.

The portion of the plate 14 which projects beyond the sheets 12 is provided with four holes 18 spaced around the plate between the spacers 17, by means of which the electrodes 10 are held together to form the electrode stack as will hereinafter be described.

The construction of the end electrodes 11 is illustrated in FIGURES 5 and 6. The electrode consists of a circular sheet 19 of titanium of the same diameter as the sheets 12 located within a corresponding recess 20 in one face of a plate 21 of insulating material of the same diameter as the plate 14. The sheet 19 is spot welded to a titanium strip 22 also housed within a recess 23 in the plate 21 and a suitably shaped projection 24 thereof. The end of the strip 22 projects beyond the end of the projection 24 to form a terminal 25 for connection to the source of direct current. Again, the outer face of the sheet 19 which in use serves as anode is preferably coated with a thin layer of platinum. In this case, the plate 21 may conveniently be made of polyvinyl chloride.

While in the embodiment illustrated in the drawings the terminals are formed by the ends of the projections 24, such an arrangement being very suitable when the electrode stack is to be used in an open cell, it may be more convenient when the stack is to be used in a closed cell, to provide connections to the centre of each of the end electrodes, these connections extending centrally through the plate 21 to form the necessary terminals.

The plate 21 is provided with holes 26 corresponding in position to the holes 18 of the plates 14.

Referring now again to FIGURES 1 and 2, the bipolar electrodes 10 and the end electrodes 12 are connected by bolts 27 passing through the holes 18 and 26 in the electrodes 10 and the end electrodes 12 respectively. The ends of the bolts 27 are threaded to receive nuts 28 which when tightened secure the individual electrodes together to form the electrode stack. Spacers 29 made of insulating material and of the same thickness as the spacers 17 are located on the bolts 27 between each pair of electrodes.

What I claim as my invention and desire to secure by Letters Patent of the United States is:

1. A bipolar electrode for use in an electrolytic cell and comprising two metal sheets having the same dimensions and shape separated by a plate of electrically insulating material, said insulating plate extending outwardly for an appreciable distance beyond the peripheries of the metal sheets, recesses formed in opposite faces of said insulating plate for housing said metal sheets therein, the depth of said recesses being substantially equal to the thickness of the metal sheets and being so shaped and dimensioned that the edge of each of said metal sheets is in contact with the inner periphery of the recess within which it is housed, and at least one metal connection electrically interconnecting said metal sheets at at least one point spaced from the edges of said sheets and extending through at least one central aperture of corresponding diameter in said insulating plate.

2. A bipolar electrode according to claim 1, wherein said metal plates are circular in form.

3. A bipolar electrode according to claim 2, wherein said insulating plate is also circular in form and is concentric with said metal sheets.

4. A bipolar electrode according to claim 1, wherein said at least one metal connection is made of the same material as the metal sheets.

5. A bipolar electrode according to claim 1, wherein said metal sheets are made of titanium.

5

6. A bipolar electrode according to claim 5, wherein the outer face of that metal sheet which in use forms the anode is covered with a thin coating of platinum.

7. A bipolar electrode according to claim 1, wherein said insulating plate is made of a synthetic resinous material.

8. A bipolar electrode according to claim 7, wherein said insulating plate is faced with an ion-permeable material.

9. A bipolar electrode according to claim 7, wherein said insulating plate is made of an acrylic resin.

10. A bipolar electrode according to claim 9, wherein said insulating plate is given a high surface polish.

11. A bipolar electrode according to claim 1, wherein said insulating plate is made of an ion-permeable material.

12. An electrode stack for use in an electrolytic cell and comprising a plurality of bipolar electrodes according to claim 1 arranged in parallel spaced relationship and in register, and a unipolar electrode arranged at either end of said stack, each said unipolar electrode having means for connecting it to one pole of a source of direct electric current.

13. An electrode stack according to claim 12, wherein each said unipolar electrode comprises a metal sheet of the same dimensions and shape as the metal sheets of said bipolar electrodes housed within a recess in one face of a plate of electrically insulating material.

14. An electrode stack according to claim 13, wherein said connecting means comprises a metal strip housed for part of its length in the insulating plate of said unipolar electrode and in electrical contact with the metal sheet of said unipolar electrode.

15. An electrode stack according to claim 13, wherein

6

the individual electrodes are held together to form the stack by means of bolts passing through registering apertures in the portions of the insulating plates which extend beyond the peripheries of the metal sheets.

16. An electrode stack according to claim 13, wherein said bipolar electrodes are spaced from each other by means of spacing members of insulating material attached to that portion of one face of the insulating plate of each bipolar electrode which extend outwardly beyond the peripheries of the metal sheets and spaced around the periphery of the metal sheet, said spacing members abutting against a face of an adjacent electrode not provided with such spacing members.

17. An electrode stack according to claim 16, wherein said spacing members are in the form of small discs made of the same material as the insulating plate.

18. An electrode stack according to claim 17, wherein the metal sheet associated with the face of the insulating plate to which said spacing members are attached is housed within a recess in said face and wherein said discs project slightly over the face of said metal sheet to hold it firmly in said recess.

References Cited

UNITED STATES PATENTS

522,839	7/1894	Knöfler	204—268
831,434	9/1906	Hinkson	204—268
806,413	12/1905	Kother	204—268
3,276,911	10/1966	Schoenewis	204—290 XR
3,331,763	7/1967	Mabey	204—290

JOHN H. MACK, *Primary Examiner.*

D. R. JORDAN, *Assistant Examiner.*