

*B. Rowell,
Portable Fence,*

N^o 58,193.

Patented Sept. 18, 1866.

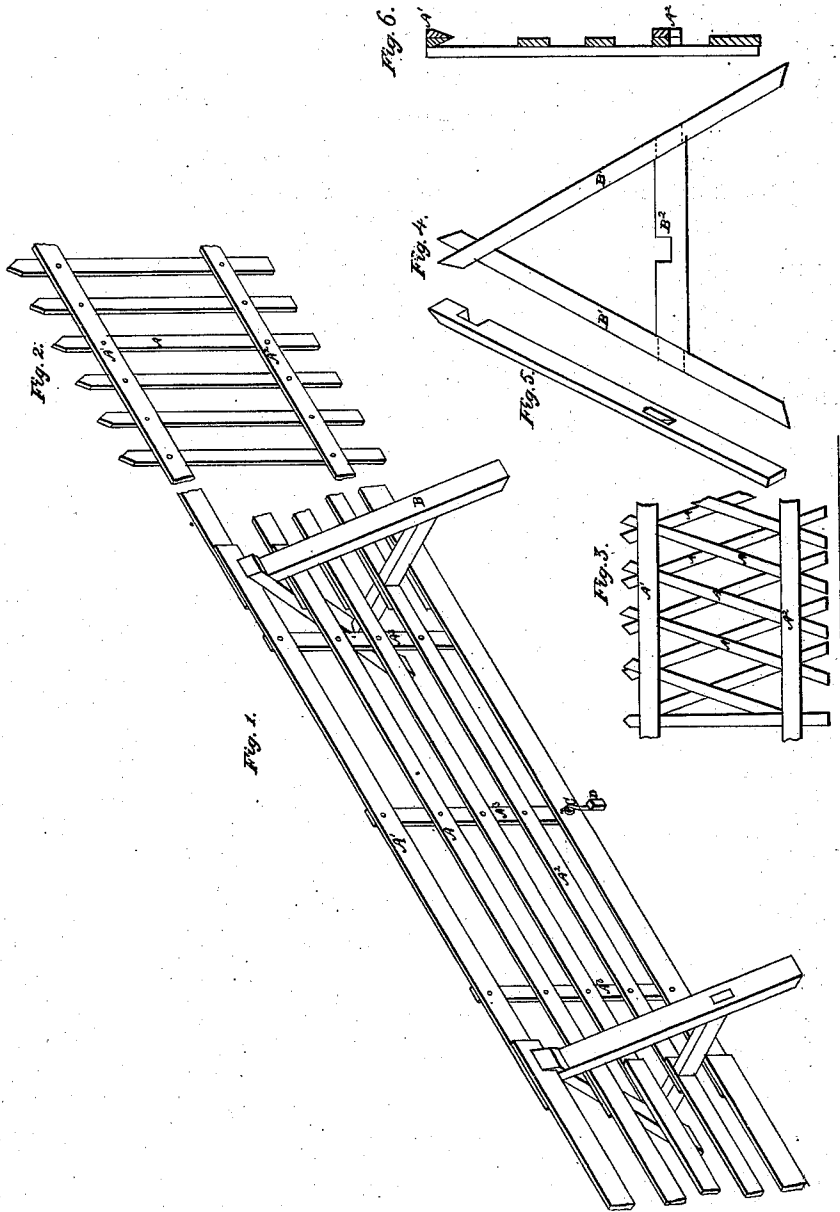

*Witnesses.
By *Lawrence Murphy**

*Inventor
Benning Rowell
By *D. P. Mottaway* & Co.
his Atty.*

UNITED STATES PATENT OFFICE.

BENNING ROWELL, OF ELMIRA, NEW YORK.

IMPROVEMENT IN FENCES.

Specification forming part of Letters Patent No. 58,193, dated September 18, 1866.

To all whom it may concern:

Be it known that I, BENNING ROWELL, of Elmira, county of Chemung, and State of New York, have invented a new and useful Improvement in Portable Fences; and I do hereby declare that the following is a full, clear, and exact description of the same, reference being had to the annexed drawings, making part of this specification, in which—

Figure 1 is a perspective view; Figs. 2 and 3, views showing various forms of constructing the panels; Fig. 4, a side elevation of a post; Fig. 5, a side view of one of the pieces constituting the post; Fig. 6, a vertical section of a panel.

The same letters are referred to in indicating identical parts.

The fence consists of a panel, A, supported by brace-posts B, the panel being retained in position by a hook, C, on a post, D.

The panels may be constructed with parallel boards or with pickets, as shown in the Figs. 1, 2, and 3. In the first case the boards composing the panels are fastened to cross-pieces A³. In the other cases they are fastened to the rails A' and A².

The posts are framed in the form of a letter A, with the sides produced and crossed. The pieces B' are notched, as shown in Fig. 5, on their opposing faces, the notches being each cut to one-half the depth of the pieces, so that the pieces shall be firmly locked when put together.

The tie B² has a notch in the middle, as shown in Fig. 4, of the length of double the thickness of the rail A².

The ends of the rails A' and A², or the corre-

sponding board in the form of panel, (shown in Fig. 1,) have beveled notches near their ends, beveled on opposite faces, (shown in Fig. 6.) so that the two rails, as overlapped, may fit exactly into the upper ends of the posts B. The bevels are cut on opposite faces of each board at the different ends, so as to fit the posts on different sides, the rails being crossed in putting up the fence, so that only one end of each rail shall be seen from one side of the fence.

The rails A² are notched to fit into the notches in the tie B², the two rails filling the latter notch. The rails are set so as to be on opposite sides of the connecting-boards at the different ends.

The panels, duly framed, are hung at each end upon the posts B, as shown, and are secured firmly in place by a hook, C, fastened to a short post, D, and catching into an eye on the lower rail or board.

What I claim as my invention, and desire to secure by Letters Patent, is—

A portable fence so constructed that the boards or rails A' and A², supporting the panels, shall be interlocked and sustained upon posts B and be held in place by intermediately-placed hooks C, fastened to short posts D, and arranged to operate substantially as set forth.

In testimony whereof I have signed my name to this specification in the presence of two subscribing witnesses.

BENNING ROWELL.

Witnesses:

BENJ. L. FLETCHER,
D. P. HOLLOWAY.