

(No Model.)

W. H. PENNOCK.
SPRING BED BOTTOM.

No. 384,590.

Patented June 12, 1888.

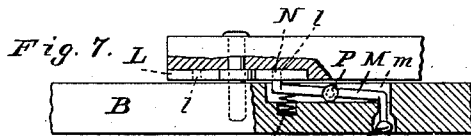
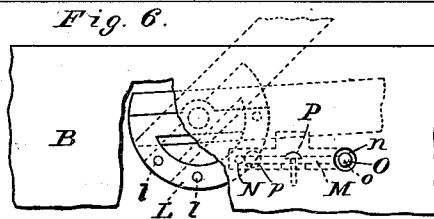
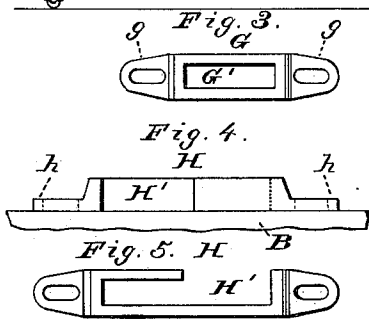
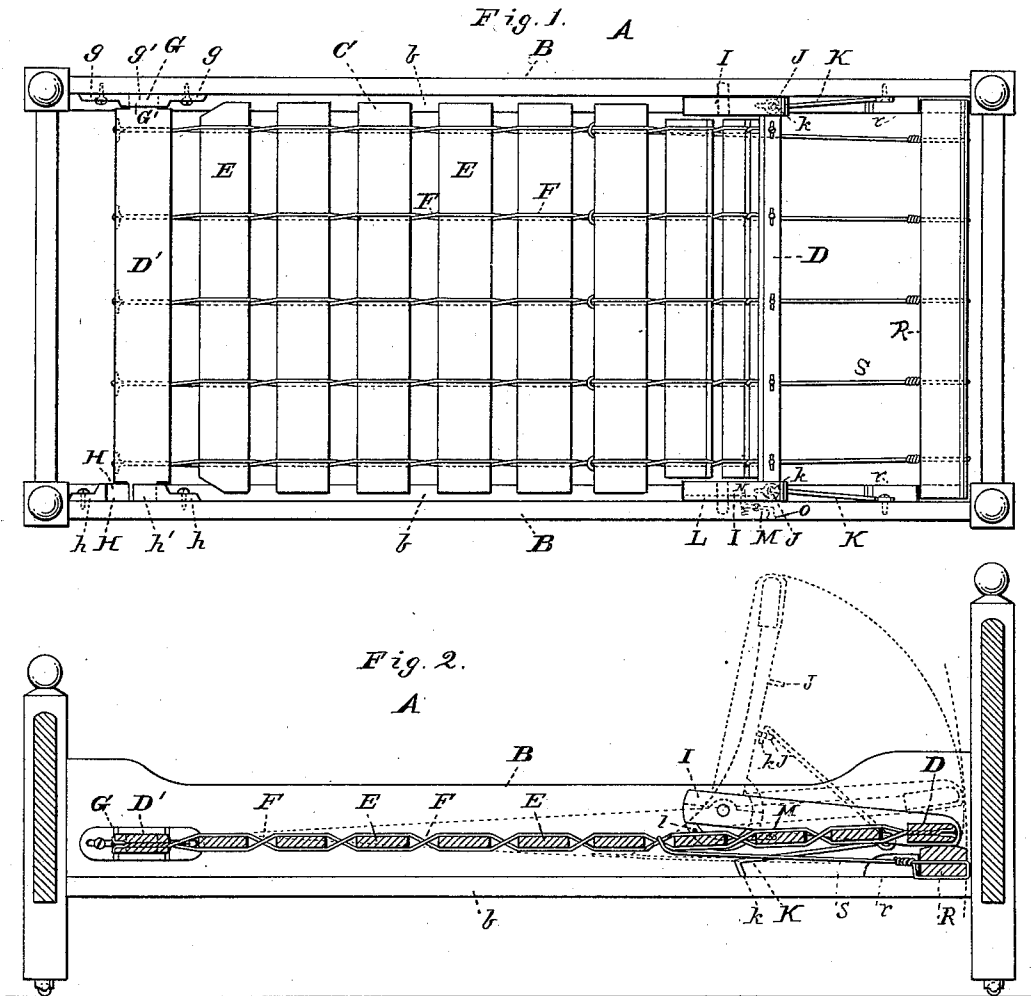

WITNESSES.
Villette Anderson.
W. Ferguson.

INVENTOR.
William H. Pennock.
 by *E. W. Anderson.*

Attorney.

UNITED STATES PATENT OFFICE.

WILLIAM H. PENNOCK, OF MERMAID, DELAWARE, ASSIGNOR OF ONE-HALF
TO JOSEPH W. DERRICKSON, OF SAME PLACE.

SPRING BED-BOTTOM.

SPECIFICATION forming part of Letters Patent No. 384,590, dated June 12, 1888.

Application filed November 26, 1887. Serial No. 256,234. (No model.)

To all whom it may concern:

Be it known that I, WILLIAM H. PENNOCK, a citizen of the United States, and a resident of Mermaid, in the county of New Castle and State of Delaware, have invented certain new and useful Improvements in Spring Bed-Bottoms; and I do declare the following to be a full, clear, and exact description of the invention, such as will enable others skilled in the art to which it appertains to make and use the same, reference being had to the accompanying drawings, and to letters or figures of reference marked thereon, which form a part of this specification.

Figure 1 of the drawings is a representation of this invention, and is a top view. Fig. 2 is a vertical longitudinal section of parts shown in Fig. 1. Figs. 3, 4, and 5 are details, showing a front view of the closed socket, and of the open socket a top and a front view. Figs. 6 and 7 are details, and show the semicircular plate and the spring-controlled detent in side and top views.

The invention relates to improvements in spring bed-bottoms, being especially adapted to be used in connection with a bedstead as an invalid-bed; and it consists in the construction and novel combination of parts, hereinafter described, illustrated in the drawings, and pointed out in the appended claims.

Referring to the drawings by letter, A designates a bedstead having the side rails, B B, from the lower ends of which stand inwardly, preferably for their entire length, the clips *b b*.

C is the spring bed-bottom, composed of the head and foot rails, D D', respectively, and the intervening slats E and the connecting-wires F. The slats are similar and equidistant, and the wires F are arranged longitudinally in pairs, the said pairs being preferably equidistant, and the two outer pairs being near to and at equal distances from the side edges of the bed-bottom. The opposite ends of the wires of each pair pass together through central transverse openings in the head and foot rails, and are secured to pins or screws driven into the outer surfaces of said rails. Inside of said rails the wires are twisted on each other, and then passed, respectively, above and below the adjacent slat, and so on

from end to end of the bed-bottom, each wire of the pair passing alternately above and below the slats from end to end. The wires are usually turned but once on each other between the slats, but may, if desirable, receive more than one turn, and the slats are sufficiently close together and the wires drawn sufficiently tight to give the bottom the proper degree of tension.

The means of attaching the bottom to the bedstead are as follows:

G and H are sockets, preferably of metal, and secured by screws passing through openings in their ears *g* and *h* to the inner surfaces of the side rails, B, at opposite points near the foot-board. The socket G is complete, and receives the uncut end *g'* of the foot-rail D'; but the socket H has its upper side cut away at the end toward the foot of the bedstead, so that the end *h'* of said rail can, after the opposite end *g* of the same has been inserted in the notch G', be easily engaged in the forward or front end of the socket H'.

R designates the anchor-bar, having its ends resting on the clips *b b* of the side rails, and held in place by the stay-blocks *r*, and tension-wires S extend from the anchor-bar to an engagement with the wires F, below the pivotal point of the lever-arms I.

I I are similar and opposite lever-arms pivoted at their outer ends to the opposite ends of the head-rail D of the bed-bottom, and at points equally distant from their inner ends to opposite points on the inner surface of the side rails of the bedstead. The said lever-arms are of such length that the longitudinal tension of the bed-bottom, acting from the foot-rail engaged in the sockets G and H, will hold the head-rail elevated above the plane of the bed-bottom at a suitable height, so that when the said head-rail is pushed downward the longitudinal tension of the bed-bottom is increased to a point where the head and foot rails are in the same plane. After the head-rail has passed that point it springs downward until it rests upon the anchor-bar. Thus the tension of the bed-bottom retains the head-rail down, keeps the bed extended, and does away with the necessity of any special supplementary retaining devices. The lower edges of 100

the lever-arms I are furnished with the eyebolts J, having their eyes set transversely and situated suitable distances apart along said edges.

5 K K are similar opposite supporting-bars, pivoted at their lower ends to opposite points on the inner surfaces of the side rails of the bedstead, suitable distances forward or in front of the lever-arms, and having secured to their
10 upper ends the hooks k k, which engage the eyebolts J, and support the head of the bed-bottom at the height to which it has been set. The said hooks and bolts prevent the position of the said head from being changed until they
15 are disengaged, and are therefore not the equivalents of racks engaging the upper ends of the supporting-arms, which construction would prevent the head-rail from descending without disengagement, but would allow it to ascend.

20 One of the lever-arms I is recessed on its outer surface for the purpose of having secured to it flush with said surface a semicircular plate, L, the curved edge of which is concentric with the pivotal point of said lever-arm, and its straight edge coincident with the upper
25 edge thereof. The said plate is provided near its curved edge with a series of openings, l l, in a line concentric with the pivotal point of the lever-arm, and serving a purpose herein-
30 after explained.

M is a spring-controlled detent pivoted in a longitudinal recess, m, in the side rail of the bedstead adjacent to the plate L. The said detent is provided on one end with the inwardly-standing engaging-point N, and on the
35 other end with the outwardly-standing projection O, having on its end the flat disk or button o, which rests in the opening n, extending outward from the corresponding end
40 of the recess m, and is of diameter large enough for the button to move easily therein. The detent M is pivoted centrally in said recess on the pin P, so as to swing horizontally, and the point N is pressed into any one of the
45 openings l which may be opposite it by the spring p, that rests in the recess and bears on the arm of the detent carrying the engaging-point N. The parts are so arranged that when said point is engaged in an opening, l,
50 the outer surface of the button o is flush with the outer surface of the corresponding side rail, B, so that the button cannot easily be accidentally driven inward, and, by releasing the point N, allow the head rail, D, to fall. To
55 raise or lower the head of the bed, the said button is pressed inward by the finger and the head-rail slightly lifted, when the weight of the invalid below the waist, by increasing the tension of the bed-bottom, will cause the head-rail to rise to the desired point. The button
60 is then released and the point engaged in the opening l brought opposite by the detent-spring

p, thus retaining the head rail in its raised position.

It will be observed that the bed-bottom 65 herein described may be manufactured at a comparatively small cost, that it is easily applied to any bedstead, and that, as there are no side rails confining it when removed from the bedstead, the spring-bottom may be rolled 70 into a compact form for storage or transportation.

Having described my invention, I claim—

1. The combination, with the bedstead, of the bed-bottom composed of the head and foot rails and intervening slats, the longitudinal connecting-wires secured in pairs to the head and foot rails and alternately passing over and under adjacent slats and crossing between the slats, the anchor-bar removably secured to the side bars, the retaining-blocks, the tension-wires extending from said anchor-bar and engaging the wires F, and the lever-arms pivoted near their inner ends to the inner surface of the side rails of the bedstead and at their
85 outer ends to the head rail, substantially as specified.

2. The combination, with the bedstead and the transversely flexible bed-bottom having its foot-rail removably secured to the bedstead near the foot thereof, and having the anchor-bar removably secured to the side bars near the head thereof, of the pivoted lever-arms having the segmental plate thereon, and the eyebolts set transversely on said lever-arms, and the supporting-bars pivoted at their lower ends to the inner surface of the side rails, B, and having the hook ends to engage the transverse eyebolts, substantially as specified. 95

3. The combination of the bedstead, the flexible bed-bottom having the foot-rail D', removably secured to the side rails, B, the anchor-bar removably attached to the side bars near the head thereof, and the tension-wires extending therefrom and engaging the wires F, the lever-arms pivoted near their inner ends to the inner surface of the side rails, B, and at the outer ends to the head-rail D, the semicircular plate secured in the recess and flush with the outer surface of the lever-arms I, the said plate being provided with a series of openings in a line concentric with the pivotal point of the lever-arm, the detent M, pivoted in the recess in the side rail, B, having the engaging point, and the arm D, having the button flush with the outer surface of the side rail of the bedstead, and the spring p in the recess, substantially as specified. 100 105 110 115

In testimony whereof I affix my signature in presence of two witnesses.

WILLIAM H. PENNOCK.

Witnesses:

JOHN G. JACKSON,
ALBERT SPRUCE.