

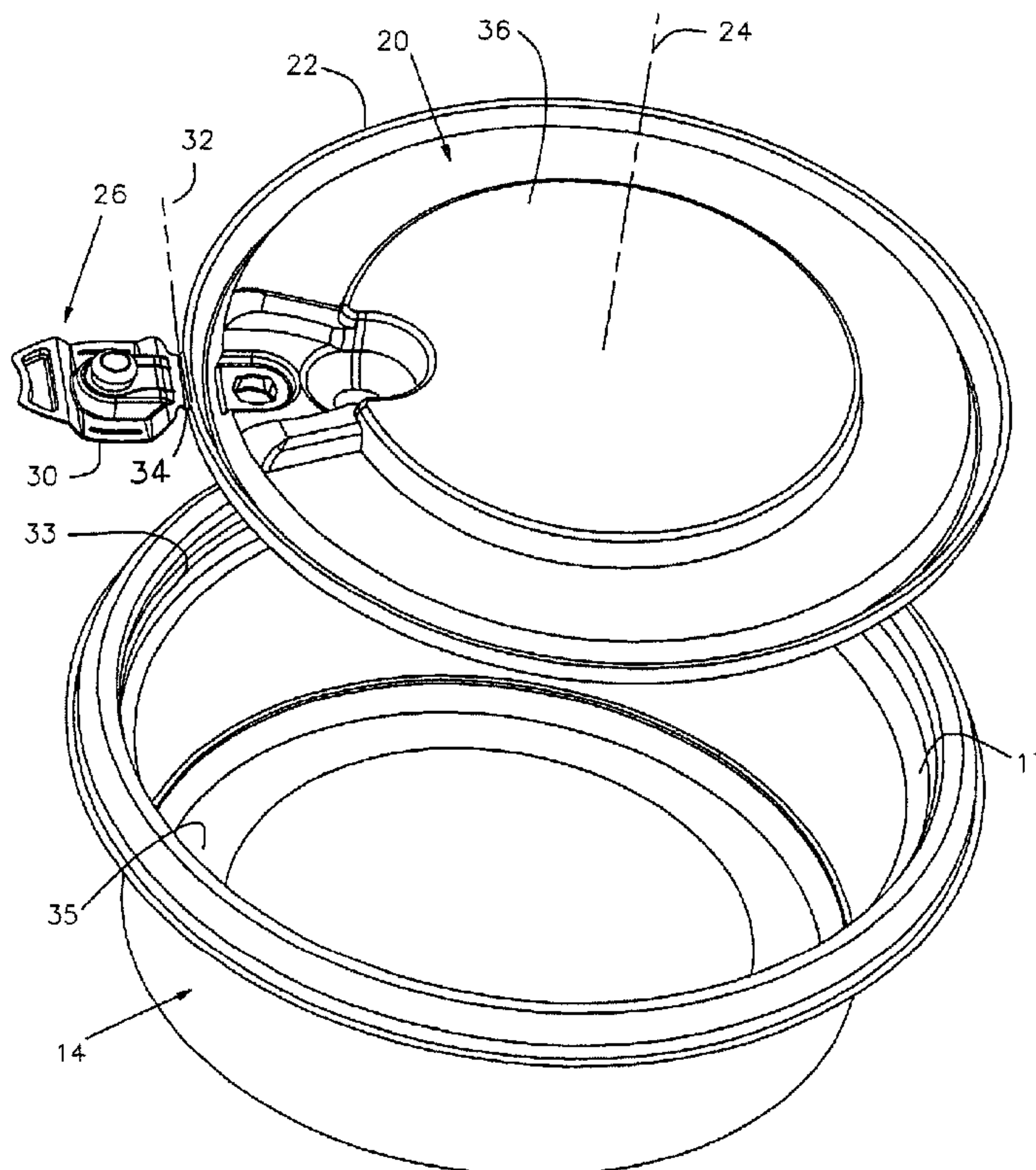

(22) Date de dépôt/Filing Date: 2012/03/21
 (41) Mise à la disp. pub./Open to Public Insp.: 2012/09/22
 (45) Date de délivrance/Issue Date: 2017/04/18
 (30) Priorité/Priority: 2011/03/22 (US13/065,436)

(51) Cl.Int./Int.Cl. *B65D 55/06* (2006.01),
B65B 25/04 (2006.01), *B65B 7/28* (2006.01),
B65D 50/14 (2006.01)
 (72) Inventeurs/Inventors:
 VOVAN, JANE N., US;
 ROSEN, LEON D., US
 (73) Propriétaire/Owner:
 SMART-TAB, LLC, US
 (74) Agent: FETHERSTONHAUGH & CO.

(54) Titre : RECIPIENTS A TEMOIN D'INVOLABILITE
 (54) Title: CONTAINERS WITH TAMPER-EVIDENT FEATURES



(57) **Abrégé/Abstract:**

A container has a lid that can be opened only by lifting and pulling a pull tab, with lifting of the pull tab resulting in an evident change. The pull tab is held down by attachment (interference fit, weld, glue) to a lid surface by a hold-down that is joined to the pull tab by a pair of bridges. When the pull tab is lifted, the bridges are broken. Thereafter, the pull tab springs up slightly from the lid plane, under the force of one or more spring walls and a hinge, which makes it evident that the container has been opened.

ABSTRACT OF THE DISCLOSURE

A container has a lid that can be opened only by lifting and pulling a pull tab, with lifting of the pull tab resulting in an evident change. The pull tab is held down by attachment (interference fit, weld, glue) to a lid surface by a hold-down that is joined to the pull tab by a pair of bridges. When the pull tab is lifted, the bridges are broken. Thereafter, the pull tab springs up slightly from the lid plane, under the force of one or more spring walls and a hinge, which makes it evident that the container has been opened.

CONTAINERS WITH TAMPER-EVIDENT FEATURES

BACKGROUND

[0001] Consumer products and especially food, such as salads or grapes, is often sold in plastic containers, wherein a clerk at a store (who observes cleanliness standards) loads fresh food into a container and then closes it. Some customers are concerned that a person might have secretly opened the container to see if he/she likes the food, and then closed the container, leaving germs behind. Customers are assured of the integrity of the packaged food by constructing the container so if the container has been opened after the clerk loaded food into it, this fact will be evident. A container that was easy to open and reclose, and that indicated if it had been opened after the first time that it had been closed, and which could be constructed at low cost to produce a sturdy container, would be of value.

SUMMARY

[0002] Containers with tamper-evident features enables users to determine whether tampering has taken place on a container that has been filled with a product and sealed with a lid.

[0003] According to one aspect, there is described a container that has a vertical axis and that includes a base for holding goods and a lid with a main lid part that covers the base and with a pull-tab assembly that includes a pull-tab that is pivotally connected about a hinge axis to the main lid part to allow the pull-tab to pivot between a stowed position wherein the pull-tab lies over the main lid part and a deployed position wherein the pulltab extends at an angle of a plurality of degrees from said stowed position, wherein: in said stowed position, said pull-tab is fixed by a breakable joint to said main lid part; said pull-tab has a spring wall that is resiliently deformed when said pull-tab is forced downward to said stowed position and fixed by said breakable joint to said main lid part, so when said breakable joint is broken the pull-tab springs up to a raised position; said pull-tab assembly includes a holddown that is attachable to said main lid part; said spring wall includes a pair of raised portions on opposite sides of said breakable joint, and a pair of bridge surfaces extending from said pair of raised portions to said breakable joint, said pair of bridge surfaces being bent to extend at a downward incline when said pull-tab is forced downward to said stowed position.

[0004] According to another aspect, the pull-tab assembly may be defined as including a stowed position in which the holddown is attached to the lid and the pull tab is attached to the holddown, and a redeployed position in which the holddown is attached to the lid and the pull tab is detached from the holddown. To indicate tampering, the pull tab is prevented from being reattached to the holddown when in the redeployed position.

[0004a] There is also described a container with tamper-evident features, the container comprising: a base; a lid engageable with the base; and a pull-tab assembly disposed on the lid and including: a holddown; and a pull-tab connected by a breakable joint to the holddown; a living hinge by which the pull-tab assembly is attached to the lid at a periphery of the lid; the pull-tab assembly including: a stowed position in which the pull-tab assembly has been rotated about the living hinge from an initial deployed position to the stowed position, the lid is engaged with the base, the holddown is attached to the lid, the pull-tab is attached to the holddown, and biasing means urge the pull-tab away from the lid; and a redeployed position in which the lid is disengageable from the base, the holddown is attached to the lid, and the pull-tab is detached from the holddown by breaking of the breakable joint; the pull-tab assembly being configured such that: when being placed in the redeployed position from the stowed position by pulling the pull-tab away from the holddown, the pull-tab pivots with respect to the holddown and detaches from the holddown by the breaking of the breakable joint while the holddown remains attached to the lid; and, when in the redeployed position, the pull-tab is not reattachable to the holddown by virtue of the breakable joint being broken, thereby providing evidence of tampering, wherein the lid is not disengageable from the base when the pull-tab assembly is in the stowed position without pivoting the pull-tab assembly to the redeployed position.

[0005] Other features and advantages will become apparent to those skilled in the art from a consideration of the following detailed description taken in conjunction with the accompanying drawings.

DESCRIPTION OF THE DRAWINGS

[0006] FIG. 1 is a top isometric view of a container of the invention, shown closed and with the pull tab in an initial stowed configuration, prior to a first opening by a customer.

[0007] FIG. 2 is a view similar to that of FIG. 1, with the pull tab in an initial deployed position, as initially manufactured, and ready to be closed the first time, on the main lid part.

[0008] FIG. 3 is a partial isometric view of the lid of FIG. 2, with the pull tab in its initially deployed position and prior to the first time it is closed by a store clerk and then opened by a customer.

[0009] FIG. 4 is a partial isometric view of the area shown in FIG. 3, but with the pull tab in its initial stowed position, which it assumes prior to the first time the pull tab is opened by a customer.

[0010] FIG. 5 is an isometric view of the area of FIG. 4, but with the pull tab in its re-stowed and evident-opened position, which it assumes the first time the pull tab is opened by a customer and then closed by the customer, showing how the tab indicates the fact that the container has been opened by a customer.

[0011] FIG. 5A is a simplified sectional view of the pull tab region of the container, showing it in two positions.

[0012] FIG. 5B is a view taken on line 5B-5B of FIG. 4, showing the pull tab periphery and bridge surface.

[0013] FIG. 5C through FIG. 5E are views taken on line 5D-5D of FIG. 6, showing the pull tab as it is being installed in the holddown, showing the pull tab as it appears when fully installed in the holddown by a store clerk, and showing the pull tab as it appears after the bridges have been broken by a customer.

[0014] FIG. 6 is a sectional view of a portion of the container of FIG. 4, in its initial stowed position and prior to an opening by a customer.

[0015] FIG. 7 is a top isometric view of a portion of a container of another embodiment of the invention, as manufactured and in its initial deployed position.

[0016] FIG. 8 is a view similar to FIG. 7, but showing the container after the pull tab has been moved to an initial stowed position and when the tip region has been partially lifted.

[0017] FIG. 9 is a view similar to FIG. 8, after the tip region has been lifted by a customer.

[0018] FIG. 10 is an isometric sectional view of the pull tab of FIG. 8 taken on line 10–10 of FIG. 8, prior to opening the container.

[0019] FIG. 11 is an isometric sectional view of the pull tab of FIG. 8, taken on line 11–11 of FIG. 8, when the tip region has been partially lifted.

[0020] FIG. 12 is a partial isometric view of a portion of a rectangular container with a pull-tab assembly in the initial deployed position.

[0021] FIG. 13 is an isometric view of the embodiment of FIG. 12 with the pull tab in the initial stowed position.

[0022] FIG. 14 is a partial isometric view of a container of another embodiment of the invention wherein the pull tab is designed to be bonded to the main lid portion and the pull tab is in its initial deployed position.

[0023] FIG. 15 is a view similar to that of FIG. 14, but with the pull tab in an initial stowed position.

DETAILED DESCRIPTION

[0024] FIG. 1 shows a container 10 of the invention which includes a base 12 that has a lower portion 14 that holds food or other articles or material, and that has an upper rim 16. The container also includes a lid 20 which closes an opening 17 (FIG. 2) at the top of the base. The lid and/or the base is formed of an easily deformable molded plastic, so the lid can be pulled forcefully out of the base, despite a lid flange 22 whose perimeter is concealed by the base. The base and lid lie on a vertical axis 24.

[0025] The lid includes a pull-tab assembly 26 that includes a holddown 40 and a pull tab 30. FIG. 2 shows the container as it is manufactured. The manufacturer ships the container with the pull-tab assembly 26 in the initial deployed position of FIG. 2 wherein the pull tab 30 has been

pivoted by an angle J (FIG. 5) of more than 12° away from the initial stowed position of FIG. 1. In FIG. 2 the pull tab (as manufactured) is angled 180° from the initial stowed position of FIG. 1, so in FIG. 2 the pull tab 30 extends radially outward (away from axis 24) from its hinge axis 32. At a store or food distributor, a clerk loads the base with food and then moves the pull tab 30 to the initial stowed position of FIG. 1 wherein the pull tab 30 extends radially inward toward the hinge axis and at an angle J of less than 12° to the horizontal (usually less than 6°). Movement to the stowed position is done by a store clerk, by pivoting the pull-tab assembly 26 about a hinge pivot axis 32 (FIG. 2) from the initial deployed position shown in FIG. 2 to an initial stowed position shown in FIG. 1. In FIG. 2 the pull-tab assembly 26 projects from a circular periphery main lid portion 36.

[0026] The lid flange 22 is hidden because it lies in a groove 33 of the base, and the lid is removed by pulling up the pull tab. In the redeployed position of FIG. 5, the pull-tab assembly 26 can be pulled up to pull the lid 20 out of the base and thereby provide access to a base cavity 35 (FIG. 2) in the lower base portion 14. Afterwards, the pull-tab assembly 26 can be pivoted back toward the stowed position of FIG. 1 but not completely to the stowed position of FIG. 1. Once a customer pulls the pull tab to pivot it more than 12° toward the deployed position of FIG. 2, and then pivots the pull tab toward the stowed position of FIG. 1, it becomes evident that the container has been opened. This provides assurance to customers that if the pull-tab assembly appears to never have been opened, it has not been opened (after the store clerk first loaded food into it and closed the lid).

[0027] FIG. 3 shows details of the pull-tab assembly 26, in its configuration as manufactured. The pull-tab assembly 26 includes a pull tab 30 joined by a hinge 34 to an edge portion 37 of the lid main portion to pivot about the hinge axis 32. The pull-tab assembly also has a holddown portion or holddown 40 that is connected at 43 to the main lid portion 36. The location 43 lies within $\frac{1}{2}$ inch and preferably within $\frac{1}{4}$ inch of the hinge axis 32. The lid has a tab mount surface 42. The pull tab lies facewise against the mount surface 42 before a customer lifts the pull tab, and the pull tab lies directly above (at an angle J of at least 12° from the mount surface 42) when the container is reclosed. The pull tab is connected by a breakable joint in the form of a pair of bridges such as 54 to the holddown 30. The holddown 40 includes a lock projection 44 that fits into a lock recess 46 in the lid. The lock parts 44, 46 lie in series with the

bridges so breaking the bridges allows the pull tab to be lifted while the lock parts remain locked together. The holddown also includes a thin sheet portion **50** of plastic on which the lock projection **44** is initially formed. When the pull tab **30** is initially pivoted closed (stowed) on the lid as by a store clerk, to the position shown in FIG. 4, the lock projection **44** fits into the lock recess **46** and locks in position therein. The locking occurs due to an interference fit resulting from the lock recess and projection being undercut. Thereafter, the only way to release the pull tab **30** is to break a pair of bridges **52, 54** that join the pull tab **30** to the holddown **40**. The pull tab is partially separated from the holddown by a through slot **85** that is interrupted by the bridges **52, 54** and the connection **43**.

[0028] When a customer wants to open the container after food has been loaded in by a store clerk and the lid **20** has been closed, the customer inserts a finger (e.g., the index finger) into a finger recess **60** (FIG. 4) so the person's finger lies under a tip part **62** of the pull tab **30**. The person then pries up the tip part to pry up the pull tab **30** and break the bridges **52, 54**. This separates the pull tab **30** from the holddown **40** (except at the holddown end **40e** that lies adjacent to the hinge **34**). The holddown **40** remains locked through the lock projection **44** and lock recess **46** to the main circular portion **36** of the lid. A customer can pull up the pull tab **30** to lift the lid off the base. The pull tab is formed with a recess **48** (FIG. 3) that lies adjacent to the tip **62**. The recess **48** stiffens the end of the pull tab and makes it easier to tightly hold the pull tab without slipping.

[0029] When a customer again closes the container, and pivots the pull tab **30** back toward its original position of FIG. 1, the pull tab surface **65** (FIG. 3) does not lie "flat" against a lid surface **38** (FIG. 3), but springs up slightly as to the position shown at **30B** in FIG. 5. Two major phenomena keep the pull tab in a raised position such as in FIG. 5. These phenomena include the hinge **34** (FIG. 3) and the resilience of spring walls **80, 81** (FIG. 4). The resilience of the spring walls **80, 81** results in the pull tab moving upward (above the lid main portion **36** in FIG. 4) when the bridges **52, 54** are broken, while the holddown **40** does not move upward, so the pull tab **30** lies above the holddown.

[0030] The hinge **34** (FIG. 3) by which the pull tab **30** is connected to the lid does not tend to remain in the 180° folded position of FIG. 1, but tends to straighten by a plurality of degrees, preferably at least 6° and more preferably at least 12°, so the pull tab pivots up and is angled J by

a plurality of degrees from a flat position, as shown in FIG. 5. After the bridges 52, 54 are broken, the holddown 40 is connected to the pull tab 30 only through the connection 43 (FIG. 3), which is close to the hinge axis 32 and therefore has little effect upon the position of the pull tab. The resilience of the hinge therefore urges the pull tab to pivot upward.

[0031] A plurality of spring walls, including walls 80, 81 (FIG. 4) raise the pull tab toward the raised position of FIG. 5. Applicant constructs the pull tab 30 (FIG. 4) with a raised periphery 70 (FIG. 4). The raised periphery 70 is supported on largely vertical inclined walls 72 extending at upward inclines from the pull tab bridge surface 74 (that connects to the bridges 52, 54) to the raised periphery 70. This stiffens the pull tab 30 against bending. The raised periphery 70 also has a pair of stiffening ridges 76 to resist bending. Thus, when the pull tab 30 is broken free of the holddown 40, except at the hinge 34, the pull tab 30 is a stiff member. Applicant notes that the pull tab 30 is symmetric about a radial line 78.

[0032] The raised periphery 70 (FIG. 4) connects through a radially-inward (toward axis 24) and downward inclined spring wall 80 to pull tab surface portions 61, 63. The pull-tab assembly is constructed so the spring wall 80 tends to raise the periphery 70 and the tab surface, although the bridge surface is initially held down through the bridges 52, 54 to the holddown 40. However, when the bridges 52, 54 are first broken, which occurs when a customer forcefully lifts the tip part 62, the spring wall 80 lifts the periphery 70 and the bridge surface 74. The tab surface 61 then lies above the holddown 40, and this is very apparent to customers.

[0033] FIG. 5A shows that when the manufacturer first pivots the pull tab to the stowed position, the manufacturer pushes down the raised periphery from 70A to 70 so its angle from the horizontal moves from B to A. The pull tab is held in this position by the holddown 40 (FIG. 4). In this position the spring walls 80, 81 have been deflected toward the horizontal. When the pull tab is thereafter raised and the bridges 52, 54 to the holddown are broken, the pull tab will not return to the original factory position. Instead, the periphery 70 will rise to position 70A as the spring walls 80, 81 return toward more vertical positions 80A, 81A.

[0034] FIG. 5B is a view taken along line 5B-5B of FIG. 4, showing the pull-tab assembly 26 as a store clerk is depressing it. The pull-tab assembly is pressed down until the projection 44 is pressed into the undercut recess 46. During such pressing, the store clerk depresses the raised

periphery **70** to position **70B**, while also depressing the bridge surface **74**. Afterward, the periphery tends to spring up to position **70B**.

[0035] FIG. **5C** is a view taken on line **5D–5D** of FIG. **6**, showing the raised periphery **70** that lies on circumferentially opposite sides of a radial line **78**, which is also shown in FIG. **4**. FIG. **50** shows that opposite bridge surfaces **74** and the inclined walls **72** are also depressed and bent by the store clerk during initial installation. As the projection **44** is forced into the recess **46** to initially close, or stow, the pull tab, the bridge surfaces **74** are downwardly bent to depress the holddown **40**. The bent bridge surfaces **74** are maintained in the downward bent configuration until a customer lifts the tip part **62** (FIG. **58**) and breaks the bridges **52**, **54**. FIG. **5E** shows that a person can see a gap between the holddown **40** and the bridge surface **74** of the pull tab after the bridges have been broken.

[0036] The pull tab is held to the main lid part through a breakable joint which includes the lock projection **44** (FIG. **3**) that lies in an interference fit in the lock recess **46** and which is not a breakable part. The pull tab also includes the bridges **52**, **54** that are breakable. Together they form a breakable joint.

[0037] Instead of using a lock projection **44** (FIG. **3**) and lock recess **46** to initially hold the pull tab in the initial stowed position as supplied by the manufacturer, other holddown means can be used. It is possible to use a bonded joint, formed by a weld or adhesive, to fasten the holddown **40** to the lid main portion at **36** (FIG. **3**) and use that as a breakable joint instead of the bridges **52**, **54**. In any case, it is desirable to lock the pull tab to lid main portion at **36** with the pull tab pressed downward against the mount surface **42**, so the spring walls **80**, **81** (FIG. **4**) are deflected towards the horizontal and tend to spring back to be more vertical.

[0038] FIG. **6** is a view similar to FIG. **5A**, and shows a cross-section of the container taken through the raised periphery **70**. Applicant notes that the rim of the base and lid form a convex seal **51** on the lid that abuts a concave seal **53** formed by the base. The base forms a radially inward-opening recess **47** that receives the hinge **34** that is formed by the lid. Walls of the recess **47** form an overhang **58** that deters tampering.

[0039] FIG. **7** shows another embodiment of the invention, wherein a pull-tab assembly **110** has a spring wall **112** that raises the pull tab **114** after a first opening. The pull-tab assembly **110**

includes a hinge **120** that connects to a pull tab **114**. At a factory, the pull-tab assembly **110** is pivoted about hinge **120** to a closed, or stowed position wherein the pull tab **114** lies over the lid main portion **121** at an angle of less than 12° (preferably less than 6°) to the lid main portion surface. FIG. **8** shows the pull-tab assembly **110** in the initial stowed position to which a store clerk has positioned the pull tab, except that a customer has then inserted his finger into the finger hole **122** and lifted the tip **124** of the pull tab. When the tip **124** has been lifted, a tip region **130** of the pull tab pivots about a pivot axis **132**. The pull tab is scored along the axis **132** to weaken it at locations **142**, **144** to pivot thereat, and is cut through along curved line **146** to form a radially outward projection of the spring wall **112**. When the tip inner end region **130** is pivoted up (e.g., over 6°) by a customer to the raised position of FIG. **8**, the spring wall projection **112** lifts the pull tab **110** and breaks a bridge **134**. The next time a customer moves the pull tab to the restowed position, the spring wall **112** prevents the pull tab from lying "flat" so the pull tab is raised (preferably by at least 12°).

[0040] The pull tab inner end, or tip region **130** is connected through bridge **134** to a flat holddown **160**. When pull tab region **130** is lifted, it breaks the bridge **134**. After the bridge is broken, the spring wall **112** keeps the pull tab lifted as shown in FIG. **9**, with the spring wall **112** pressing against the lid main portion **162** and with the tip region **130** being raised.

[0041] FIG. **8** shows that the holddown **160** has a stiffening rib **168** at the radially outer end portion **40e** of the holddown. The rib **168** prevents the holddown end portion **40e** from bending up to place the radially inner end **40i** of the holddown at the same level as the bridge surface **74** when a customer has not opened the container and restowed the pull tab.

[0042] FIGS. **12** and **13** show a pull-tab assembly **150** of a rectangular container **152** (with a vertical axis, not shown). In this container, the undercut lock recess **154** lies in the pull tab **174** and the projection **156** lies on the main lid portion **160**. A holddown **162** on the pull-tab assembly **150** is joined by bridges **170**, **172** to the pull tab **174**.

[0043] FIGS. **14** and **15** show another pull-tab assembly **200** mounted on a main lid portion **202** of a lid **204**. The pull-tab assembly includes a holddown **210** joined by bridges **212** to the pull tab **214**. However, the holddown **210** is not joined by a projection and recess to the main lid portion **202**, but is joined by a bonded connection. In FIG. **14** the bonded connection is a joining

of the regions **222**, **224** by adhesive **226**. FIG. **15** shows a bonded connection made by welding **230**. Welding usually comprises sonic welding although heat welding can be used.

[0044] Although particular embodiments of the invention have been described and illustrated herein, it is recognized that modifications and variations may readily occur to those skilled in the art, and consequently, it is intended that the claims be interpreted to cover such modifications and equivalents.

THE EMBODIMENTS OF THE INVENTION IN WHICH AN EXCLUSIVE PROPERTY OR PRIVILEGE IS CLAIMED ARE DEFINED AS FOLLOWS;

1. A container that has a vertical axis and that includes a base for holding goods and a lid with a main lid part that covers the base and with a pull-tab assembly that includes a pull-tab that is pivotally connected about a hinge axis to the main lid part to allow the pull-tab to pivot between a stowed position wherein the pull-tab lies over the main lid part and a deployed position wherein the pulltab extends at an angle of a plurality of degrees from said stowed position, wherein:

in said stowed position, said pull-tab is fixed by a breakable joint to said main lid part; said pull-tab has a spring wall that is resiliently deformed when said pull-tab is forced downward to said stowed position and fixed by said breakable joint to said main lid part, so when said breakable joint is broken the pull-tab springs up to a raised position;

said pull-tab assembly includes a holddown that is attachable to said main lid part;

said spring wall includes a pair of raised portions on opposite sides of said breakable joint, and a pair of bridge surfaces extending from said pair of raised portions to said breakable joint, said pair of bridge surfaces being bent to extend at a downward incline when said pull-tab is forced downward to said stowed position.

2. The container of claim 1 wherein said pull-tab includes a stiffening ridge to resist bending.

3. The container of claim 1 wherein said lid includes a finger recess to provide access for a finger under a tip part to pull the pull-tab.

4. The container of claim 1 wherein said pull-tab includes a recess that lies adjacent to a pull-tab tip, said recess stiffening the end of the pull-tab.

5. The container of claim 1 wherein said pull-tab includes a lock projection and said main lid part includes a lock recess; said lock projection and said lock recess being engagable with an interference fit.

6. The container of claim 1 wherein said pull-tab and said holddown are partially separated by a through slot.

7. The container of claim 1 wherein said lid is engageable with the base and said pull-tab assembly is disposed on said lid, wherein:

said holddown is attachable to said main lid part of said lid; and

said pull-tab is pivotally attached to said lid and releasably attached to said holddown by said breakable joint, such that when said holddown is attached to said main lid part and said pull-tab is pulled away from said main lid part, the pull-tab is detached from the holddown by breaking said breakable joint while said holddown remains attached to said main lid part.

8. The container of claim 7 wherein when in said stowed position, said holddown is attached to said main lid part and said pull-tab is attached to said holddown, further comprising a redeployed position in which said holddown is attached to said main lid part and said pull-tab is detached from said holddown by breaking said breakable joint; and

wherein when in said redeployed position, said pull-tab is not reattachable to said holddown.

9. The container of claim 8 wherein said lid is not disengageable from said base when said pull-tab assembly is in said stowed position without pivoting the pull-tab to the deployed position.

10. The container of claim 9 wherein when said pull-tab assembly is in said deployed position, said holddown is further detached from said main lid part and said pull-tab is attached to said holddown.

11. The container of claim 7 wherein said pull-tab assembly is configured such that when said pull-tab is detached from said holddown by breaking of said breakable joint, said pull-tab is biased upwardly by said spring wall and is prevented from lying against said main lid part.

12. The container of claim 7 wherein said pull-tab assembly further includes a hinge for pivotally attaching said pull-tab to said lid; said hinge being configured to cause said pull-tab to spring up from said main lid part when said pull-tab is detached from said holddown.

13. The container of claim 7 wherein said spring wall of said pull-tab assembly is further configured to cause said pull-tab to spring away from said main lid part to remain in said raised position when said pull-tab is detached from said holddown.

14. The container of claim 7 wherein said breakable joint is disposed between said pull-tab and said holddown for releasably attaching said pull-tab to said holddown.

15. The container of claim 14 wherein said breakable joint includes a bridge connecting said pull-tab to said holddown such that when said pull-tab is pulled away from said main lid part, said bridge breaks.

16. The container of claim 7 wherein said holddown is mechanically attached to said main lid part.

17. The container of claim 16 wherein said pull-tab assembly includes a lock projection disposed on said holddown and a lock recess disposed on said main-lid part for receiving said lock projection.

18. The container of claim 7 wherein said holddown is attached to said main lid part by bonding.

19. The container of claim 18 wherein said holddown is adhered to said main lid part.

20. The container of claim 18 wherein said holddown is welded to said main lid part.

21. A container with tamper-evident features, the container comprising:
a base;

a lid engageable with the base; and
 a pull-tab assembly disposed on the lid and including:
 a holddown; and
 a pull-tab connected by a breakable joint to the holddown;
 a living hinge by which the pull-tab assembly is attached to the lid at a periphery of the lid;

the pull-tab assembly including:
 a stowed position in which the pull-tab assembly has been rotated about the living hinge from an initial deployed position to the stowed position, the lid is engaged with the base, the holddown is attached to the lid, the pull-tab is attached to the holddown, and biasing means urge the pull-tab away from the lid; and
 a redeployed position in which the lid is disengageable from the base, the holddown is attached to the lid, and the pull-tab is detached from the holddown by breaking of the breakable joint;

the pull-tab assembly being configured such that:
 when being placed in the redeployed position from the stowed position by pulling the pull-tab away from the holddown, the pull-tab pivots with respect to the holddown and detaches from the holddown by the breaking of the breakable joint while the holddown remains attached to the lid; and,
 when in the redeployed position, the pull-tab is not reattachable to the holddown by virtue of the breakable joint being broken, thereby providing evidence of tampering,
 wherein the lid is not disengageable from the base when the pull-tab assembly is in the stowed position without pivoting the pull-tab assembly to the redeployed position.

22. The container of claim 21, wherein the biasing means comprise a spring wall configured to urge the pull-tab to move away from the lid when the pull-tab is detached from the holddown.

23. The container of claim 21 wherein the pull-tab assembly includes a lock projection disposed on the holddown and a lock recess disposed on the lid for receiving the lock projection.

24. The container of claim 21, wherein the lid and the base form a rounded container.
25. The container of claim 21, wherein the lid and the base have corners and form a square or rectangular container.
26. The container of claim 21, wherein the pull-tab assembly is attached to the lid at a weld spot.
27. The container of claim 21, wherein the lid further comprises a recess to allow a finger pulling of the tip of the pull-tab.
28. The container of claim 21, wherein the lid and the base are separate.

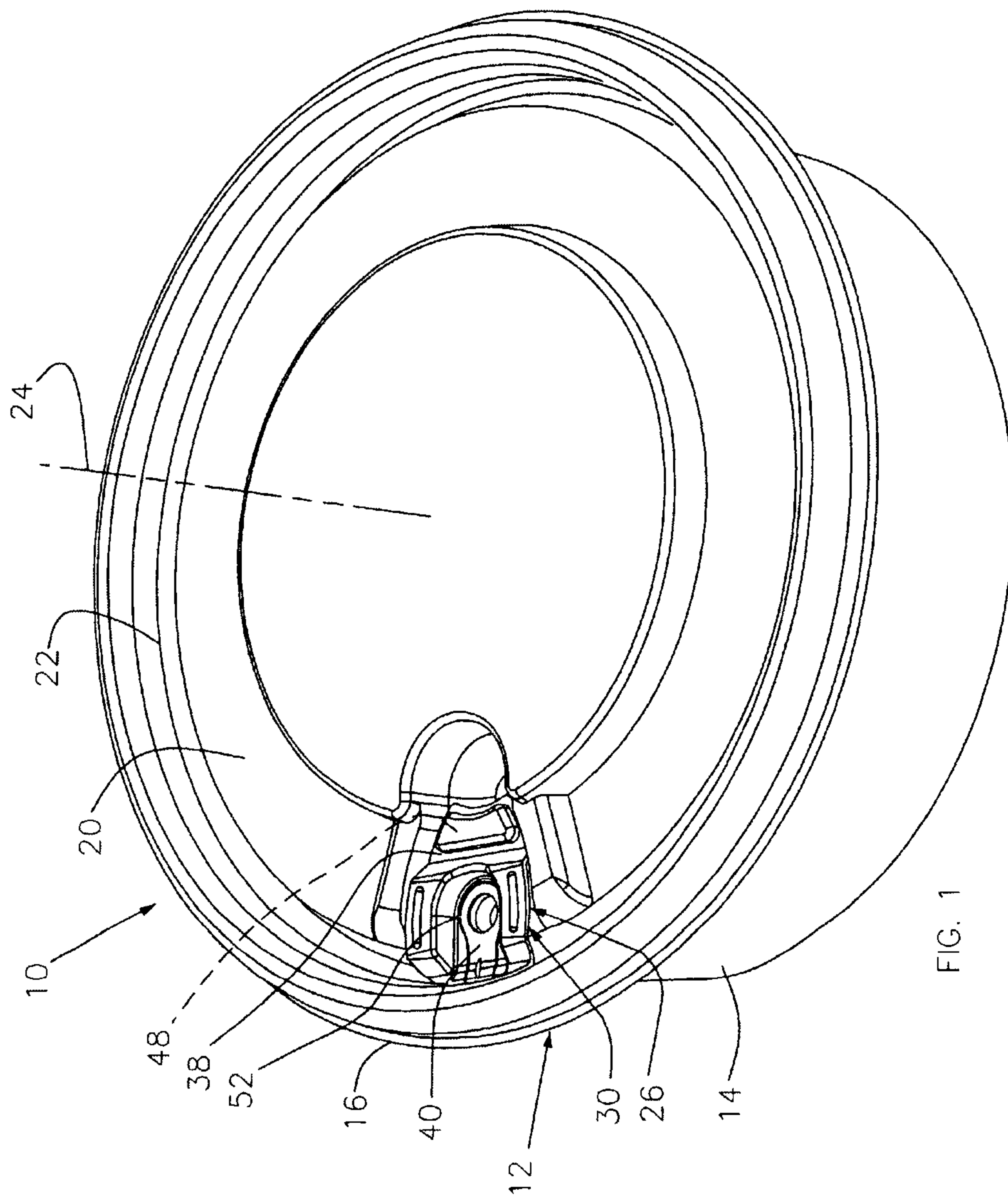

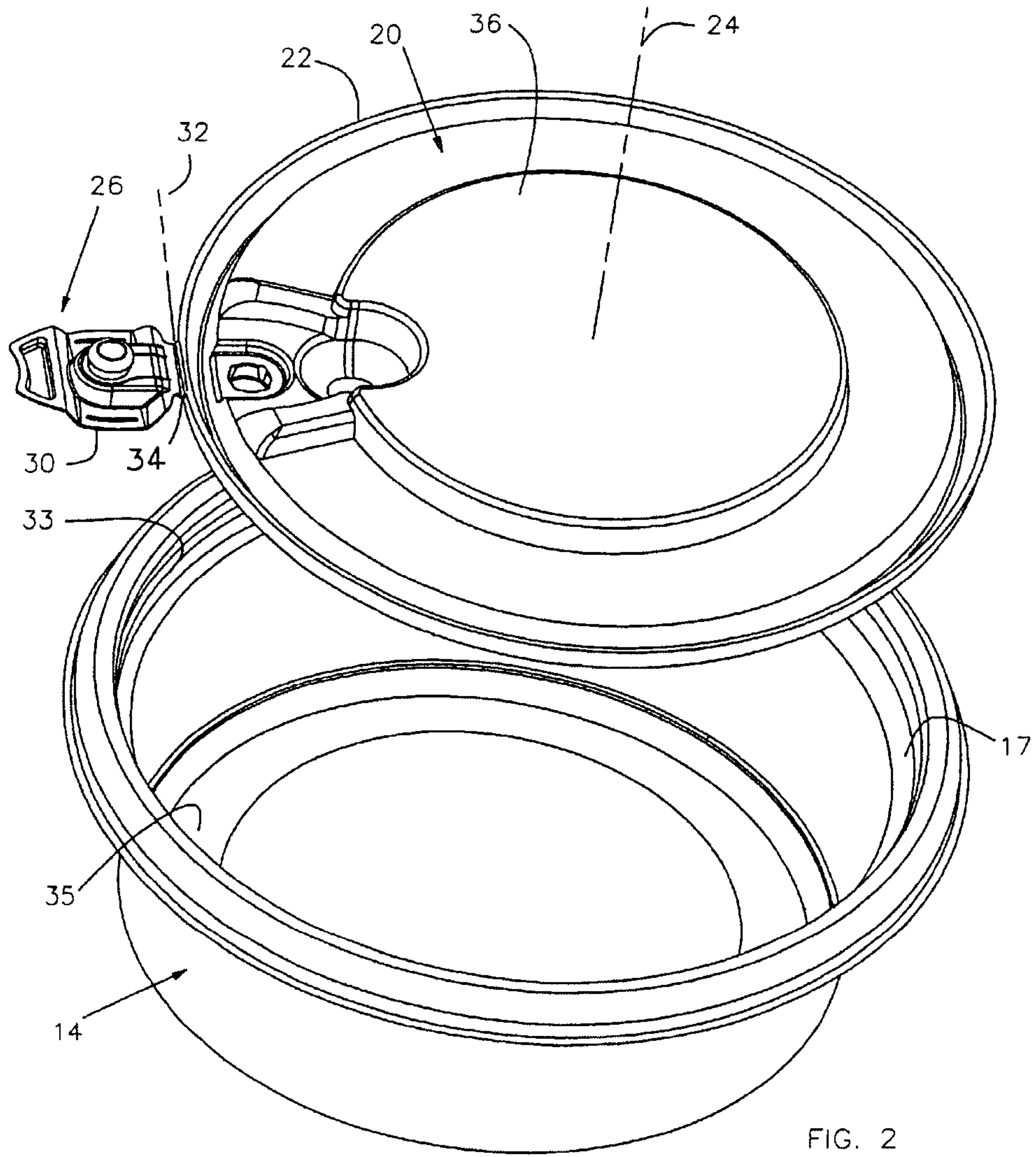

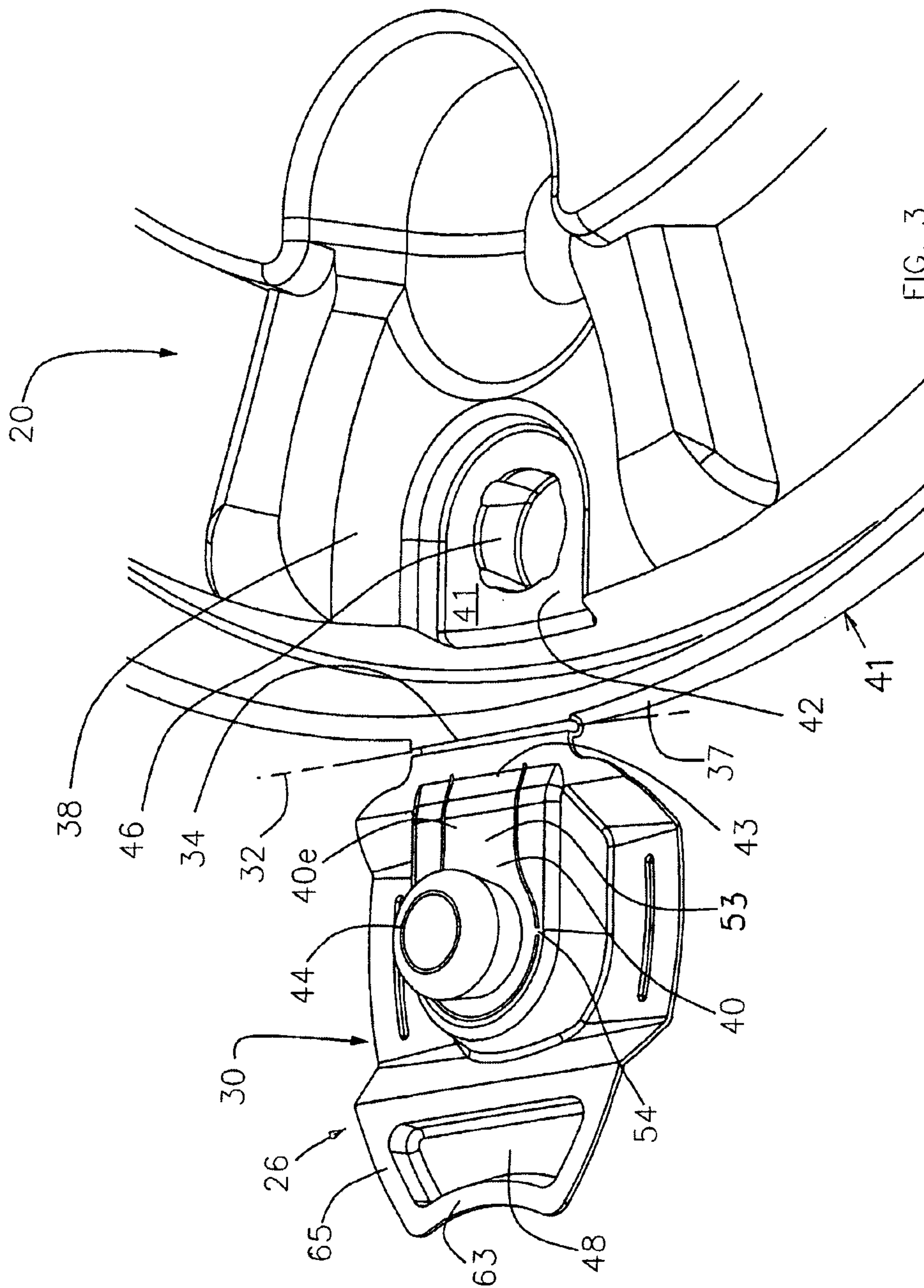

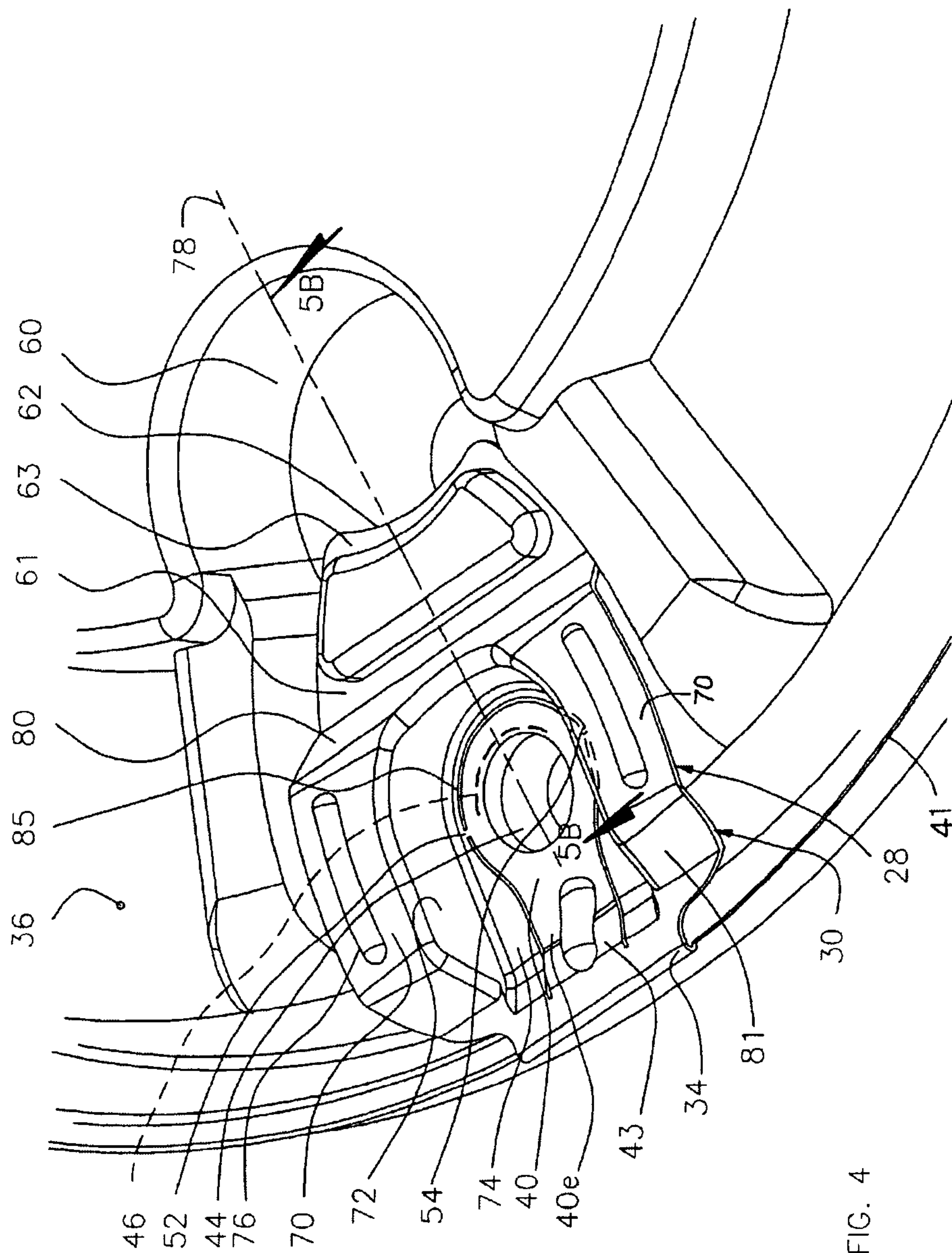
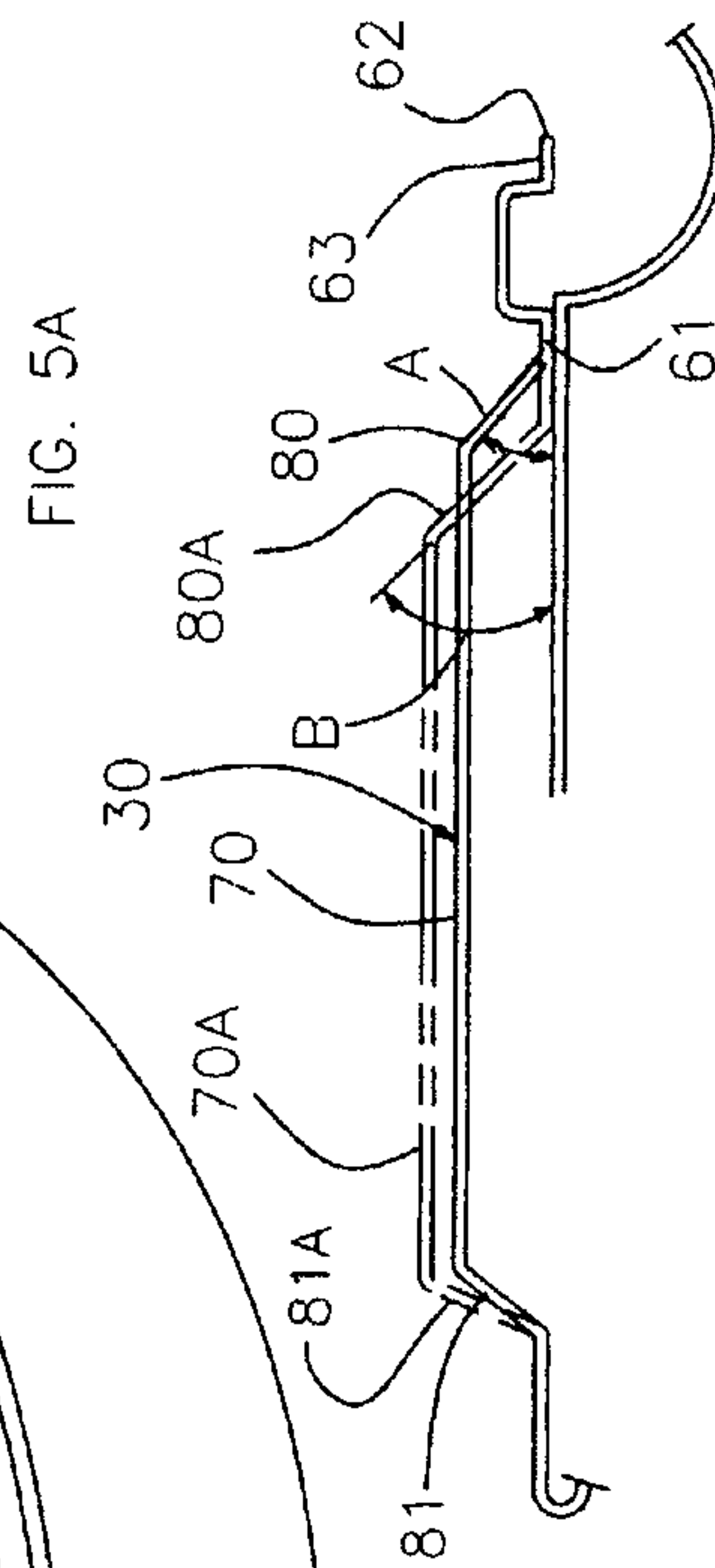
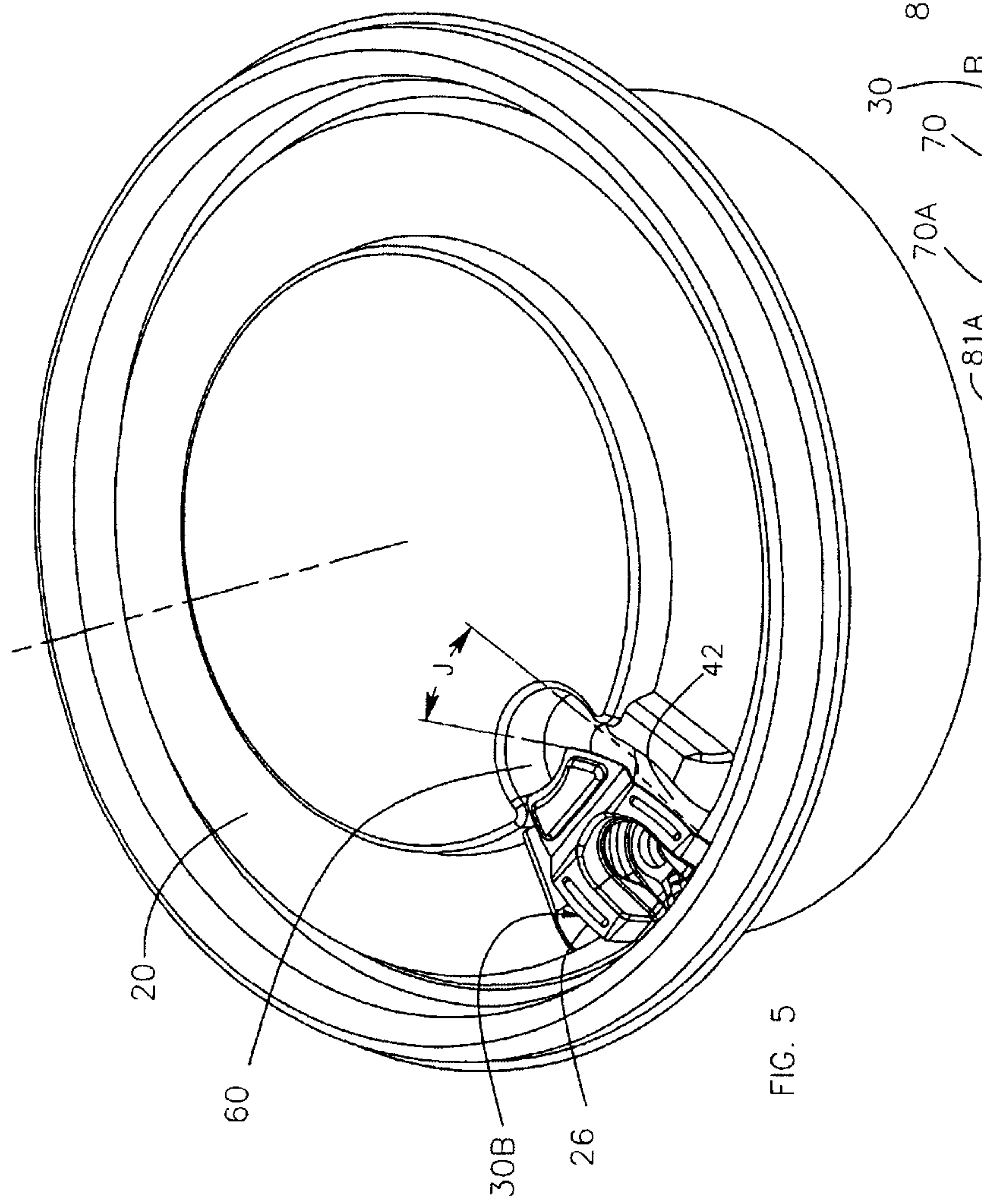

FIG. 4



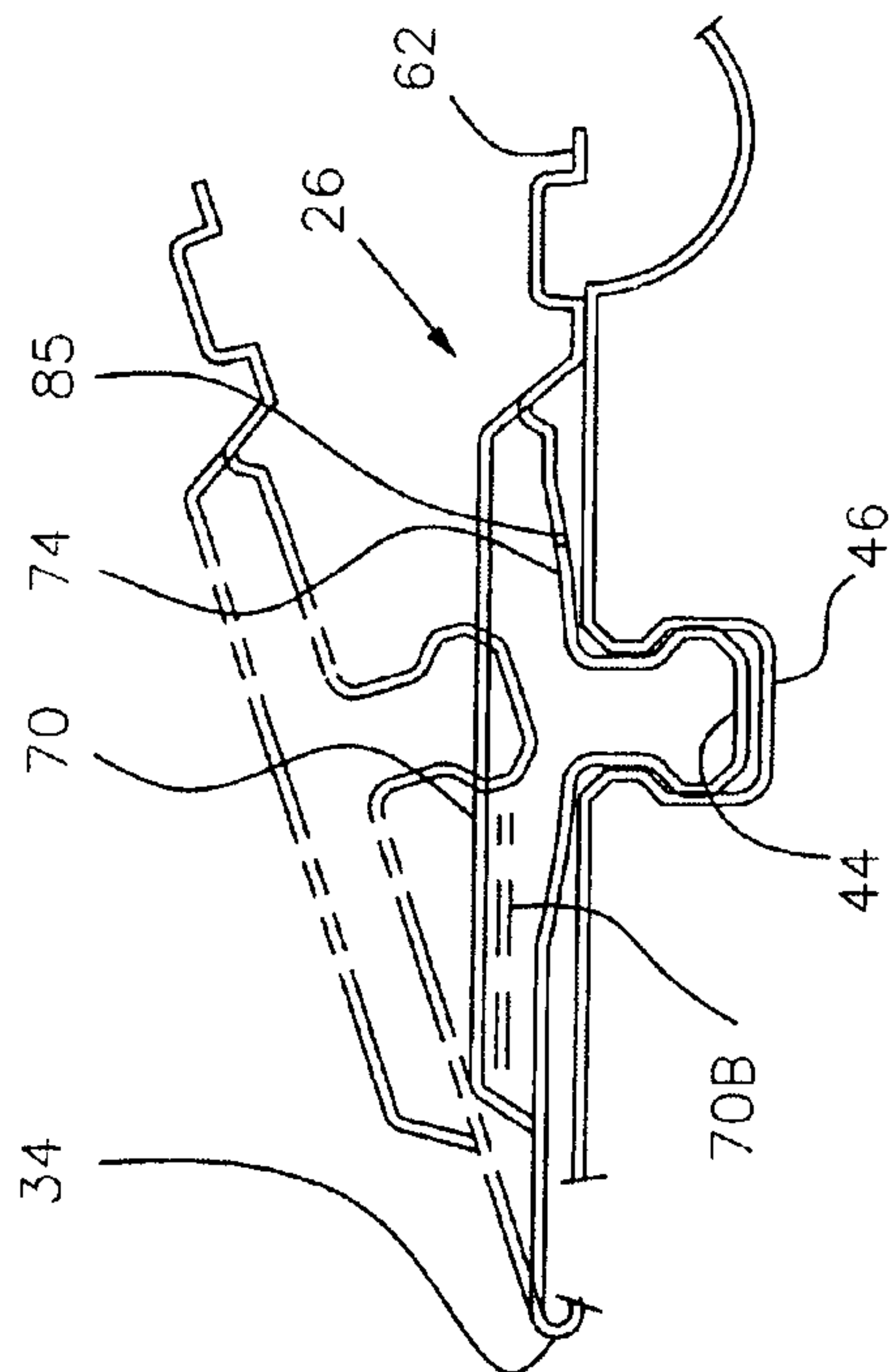
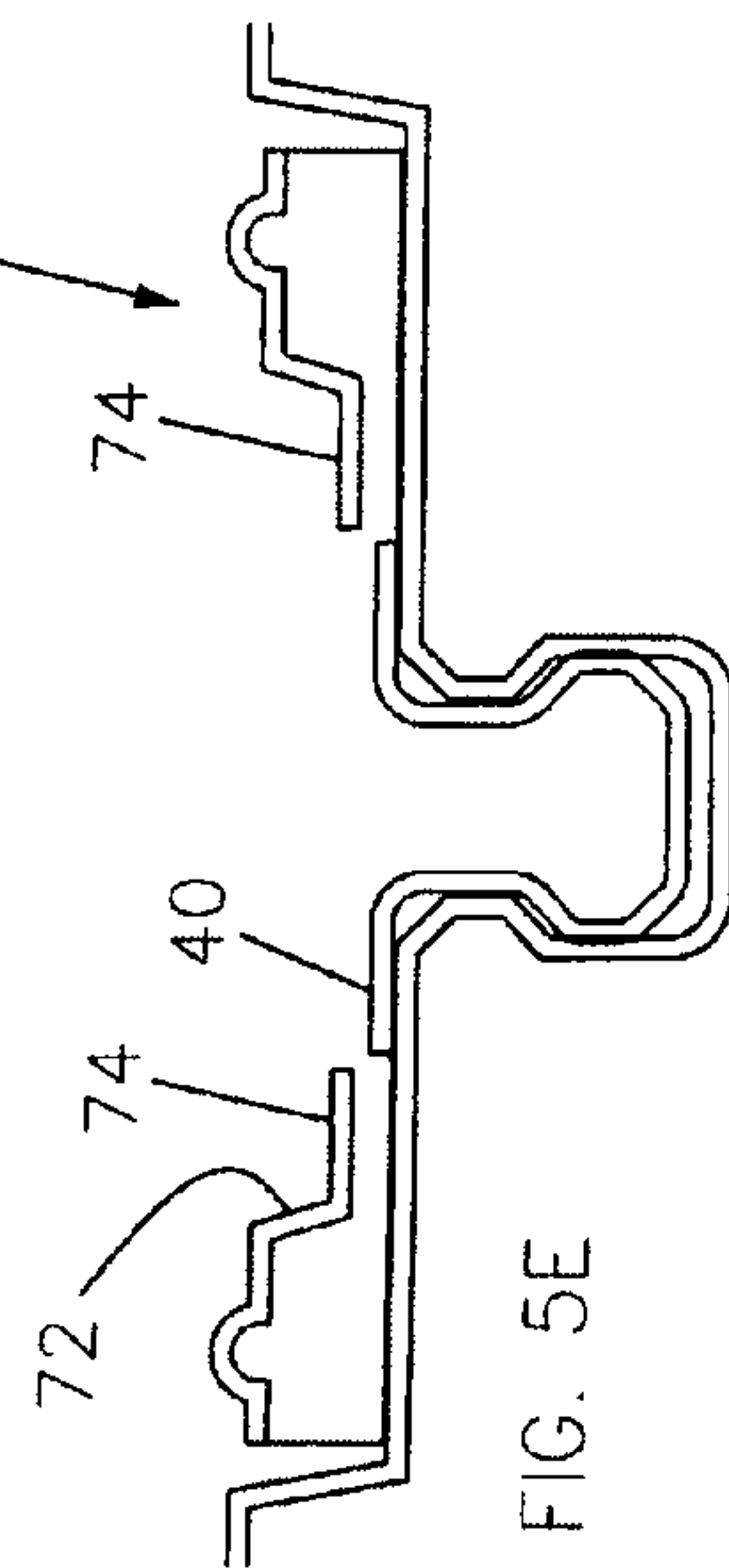
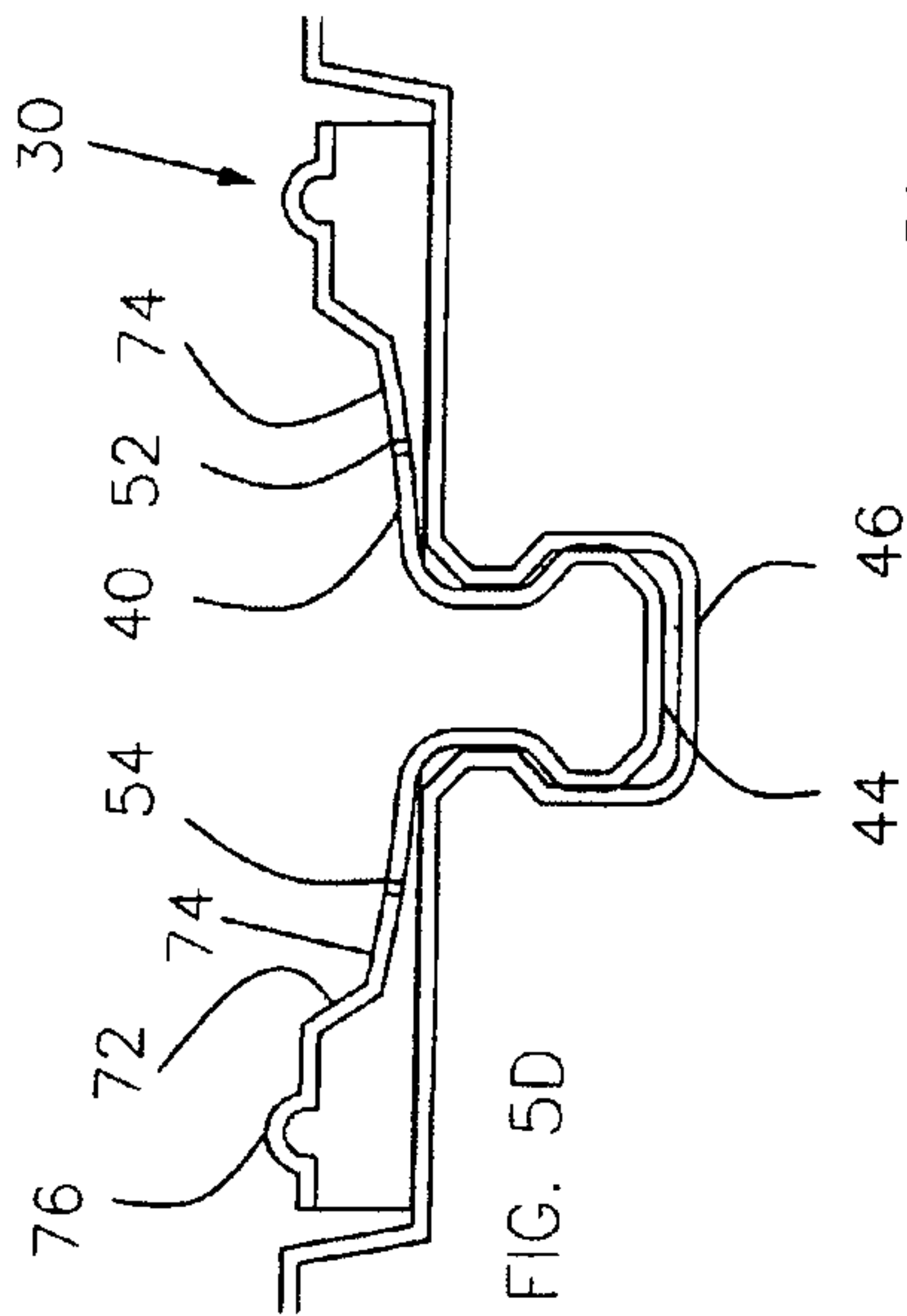
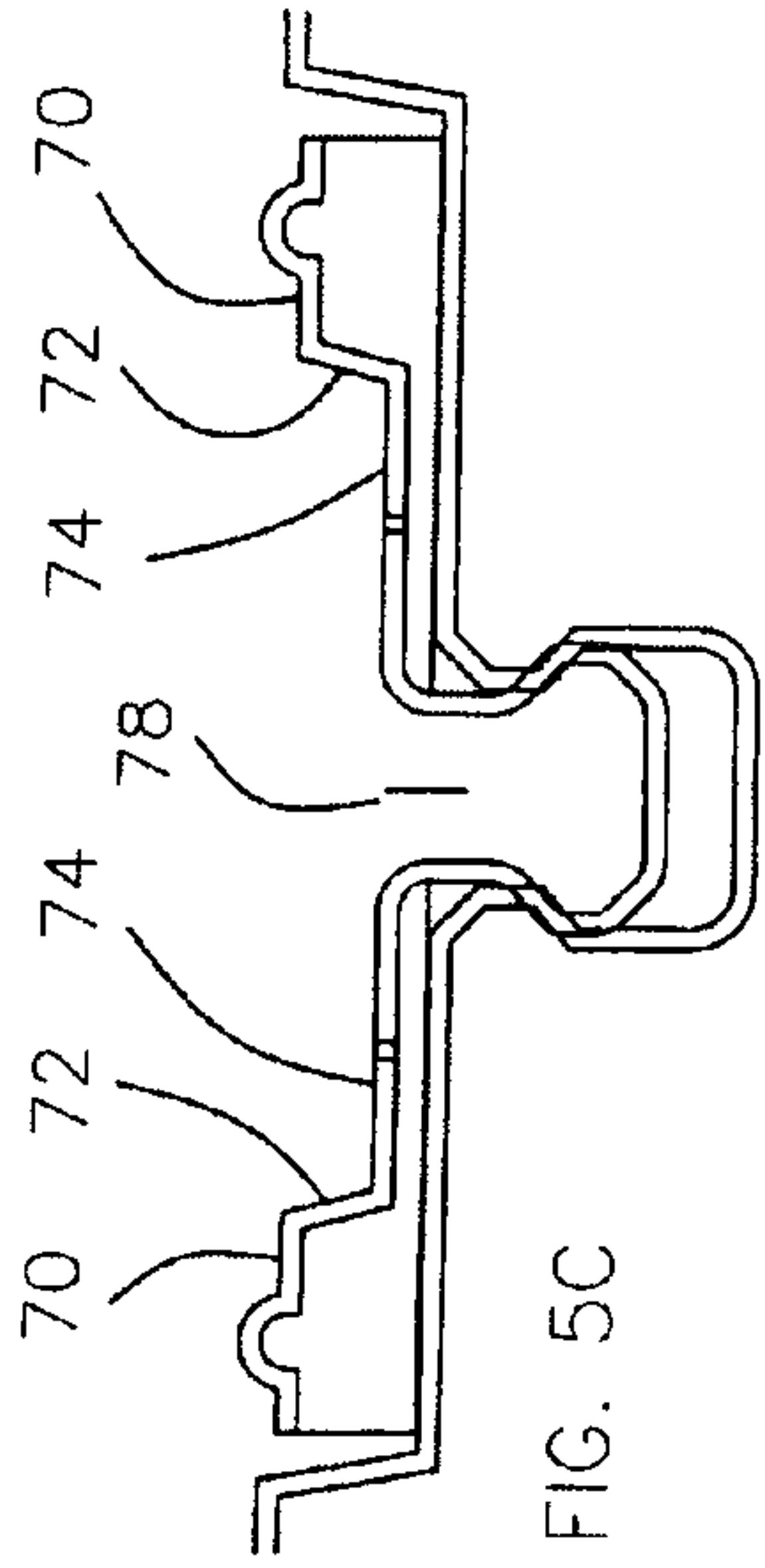
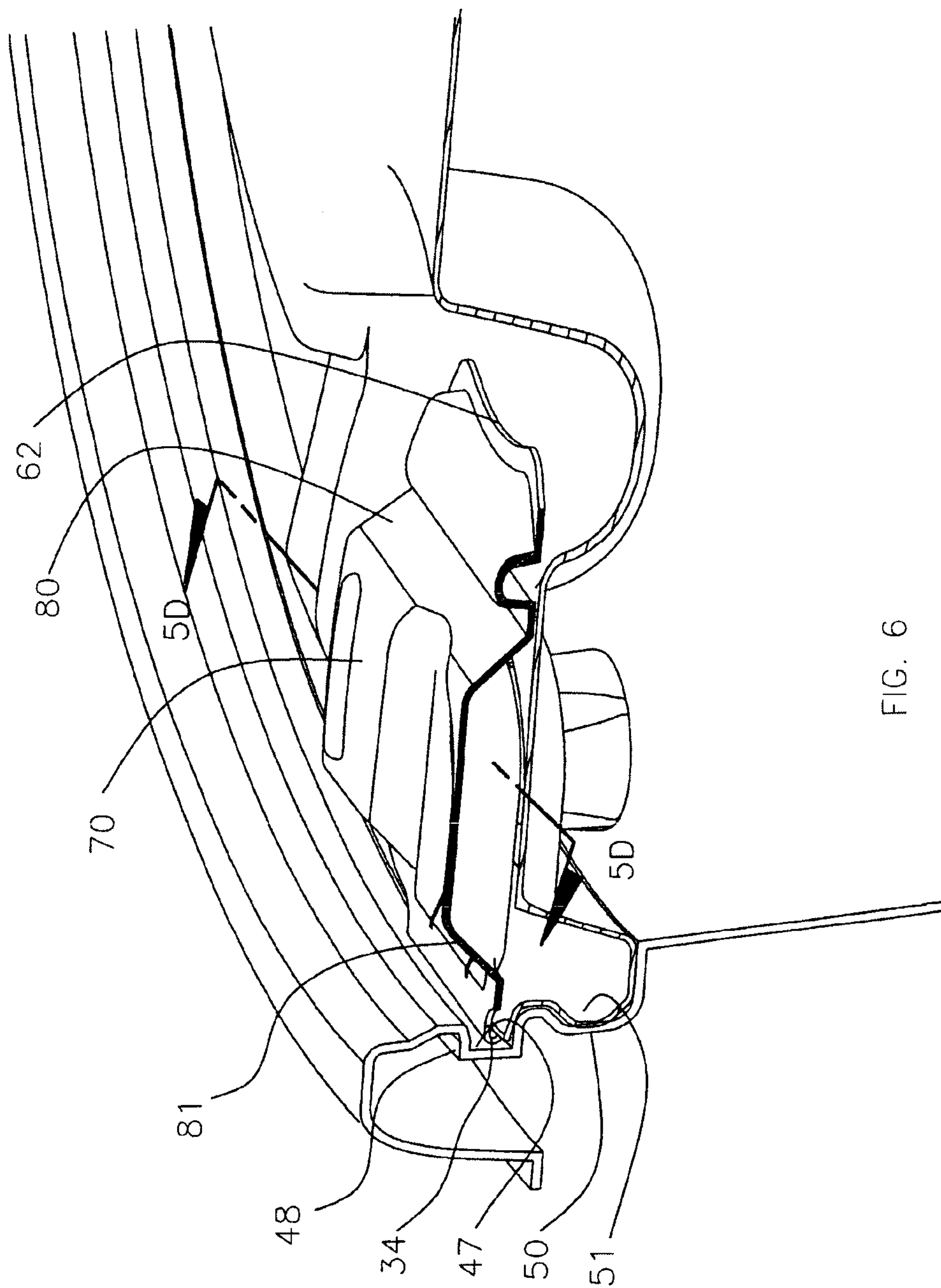

FIG. 5B



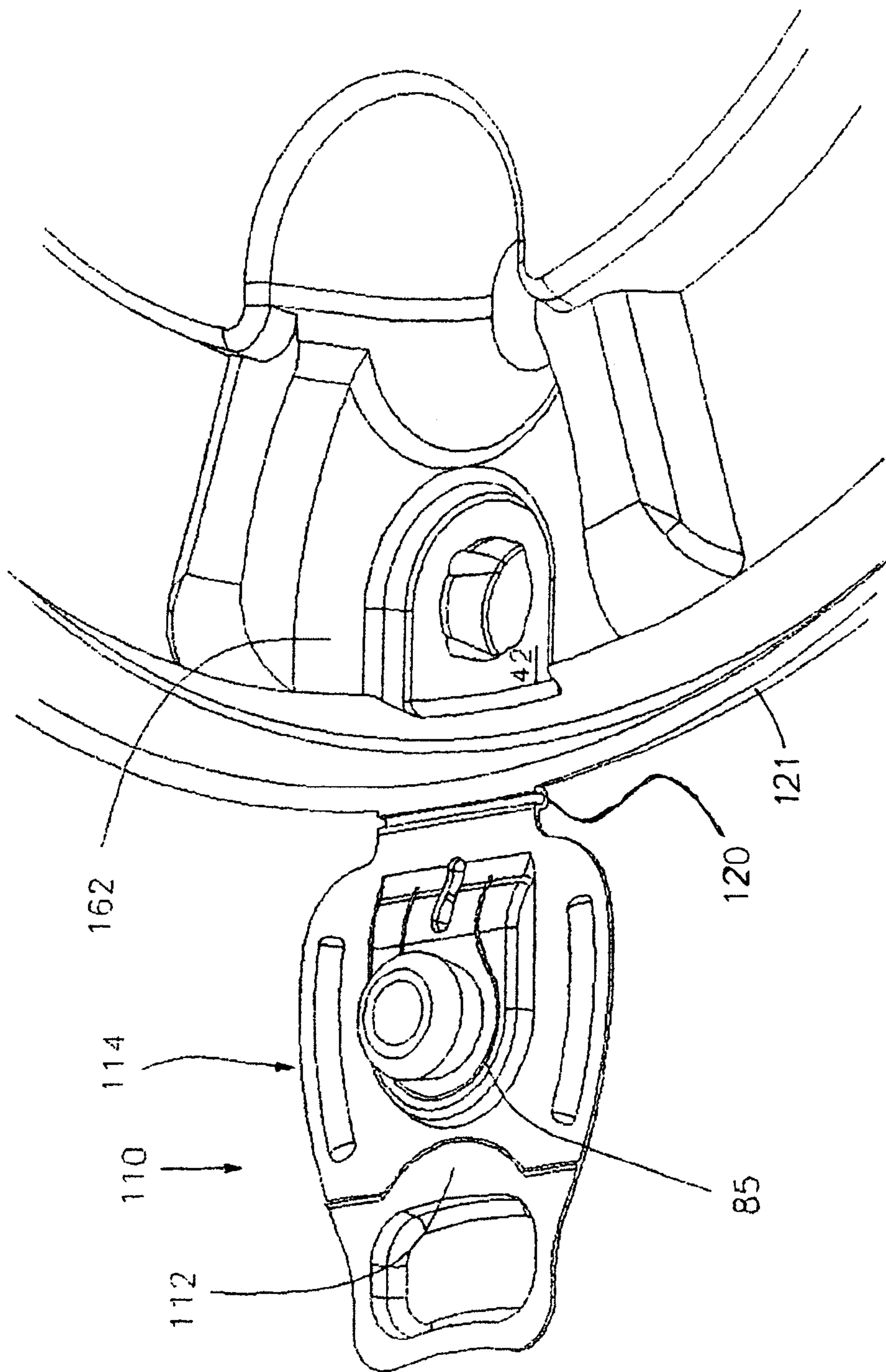
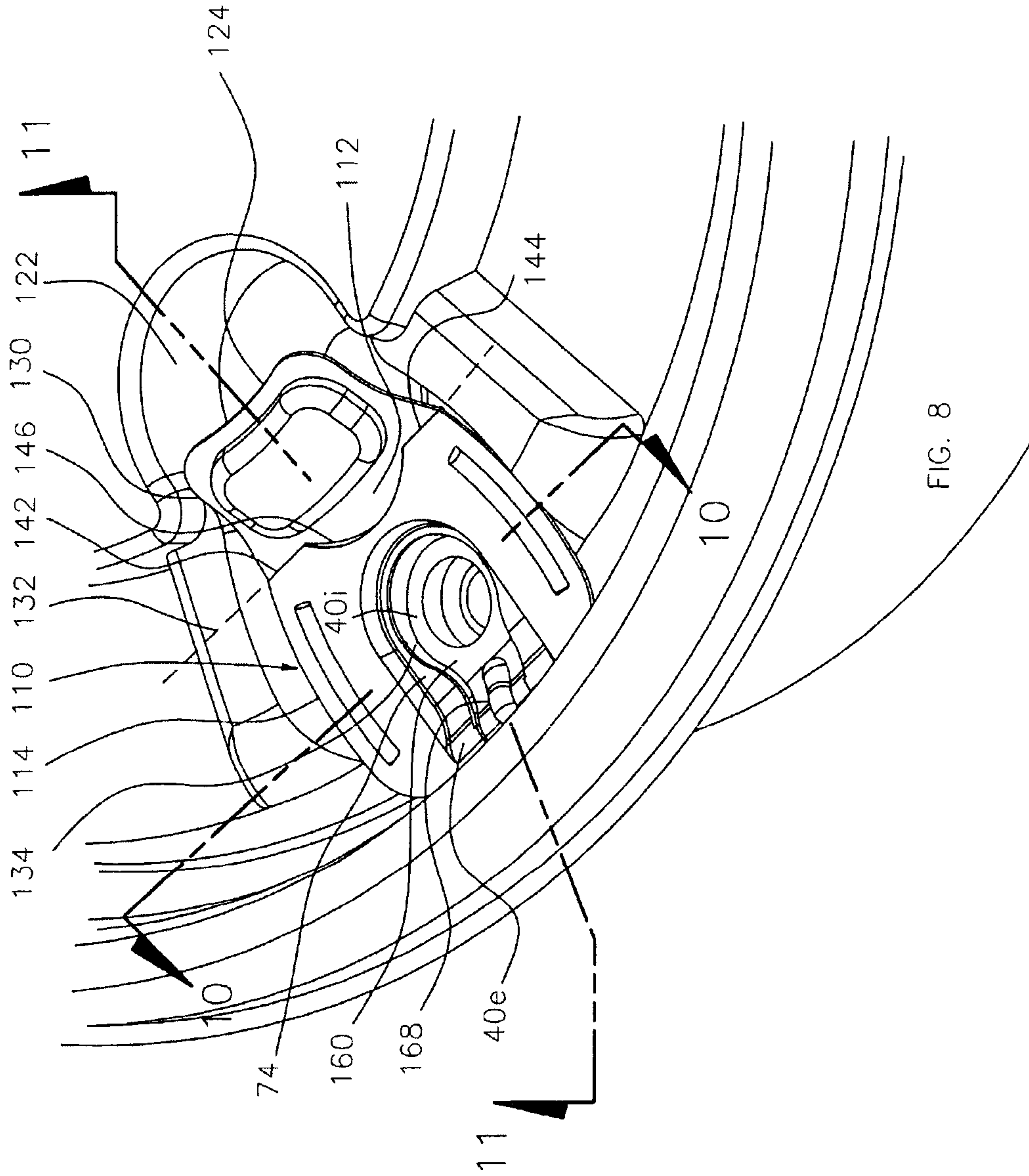

FIG. 7



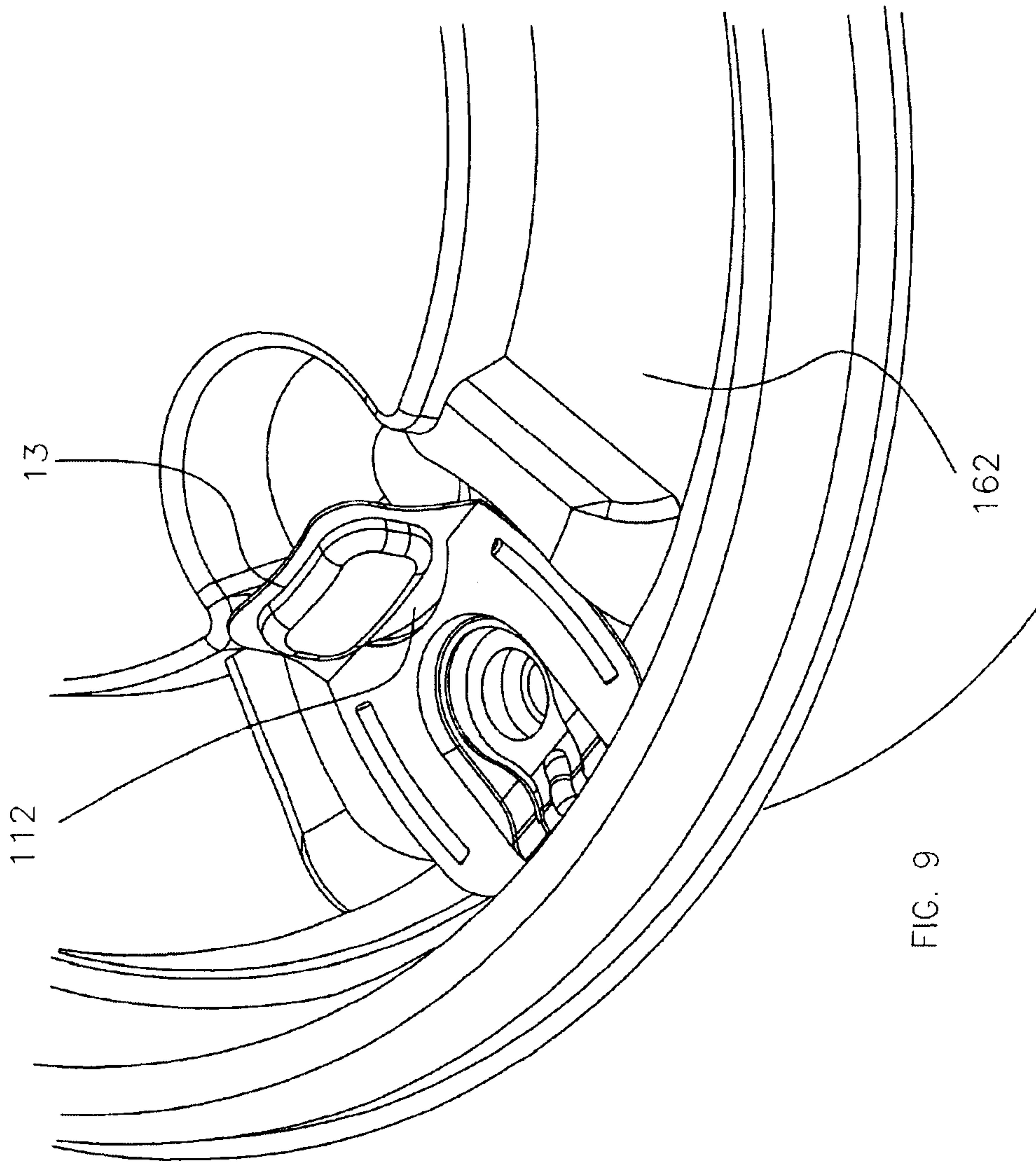

FIG. 9

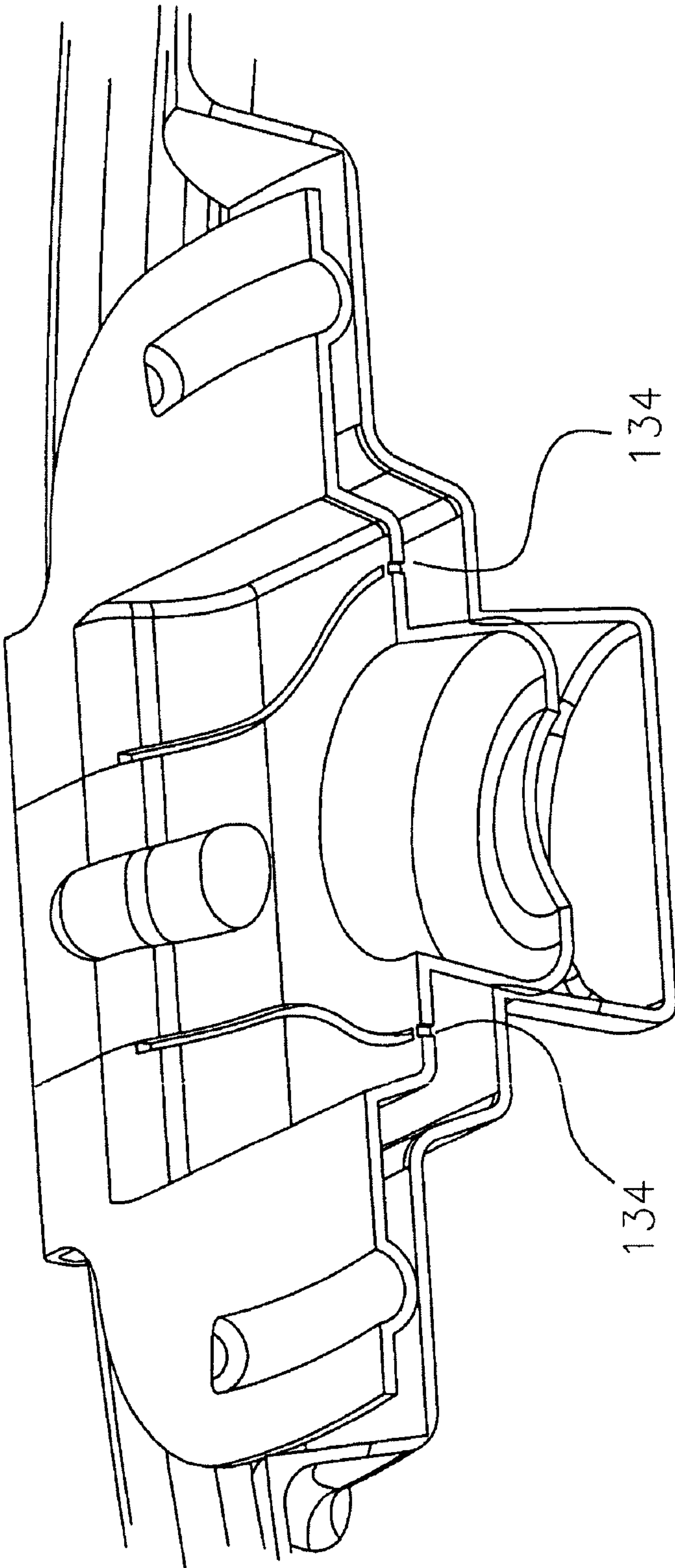

FIG. 10

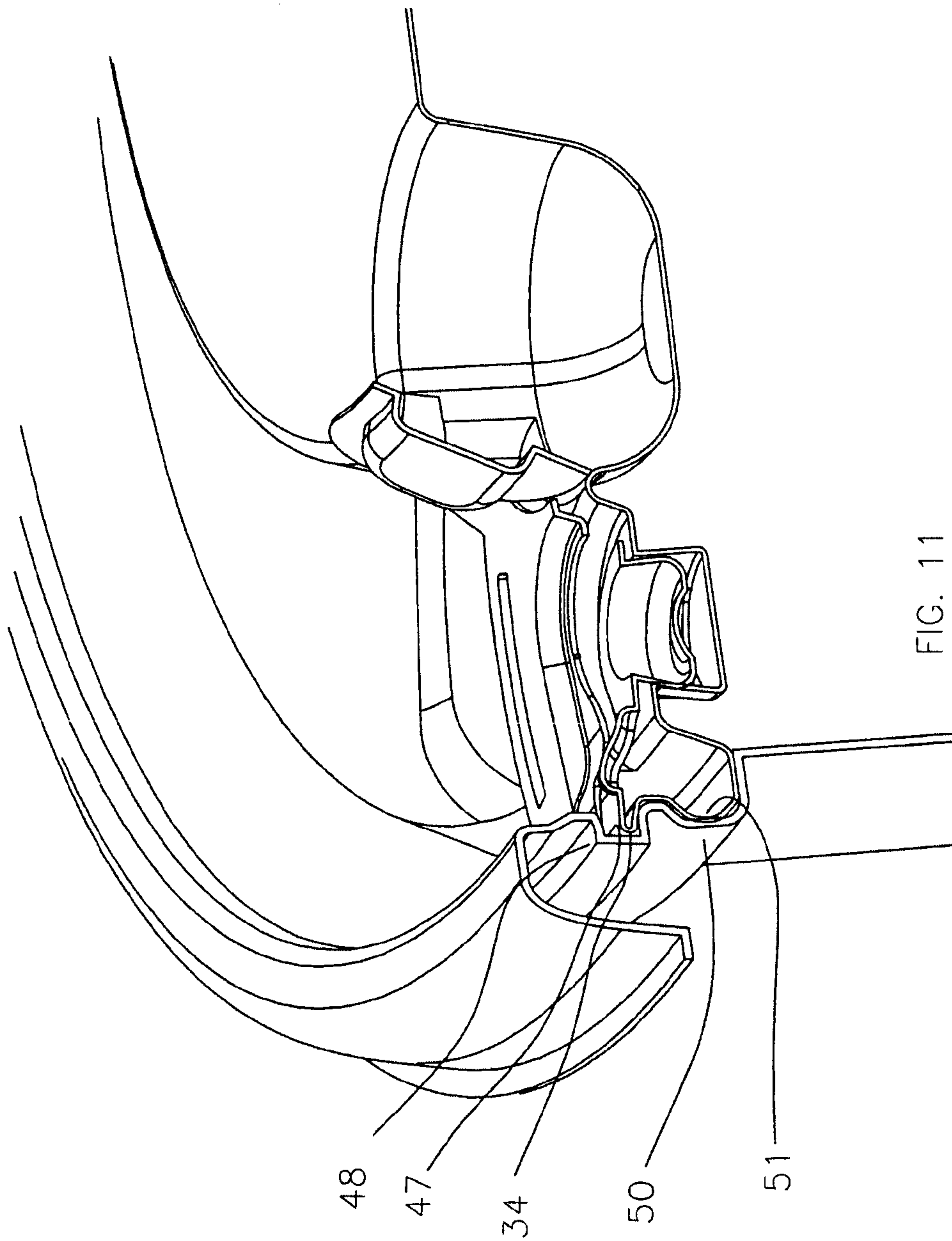

FIG. 11

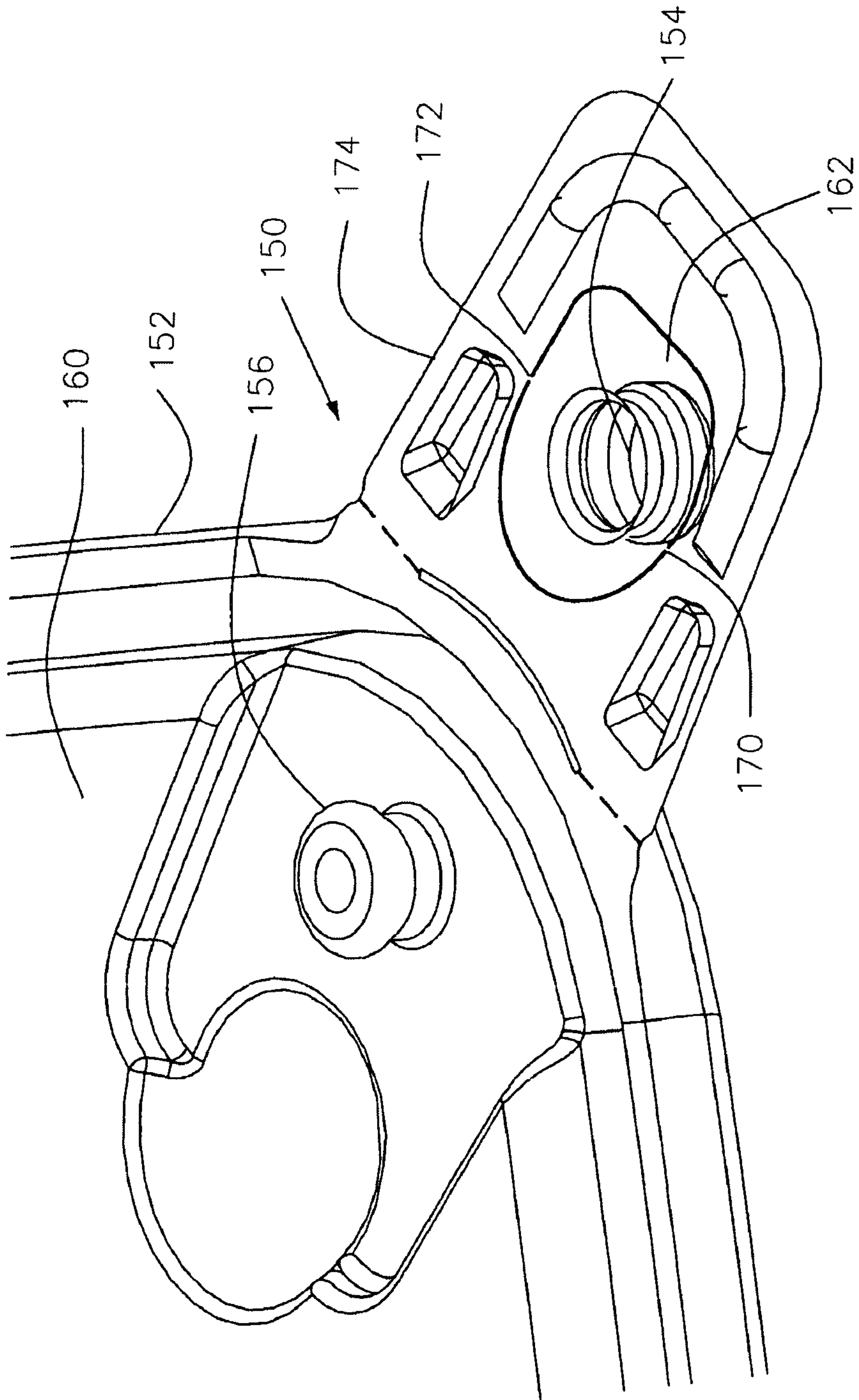

FIG. 12

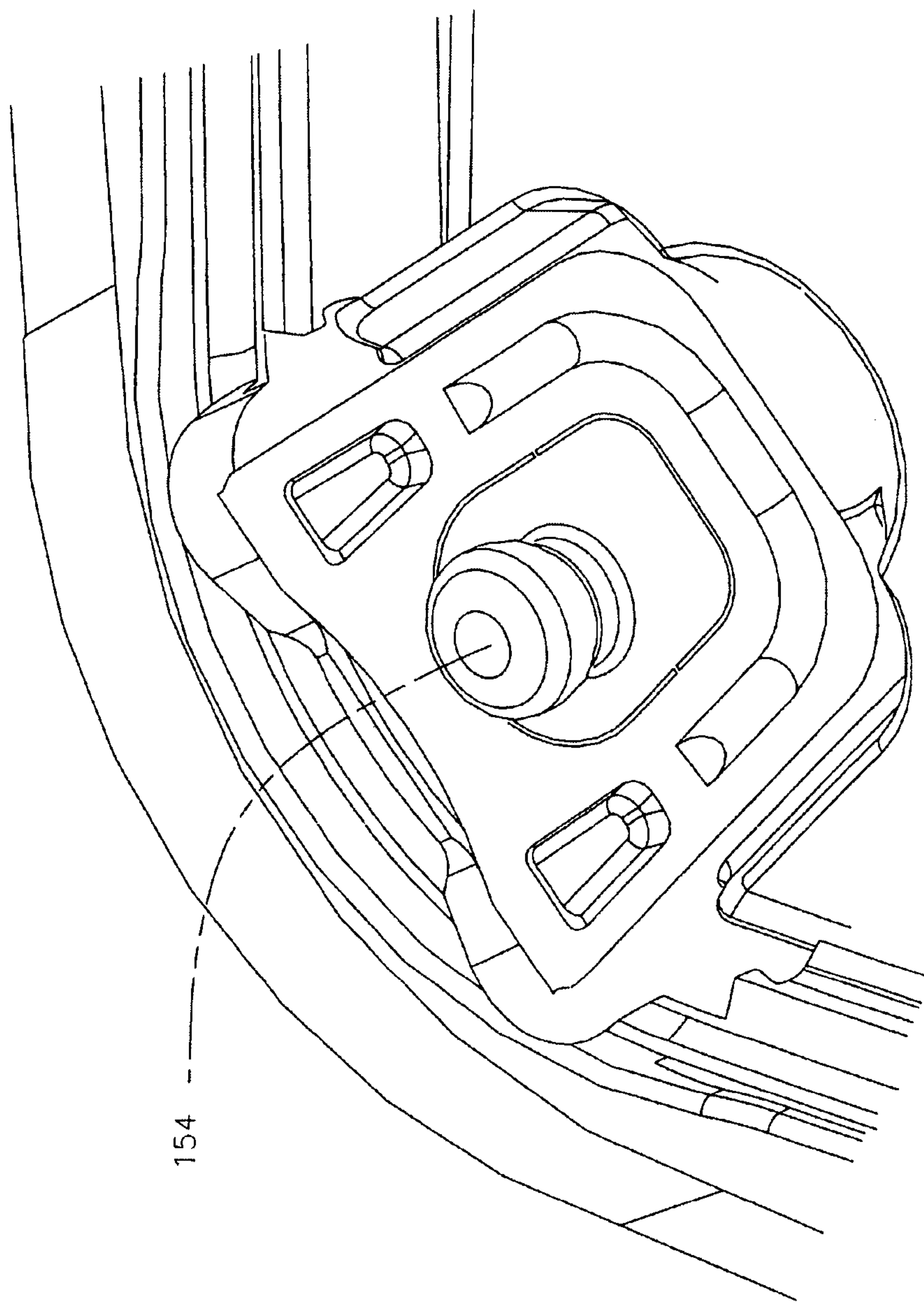

FIG. 13

154

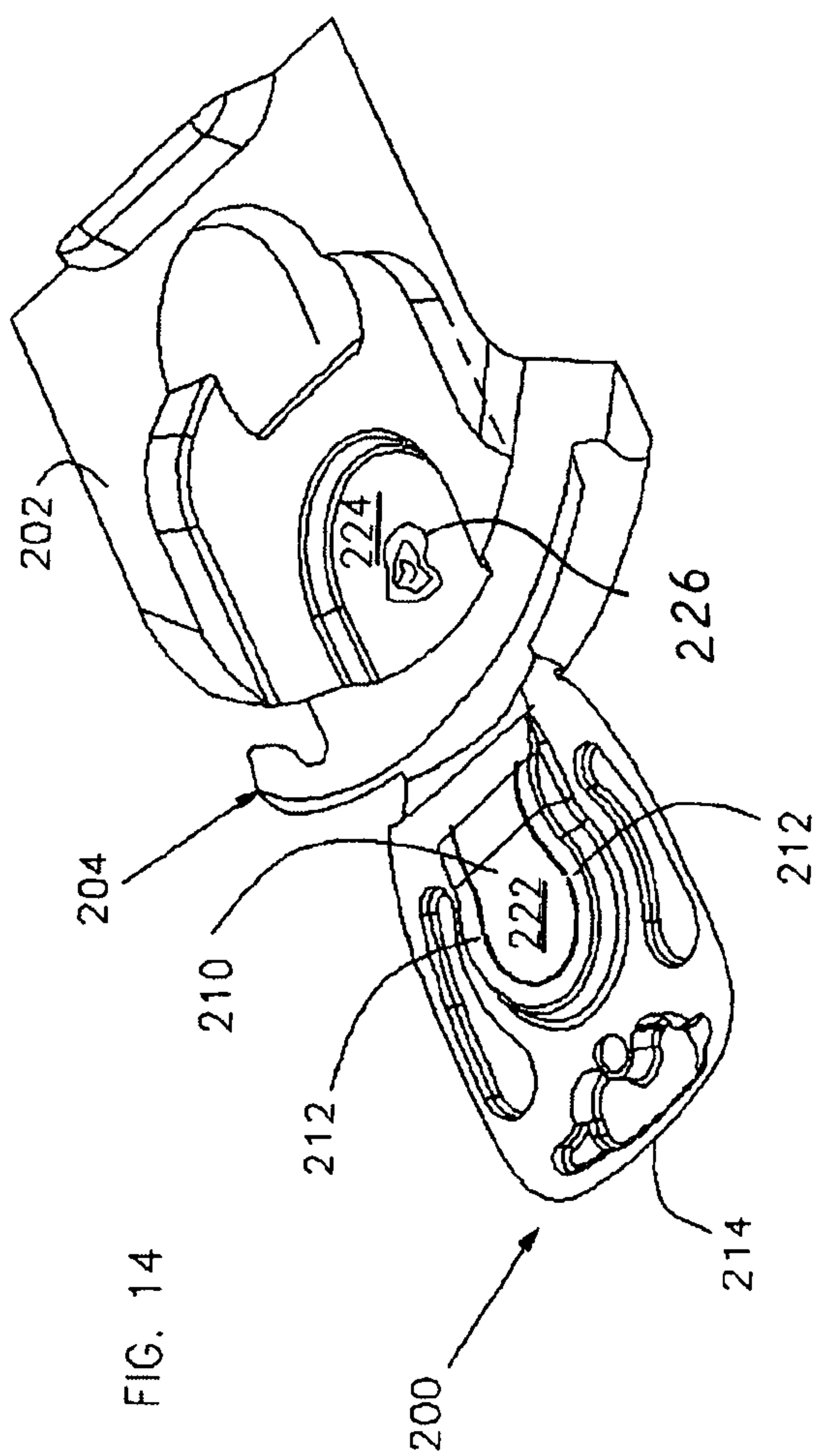

FIG. 14

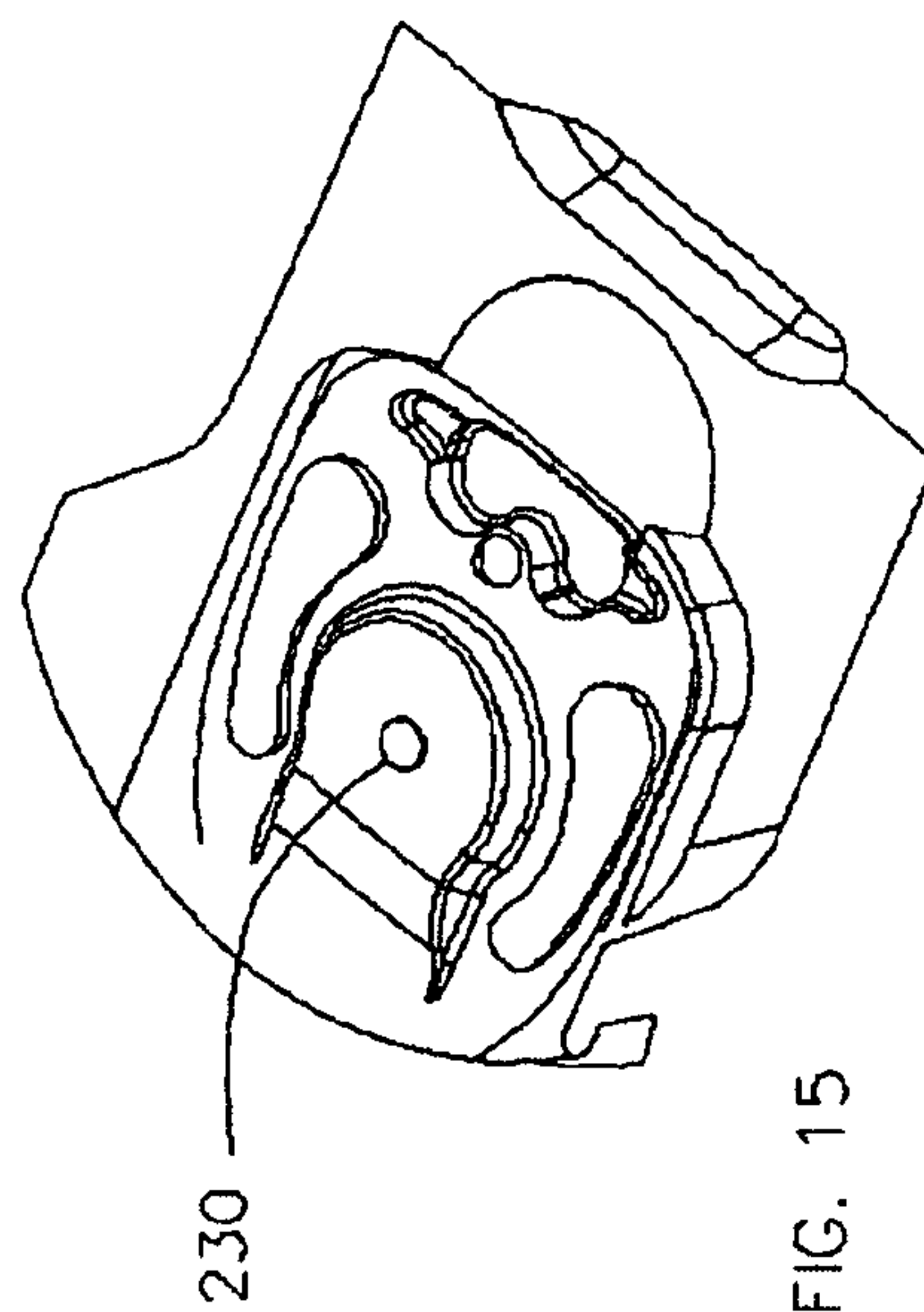

FIG. 15

