

(12) STANDARD PATENT
(19) AUSTRALIAN PATENT OFFICE

(11) Application No. **AU 2006346692 B2**

- (54) Title
Improvements to capsules containing a substance in powder form from which a beverage, preferably espresso coffee, is to be extracted
- (51) International Patent Classification(s)
B65D 85/804 (2006.01)
- (21) Application No: **2006346692** (22) Date of Filing: **2006.12.04**
- (87) WIPO No: **WO08/011913**
- (30) Priority Data
- | | | |
|----------------------|-------------------|--------------|
| (31) Number | (32) Date | (33) Country |
| MI2006A001503 | 2006.07.28 | IT |
- (43) Publication Date: **2008.01.31**
(44) Accepted Journal Date: **2013.04.04**
- (71) Applicant(s)
ILLYCAFFE' S.P.A.
- (72) Inventor(s)
Van Eeden, Frans;Vozza, Luigi;Bolzicco, Claudio;Dellapietra, Bruno;Suggi Liverani, Furio;Mastropasqua, Luca
- (74) Agent / Attorney
Watermark Patent and Trade Marks Attorneys, Level 2 302 Burwood Road, HAWTHORN, VIC, 3122
- (56) Related Art
EP 1 580 143 A1
US 5008013 A
US 5813317 A
US 2002/0124753 A1

(19) World Intellectual Property Organization
International Bureau



(43) International Publication Date
31 January 2008 (31.01.2008)

PCT

(10) International Publication Number
WO 2008/011913 A1

- (51) International Patent Classification:
B65D 85/804 (2006.01)
- (21) International Application Number:
PCT/EP2006/011621
- (22) International Filing Date:
4 December 2006 (04.12.2006)
- (25) Filing Language: English
- (26) Publication Language: English
- (30) Priority Data:
MI2006A001503 28 July 2006 (28.07.2006) IT
- (71) Applicant (for all designated States except US): **ILLY-CAFFÈ' S.P.A.** [IT/IT]; Via Flavia, 110, I-34147 Trieste (IT).
- (72) Inventors; and
- (75) Inventors/Applicants (for US only): **MAS-TROPASQUA, Luca** [IT/IT]; Via Belpoggio, 2, I-34123 Trieste (IT). **DELLAPIETRA, Bruno** [IT/IT]; Via Sistiana, 104, I-34013 Duino Aurisina (IT). **VAN EEDEN, Frans** [NL/IT]; Via G. Meda, 11, I-20136 Milano (IT). **SUGGI LIVERANI, Furio** [IT/IT]; Via Hermet, 6, I-34123 Trieste (IT). **BOLZICCO, Claudio** [IT/IT]; Viale Dante, 18, I-33170 Pordenone (IT). **VOZZA, Luigi** [IT/IT]; Via San Pio X, 7, I-34139 Trieste (IT).
- (74) Agent: **ALAGEM MODIANO, Lara, S.**; Modiano & Associati, Via Meravigli, 16, I-20123 Milano (IT).
- (81) Designated States (unless otherwise indicated, for every kind of national protection available): AE, AG, AL, AM, AT, AU, AZ, BA, BB, BG, BR, BW, BY, BZ, CA, CH, CN, CO, CR, CU, CZ, DE, DK, DM, DZ, EC, EE, EG, ES, FI, GB, GD, GE, GH, GM, GT, HN, HR, HU, ID, IL, IN, IS, JP, KE, KG, KM, KN, KP, KR, KZ, LA, LC, LK, LR, LS, LT, LU, LV, LY, MA, MD, MG, MK, MN, MW, MX, MY, MZ, NA, NG, NI, NO, NZ, OM, PG, PH, PL, PT, RO, RS, RU, SC, SD, SE, SG, SK, SL, SM, SV, SY, TJ, TM, TN, TR, TT, TZ, UA, UG, US, UZ, VC, VN, ZA, ZM, ZW.
- (84) Designated States (unless otherwise indicated, for every kind of regional protection available): ARIPO (BW, GH, GM, KE, LS, MW, MZ, NA, SD, SL, SZ, TZ, UG, ZM, ZW), Eurasian (AM, AZ, BY, KG, KZ, MD, RU, TJ, TM), European (AT, BE, BG, CH, CY, CZ, DE, DK, EE, ES, FI, FR, GB, GR, HU, IE, IS, IT, LT, LU, LV, MC, NL, PL, PT, RO, SE, SI, SK, TR), OAPI (BF, BJ, CF, CG, CI, CM, GA, GN, GQ, GW, ML, MR, NE, SN, TD, TG).
- Published:
— with international search report
— with amended claims

[Continued on next page]

(54) Title: IMPROVEMENTS TO CAPSULES CONTAINING A SUBSTANCE IN POWDER FORM FROM WHICH A BEVERAGE, PREFERABLY ESPRESSO COFFEE, IS TO BE EXTRACTED

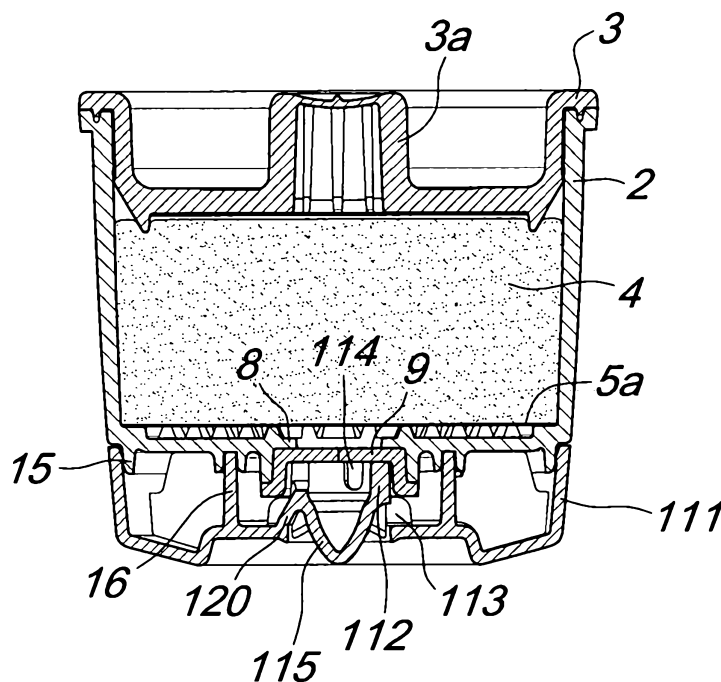

(57) Abstract: A capsule for extracting a beverage from a substance in powder form, preferably ground coffee, by means of pressurized water, comprising a box-like body (2, 3) which contains the substance in powder form (4) and has a base provided with an output port (8) for the outflow of the extracted beverage, the output port (8) being closed by an elastic crema forming septum (9) which can open under the pressure of the water, the capsule further comprising a safety lid (111) which is mounted on the box-like body at the base so as to increase the axial size of the box-like body, the lid (111) comprising a shoulder (112) which is engaged on the septum (9) and is adapted to retain the septum (9) within the capsule.

WO 2008/011913 A1



For two-letter codes and other abbreviations, refer to the "Guidance Notes on Codes and Abbreviations" appearing at the beginning of each regular issue of the PCT Gazette.

IMPROVEMENTS TO CAPSULES CONTAINING A SUBSTANCE IN
POWDER FORM FROM WHICH A BEVERAGE, PREFERABLY
ESPRESSO COFFEE, IS TO BE EXTRACTED

Technical Field

5 The present invention relates to improvements to capsules containing
a substance in powder form from which a beverage, preferably espresso
coffee, is to be extracted.

Background Art

10 It is known that machines for preparing espresso coffee, typically
used in bars and restaurants, require a dose of roasted and ground coffee to
be placed in an extraction chamber provided with a filtering container. This
container may be part of the so-called filter basket holder, which is filled by
hand with the dose of ground coffee (typically 7 ± 1 g for each cup to be
dispensed) and subsequently mounted on the machine in order to proceed
15 with the extraction of the beverage.

Machines for preparing espresso coffee are provided internally with a
boiler for heating the water drawn from a tank or other source and a pump
for sending to the delivery duct hot water at a selected pressure.

20 The traditional method for extracting the beverage by means of
known machines consists typically of a first preinfusion step, in which the
flow-rate of water entering at 90 ± 2 °C is reduced for a certain time interval;
a second impregnation step; and a third extraction step, in which the coffee
cake is crossed by a stream of hot water at 90 ± 2 °C at a constant pressure of
9 bars at the input of the cake of powdered coffee.

25 The beverage obtained from traditional espresso coffee machines is
usually clearly distinguishable from the beverage obtained at home with
coffee pots or infusion devices not only because the properties of flavor,
aroma and body are different but also because the beverage obtained from
traditional espresso coffee machines is characterized by a surface layer of
30 foam, also known as crema. Crema is an attribute of the coffee beverage

which is particularly appreciated by the consumer and is an indicator of correct preparation of the beverage.

WO 2005/092160 and WO 2005/092162 disclose a particular capsule which contains a substance in powder form, preferably roasted and ground coffee, the capsule being provided with an elastic septum which generates crema and by means of which it is possible to extract a beverage with improved physical and organoleptic characteristics.

The known elastic septum is fixed downstream of the dose of substance in powder form and of the corresponding filter sheet and is characterized by an elastic membrane which has at least one through orifice or gap provided in a central region, so as to open and allow the passage of the beverage only when the internal pressure exceeds a certain value.

A drawback observed in known capsules is linked to the length of the capsule manufacturing time. In the particular case of capsules provided with an elastic septum, some operations which slow down the manufacturing process are linked to the preparation, installation and fixing of the elastic septum within the capsule.

Another drawback is due to the fact that typically capsules which contain ground coffee use paper-based filters in order to retain the solid fractions within the capsule and prevent them from being poured into the cup. The choice of paper-based filters can entail limitations in the design of the capsule; for example, it forces to design the bottom of the capsule so that there are no regions in which the filter paper might break due to the pressure inside the capsule or due to surface unevenness or openings.

25 **Disclosure of the Invention**

The aim of the present invention is to obviate the drawbacks of known capsules by providing improvements which allow a considerable reduction in the manufacturing times and costs of said capsule.

Within this aim, an object of the invention is to allow particularly quick and simple installation and fixing of the crema forming septum.

Another object of the invention is to provide a capsule which allows safe and reliable operation of the capsule throughout beverage extraction without losing in quality with respect to known capsules.

According to a first aspect of the invention, this aim and these and
5 other objects, which will become better apparent hereinafter, are achieved by a capsule for extracting a beverage from a substance in powder form, preferably ground coffee, by means of pressurized water, comprising a box-like body which contains the substance in powder form, the box-like body having a base provided with an output port for the outflow of the extracted
10 beverage, the output port being substantially closed by an elastic crema forming septum which can open under pressure, characterized in that it comprises a safety lid which is mounted on the box-like body at the base so as to increase the axial size of the box-like body, said lid comprising a shoulder which is engaged on the septum and is adapted to retain the septum
15 within the capsule.

According to another aspect of the invention, the intended aim and objects are achieved by a flat filter for single-use capsules containing substances in powder form from which a beverage is to be extracted, characterized in that it is made of plastics and is adapted to retain the solid
20 particles of the beverage extracted from the capsule. The filter comprises a plurality of passages having a diameter of preferably 0.6 mm or less and if possible of at least 0.1 mm. The passages can be arranged on the filter with a spacing of at least 1.2 mm.

According to still another aspect of the invention, the intended aim
25 and objects are achieved by a crema forming septum adapted to be installed downstream of a chamber which contains a substance in powder form, preferably ground coffee, for extracting a beverage by means of water under pressure, characterized in that it comprises an elastic membrane provided with a blind orifice which is adapted to be broken by the beverage during
30 extraction.

The membrane is preferably made of thermoplastic elastomer (TPE), preferably SEBS and even more preferably Laprene[®] or of another material which allows the elastic membrane to be molded together with the plastic box-like body of the capsule in a single step of manufacture by means of co-
5 molding, overmolding or coextrusion techniques. However, the membrane might also not be fixed directly to a capsule which contains the substance in powder form but might be fixed to an external support, installing it for example directly on the capsule holder of the beverage extraction machine.

Brief description of the drawings

10 Further characteristics and advantages of the invention will become better apparent from the description of preferred but not exclusive embodiments thereof, illustrated by way of non-limiting example in the accompanying drawings, wherein:

Figure 1 is an exploded perspective view of the capsule according to
15 a first embodiment of the invention;

Figure 2 is a sectional view of the exploded view of Figure 1 from another viewpoint;

Figure 3 is an axial sectional view of the capsule of Figures 1 and 2;

Figure 4 is an axial sectional view of the capsule according to a
20 second embodiment of the invention;

Figure 5 is a bottom perspective view of the capsule according to a third embodiment of the invention;

Figure 6 is an axial sectional view of the capsule of Figure 5;

Figure 7 is an axial sectional view of a septum according to a
25 particular aspect of the invention;

Figure 8 is a plan view of a plastic filter according to a particular aspect of the invention.

In the following description, identical reference numerals designate elements which are identical or have an equivalent technical function.

30 Ways of carrying out the Invention

With reference to Figures 1 to 3, the capsule according to the invention, generally designated by the reference numeral 1, is substantially cylindrical (but it can also be frustum-shaped or prism-like) and comprises a box-like body which is formed preferably by two portions, i.e., a cup-shaped
5 portion 2 and an element 3 for closing in an upward region the cup-shaped portion 2. The closure element 3 is provided with an input port 3a, which preferably but not necessarily protrudes and is closed and can be opened in a known manner by the beverage extraction machine by piercing in order to allow the inflow of hot water under pressure into the capsule. The cup 2 and
10 the closure element 3 are welded together preferably by means of ultrasound or known similar techniques, as disclosed in prior WO 2005/092160 and WO 2005/092162.

The box-like body 2, 3 contains a substance in powder form 4, preferably ground coffee, which is suitable to allow the extraction of a
15 beverage, for example espresso coffee, by means of water under pressure. The substance in powder form 4 can be comprised between two filtering elements 5a and 5b, which are adapted to retain the solid fractions, for example the granular coffee residues, within the capsule.

The box-like body of the capsule has a base 6 provided with an output
20 port 7 for the outflow of the extracted beverage. The base comprises preferably a plurality of ridges 61, which are adapted to define a narrow channel between the base and the lower filter 5a in order to convey the extracted beverage toward the output port 7.

The output port 7, arranged preferably in a central region of the base
25 6 and surrounded by a rim 8, is substantially closed by an elastic crema forming septum 9 which can open under pressure.

The septum 9 preferably comprises an elastic membrane made of elastomeric or rubber-like material, for example a TPE such as SEBS (a styrene-ethylene-butylene-styrene block copolymer) or Laprene® (based on
30 SEBS and polyolefins).

The elastic membrane can comprise a through orifice 10, which is adapted to keep normally closed the septum 9 and therefore the beverage output port 7 when the capsule 1 is not used and is adapted to allow the beverage to pass when the pressure inside the capsule exceeds a certain value, for example 6 bars, causing a deformation and therefore a widening of the orifice 10.

As an alternative to the through orifice 10, the elastic membrane can comprise a blind orifice 110, which can be opened by breaking when the pressure in the capsule reaches a certain threshold, as discussed hereinafter with reference to Figure 7.

The elastic septum 9 can be co-molded together with the box-like body 2, 3 of the capsule 1, which is preferably made of polypropylene, so as to eliminate intermediate mechanical operations for fixing the septum 9 to the rim 8 of the output port 7.

As an alternative, the elastic membrane can be co-molded together with a rigid supporting ring 9a, such as the one shown in cross-section in Figures 7 and 4, which is adapted to be interlocked in a protruding cylindrical rim of the output port 7.

The capsule 1 further comprises a safety lid 11, which is mounted on the box-like body at the base 6 so as to increase the axial dimension of the box-like body. More specifically, the lid 11 is fixed to the box-like body of the capsule so as to protrude substantially from the base 6 substantially in the direction of the axis of symmetry of the capsule along the direction of the stream of water.

The lid 11 is preferably fixed mechanically to a peripheral rim 15 of the base 6, for example by snap action, so as to allow its quick fitting to the box-like body of the capsule 1.

The safety lid 11 is provided with a shoulder 12 which is engaged on the septum 9 and is adapted to retain the septum 9 against the output port 7 provided in the base 6, so as to prevent the septum from being accidentally

expelled from the capsule due to the high pressures reached during beverage extraction. In the second embodiment of the capsule, shown in Figure 4, the shoulder 12 engages the rigid annular support 9a of the septum, which is locked inside the protruding cylindrical rim 8a of the output port 7.

5 The shoulder 12 can have at least a passage 14 in order to allow the beverage to exit from the capsule 1 by passing through the safety lid 11. For this purpose, the lid 11 comprises at least an output opening 13, which in the particular embodiment of Figures 1 to 4 is laterally displaced with respect to the central axis of the output port 7 or with respect to the axis of
10 symmetry of the capsule 1.

 The passage 14 on the shoulder 12 and the output opening 13 of the lid 11 are arranged advantageously on opposite sides with respect to the central axis of the output port 7, thus forming a winding path for the extracted beverage, which reduces its speed.

15 Optionally, the lid 11 can be provided with a second closed cylindrical wall 16, which surrounds the shoulder 12 and can be interlocked within an appropriately provided circular seat 17 which is defined on the base 6 around the output port 7. The walls 12 and 16 thus define a
20 cylindrical ring in which the beverage that exits from the orifice 10 of the septum 9 flows before reaching the output opening 13 provided in the safety lid 11.

 As an alternative, as shown in Figures 5 and 6, the safety lid 111 used in a third embodiment of the invention can comprise an output opening 113 which is substantially annular and substantially coaxial to the output port 7
25 of the box-like body of the capsule and is adapted to allow the beverage to exit from the capsule in a direction which practically coincides with the axis of the capsule, differently from the embodiments of Figures 1-4, in which the flow is displaced laterally with respect to the axis.

 The annular opening 113 is defined in a through hole of the lid 111
30 between the rim of the through hole and an ogive-shaped element 115,

which is supported by the lid 111 by means of supporting arms 120 and is arranged in the through hole.

The ogive-shaped element is provided with a shoulder 112 which is similar to the shoulder 12 of Figures 1 to 4, i.e., it is engaged on the elastic septum 9 in order to retain the septum against the rim of the output port 7. In the capsule of Figures 5 and 6 also, the shoulder 112 is a partially open cylindrical wall, i.e., a wall provided with at least one passage 114.

As can be seen, the advantageous combination of a safety lid which is mounted so as to increase the axial dimension of the box-like body and of the shoulder in order to lock in its seat the elastic septum allows to ensure on the one hand the provision of a tool which is convenient and quick for the safety locking of the elastic septum within the capsule and on the other hand prevents the capsule from being used to extract a beverage if the safety means for retaining the septum within the capsule, i.e., the safety lid 11 or 111, is not present.

If the capsule 1 is in fact accidentally mounted without the safety lid 11 or 111 in a filter basket holder of a machine for extracting the beverage or espresso coffee, for example of the type disclosed in prior WO 2005/092162, the input port 3a of the capsule cannot be reached and/or pierced by the hot water injector of the machine, because it is too distant from the piercing needle. Therefore, in addition to simplifying and speeding up the capsule manufacturing operations, the invention allows advantageously to prevent the unintended use of a defective capsule, i.e. a capsule which is subject to the accidental expulsion of the elastic septum toward the cup or vessel in which the beverage is collected.

In the embodiments described so far, the elastic septum 9 is provided with an elastic membrane with a central through orifice 10. However, in order to simplify and speed up the manufacture of capsules which contain an elastic crema forming septum, the elastic membrane of the septum 9 can be molded so that it has a weaker region 110. The weaker region 110 is a

prefracture region, i.e., a region which is adapted to be broken by the pressurized beverage during extraction. In this manner, the septum is formed completely in a single operation and does not require the additional piercing operations used for example in the manufacture of the septum of the capsules described in prior WO 2005/092160.

In the case shown in Figure 7, the elastic membrane with a prefracture region 110 is applied to a rigid supporting ring 9a, to be used when the septum 9 is fixed mechanically to the cylindrical rim 8a of the output port (Figure 4) by means of a snap engagement of the annular support 9a with an appropriately provided annular recess formed on the inside of the cylindrical rim 8a.

However, as can be appreciated easily, the septum 9 with a prefracture region 110 can be molded together with the cup 2 of the capsule by co-molding, like the septum of the capsules shown in Figures 3 and 6. In this manner, by means of a single co-molding operation it is possible to manufacture a rigid box-like body which is already provided with an elastic crema forming septum without having to perform subsequent septum piercing operations.

With reference to Figure 8, according to yet another aspect of the invention, the lower flat filter 5a of the capsule 1 is made of plastics and is adapted to retain the solid particles of the beverage extracted from the capsule with the same effectiveness as filter paper. The filter 5a, obtained by multiple piercing of a plastic sheet having a thickness from 0.5 to 2.5 mm, comprises a plurality of passages 55 having a diameter from 0.1 to 0.6 mm. The passages can be arranged on the filter 5a with a periodic spacing w of at least 1.2 mm in the two perpendicular directions.

The filter allows not only to speed up the manufacture of the capsule but also to eliminate the drawbacks that might arise from the use of paper-based filters. For example, with the plastic filter it is possible to provide even an output port 7 which has a considerable diameter without having to

take into consideration the possibility of breakage of the lower filter due to excessive deformation, therefore without being limited to structures having small diameters of the output port or bridge-like supporting structures adapted to reduce the passage surface of the output port.

5 Moreover, the plastic filter can be made of the same material as the box-like body of the capsule, with considerable advantages in terms of production chain.

 Of course, the plastic flat filter is not limited only to the capsules described here but can be used in any capsule containing substances in
10 powder form for preparing beverages, particularly single-use capsules for preparing espresso coffee.

 In practice it has been found that the invention fully achieves the intended aim, since it allows to reduce considerably the manufacturing times of single-use capsules for preparing beverages such as espresso coffee,
15 eliminating some additional manufacturing steps which are separate from the molding of the capsule.

 The installation and fixing of the crema forming septum is particularly quick and simple and at the same time allows safe and reliable operation of the capsule throughout the beverage extraction step.

20 Moreover, the invention allows to remove some technical limitations in the design of the capsule.

 Although the invention has been conceived in particular for capsules suitable for preparing espresso coffee, it can in any case be used more generally for capsules which contain edible substances in general adapted to
25 produce a beverage by percolation.

 The capsule, the septum and the filter thus conceived are susceptible of numerous modifications and variations, all of which are within the scope of the appended claims. All the details may further be replaced with other technically equivalent elements.

30 In practice, the materials used, as well as the dimensions, may be any

according to requirements and to the state of the art.

The disclosures in Italian Patent Application No. MI2006A001503 from which this application claims priority are incorporated herein by reference.

- 5 Where technical features mentioned in any claim are followed by reference signs, those reference signs have been included for the sole purpose of increasing the intelligibility of the claims and accordingly, such reference signs do not have any limiting effect on the interpretation of each element identified by way of example by such reference signs.

THE CLAIMS DEFINING THE INVENTION ARE AS FOLLOWS:

- 2006346692 06 Mar 2013
- 5 1. A capsule for extracting a beverage comprising a containment body for containing a substance in powder form and having a cup-shaped portion the containment body having a cup-shaped portion, said cup-shaped portion comprising an external peripheral wall and a base provided with an internal output port for the outflow of the extracted beverage, said output port being closed by an elastic crema-forming septum which operatively opens under pressure, a safety lid mounted on said containment body at the base so as to increase an axial size
- 10 of the containment body, said safety lid having a shoulder which is engaged on the septum and is adapted to retain the septum within the capsule.
2. A capsule according to claim 1, wherein said safety lid is fixed to a peripheral rim of said base by snap engagement.
- 15 3. A capsule according to claim 1, wherein said safety lid comprises at least one output opening.
4. A capsule according to claim 3, wherein said at least one output opening is arranged on said lid in a position which is displaced laterally with respect to a central axis of the output port.
- 20 5. A capsule according to claim 3 or 4, wherein said at least one opening is annular and coaxial to said output port.
6. A capsule according to claim 5, wherein said annular opening is defined in a through hole of said safety lid between an ogive-shaped element arranged in said through hole and the rim of said through hole, said ogive-shaped element being supported by said lid by means of supporting arms.
- 25 7. A capsule according to any one or more of claims 1 to 6, wherein the crema-forming septum, which can open under pressure, comprises an elastic membrane which has a through orifice provided beforehand in the membrane or a weaker region which is adapted to be broken under pressure during beverage extraction.

8. A capsule according to claim 7, wherein said weaker region comprises a region which is a blind orifice thinner than said membrane.
9. A capsule according to any one or more of claims 1 to 8, wherein said containment body is made of plastic material, preferably polypropylene, and the crema-forming septum comprises a thermoplastic elastomer which is co-molded with said containment body at the rim of said output port.
10. A capsule according to any one or more of claims 1 to 8, wherein said output port comprises a cylindrical rim which protrudes axially from said base toward the outside of the containment body, the crema-forming septum being fixed mechanically to the internal surface of said cylindrical rim.
11. A capsule according to any one or more of claims 1 to 10, further comprising a plastic flat filter which is arranged inside said containment body, between the substance in powder form and the output port, said filter being adapted to prevent the passage of solid fractions of the beverage through the output port.
12. A capsule according to claim 11, wherein the plastic filter comprises a plurality of passages whose diameter is at most 0.6 mm.
13. A capsule according to claim 12, wherein the diameter of each of the passages is at least 0.1 mm.
14. A capsule according to claim 12 or 13, wherein the passages are arranged on said-filter with a spacing of at least 1.2 mm.
15. A capsule according to any one or more of claims 11 to 14, wherein said filter has a thickness from 0.5 to 2.5 mm.
16. A crema-forming septum, adapted to be installed downstream of a chamber which contains a substance in powder form, for extracting a beverage by means of pressurized water, the crema-forming septum comprising an elastic membrane which has a weaker region adapted to be broken by the pressurized beverage during extraction said weaker region being a prefracture blind orifice

having a thickness that is thinner than regions of said membrane adjacent said prefracture blind orifice.

17. A crema-forming septum according to claim 16, wherein said membrane is made of thermoplastic elastomer.

5

ILLYCAFFE' S.P.A.

WATERMARK PATENT AND TRADE MARKS ATTORNEYS

P31396AU00

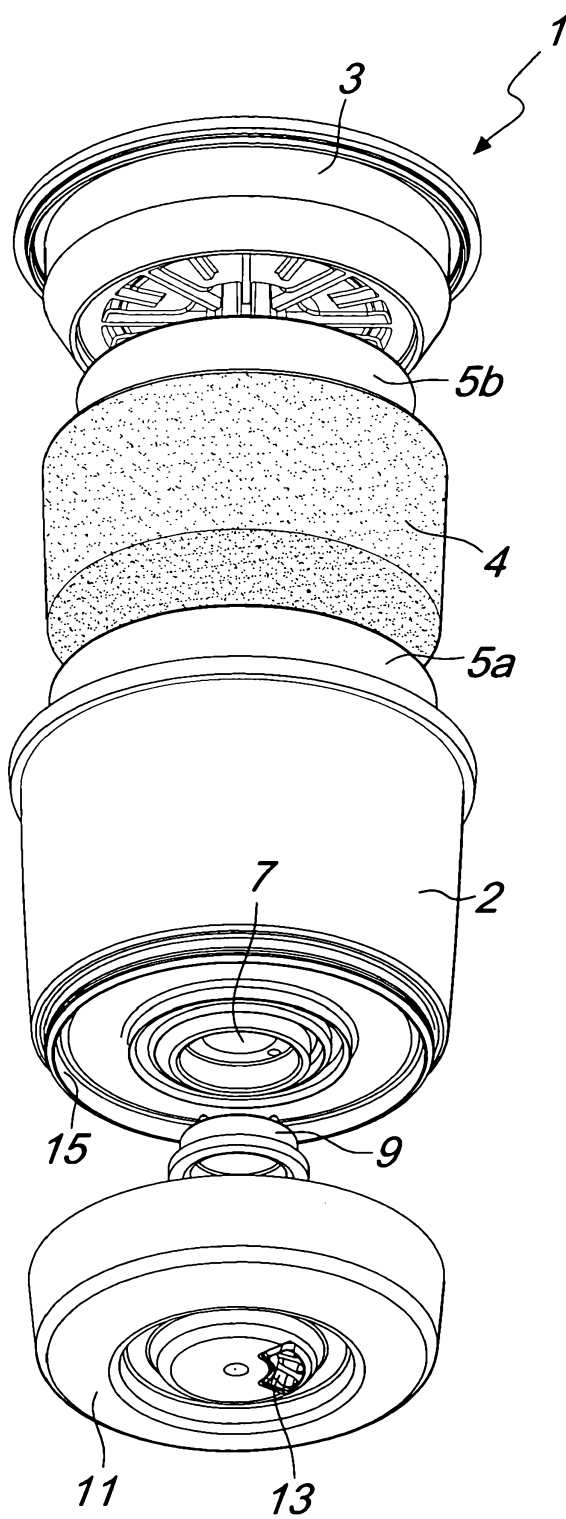

Fig. 1

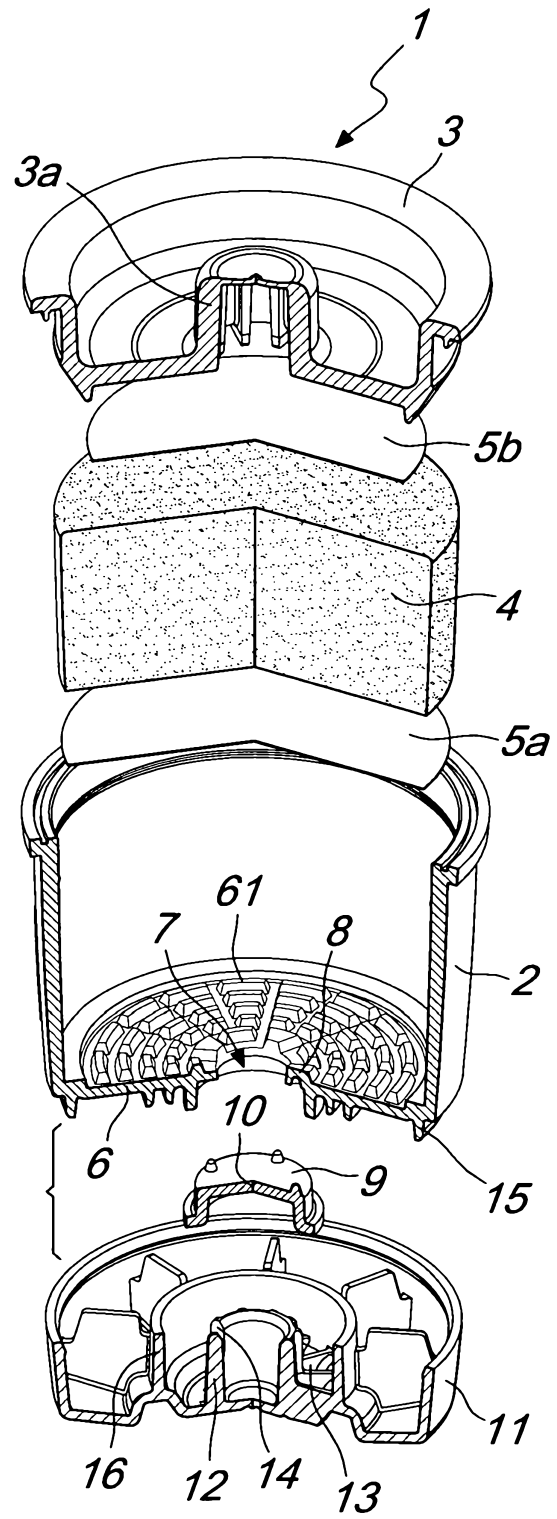

Fig. 2

2/3

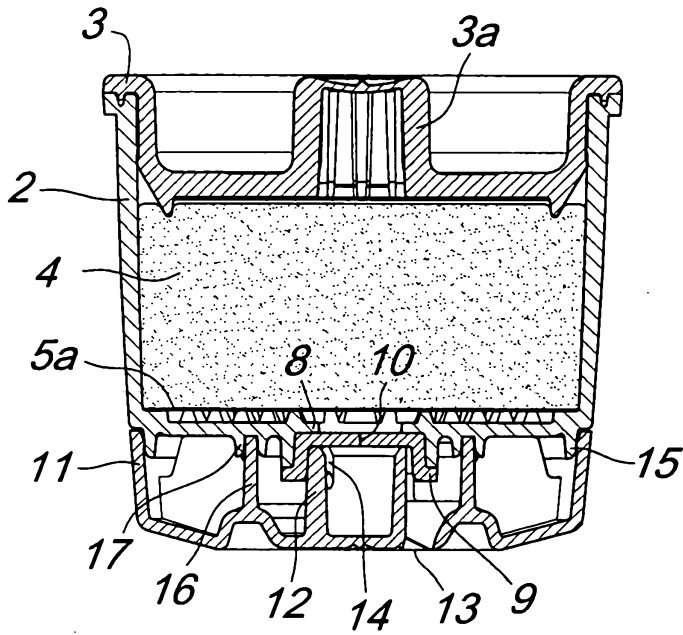

Fig. 3

Fig. 4

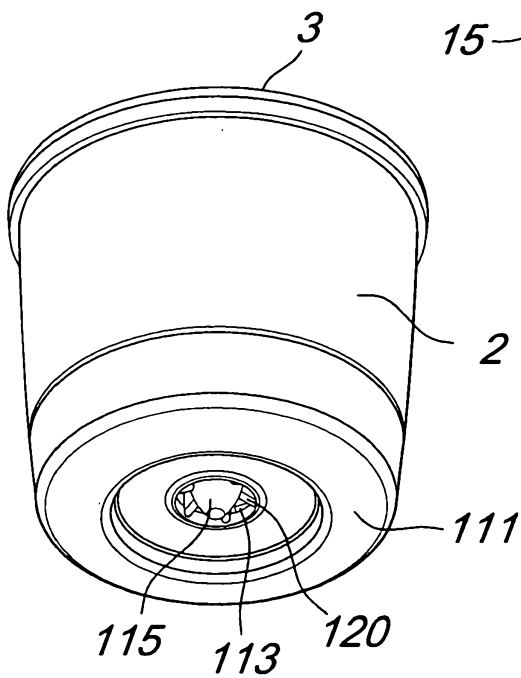
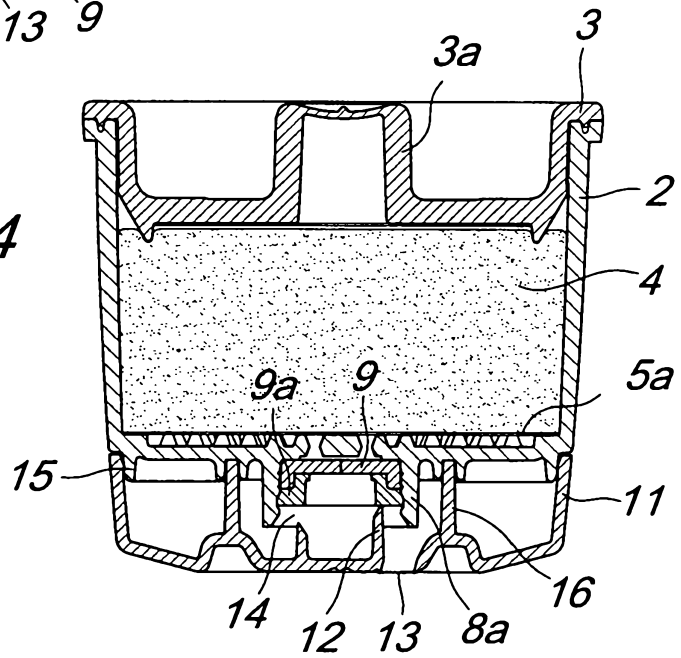

Fig. 5

3 / 3

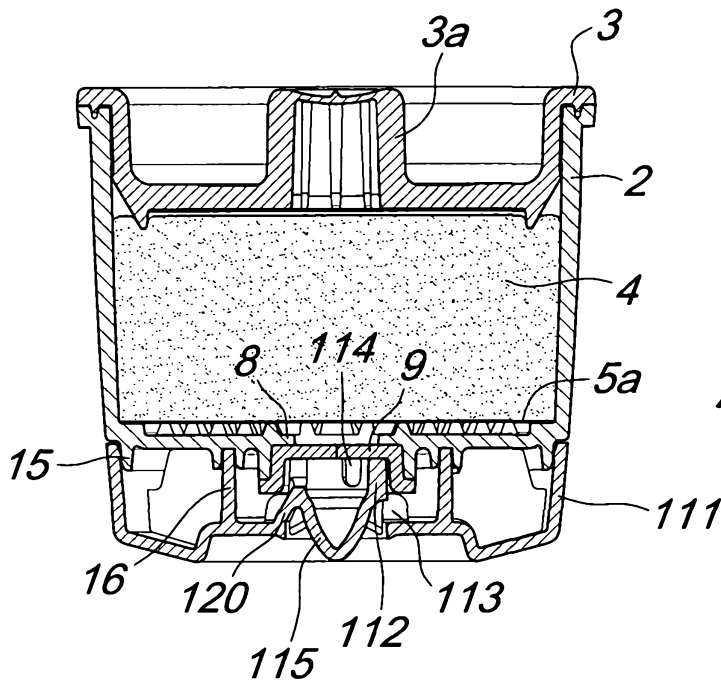

Fig. 6

Fig. 7

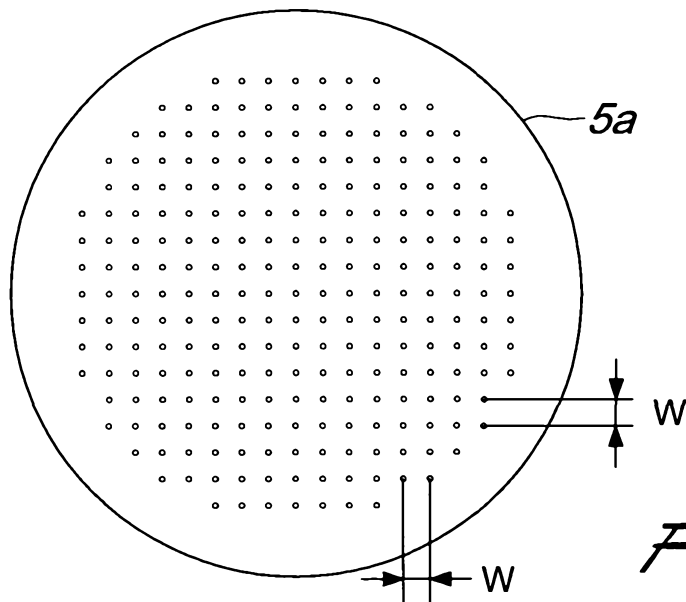
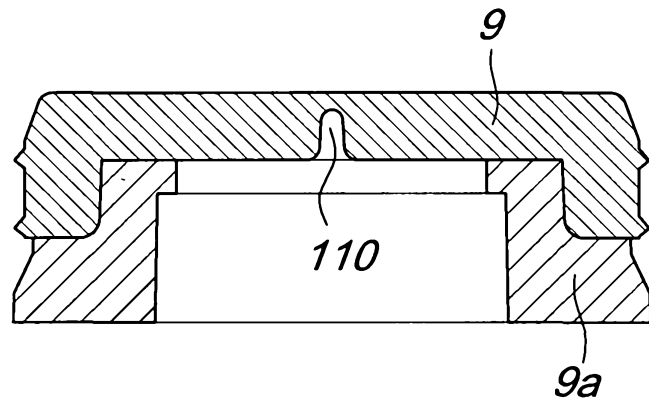

Fig. 8