

(19)



(11)

**EP 1 406 277 B1**

(12)

**EUROPEAN PATENT SPECIFICATION**

(45) Date of publication and mention of the grant of the patent:  
**11.12.2013 Bulletin 2013/50**

(51) Int Cl.:  
**H01H 19/63 (2006.01) H01H 19/635 (2006.01)**

(21) Application number: **03022620.3**

(22) Date of filing: **06.10.2003**

(54) **Rotary switch device**

Drehschalteranordnung

Système de commutateur rotatif

(84) Designated Contracting States:  
**DE FR GB SE**

(30) Priority: **04.10.2002 JP 2002292376**

(43) Date of publication of application:  
**07.04.2004 Bulletin 2004/15**

(73) Proprietor: **KABUSHIKI KAISHA TOKAI RIKA DENKI SEISAKUSHO**  
**Niwa-gun,**  
**Aichi 480-0195 (JP)**

(72) Inventors:  
 • **Hayakawa, Junichi**  
**Ohguchi-cho**  
**Niwa-gun**  
**Aichi (JP)**

• **Shimizu, Tetsuya**  
**Ohguchi-cho**  
**Niwa-gun**  
**Aichi (JP)**

(74) Representative: **Grünecker, Kinkeldey, Stockmair & Schwanhäusser**  
**Leopoldstrasse 4**  
**80802 München (DE)**

(56) References cited:  
**DE-C1- 19 722 780 FR-A- 2 403 638**  
**FR-A- 2 785 084 US-A- 5 905 237**  
**US-A- 6 091 033**

**EP 1 406 277 B1**

Note: Within nine months of the publication of the mention of the grant of the European patent in the European Patent Bulletin, any person may give notice to the European Patent Office of opposition to that patent, in accordance with the Implementing Regulations. Notice of opposition shall not be deemed to have been filed until the opposition fee has been paid. (Art. 99(1) European Patent Convention).

## Description

### BACKGROUND OF THE INVENTION

**[0001]** The present invention relates to a rotary switch device in which a structure of contacting a movable contact with a fixed contact and separating the movable contact from the fixed contact is improved.

**[0002]** Concerning the rotary switch device used for various control of a vehicle, there is conventionally provided a rotary switch device shown in Fig. 8. This rotary switch device is composed as follows. In the knob 1 to be rotated for operation, there is provided a gear 2. The gear 2 is meshed with a gear 3. A holder support 4 is attached to this gear 3, and a contact holder 5 is attached to this holder support 4. This structure is disclosed, for example, in JP-A-10-269898. Movable contacts 6 are attached to the contact holder 5. Fixed contacts 7 to 9 corresponding to the movable contacts 6 are provided on a base plate 10. Fig. 9 is a view showing an arrangement of the fixed contacts 7 to 9 on the base plate 10 in detail.

**[0003]** When the knob 1 is rotated in this constitution, as respectively shown by arrows in Fig. 8, the gear 2 is integrally rotated with the knob 1, and the gear 3 meshed with the gear 2 is rotated. Then, the holder support 4 is integrally rotated with the gear 3, and the contact holder 5 is integrally rotated with the holder support 4. As a result, the movable contacts 6 slide on portions where the fixed contacts 7 to 9 are located, so that the movable contacts 6 can be contacted with and separated from the fixed contacts 7 to 9.

**[0004]** In Fig. 9, black points show the contacting points at which the movable contacts 6 come into contact with the fixed contacts 7 to 9. In the first operation stage A of the knob 1, the movable contact 6 comes into contact with the fixed contacts 7 and 8, so that the fixed contacts 7 and 8 can be connected with each other. Successively, in the operation state B, the movable contact 6 comes into contact with the fixed contacts 7, 8 and 9, so that the fixed contacts 7, 8 and 9 can be connected with each other. Successively, in the operation state C, the movable contact 6 comes into contact with the fixed contacts 7 and 9, so that the fixed contacts 7 and 9 can be connected with each other. Successively, in the operation state D, the movable contact 6 comes into contact with only the fixed contact 7, that is, the movable contact 6 does not come into contact with the other fixed contacts 8 and 9.

**[0005]** In the operation stages E to H of the knob 1, operation is conducted in the same manner as that of the above operation stages A to D. Further, even after the knob 1 has been rotated by one revolution, the same operation is endlessly conducted in the operation stages A to H. Fig. 10 is a table on which the above operation is shown.

**[0006]** In the case of the above conventional rotary switch device, it is necessary to concentrically arrange the fixed contacts 7 to 9 on the base plate 10 in accordance with the movement of the movable contacts 6 which

are moved by the rotation of the contact holder 5. The fixed contacts 7 to 9, which are arranged in an arcuate swelling space (that is, the width of which is wide), must be arranged on the base plate 10, the space of which is limited. Therefore, the fixed contacts 7 to 9 are necessarily arranged compactly.

**[0007]** For the above reasons, an operation stroke of the movable contact 6 must be reduced. Therefore, this structure has the following disadvantages. In this structure, the accuracy of switching is greatly affected by the accuracy of meshing of the gear 2 with the gear 3 and the positional deviation of the movable contact 6. Therefore, the actual thing must be manufactured with considerably high accuracy. Unless the actual thing is manufactured with considerably high accuracy, the reliability of the product is lowered.

**[0008]** Document DE-C-19722780 discloses a rotary switch according to the preamble of claim 1.

### SUMMARY OF THE INVENTION

**[0009]** The present invention has been accomplished in view of the above circumstances. It is an object of the present invention to provide a rotary switch device, the reliability with respect to the switching accuracy of which is high even when the actual thing is not manufactured with considerably high accuracy.

**[0010]** In order to accomplish the above object, the present invention provides a rotary switch device according to claim 1.

**[0011]** According to the above structure, although the knob is operated by rotation, all movable contacts are linearly reciprocated. Corresponding to the linear movements of the movable contacts, the fixed contacts are linearly arranged. Therefore, the sufficiently large fixed contacts can be arranged even in a limited space. Accordingly, it is possible to extend an operation stroke of each movable contact. There is no possibility that the switching accuracy is greatly affected by the assembling accuracy of the other parts and the positional deviation of the movable contacts. Consequently, it is unnecessary to manufacture the actual thing with considerably high accuracy. Therefore, high reliability can be provided.

### BRIEF DESCRIPTION OF THE DRAWINGS

#### **[0012]**

Fig. 1 is an exploded perspective view of a primary portion of an embodiment of the present invention.

Fig. 2 is an external appearance perspective view of an operation lever into which the present rotary switch device is incorporated.

Fig. 3 is a first lower face view showing an action of the primary portion.

Fig. 4 is a second lower face view showing an action of the primary portion.

Fig. 5 is a third lower face view showing an action of

the primary portion.

Fig. 6 is a fourth lower face view showing an action of the primary portion.

Fig. 7 is a view showing a table on which an action of the primary portion is expressed.

Fig. 8 is a view corresponding to Fig. 1 showing a conventional example.

Fig. 9 is a lower face view showing an action of the primary portion of the conventional example of figure 8.

Fig. 10 is a view showing an operation table of the conventional rotary switch.

#### DETAILED DESCRIPTION OF PREFERRED EMBODIMENTS

**[0013]** Referring to Figs. 1 to 7, an embodiment will be explained below in which the present invention is applied to a rotary switch device for vehicle use.

First, in Fig. 2, reference numeral 11 is an operation lever, for example, arranged in a portion close to a steering wheel of a vehicle. Various parts shown in Fig. 1 are incorporated into the operation lever 11.

**[0014]** In the operation lever 11, reference numeral 12 is a knob, which is formed into a short cylinder having a lid. One guide piece 13 is incorporated into the knob 12. This one guide piece 13 is formed into a short cylinder, the diameter of which is smaller than that of the knob 12, and provided with an internal cylinder 14 inside. This internal cylinder 14 has a wave-shaped portion 15 on the side opposite to the inner side of the knob 12 (on the right in the drawing). Each wave-form of the wave-form portion 15 is trapezoidal. In this connection, this one guide piece 13 may be integrally formed with the knob 12.

**[0015]** On the other hand, reference numeral 16 is the other guide piece which forms a pair together with one guide piece 13 described above. The other guide piece 16 is formed into a ring-shape and provided with a wave-shaped portion 17 on the guide piece 13 side. Shape of the wave-shaped portion 17 is constituted by a plurality of trapezoids. This other guide piece 16 is incorporated into one guide piece 13. As a result of this incorporation, the wave-shaped portion 17 is opposed to the wave-shaped portion 15. A gap formed between the wave-shaped portion 17 and the wave-shaped portion 15 forms a guide portion 18 composed of a wave-shaped groove.

**[0016]** Reference numerals 19 and 20 are contact holders. Both contact holders 19 and 20 respectively have protrusions 21 and 22, which are inserted into the aforementioned guide portion 18. On the sides of the contact holders 19 and 20 opposite to the side on which the protrusions 21 and 22 are arranged, the movable contacts 23 and 24 are attached. At the forward end portions of these movable contacts 23 and 24, there are provided contacts 23a, 23b, 24a, 24b shown in Figs. 3 to 6. Although not shown in the drawing, traverse movements of these contact holds 19, 20 are restricted by some structure arranged in the operation lever 11.

**[0017]** Reference numeral 25 is a base plate. On the lower face of this base plate 25, there are provided fixed contacts 26, 27, 28. These fixed contacts 26, 27, 28 correspond to the movable contacts 23, 24. In these fixed contacts, the fixed contact 26 is formed into a crank-shape. On the other hand, both the fixed contacts 27, 28 are respectively formed into a simple rectangle.

**[0018]** As described before, these parts are incorporated into the operation lever 11, however, as shown in Fig. 2, one portion of the knob 11 is exposed outside from the window portion 29 of the operation lever 11, so that the knob 11 can be rotated by operation.

**[0019]** Next, operation of the above rotary switch will be explained below.

When the knob 12 is rotated by operation, as shown by arrows in Fig. 1, one guide piece 13 and the other guide piece 16 are integrally rotated with the knob 12, and the guide portion 1 is also rotated. The protrusions 21, 22 of the contact holders 19, 20 are respectively inserted into the rotating guide portion 18. Further, since the movements of the contact holders 19, 20 in the traverse direction are restricted by some structure arranged in the operation lever 11, the contact holders 19, 20 are individually, linearly reciprocated by the protrusions 21, 22 following ups and downs of the waveshape of the guide portion 18. Accordingly, the movable contacts 23, 24 are individually, linearly reciprocated integrally with the protrusions 21, 22. Therefore, the movable contacts 23, 24 slide on the fixed contacts 26, 27, 28 arranged below the base plate 25. In this way, the movable contacts 23, 24 are contacted with and separated from the fixed contacts 26, 27, 28.

**[0020]** Figs. 3 to 6 are views showing the displacement of the movable contacts 23, 24 (the displacement of the contact holders 19, 20) in the order of operation of the knob 12. In the initial operation stage A of the knob 12 shown in Fig. 3, the movable contact 23 makes the contact 23a come into contact with the fixed contact 26. At the same time, the movable contact 23 makes the contact 23b come into contact with the fixed contact 27. Due to this contacting operation, the fixed contacts 26 and 27 are connected with each other. In this connection, at this time, the movable contact 24 makes the contact 24a come into contact with the fixed contact 26, however, the contact 24b is not contacted with the fixed contact 28. Therefore, these fixed contacts 26 and 28 are not connected with each other.

**[0021]** Successively, in the operation stage B shown in Fig. 4, the movable contact 23 makes the contact 23a come into contact with the fixed contact 26 and also makes the contact 23b come into contact with the fixed contact 27. Due to this switching operation, these fixed contacts 26 and 27 are connected with each other. In this connection, at this time, the movable contact 24 makes the contact 24a come into contact with the fixed contact 26, and at the same time, the contact 24b is contacted with the fixed contact 28. Therefore, these fixed contacts 26 and 28 are connected with each other.

**[0022]** Successively, in the operation stage C shown in Fig. 5, the movable contact 23 makes the contact 23a come into contact with the fixed contact 26, however, the movable contact 23 does not make the contact 23b come into contact with the fixed contact 27. Therefore, these fixed contacts 26 and 27 are not connected with each other. However, at this time, the movable contact 24 makes the contact 24a come into contact with the fixed contact 26 and also makes the contact 24b come into contact with the fixed contact 28. Due to this switching operation, these fixed contacts 26 and 28 are connected with each other.

**[0023]** Successively, in the operation stage D shown in Fig. 6, the movable contact 23 makes the contact 23a come into contact with the fixed contact 26, however, the movable contact 23 does not make the contact 23b come into contact with the fixed contact 27. Therefore, these fixed contacts 26 and 27 are not connected with each other. At this time, the movable contact 24 makes the contact 24a come into contact with the fixed contact 26. However, the movable contact 24 does not make the contact 24b come into contact with the fixed contact 28. Therefore, these fixed contacts 26 and 28 are connected with each other.

After one revolution has been completed, the same operation as that described above is endlessly repeated in the operation stages A to D. This repetition is shown on the table of Fig. 7.

**[0024]** In the constitution described above, a different state of connection of the movable contacts 23, 24 with the fixed contacts 26 to 28 is successively realized by a linear reciprocating motion of the plurality of individual contact holders 19, 20 according to the rotation of the knob 12.

**[0025]** According to the above structure, although the knob 12 is operated by rotation, all movable contacts 23, 24 are linearly reciprocated. Corresponding to the linear movements of the movable contacts 23, 24, the fixed contacts 26 to 28 are linearly arranged not being swollen. Therefore, the sufficiently large fixed contacts can be arranged even in a limited space (especially, in a space, the width of which is limited) such as a space on the lower face of the base plate 25. Accordingly, it is possible to extend an operation stroke of each movable contact 23, 24. There is no possibility that the switching accuracy is greatly affected by the assembling accuracy of the other parts and the positional deviation of the movable contacts. Consequently, it is unnecessary to manufacture the actual thing with considerably high accuracy. Therefore, high reliability can be provided.

**[0026]** In this connection, the present invention is not limited to the above specific embodiment shown in the accompanying drawings. Especially, the present invention may be applied to a case in which the numbers of the movable and the fixed contacts are not less than the aforementioned numbers. Further, the rotary switch device of the invention can be used for not only vehicles but also the other apparatus. Furthermore, the rotary

switch device of the invention is not limited to the use of incorporating it into an operation lever. That is, variations may be made without departing from the scope of the appended claims.

**[0027]** As explained above, according to the rotary switch device of the present invention, even when the actual thing is not manufactured with considerably high accuracy, it is possible to provide a rotary switch device, the switching accuracy of which is highly reliable.

## Claims

1. A rotary switch device comprising:

a knob (12) to be rotated for operation;  
 a wave-shaped guide portion (18) provided in the knob (12) in a rotary direction;  
 a plurality of protrusions (21, 22) belonging to contact holders (19, 20), the protrusions (21, 22) being provided in the guide portion (18), which can be individually, linearly reciprocated in accordance with the rotation of the knob (12);  
 a plurality of movable contacts (23, 24) respectively provided in the contact holders (19, 20);  
 a plurality of fixed contacts (26, 27, 28) adapted to be in contact with and separated from the movable contacts (23, 24),

wherein a different state of connection of the movable contacts (23, 24) with the fixed contacts (26, 27, 28) is successively realized by a linear reciprocating motion of the plurality of individual contact holders (19, 20) according to the rotation of the knob (12),

### characterized in that

the guide portion (18) has an annular shape in which a wave-shaped groove is provided in the knob (12) in the rotary direction so that the knob (12) can be endlessly rotated in the rotary direction.

2. The rotary switch device according to claim 1, wherein shape of the guide portion (18) is constituted by a plurality of trapezoids.

3. The rotary switch device according to claim 1, wherein the protrusion (21, 22) is projected from one side of the contact holder (19, 20) and inserted into the guide portion (18), and the movable contact (23, 24) is attached to the other side of the contact holder (19, 20).

## Patentansprüche

1. Drehschaltevorrichtung, die umfasst:

einen Knopf (12), der zum Betätigen gedreht

wird;  
 einen wellenförmigen Führungsabschnitt (18),  
 der in dem Knopf (12) in einer Drehrichtung vor-  
 handen ist;  
 eine Vielzahl von Vorsprüngen (21, 22), die zu  
 5 Kontakthaltern (19, 20) gehören, wobei die Vor-  
 sprünge (21, 22) in dem Führungsabschnitt (18)  
 vorhanden sind und sie entsprechend der Dre-  
 hung des Knopfes (12) einzeln linear hin- und  
 10 herbewegt werden können;  
 eine Vielzahl beweglicher Kontakte (23, 24), die  
 jeweils in den Kontakthaltern (19, 20) vorhanden  
 sind;  
 eine Vielzahl unbeweglicher Kontakte (26, 27,  
 28), die so eingerichtet sind, dass sie mit den  
 15 beweglichen Kontakten (23, 24) in Kontakt kom-  
 men und von ihnen getrennt werden,  
 wobei ein anderer Verbindungszustand der be-  
 weglichen Kontakte (23, 24) mit den unbeweg-  
 lichen Kontakten (26, 27, 28) anschließend mit-  
 20 tels einer linearen Hin- und Herbewegung der  
 Vielzahl einzelner Kontakthalter (19, 20) ent-  
 sprechend der Drehung des Knopfes (12) her-  
 gestellt wird,

**dadurch gekennzeichnet, dass**

der Führungsabschnitt (18) eine Ringform hat,  
 bei der in dem Knopf (12) eine wellenförmige  
 Nut in der Drehrichtung vorhanden ist, so dass  
 der Knopf (12) endlos in der Drehrichtung ge-  
 dreht werden kann.

2. Drehschaltvorrichtung nach Anspruch 1, wobei die  
 Form des Führungsabschnitts (18) durch eine Viel-  
 zahl von Trapezoiden gebildet wird. 35
3. Drehschaltvorrichtung nach Anspruch 1, wobei  
 der Vorsprung (21, 22) von einer Seite des Kontakt-  
 halters (19, 20) vorsteht und in den Führungsab-  
 schnitt (18) eingeführt ist und der bewegliche Kon-  
 40 takt (23, 24) an der anderen Seite des Kontakthalters  
 (19, 20) angebracht ist.

**Revendications**

1. Dispositif de commutateur tournant comprenant :

un bouton (12) fonctionnant en étant mis en  
 rotation ;  
 une partie de guidage de forme ondulée (18) 50  
 placée dans le bouton (12) dans une direction  
 de rotation ;  
 une pluralité de saillies (21, 22) appartenant à  
 des supports de contact (19, 20), les saillies (21,  
 22) étant placées dans la partie de guidage (18), 55  
 qui peuvent être actionnées individuellement, li-  
 néairement en va-et-vient avec la rotation du  
 bouton (12) ;

une pluralité de contacts mobiles (23, 24) placés  
 respectivement dans les supports de contact  
 (19, 20) ;

une pluralité de contacts fixes (26, 27, 28) adap-  
 tés pour être en contact avec et séparés des  
 contacts mobiles (23, 24),  
 dans lequel un état différent de connexion des  
 contacts mobiles (23, 24) avec les contacts fixes  
 (26, 27, 28) est réalisé successivement par un  
 mouvement de va-et-vient linéaire de la pluralité  
 de supports de contact (19, 20) individuels en  
 fonction de la rotation du bouton (12),

**caractérisé en ce que**

la partie de guidage (18) a une forme annulaire  
 dans lequel une rainure de forme ondulée est  
 placée dans le bouton (12) dans la direction de  
 rotation de telle manière que le bouton (12) peut  
 être tourné sans fin dans la direction de rotation.

2. Dispositif de commutateur tournant selon la reven-  
 dication 1, dans lequel la forme de la partie de gui-  
 dage (18) est constituée d'une pluralité de trapèzes.
3. Dispositif de commutateur tournant selon la reven-  
 dication 1, dans lequel la saillie (21, 22) fait saillie  
 depuis un côté du support de contact (19, 20) et est  
 insérée dans la partie de guidage (18), et le contact  
 mobile (23, 24) est fixé sur l'autre côté du support  
 de contact (19, 20).



FIG. 2

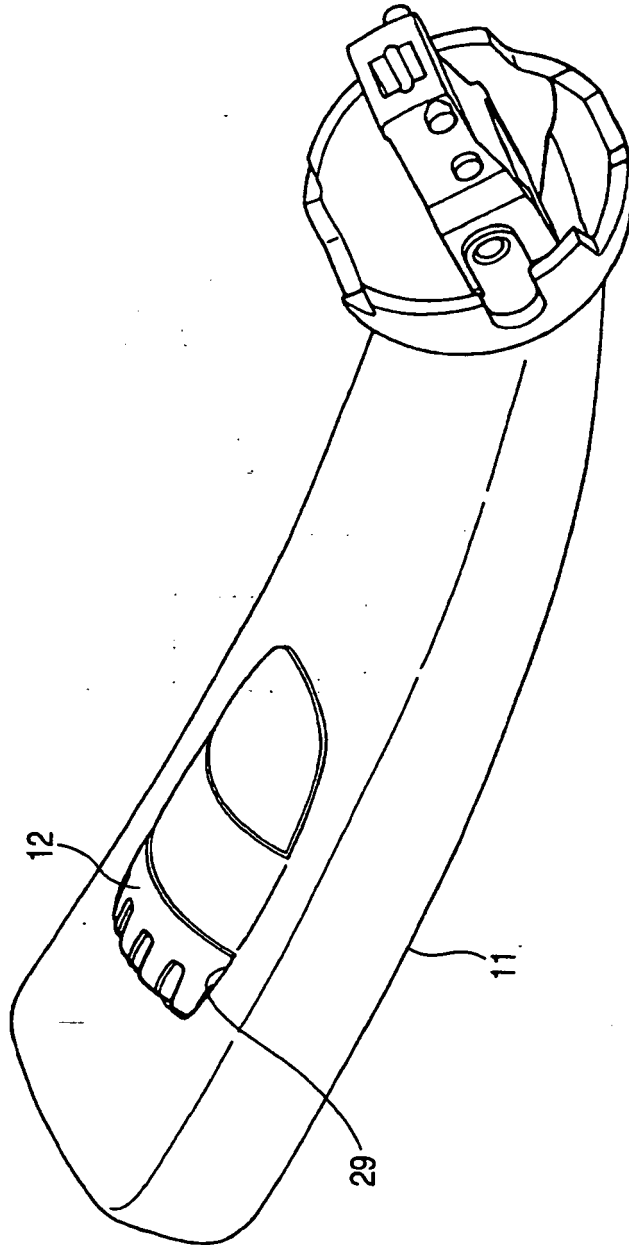

FIG. 3

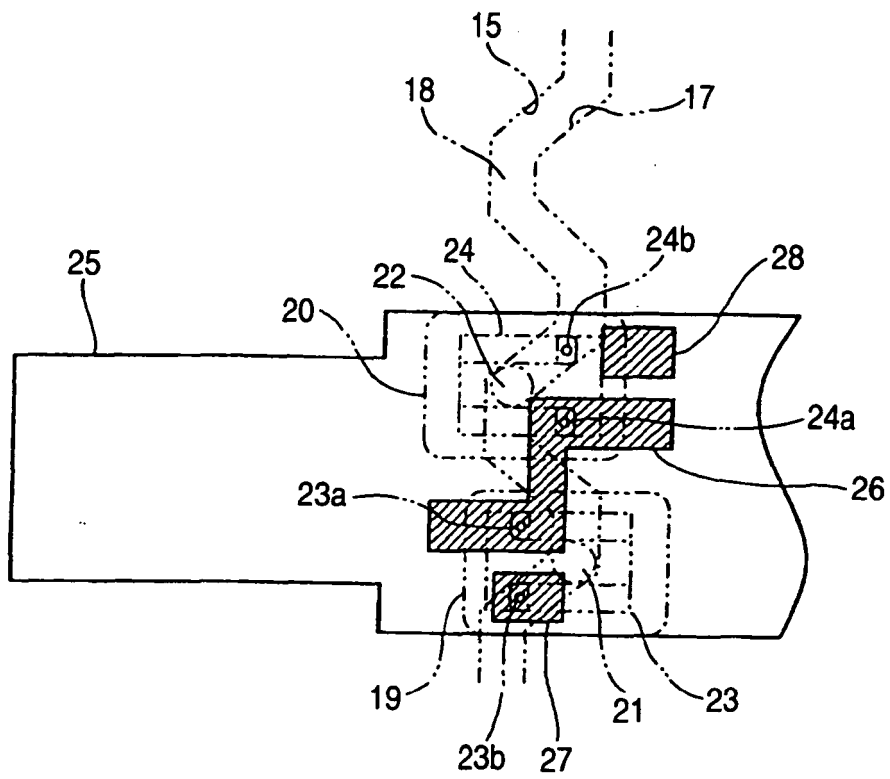

FIG. 4

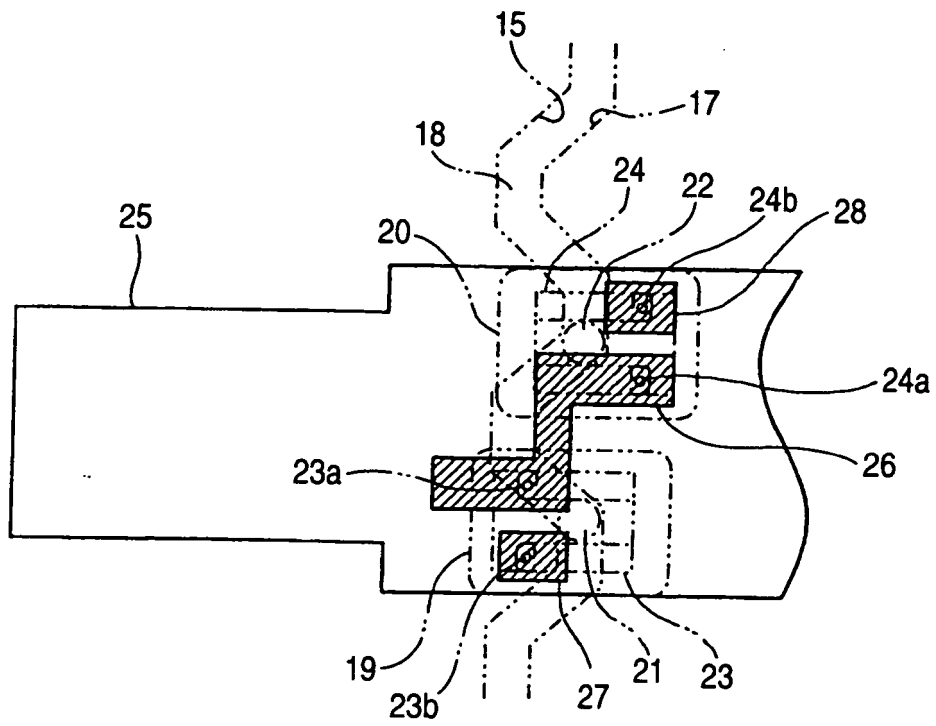

FIG. 5

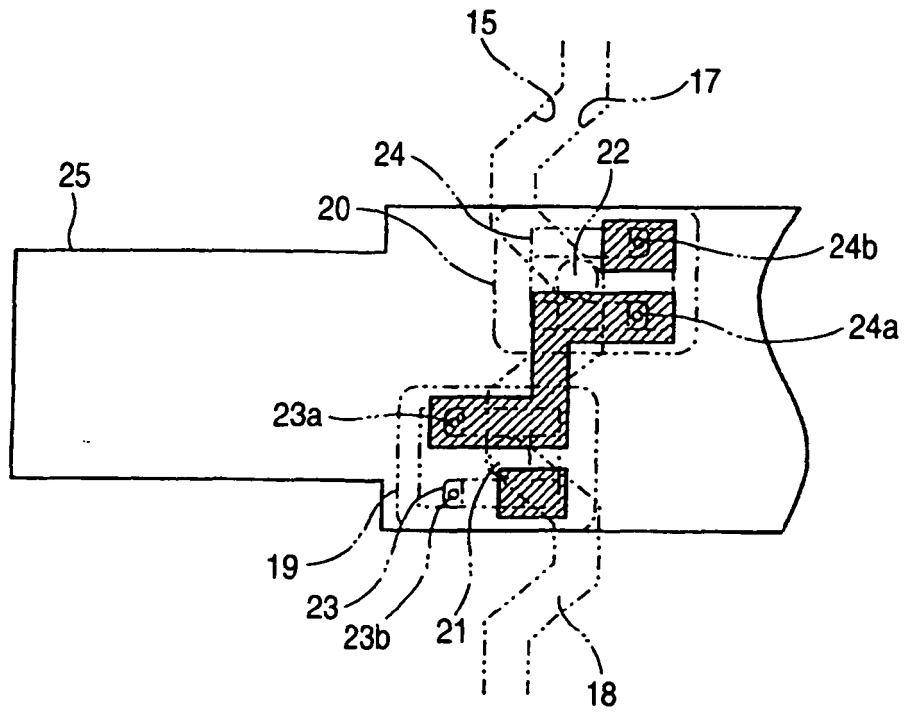

FIG. 6

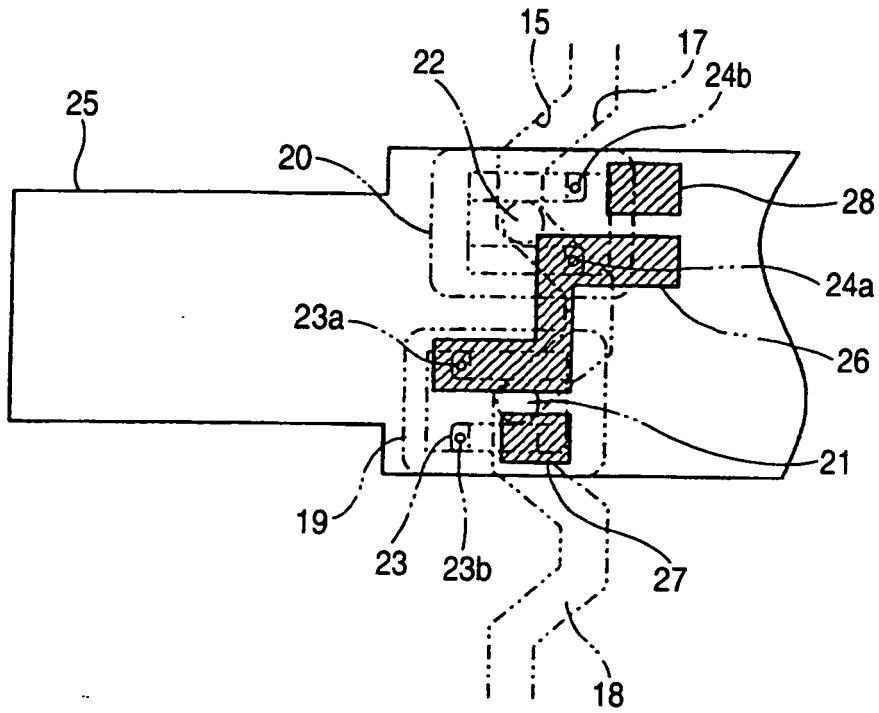

FIG. 7

	27	26	28
A	○ — ○	○	
B	○ — ○	○ — ○	○
C		○ — ○	○
D		○	

FIG. 8

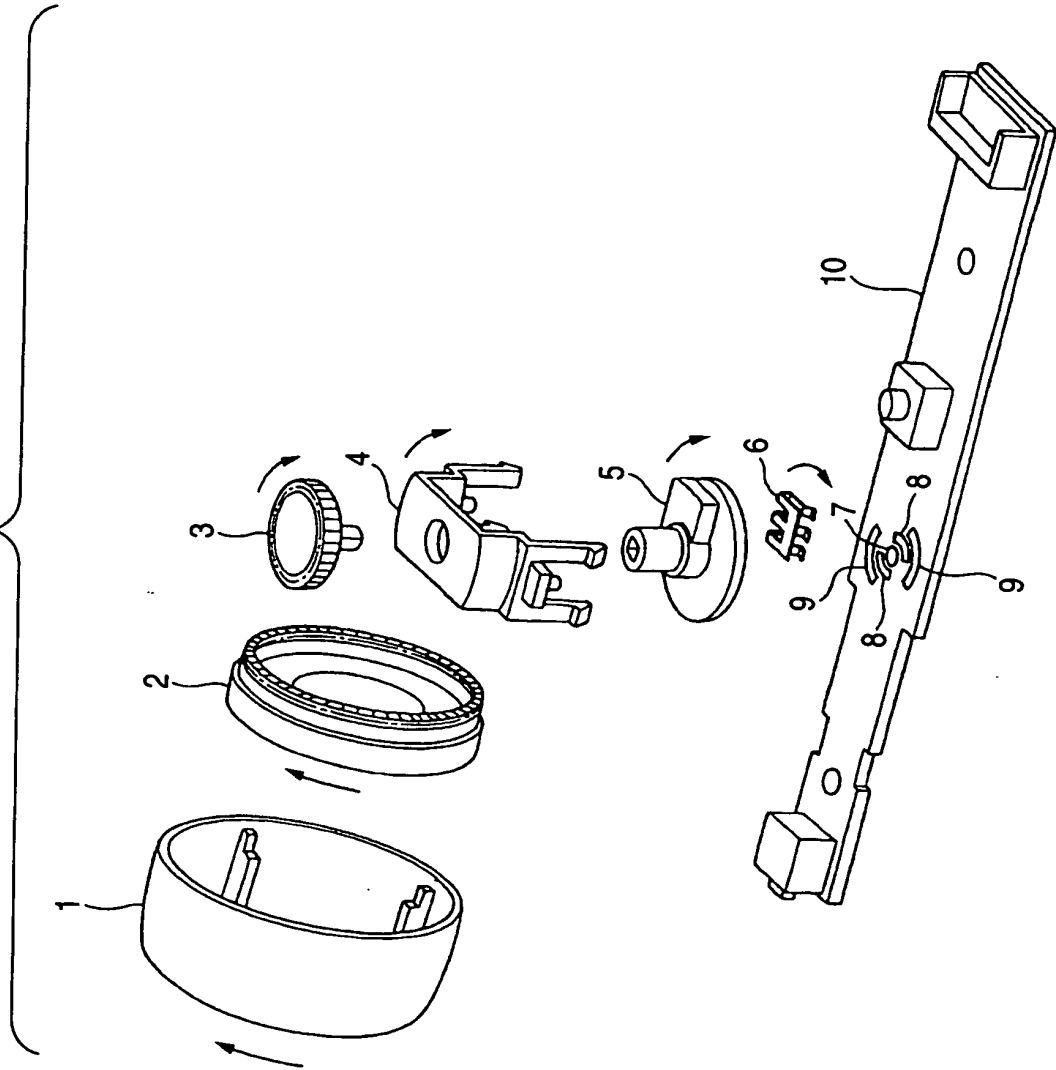
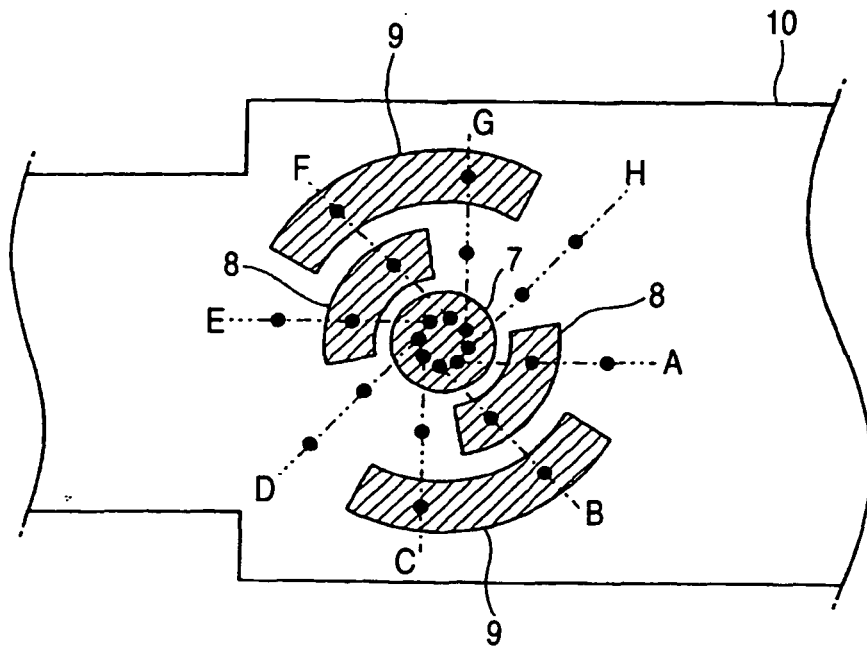

FIG. 9



*FIG. 10*

	7	8	9
A	○	○	
B	○	○	○
C	○		○
D	○		
E	○	○	
F	○	○	○
G	○		○
H	○		

**REFERENCES CITED IN THE DESCRIPTION**

*This list of references cited by the applicant is for the reader's convenience only. It does not form part of the European patent document. Even though great care has been taken in compiling the references, errors or omissions cannot be excluded and the EPO disclaims all liability in this regard.*

**Patent documents cited in the description**

- JP 10269898 A [0002]
- DE 19722780 C [0008]