

Sept. 2, 1969

M. RAPPAPORT

3,464,130

PRESSING APPARATUS

Filed Feb. 17, 1967

3 Sheets-Sheet 1

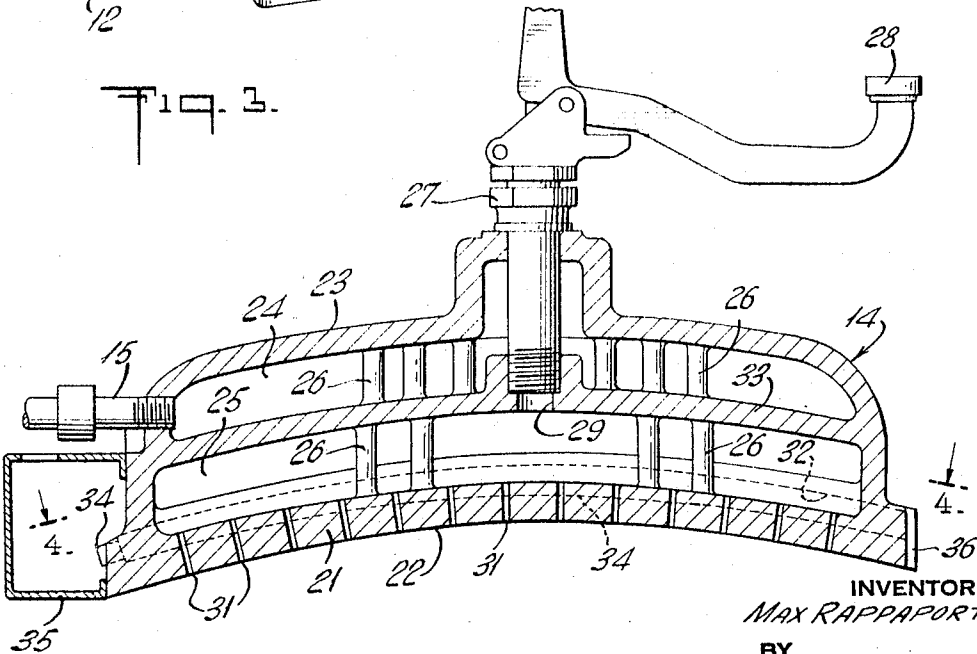
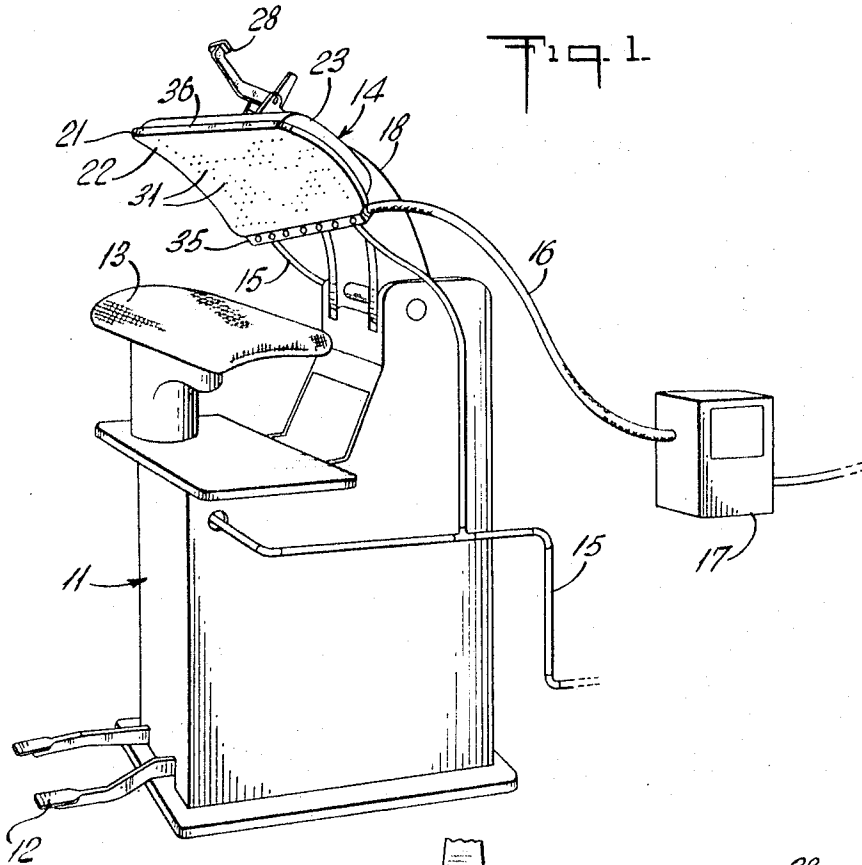

INVENTOR
MAX RAPPAPORT

BY

Blum, Mscowitz, Friedman, Blum, & Kaplan
ATTORNEYS

Sept. 2, 1969

M. RAPPAPORT
PRESSING APPARATUS

3,464,130

Filed Feb. 17, 1967

3 Sheets-Sheet 2

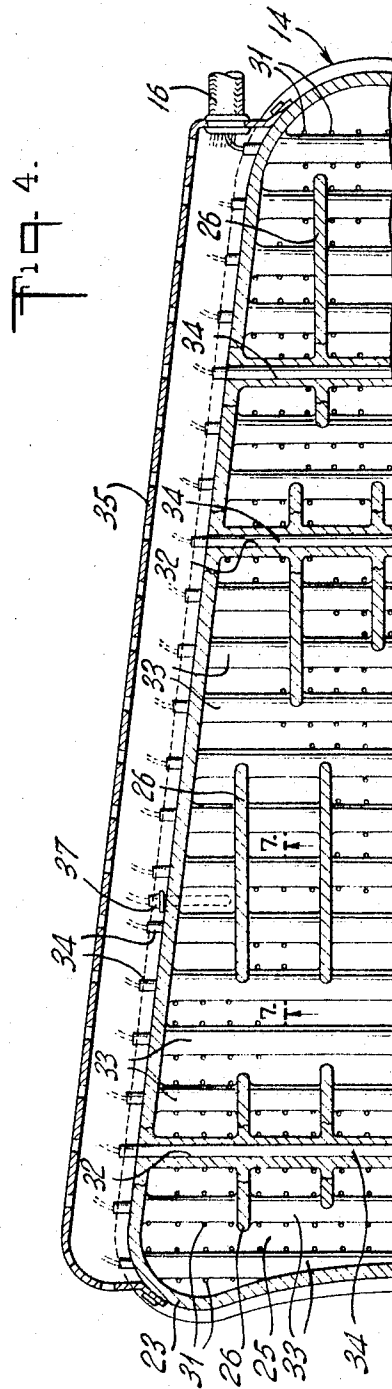
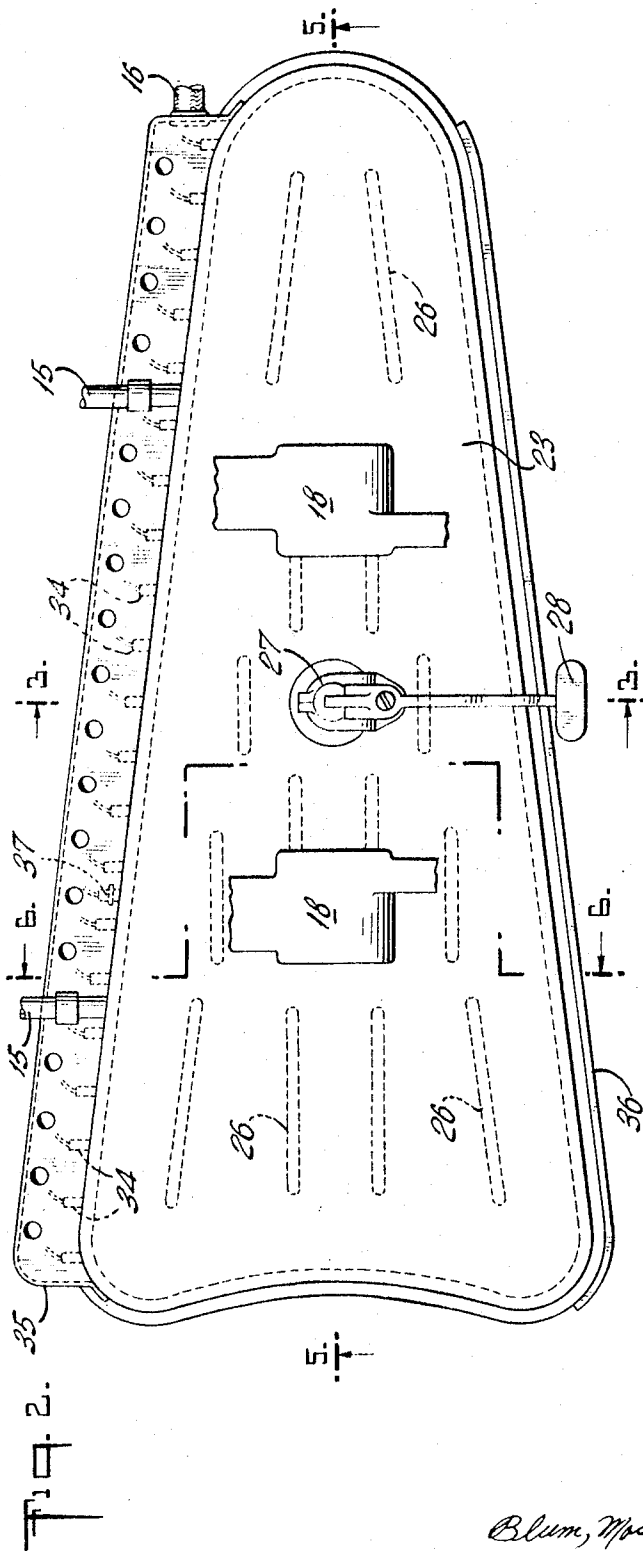

INVENTOR
MAX RAPPAPORT

BY

Blum, Moscovitz, Friedman, Blum, & Kaplan
ATTORNEYS

Sept. 2, 1969

M. RAPPAPORT
PRESSING APPARATUS

3,464,130

Filed Feb. 17, 1967

3 Sheets-Sheet 3

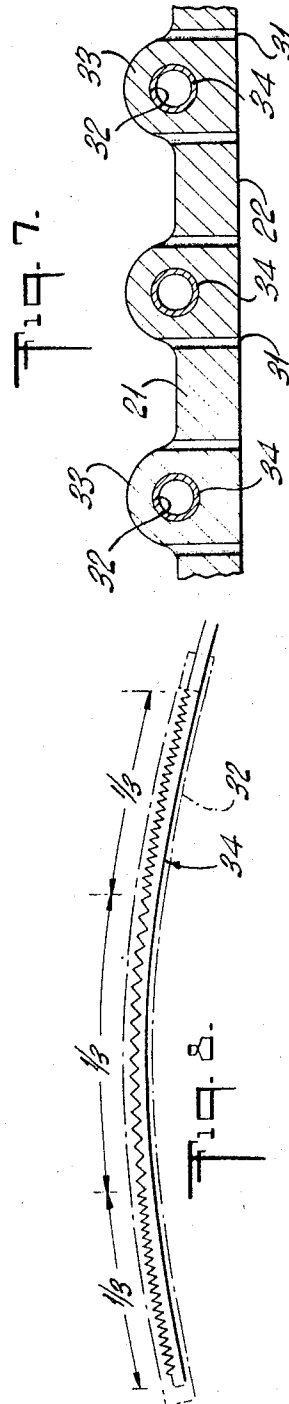
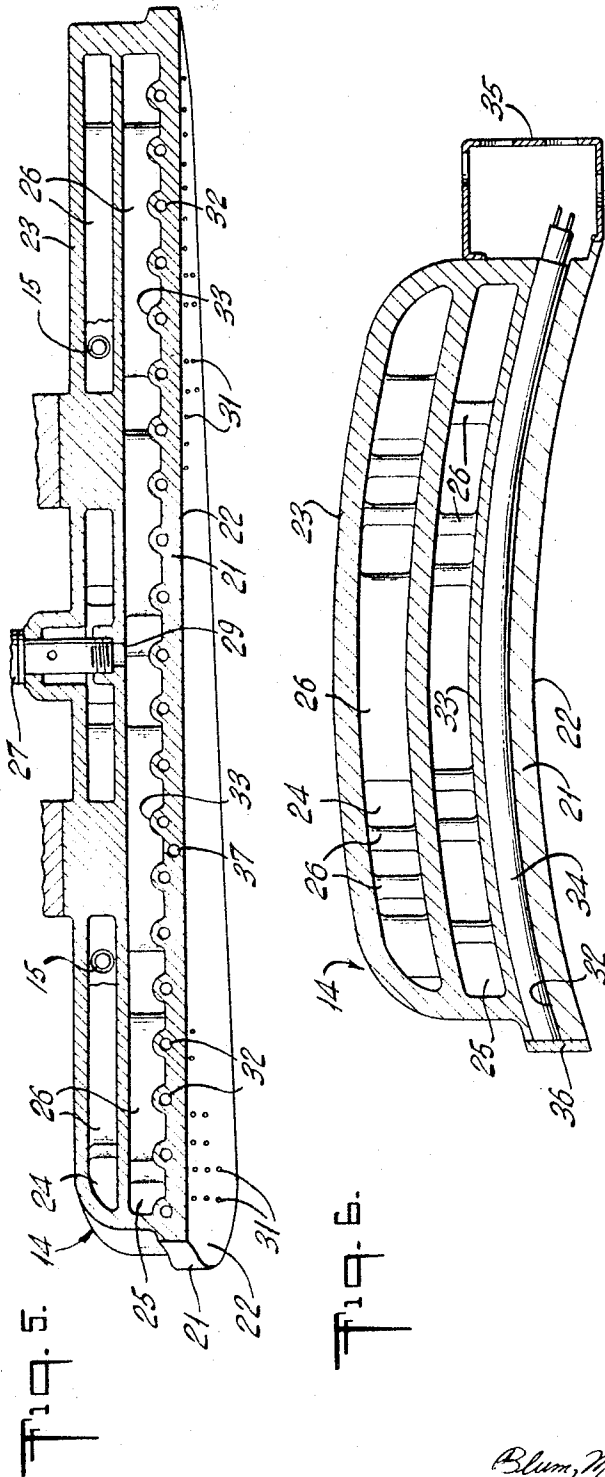

INVENTOR
MAX RAPPAPORT

BY

Blum, Masovitz, Friedman, Blum & Kaplan
ATTORNEYS

1

3,464,130

PRESSING APPARATUS

Max Rappaport, River Edge, N.J., assignor to New York Pressing Machinery Corporation, Paterson, N.J., a corporation of New York

Filed Feb. 17, 1967, Ser. No. 616,811

Int. Cl. D06f 71/34

U.S. Cl. 38—15

4 Claims

ABSTRACT OF THE DISCLOSURE

A head for a pressing machine which has a relatively thick head plate and heaters mounted within the plate for the heating of the plate. Wet steam passes through apertures in the plate and the location of the heaters within the plate reduces the drying effect of the heaters on the steam.

Background of the invention

This invention relates generally to pressing apparatus and more particularly to an improved form of pressing head wherein the heating of the head does not cause a drying out of the steam passing therethrough.

In prior pressing apparatus, it has been known to heat the pressing head by means of a plurality of heaters located in steam chambers in the head. In order to heat the pressing surface of the head, it was necessary to raise the heaters to a substantially high temperature and steam passing through the head impinged on the heaters and was raised, at least locally, to a higher temperature which caused a drying out of the steam. In pressing, better results are obtained by pressing with steam having a high moisture content (wet steam). Thus the drying out of the steam by the head heaters was undesirable.

Summary of the invention

Generally speaking, in accordance with the invention, the head of a pressing apparatus is constructed with a pressing plate of relatively large mass to provide a heat sink for rapid conduction of heat therethrough. A plurality of heaters are mounted wholly within the plate in order to separate the steam chamber from the heater elements.

Accordingly, a principal object of the invention is to provide a pressing apparatus and particularly a pressing head which will have a heated pressing surface and which will not contribute substantially to the drying of steam delivered therethrough.

Another object of the invention is to provide a pressing head plate of relatively large mass which will act as a heat sink with good conductivity in order to provide improved uniformity in heating of the head plate.

Still another object of the invention is to provide a head plate within which is mounted heating elements whereby steam impinges on the head plate only and not on the heating elements.

Still other objects and advantages of the invention will in part be obvious and will in part be apparent from the specification.

The invention accordingly comprises the features of construction, combination of elements, and arrangement of parts which will be exemplified in the construction hereinafter set forth, and the scope of the invention will be indicated in the claims.

Brief description of the drawings

For a fuller understanding of the invention, reference is had to the following description taken in connection with the accompanying drawings, in which:

FIG. 1 is a perspective pictorial view of any suitable pressing apparatus having a head constructed in accordance with the invention incorporated therein;

2

FIG. 2 is a top plan view of a pressing head constructed in accordance with a preferred embodiment of the instant invention;

FIG. 3 is a sectional view taken along line 3—3 of FIG. 2;

FIG. 4 is a partial sectional view taken along line 4—4 of FIG. 3;

FIG. 5 is a sectional view taken along line 5—5 of FIG. 2;

FIG. 6 is a sectional view taken along line 6—6 of FIG. 2;

FIG. 7 is a partial sectional view, at an enlarged scale, taken along line 7—7 of FIG. 4; and

FIG. 8 is an enlarged view of the construction of an embodiment of the heater element.

Description of the preferred embodiment

A pressing machine is indicated generally at 11 in FIG. 1 having controls 12, a buck 13, a pressing head 14, steam lines 15, an electrical input line 16 and an electrical control box 17. It will be understood that the pressing machine is shown generally for environmental purposes only since the invention may be incorporated in any type of pressing machine. The invention more particularly relates to the construction of pressing head 14 which is pivoted by means of arms 18 for rotation into closed contact with the surface of buck 13. The pressing head includes a pressing plate 21 with one surface thereof being the pressing surface 22.

Referring more particularly to FIGS. 2 through 7, pressing head 14 is fabricated to provide a housing 23 above pressing plate 21 defining an upper chamber 24 and a lower chamber 25 with a plurality of baffles 26 being located at spaced intervals within each of the upper and lower chambers. Steam lines 15 are connected to housing 23 in communication with upper chamber 24. A suitable valve 27 of any known construction having a control handle 28 is carried by housing 23 to control communication of upper chamber 24 with lower chamber 25 through a passage 29.

As hereinabove described, pressing plate 21 has an outer pressing surface 22 of any known configuration depending on the particular pressing machine and the configuration of the buck. Pressing plate 21 defines the lower plate of lower chamber 25 and a plurality of steam openings 31 extend through the pressing plate and communicate with the lower chamber. A number of steam openings are shown in FIG. 4 and the steam openings are generally spaced at intervals throughout the entire pressing surface to assure the delivery of steam to the garment being pressed during the pressing operation. As will be apparent, steam is delivered to the pressing head through the steam lines and fills upper chamber 24. On actuation of valve 27 by control handle 28, the steam under pressure in the upper chamber is delivered to the lower chamber and thereupon passes outwardly through steam openings 31.

As shown at an enlarged scale in FIG. 7, pressing plate 21, which is normally fabricated of cast metal, is relatively thick as compared with prior art pressing plates with the preferred thickness being about 1.5" which is approximately four times the thickness of prior art pressing plates. By the substantial increase in thickness and mass of the pressing plate, a substantial increase in heat conductivity results with the mass of the pressing plate acting as a heat sink for retention of heat energy.

The pressing plate is provided with a plurality of transverse passages 32 to receive heating elements to be subsequently described. As shown in FIG. 7, each transverse passage is wholly within the pressing plate and surrounded, at the upper portion thereof, by a relatively thick arcuate portion 33 which is formed as an integral

part of the pressing plate and which extends into lower chamber 25. By provision of the arcuate portion 33, the mass of the pressing plate within the area of each transverse passage is not materially changed as respects the mass of the plate at areas not having a transverse passage.

Within each transverse passage 32 is located a heating unit 34 of the electrical resistance type for heating of the pressing plate. The heating units may be of the type known commercially as Chromalox heating units which have a degree of flexibility to allow insertion of same in the transverse passages. The heating units are connected, by any suitable means, to a power source through electrical input line 16 and electrical control box 17. A suitable cover 35 removably secured to the rear side of pressing head 14 is provided for covering the terminal ends of the heating units, and a suitable cover 36 is provided at the front side of the pressing head for closing the open ends of transverse passages 32.

As noted hereinbefore, the heater elements are electrically connected to the power source through electrical input line 16 and control box 17. Since it is desired to accurately control the temperature of the pressing plate and pressing surface, means of sensing the temperature and controlling input through the electrical control box is provided in the form of a thermistor 37 mounted within pressing plate 21 and secured therein by a thermally conductive adhesive. As is known in the art, the resistance of a thermistor varies with changes in temperature thereby making the device temperature sensitive. By suitable circuitry (not shown) the heating of the elements are controlled in response to changes in temperature sensed by the thermistor.

The general operation of the foregoing apparatus may now be described. It has been found that a surface temperature of the pressing plate up to about 450° F. is most desirable for certain pressing operations and it is naturally desirable that the temperature be uniform throughout the pressing surface with temperature variations being preferably in the range of $\pm 5^\circ$ of the selected temperature as determined by control 17. In order to do this in the prior art with heating elements located within the lower chamber, the heating of the elements to extremely high temperatures was required since the heating of the pressing plate was accomplished primarily by radiation. In the instant invention with a substantial number of heating elements being provided at spacings of approximately 2" with the heating elements being located wholly within the pressing plate, the heat loss is minimized and heat is transferred to the plate by conduction and throughout the plate as a result of the large mass of the plate which acts as a heat sink and which therefore has a high degree of thermal conductivity. Even though the temperature of the heating elements must be above the optimum plate temperature in order to maintain the temperature at the desired level during the constant heat loss from the pressing surface and the housing generally, the construction permits lower heating element temperatures than was heretofore possible.

Of equal importance is the separation of the heating elements from the steam. Wet steam is supplied through steam lines 15 at a maximum pressure of approximately 125 p.s.i. and a temperature of approximately 340° F. to upper chamber 24. On actuation of valve 27 the steam passes into the lower chamber and thence through steam openings 31 in the usual fashion. In the prior art with the heating elements located within the lower chamber, the steam at a temperature of approximately 340° F. impinged directly on the high temperature heating elements causing a sudden heating of the steam effecting a drying out of the steam. This result is undesirable since wet steam is preferred for the pressing operation. By locating the heating elements wholly within the pressing plate two immediate and substantial benefits occur. Firstly, the absolute temperature of the heating elements may be reduced and secondly, the heating elements are removed

from direct contact with the steam, the steam coming into engagement only with the top surface of the pressing plate which naturally will be at a lower temperature than the heating elements. Thus, while the pressing plate may be at a temperature somewhat above the temperature of the steam supplied, it is substantially lower than the temperature of the heating elements in prior art devices and thus the substantial drying of the steam which previously occurred does not occur in the instant apparatus.

With the foregoing apparatus, it has been found that the temperature of the pressing surface can be accurately controlled within reasonable, acceptable tolerances and steam may be delivered during the pressing operation which has not been excessively dried out as a result of the heating of the pressing plate by the heaters carried thereby.

A preferred arrangement of heating unit 34 is shown in FIG. 8. The heat loss at the sides or edges of the pressing plates tends to be greater than at the center thereof and in order to maintain the uniformity of the temperature of the pressing surface throughout the surface, it has been found desirable to provide for greater heat input at the sides than at the center. The arrangement of the preferred resistance distribution is indicated schematically in FIG. 8. The length of the heater is divided approximately in thirds with the central third being capable of generating less heat as a result of energy input than the outer thirds. The resistance of the heater sections is varied so that, of the total heat supplied by the heater element at a particular input, the two outer thirds make up about 35% each and the central third 30%. The division of the heater into thirds and the heat energy supply into the breakdown of 35%-30%-35% is deemed preferable but not exclusive since the distribution of heat supplied by and along the heater may vary. Of importance in the preferred embodiment is that the heater be non-linear and be capable of providing greater heat input to the pressing plate at the heater ends than at the heater center.

While reference has been made throughout this application to a pressing machine head, the term "head" has been used for ease of description and it will be understood by those in the art that the apparatus of the invention can be used with the pressing surface having substantially any orientation.

It will thus be seen that the objects set forth above, among those made apparent from the preceding description, are efficiently attained and, since certain changes may be made in the above construction without departing from the spirit and scope of the invention, it is intended that all matter contained in the above description or shown in the accompanying drawings shall be interpreted as illustrative and not in a limiting sense.

What is claimed is:

1. A head for a pressing machine comprising a housing including a pressing plate having a pressing surface, said housing defining at least one chamber immediately above said pressing plate, means for controlling delivery of steam to said one chamber, a plurality of steam openings in said pressing plate communicating with said one chamber for delivering steam at said pressing surface, electrical heating means mounted wholly within and completely surrounded by said pressing plate for the heating of same and external means for controlling the operation of said electrical heating means, said pressing plate being of substantial thickness and acting as a heating sink for conduction therethrough of heat generated by said electrical heating means, said electrical heating means including a plurality of electric heating elements mounted within and in heat transfer relationship with said pressing plate, at least one of said electric heating elements being constructed and arranged to transfer greater heat energy to said pressing plate at the ends thereof than at the centers thereof.

2. A head for a pressing machine comprising a housing including a pressing plate having a pressing surface,

5

6

said housing defining at least one chamber immediately above the said pressing plate, means for controlling delivery of steam to said one chamber, a plurality of steam openings in said pressing plate communicating with said one chamber for delivering steam at said pressing surface, electrical heating means mounted wholly within and completely surrounded by said pressing plate for the heating of same and external means for controlling the operation of said electrical heating means, said pressing plate being of substantial thickness and acting as a heat sink for conduction therethrough of heat generated by said electrical heating means, the cross-sectional configuration of said pressing plate including a plurality of arcuate, transversely extending portions extending into said one chamber, said pressing plate including a plurality of internal, transversely extending passages, one passage being provided for each of said arcuate portions, each of said passages being partially surrounded by one of said arcuate portions and said electrical heating means including a plurality of electric heating elements equal in number to the number of said passages with one heating element being located within each of said passages.

3. A head for a pressing machine comprising a housing including a pressing plate having a pressing surface, said housing defining at least one chamber immediately above said pressing plate, means for controlling delivery of externally generated steam to said one chamber, a plurality of steam openings in said pressing plate communicating with said one chamber for delivering steam at said pressing surface, electrical heating means mounted wholly within and completely surrounded by said pressing plate for the heating of same and external means for

controlling the operation of said electrical heating means, said pressing plate being of substantial thickness and acting as a heat sink for conduction therethrough of heat generated by said electrical heating means.

4. A head for a pressing machine as claimed in claim 1 wherein each end third of said electric heating element is constructed and arranged to transfer substantially 35% of its heat energy and the center third is constructed and arranged to transfer substantially 30% of its heat energy.

References Cited

UNITED STATES PATENTS

2,791,045	5/1957	Finlayson	38—17	X
1,150,355	8/1915	French	38—16	
1,272,638	7/1918	DuLaney	38—15	
1,644,929	10/1927	Ledbetter	38—16	
1,865,151	6/1932	Strobfidge	38—15	
1,881,581	10/1932	Hoffman	38—16	
2,307,370	1/1943	Hale	38—15	
3,256,623	6/1966	Radford	38—15	
2,701,926	2/1955	Meyer	38—16	
2,840,938	7/1958	Hale et al.	38—36	
3,286,077	11/1966	Radford et al.	38—16	X
3,319,045	5/1967	Tucker	38—36	X

FOREIGN PATENTS

1,023,894	7/1955	France.	
		(Addition to 63,072)	

MERVIN STEIN, Primary Examiner

GEORGE V. LARKIN, Assistant Examiner