

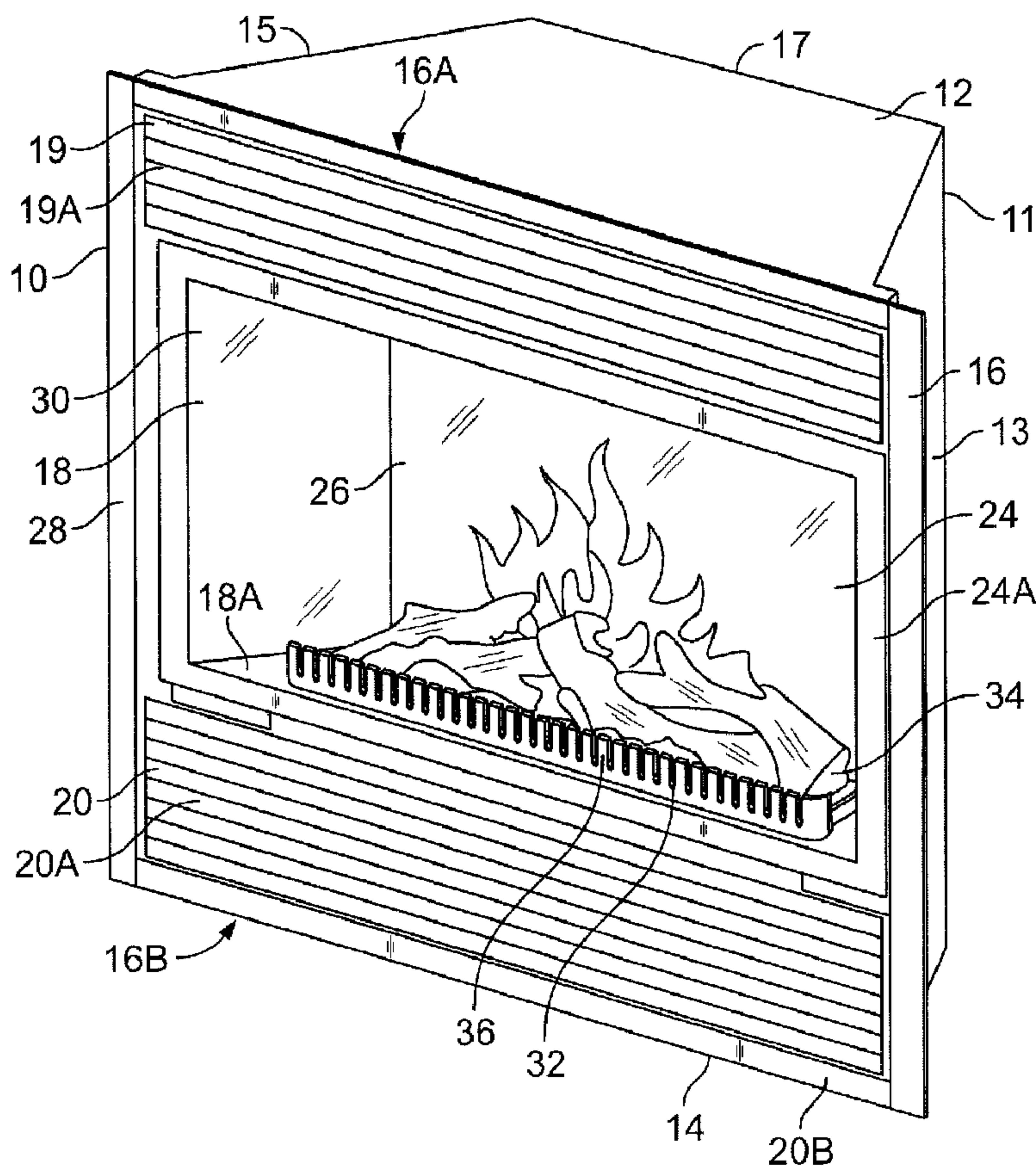

(22) Date de dépôt/Filing Date: 2006/07/19
 (41) Mise à la disp. pub./Open to Public Insp.: 2007/01/19
 (45) Date de délivrance/Issue Date: 2009/10/13
 (30) Priorité/Priority: 2005/07/19 (US60/700,755)

(51) Cl.Int./Int.Cl. *F21S 10/04* (2006.01),
H05B 33/08 (2006.01), *H05B 37/02* (2006.01)
 (72) Inventeurs/Inventors:
LIM, ALVIN, CA;
LAURIE, JANE, CA;
DONG, ZHENXING, CA;
JAMIESON, DONALD R., CA;
NADEN, DAMIR, CA
 (73) Propriétaire/Owner:
GHP GROUP, INC., US
 (74) Agent: BLAKE, CASSELS & GRAYDON LLP

(54) Titre : APPAREIL ET METHODE POUR SIMULER LES EFFETS DE LA COMBUSTION DANS UN FOYER
 (54) Title: APPARATUS AND METHOD FOR SIMULATION OF COMBUSTION EFFECTS IN A FIREPLACE



(57) Abrégé/Abstract:

The present invention produces a combustion simulation of flames, burning logs and embers in a fuel-burning fireplace or like device. One or more light source(s), such as LEDs, are used to transmit light to and through one or more of an artificial log set and

(57) **Abrégé(suite)/Abstract(continued):**

an ember bed. A microprocessor-based controller is used to vary one or more of light intensity and color of the LEDs to simulate a naturally varying glow effect of the ember bed and the log set.

ABSTRACT

The present invention produces a combustion simulation of flames, burning logs and embers in a fuel-burning fireplace or like device. One or more light source(s), such as LEDs, are used to transmit light to and through one or more of an artificial log set and an ember bed. A microprocessor-based controller is used to vary one or more of light intensity and color of the LEDs to simulate a naturally varying glow effect of the ember bed and the log set.

5

APPARATUS AND METHOD FOR SIMULATION OF COMBUSTION EFFECTS IN A FIREPLACE

5

FIELD OF THE INVENTION

The present invention relates generally to electric fireplace technology. In particular, the present invention relates to an apparatus and methods that provide improved simulation of combustion effects in a fireplace through illumination.

BACKGROUND OF THE INVENTION

Fireplaces are desirable features in the home. Traditional wood or other solid fuel burning fireplaces have, however, gradually become replaced by devices that burn non-solid materials, such as gas, or that produce heat electrically. The combustion of gas does provide real flames and heat. However, depending on the geographical region in which the fireplace is used, gas may be an expensive source of energy. Gas combustion also requires a working flue to vent the combustion products.

Electric or electronic fireplaces are a clean and easy source of heat. Electric fireplaces may be installed in locations often for less expense and where gas fireplaces are not desired or will not fit. However, electric fireplaces do not have the same combustion effects that are produced by fuel burning fireplaces.

To overcome this shortcoming, electric fireplace designs have been developed with devices that operate to simulate the flame or fire associated with fuel burning fireplaces. Some electric fireplaces provide a reasonably realistic simulation of a wood-burning fireplace. Electric fireplaces may include simulated burning logs and simulated embers that add to the impression of a wood fire. Various mechanisms have been provided to add moving and/or flickering flames. The success of the simulation depends on the skill of the manufacturer to provide various mechanisms to manipulate combinations of lights, screens, and filters and to provide a random and lifelike flame, burning logs, and ember effect.

A number of these simulated fire devices which provide a visual imitation of natural flames, burning logs and ember bed characteristics of a fire, by way of a simulated effect, have previously been proposed with varying degrees of success. In general, these efforts have produced devices that are complex, multi-component arrangements that are time-consuming and expensive to manufacture. Also, the flame, burning logs and ember bed effect simulated by the devices has been generally limited in scope. With time, consumers find the simulation unconvincing representations of actual combustion effects.

Specifically with respect to electric fireplaces, the flame effect has been generated using very similar techniques for decades. For example, the flame effect in certain embodiments is produced using pieces of light weight fabric such as silk, which is cut into flame-like shapes. A blower creates air flow which in turn moves the fabric to imitate the flame. Another embodiment utilizes a light randomizer, such as aluminum foil pieces, that is rotated in front of a standard

light bulb. The light is reflected over the randomized piece, projected through a mask of flame shape cut-outs and onto a screen. Drawbacks include unrealistic flame appearance and repetition of the flame simulation over a short period of time. An additional disadvantage is that the effect relies on the use of a motor to rotate the light randomizer. The life of the effect, therefore, turns on the life of the motor. Also, the life of a standard light bulb is short and therefore must be frequently replaced.

Electric fireplaces of various designs have been suggested that provide a simulated ember bed effect. For example, U.S Patent 6,162,047 transmits light from a light bulb through a sheet of plastic (or similar) material which has been formed into a grating of transparent, translucent and opaque sections. The transmitted light illuminates the underside of the partially transparent plastic sheet to simulate an ember bed effect. In order to create a flicker-like effect to the ember bed simulation, motor driven rotating pieces of reflective foil generate first or second reflections of the light source. This approach is complicated since it is highly dependent upon accurate placement of many reflecting surfaces. Additionally, overall image quality varies as a viewer moves around the room. An additional drawback of this method is that the embers glow unrealistically since real glowing embers tend to pulse in color and intensity – from low to high intensity and back – depending on the air flow around them.

There is a demand, therefore, for a simple and cost-effective assembly that accurately and realistically simulates the flame or fire that is produced from

the combustion of logs or other combustible fuel source and that can be used in electric or gas burning fireplaces. The present invention satisfies that demand.

SUMMARY OF THE INVENTION

5 The present invention has a principal objective of providing a realistic simulation of that which occurs as a result of the combustion of combustible materials in a fuel-burning fireplace or like device. The combustible material that is simulated in the present invention may be, for example, logs. The result of the combustion that is simulated in the present invention may include the flames, the
10 burning logs, and the embers.

 The assemblies of the present invention may, and in most embodiments will include some type of housing on or in which the present invention is located and operates. The housing of the present invention may take any suitable form as needed or desired and may be in the form of an enclosure or framework,
15 sized and shaped according to a number of considerations. Examples of these considerations include budget, space, aesthetic, mechanical, safety, and other design and operating considerations. Generally, the housing is an enclosure or structure in which or to which mechanisms and components, such as ember bed simulation assembly, logs, and flame simulation unit, are enclosed or attached.
20 The housing is also that which is attached at an installation location. The housing or box may be manufactured from a wide variety of materials, including plastic resin suitable for the application, sheet metal, or any other material known to those skilled in the art.

A fire display box is positioned in the housing. For purposes of this application, the term "fire display box" will broadly signify the area similar to that which is found in a fuel-burning fireplace in which combustion takes place and from which the fire that is produced thereby may be viewed. Traditionally, this area is known as a "firebox," "box," or "fireplace."

One embodiment of the housing includes a top panel, a bottom panel, a back panel and opposing side panels. The two opposing side panels are further optional depending on the application. The housing of this embodiment is sized and shaped to accommodate a fire display box positioned therein. The fire display box is designed to present to a viewer the impression of a working, more traditional non-electronic fireplace. The fire display box is open to the front for viewing purposes and may optionally be provided with a fixed or movable front panel, which may be at least in part transparent, translucent or opaque. For purposes of this application, the front of the fireplace unit is that side of the unit through which the interior of the unit is at least partially viewable. Certain elements of the present invention are located within the fire display box.

The combustion simulation of the present invention may include elements that simulate the flames produced from the combustion of combustible materials. One embodiment of a unit with flame simulation capabilities includes a projection screen visible to the viewer, in the viewing area, or front of the fire display box. At least one light source, or light illumination source, as well as a flame cut-out panel or flame cut-out mask may be contained within the fire display box to simulate the flame effect. In certain embodiments, the flame cut-out panel is

located between the projection screen and the light illumination source. The flame cut-out panel may include a number of individual cut-outs, the shape of each of which is roughly the shape of individual stylized flames, varying in size, shape, and/or form.

5 Another embodiment of flame simulation assembly includes a plurality of light sources and a mask with a plurality of cut-outs. Each light source may be positionable relative to the mask cut-outs to vary the combustion effect. To illustrate, each cut-out on the mask may be situated approximately in front of an individual light source to produce a more intense combustion effect. A light
10 source offset from the mask cut-out produces a less intense combustion effect. Overall, the number of individual light sources and the number of flame cut-outs on the flame cut-out panel may depend on the size of the fire to be replicated. For example, multiple light sources are required if multiple individual flame cut-
15 outs are on the flame cut-out panel. The position of the light illumination source(s) is not obvious to the viewer since it is positioned behind the flame cut-out panel.

20 An additional embodiment includes a screen or privacy glass panel, made of material that has a property of changing the opacity according to the electric current applied to it. The privacy glass panel has a high degree of transparency when electrical current is applied. A controller applies electrical current to the privacy glass when the fireplace is turned off. This allows the user to see through this glass and have the visual perception of the logs and ember bed when the fireplace is off. The privacy glass is cloudy or hazy when no electrical

current is applied. A controller prevents the flow of electrical current to the privacy glass when the fireplace is turned on. The privacy glass can be positioned anywhere inside the fireplace – such as inside the ember-bed or imitation logs – because it is nearly invisible to the user when the fireplace unit is
5 off.

More specifically, the privacy glass may be made from clear or tinted glass or a glass-like polymeric-based material, such as polycarbonates, through the use of which image of flickering flames is produced that is well defined and realistic. The material used for the privacy glass can be free-forming so that the
10 glass can be manipulated into any shape desired. For example, forming the privacy glass to a three-dimensional shape can create the look of a flame that would appear to be coming from different planes within the ember-bed and/or logs, greatly improving the realism of the fire effect in the electric fireplaces.

An embodiment of the flame simulation assembly may include simulated
15 logs with portions that appear to be undergoing or that had recently undergone combustion. The logs, for example, can be made from ceramic, Styrofoam or any other material that can be made to resemble a wood surface. The simulated logs may include combustion portions that are sized, shaped, and colored, and/or that facilitate illumination to simulate a log or logs in the process of combustion.
20 For example, in this embodiment, the simulated logs may include an opening or openings with centered “cut-outs” defined by log edges that – due to size, shape and color – have the appearance of burning just as the burning edge of a real log in a real wood fireplace that is in the process of being combusted. Light may be

transmitted from one or more light source(s) to and through the cut-outs in the log.

The combustion simulation may comprise or include a simulation of an ember bed. The ember bed simulation of the present invention is constructed from a suitable material such that the size, shape, texture, and/or color of an ember bed of a conventional wood burning fireplace is simulated. The ember bed simulation is positioned preferably on the bottom panel of the fire display box. To assist in the simulation of the ember bed, a light source may be positioned within or adjacent to the fire display box to provide illumination. To further assist in the simulation of an ember bed, the light source may be positioned such that at least a portion of the light passes through an element or elements that refract the light. The element or elements that refract light for purposes of this application shall be termed "refractories". The refractories may be positioned within the simulated ember bed and juxtaposed relative to the simulated fire elements and burn patterns to give a look closely resembling real embers burning in a wood fireplace.

One embodiment of the refractories includes a surface having at least one face on the surface, to allow refraction of light in more than one direction. This allows the simulation of a glowing ember bed effect to be viewed from more than one angle from the front of the fireplace. The refractories may include a surface having a plurality of faces positioned around the surface so that light is refracted in a multiple of directions thereby assisting in the ember bed simulation. The refractories may be one single multifaceted bead or a plurality of beads to

realistically replicate real bed embers. Refractories that are suitable for this purpose include multifaceted beads made from plastic, glass, or a naturally occurring material; broken pieces of tempered glass; and broken pieces of plastic such as acrylic or polycarbonate may be used as refractories. The refractories may be clear or colored including those that are, for example painted with stained glass paint.

One embodiment of the ember bed simulation includes multiple light sources positioned generally adjacent to and underneath the refractories on the ember bed. The position of any one of the light sources preferably facilitates the approximation of the overall size and shape of a real ember bed but is not apparent to one observing the simulation.

Another preferred embodiment of the present invention uses light emitting diodes, termed LEDs for some or all illumination purposes. A light emitting diode is any semiconductor device that emits visible light when an electric current is passed through it. LEDs can be of varying type such as air gap LEDs, GaAs LEDs and polymer LEDs. LEDs are high intensity, energy efficient illumination sources. LEDs, either individually or custom packaged, are commercially available. LEDs produce light in many colors, including, but not limited to, amber, yellow, orange, green, blue and white – further, an individual LED may be designed to change colors, varying from amber to yellow to orange, in response to an electrical signal. LEDs give off virtually no heat and have a relatively unlimited lifetime, essentially eliminating the need for replacement. The LEDs may comprise a plurality, or cluster, of LEDs. Alternatively, the LEDs may

comprise one individual LED. Again, the intensity of the light source may be varied such as by varying the location and/or number of LEDs. Further, the LEDs can include a textured surface to provide "diffused light". "Sandblasting" provides such a textured surface.

5 Illumination in other embodiments of the present invention may be provided by one or more long-life halogen light bulbs, incandescent light bulbs, flame based sources, carbon arc radiation sources, fluorescent sources, luminescent bulbs or induction light bulbs. Some embodiments of the present invention contemplate a combination of LEDs and non-LED sources of light as
10 will be detailed below. Fiber optic cables, or any other material that facilitates the transmission of light, such as acrylic or nylon, may be used to assist in transmitting the visible light from source to a point of illumination and ultimately, a viewer.

 The light sources may be controlled by a controller, sequencing device, or
15 sequencer, that is able to produce light effects, for example, timing, flashing, repetition, color changes, brightness changes and the like. The sequencing device of the preferred embodiment includes a printed circuit board with a microprocessor that is electrically connected to the light sources. The microprocessor is programmable to provide electrical signals to one, a group of,
20 or all of the LEDs. The programmed control can be manipulated so as to closely approximate the pulsing intensities of light seen in actual flames, the edges of burning logs, and ember beds. The program of the sequencer can be changed to vary the flame, log burning edge, and ember bed effect.

These and other advantages, as well as the invention itself, will become apparent in the details of construction and operation as more fully described and claimed below. Moreover, it should be appreciated that several aspects of the invention can be used in other applications where realistic (flame and ember bed) simulations would be desirable.

BRIEF DESCRIPTION OF THE DRAWINGS

FIG. 1 is a front view of an electric fireplace according to one embodiment of the present invention in use;

FIG. 2 is a partial front view of an electric fireplace that simulates flames according to one embodiment of the present invention;

FIG. 3 is a front view of one embodiment of a flame deflector for use in an electric fireplace for simulating flames;

FIG. 4A is a front view of a flame generator assembly that is behind the flame deflector of FIG. 3;

FIG. 4B is a front view of a LED array behind the flame deflector of FIG. 3, and

FIG. 5 is a side perspective view of a microprocessor control board, LED array and reflective surface and a cutaway side view of a electric fireplace according to an embodiment of the present invention.

DETAILED DESCRIPTION OF A PRESENTLY PREFERRED EMBODIMENT

The present invention will now be described in detail with reference to certain embodiments thereof as illustrated in the accompanying drawings. In the following description, numerous specific details are set forth in order to provide a thorough understanding of the present invention. It will be apparent, however, to one skilled in the art, that the present invention may be practiced without some or all of these specific details. In other instances, well-known process steps and/or structures have not been described in detail to prevent unnecessarily obscuring the present invention.

The present invention is used as an electric fireplace 10. The assembly of one type of electric fireplace 10 that is the subject of the present invention is illustrated in FIG. 1. This embodiment of fireplace 10 includes a housing 11 having a top panel 12, a bottom panel 14, two opposing side panels 13 and 15, a front side 16, and a back panel 17 that collectively generally define an interior 18. Other embodiments of an electric fireplace 10 may include various shaped panels, brackets, rods, bulkheads, rails, posts, and so on (not specifically shown). The housing 11 of the embodiment shown in FIG. 1 is of any suitable form or material sufficient to provide for installation, support, insulation, and/or aesthetic considerations of the fireplace 10. For example, one suitable material from which the housing 11 may be manufactured is sheet metal. The sheet metal is cut, bent and joined (not specifically shown) to form the structure of the housing 11. In the preferred embodiment shown in FIG. 1, the back panel 17 and two opposing side panels 13 and 15 are cut from a single piece of sheet metal and

bent into shape. The combined back panel 17 and side panels 13 and 15 of the housing are commonly referred to as the fireplace wrapper. The top panel 12 and bottom panel 14 each may be attached to the upper and lower edges of the back panel 17 and side panels 13 and 15 (i.e., the fireplace wrapper) to complete the basic structure of the housing 11. The edges of the individual side panels 13, 15 are typically bent to provide a small overlap at the juncture of adjoining panels. The metal panels are then joined together by suitable fasteners such as sheet metal screws or by other methods such as by welding.

It will be understood that the present invention may be effectively used where desired in conjunction with heat-producing and non-heat-producing electric fireplaces as well as other similar types of mechanisms, enclosures or products. The present illustrated embodiment is directed to an electric fireplace having features that actually function to enable the use of heat-producing mechanisms, such as an electric blower, or simulate the capability of a fireplace with such a heat-producing mechanism. Of course, the simulated flame assembly of the present invention may be used in a product which does not include all or any of these mechanisms or features, some of which are discussed below.

The upper portion 16A of the front side 16 of the electric fireplace illustrated in FIG. 1 includes an upper louver panel 19 having a series of spaced horizontal slats or louvers 19A. Slats 19A are spaced apart to allow room air to pass in through upper louver panel 19 and subsequently be expelled back into the room. Slats 19A of upper louver panel 19 are angled upwardly from front to

back in such a manner as to prevent someone who is standing in front of the electric fireplace from seeing through upper louver panel 19. Upper louver panel 19 may be made removable to permit access to the interior of housing 11 in the event that maintenance or repair is necessary.

5 The lower portion 16B of front side 16 of electric fireplace 10 illustrated in FIG. 1 comprises a lower louver panel 20 similar in design and configuration as that of upper louver panel 19. In other words, lower louver panel 20 is comprised of a series of horizontal slats or louvers 20A that are spaced and angled in a similar fashion as slats 19A of upper louver panel 19. Lower louver panel 20
10 may be sized and shaped to conceal any switches (not shown) and other devices that control the operation of electric fireplace 10. In the preferred embodiment, the bottom edge 20B of lower louver panel 20 is connected to bottom panel 14 of housing 11 with one or more hinges or similar devices (not shown) that permit lower louver panel 20 to be folded outwardly and downwardly to gain access to
15 any electric fireplace circuitry, for example, or other internal components (not shown). The hinges may contain springs that bias lower louver panel 20 in a vertical or closed position.

 The upper and lower louver panels, 19 and 20, may be also designed and configured to simulate a concealed heat exchanger plenum arrangement of the
20 type often incorporated in combustible fuel-burning fireplaces (not shown). For example, natural gas fireplaces often have a series of interconnected plenums surrounding the fire display box that form a convection air passage around the fire display box. Room air is typically drawn into and expelled out from the

plenum arrangement by passing through louver panels above and below the fire display box. Louver panels 19, 20 of the preferred embodiment are designed and configured to suggest the presence of a heat exchange plenum arrangement, thereby increasing the realism of the electric fireplace.

5 Front side 16 of electric fireplace 10 may include a viewing portion 24 through which portions of interior 18 may be viewed. Viewing portion 24 may be in the form of a panel 24A (as shown) or, in the alternate, be translucent or an opaque door, which, for purposes of viewing the interior 18, may be opened. Depending on the desired aesthetic appearance, the fireplace viewing portion 24
10 may be either clear, tinted, or a privacy glass panel that has a property of changing the opacity according to the electric current applied to it. Tinting of viewing portion 24 may increase the realism of the fireplace by inhibiting the viewer's ability to discern the components used to create the illusion of a real wood-burning fire. In the preferred embodiment shown, viewing portion 24 is
15 clear glass. Any transparent material can be utilized for viewing portion 24. For example, clear or tinted acrylic could be used in lieu of glass or a glass-like polymeric-based material, such as polycarbonates. Viewing portion 24 in the embodiment illustrated in FIG. 1 is positioned between upper and lower louver panels, 19 and 20, and permits viewing of the simulated fire display box 26.
20 However, privacy glass can be positioned anywhere inside the fireplace, for example inside the ember-bed or imitation logs. Viewing portion 24 may be supported by a frame 28 and includes hardware (not shown) of the same type as or a version of which is ordered to simulate a glass door assembly of the type

typically used to enclose the fire display box of a combustible fuel-burning fireplace. Viewing portion 24 with or without frame 28 is moveable or is removable to permit cleaning, maintenance or repair of components within a fire display box 26.

5 Fire display box 26 is provided within housing 11 or formed variously from components of housing 11. As will be discussed in greater detail below, fire display box 26 supports various components of electric fireplace 10. A fire display box surface 30 is typically used to line the fire display box of combustible fuel-burning fireplaces and may be painted to appear like firebrick. Alternatively,
10 ceramic fiber refractory panels or the like (not shown) – that have been shaped and colored to look like firebrick – can be attached to the interior surface of housing 11 to form a realistic appearing fire display box 26. The manufacturing process for vacuum forming and coloring ceramic fiber refractory panels is well known in the art. Other materials can also be used to manufacture the artificial
15 refractory panels.

Within the lower portion 18A of fire display box 26, an artificial log and ember set 32 is positionable. Log and ember set 32 in the embodiment illustrated in FIG. 1 comprises one or more artificial logs 34 supported by an artificial ember bed 36. Artificial logs 34 are shaped and colored to simulate the
20 appearance of actual logs of any type. Ember bed 36 is shaped and colored to simulate the appearance of burnt portions from a log and/or burning coals or embers. Artificial logs 34, as well as ember bed 36, may be molded from ceramic fiber by a vacuum forming process that is well known in the art.

Other materials may also be used to manufacture artificial logs 34 and ember bed 36. For example, these components may be molded from concrete, which provides for greater detail than can be achieved by using ceramic fiber. However, concrete is much heavier and is prone to breakage if accidentally
5 dropped. The artificial logs 34 and embers 36 can also be made from other materials such as plastic.

FIG. 2 shows another view of the fireplace interior 18. The fireplace interior 18 is defined, at least in part, by the fire display box 26 and includes an ember bed 36 underneath a set of artificial logs 34. The rear of the firebox 26 is
10 a display screen 27 for displaying simulated flames.

In one embodiment, the ember bed 36 is made of a plastic material, which has the property of being at least translucent in some portions so as to permit light to pass through or illuminate the ember bed from within and appear to glow, for example. The log set 34 preferably has the same property as the ember bed
15 of permitting illumination from within so as to provide a glowing or the like. Any suitable material may be used for the ember bed 36 and log set 34, which permits some transmission of light therethrough to provide the appearance of a glow, heating or flame effect, for example.

A front panel 14A may be provided with a set of controls 40 and/or
20 sensors 42 for operation of the various features of the fireplace 10. The controls 40 may include, for example, a speed control for varying the speed of the simulated flames, the speed of the varying glow effect in various parts of the fireplace 10, volume of sound effects, overhead lights (not shown), and

fragrance. The sensors 42 may sense the light intensity in the environment (i.e., the room in which the fireplace is present), and the sound level in the environment. The front panel may include one or more receiving device (not shown) for receiving control signals from a remote control 44. The invention
5 contemplates any suitable control signal, for example, infrared (IR) and radio frequency (RF).

Output from the sensors 42 may be used by the microprocessor based controller to control, at least in part, the overall intensity of sounds generated by the fireplace (e.g., simulated or recordings of crackling and burning of fuel) or the
10 overall light intensity generated by the fireplace 10 (e.g., glow and flame effects and other lighting).

FIG. 3 shows an embodiment of a flame deflector or flame mask 46. The flame deflector 46 is disposed in the rear of the firebox (see FIG. 1). The flame deflector 46 includes a panel of material, which is preferably opaque, with a
15 plurality of cutouts 48. The cutouts 48 are preferably flame shaped to fashion simulated flames when light from a light source (not shown) is directed therethrough.

FIG. 4A shows a flame mask 46 with an attached flame simulator 50. The flame simulator 50 depicted includes a rotating foil wrapped shaft which
20 somewhat randomly reflects light. Flame light source 51 is disposed to direct light onto the flame simulator 50 and through the flame mask 46 onto the rear of a tinted or non-tinted projection screen 27 (see FIG. 2). Other suitable flame simulators are contemplated including internally illuminated rotating tubes with

cutout portions (not shown) and so on. The flame simulator 50 may be rotated by an electrical motor 52. Another embodiment of the flame simulator may include one or more sets of LEDs (see FIG. 4B) which simulate flames by varying in light intensity and color.

5 FIG. 4B shows the flame deflector 46 of FIG. 3 and a LED array 47 positioned adjacent the flame deflector to provide a realistic flame effect. The LED array 47 is provided in electrical communication with the controller (see FIG. 5) and caused to vary in one or more of color and intensity to simulate flame effects.

10 FIG. 5 shows a microprocessor-based controller 54, which includes a one or more microprocessor board, which may be attached near the front of the fireplace 10 and may be disposed behind panel 14A (see FIG. 2) and which provides electrical signals to various light sources in the fireplace 10 by means of electrical connections 58, for example a simple wire, or using more sophisticated
15 “bus” technologies. The light source shown in FIG. 5 includes a LED array 56. The light source may also include the LED array 47 of FIG. 4B. The LED array 56 is arranged to direct light onto an angled reflector 60 which is arranged underneath the fire display box 26 to direct light through a number of firebox ember bed cutouts 62. The light shining through the cutouts 62 can be seen
20 through the ember bed 36 (see FIG. 1). An optional speaker or pair of speakers 64 may be provided in electrical connection with the controller 54 to provide fire simulating sounds. Similarly, an optional aroma producing mechanism 66 may be provided in electrical connection with the controller 54.

While light source 56 may be a single source, the light source shown in the FIG. 5 embodiment is preferably a plurality of LEDs. The electrical signals produced by controller 54 control various aspects of light source 56, such as which of the individual LEDs of light source 56 are 'on' or 'off', the duration each individual LED is 'on' or 'off', and the quantity of LEDs that are made available to be 'on' or 'off'. The LEDs may also be varied by intensity and/or color, for example. Upon receiving an 'on' electrical signal from controller 54, light source 56 emits light from its LEDs.

The light emitted from LEDs 56 and 47 may vary in intensity, color, and may be controlled so as to produce a pattern of illumination simulating the changes produced by a natural ember bed or flame respectively. The speed of the changes of the LEDs 56 may be controlled to correlate to the speed of the flame simulating device 50 (see FIG. 4A).

The log set 32 (see FIG. 1) may be provided with internal light sources (not shown) and controlled in the same or a similar or a totally dissimilar manner as that of the ember bed 36. The controller 54 may also synchronize the flame speed, LED pattern and the sounds made by the speakers 64 to provide a more realistic simulated fireplace experience.

Described is an electric fireplace assembly with a combustion simulation arrangement which provides for realistic flame-like and/or ember bed-like effect. While the above-described assembly is intended to be used, in one embodiment with an electric fireplace, it is to be realized that flame and ember bed

arrangements according to the invention could be incorporated in other types of heaters or perhaps other decorative arrangements.

Whilst endeavoring in the foregoing specification to draw attention to those features of the invention believed to be of particular importance it should be understood that the Applicants claim protection in respect of any patentable feature or combination of features hereinbefore referred to and/or shown in the drawings whether or not particular emphasis has been placed thereon. While the apparatus and method herein disclosed forms a preferred embodiment of this invention, this invention is not limited to that specific apparatus and method, and changes can be made therein without departing from the scope of this invention, which is defined in the appended claims.

Therefore, the foregoing is considered as illustrative only of the principles of the invention. Further, since numerous modifications and changes will readily occur to those skilled in the art, it is not desired to limit the invention to the exact construction and operation shown and described, and accordingly, all suitable modifications and equivalents may be resorted to, falling within the scope of the invention.

We Claim:**1. A flame simulation assembly comprising:**

- a housing including a firebox;
- an ember bed positioned within said firebox; said ember bed having at least one light transmissive portion;
- a light source comprising a plurality of LEDs positioned beneath said ember bed for emitting light through said at least one light transmissive portion of said ember bed; and
- a controller for controlling said light source, wherein said controller functions to vary at least one of light intensity and light color of the light generated by said light source.

2. The flame simulation assembly of claim 1 wherein said at least one light transmissive portion of said ember bed comprises at least one cutout.

3. The flame simulation assembly of claim 1 or claim 2 further comprising an angled reflector positioned beneath said ember bed and arranged to direct light from said light source through said at least one light transmissive portion of said ember bed.

4. The flame simulation assembly of any one of claims 1 to 3, wherein said controller functions to control said light source to simulate natural variations in the light intensity of said light source in a non-random pattern.

5. The flame simulation assembly of any one of claims 1 to 4 further comprising a simulated log set.

6. The flame simulation assembly of claim 5 further comprising:

- a flame mask positioned behind said simulated log set, said flame mask having at least one light transmissive portion; and
- a flame simulator for transmitting light through said at least one light transmissive portion of said flame mask and illuminating at least a portion of said simulated log set.

7. The flame simulation assembly of claim 6 wherein said flame simulator comprises a light source positioned to direct light onto a rotating foil wrapped shaft.

8. The flame simulation assembly of claim 5 further comprising:
- a flame mask positioned behind said simulated log set, said flame mask having at least one light transmissive portion; and
 - a second light source positioned behind said flame mask and comprising a plurality of LEDs for transmitting light through said at least one light transmissive portion of said flame mask;
- wherein said controller functions to vary at least one of light intensity and light color of the light generated by said second light source.
9. The flame simulation assembly of claim 8 wherein said at least one light transmissive portion of said flame mask comprises at least one cutout.
10. The flame simulation assembly of any one of claims 5 to 9 wherein said simulated log set comprises internal light sources.
11. A flame simulation assembly comprising:
- a housing including a firebox;
 - a simulated log set within said firebox.
 - a flame mask positioned behind said simulated log set, said flame mask having at least one light transmissive portion;
 - a light source positioned behind said flame mask and comprising a plurality of LEDs for emitting light through said at least one light transmissive portion of said flame mask; and
 - a controller for controlling said light source, wherein said controller functions to vary at least one of light intensity and light color of the light generated by said light source.
12. The flame simulation assembly of claim 11 wherein said at least one light transmissive portion of said flame mask comprises at least one cutout.
13. The flame simulation assembly of claim 11 or claim 12, wherein said controller functions to control said light source to simulate natural variations in the light intensity of said light source in a non-random pattern.
14. The flame simulation assembly of any one of claims 11 to 13 wherein said simulated log set comprises internal light sources.

15. The flame simulation assembly of any one of claims 1 to 14 further comprising at least one speaker connected to said controller, wherein said at least one speaker and controller function to generate sounds to simulate combustion.

16. The flame simulation assembly of any one of claims 1 to 15 further comprising an aroma producing mechanism for producing aroma to simulate combustion of wood.

17. The flame simulation assembly of any one of claims 1 to 16 further comprising a remote control for generating control signals, and a receiver for receiving said control signals, wherein said control signals are used for instructing said controller to change operation of said light source.

18. The flame simulation assembly of any one of claims 1 to 17 further comprising a sound sensor in communication with said controller, said sound sensor for sensing sound levels.

19. The flame simulation assembly of any one of claims 1 to 18 further comprising a light sensor in communication with said controller, said light sensor for sensing light levels.

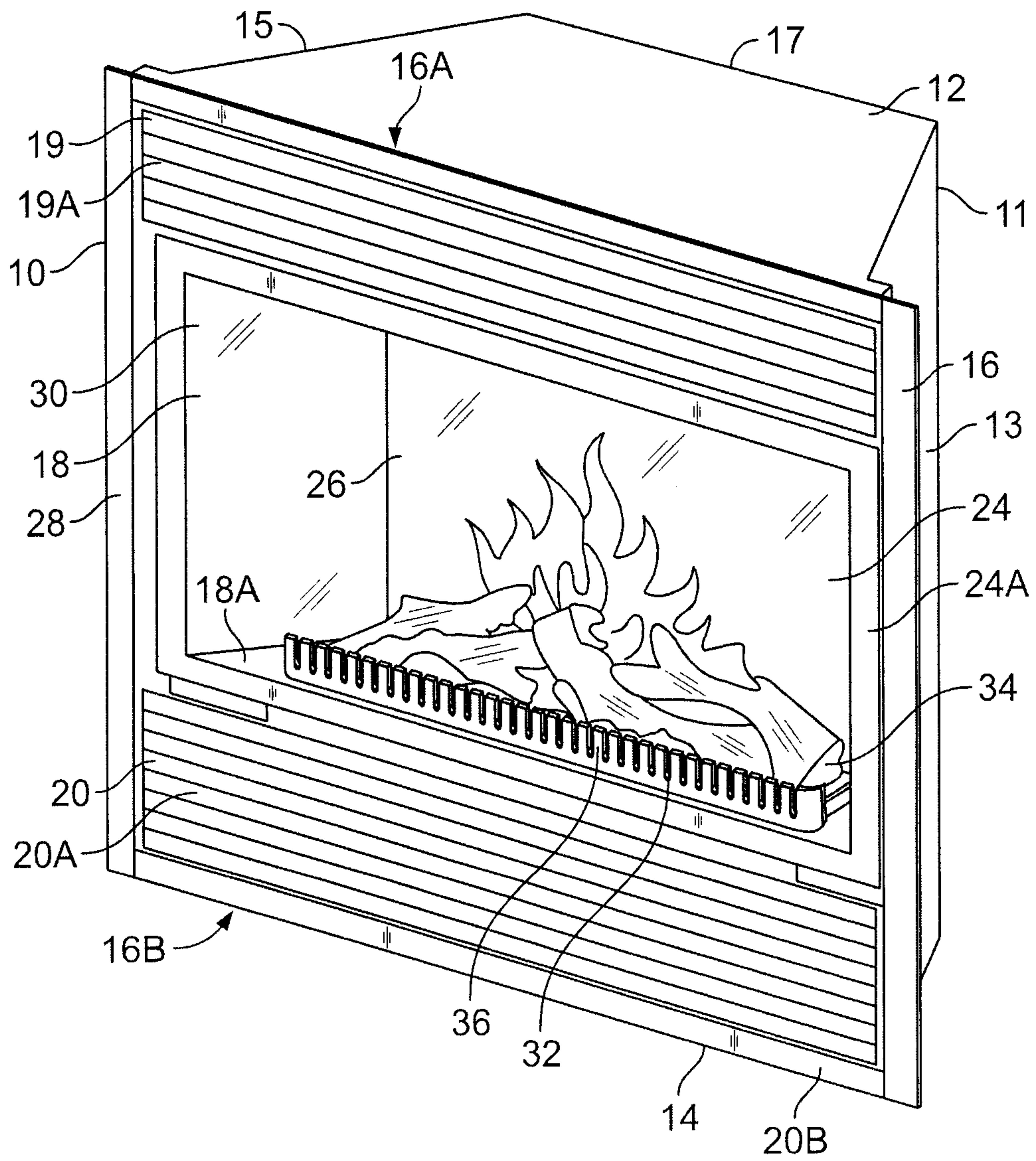

FIG. 1

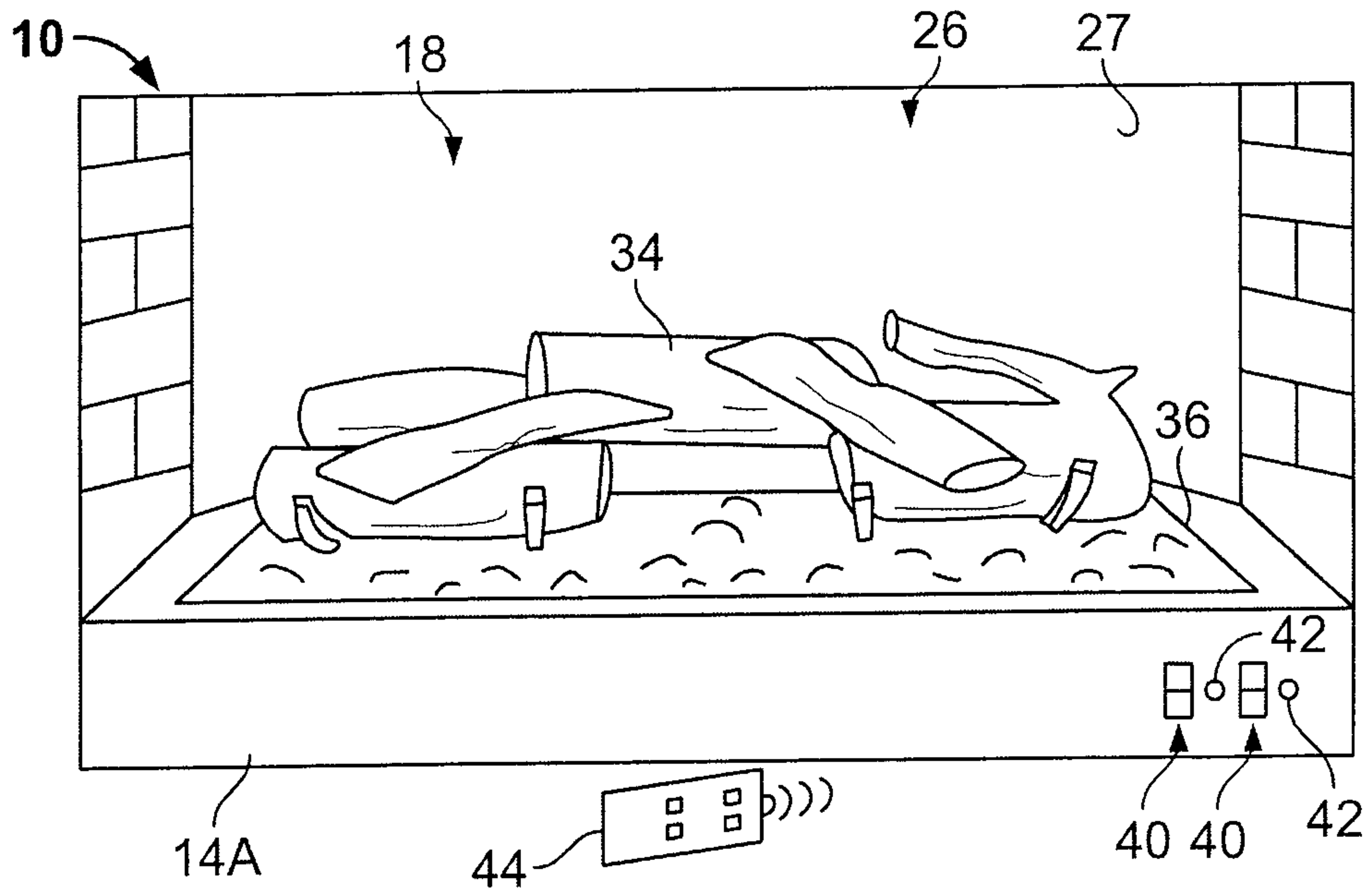

FIG. 2

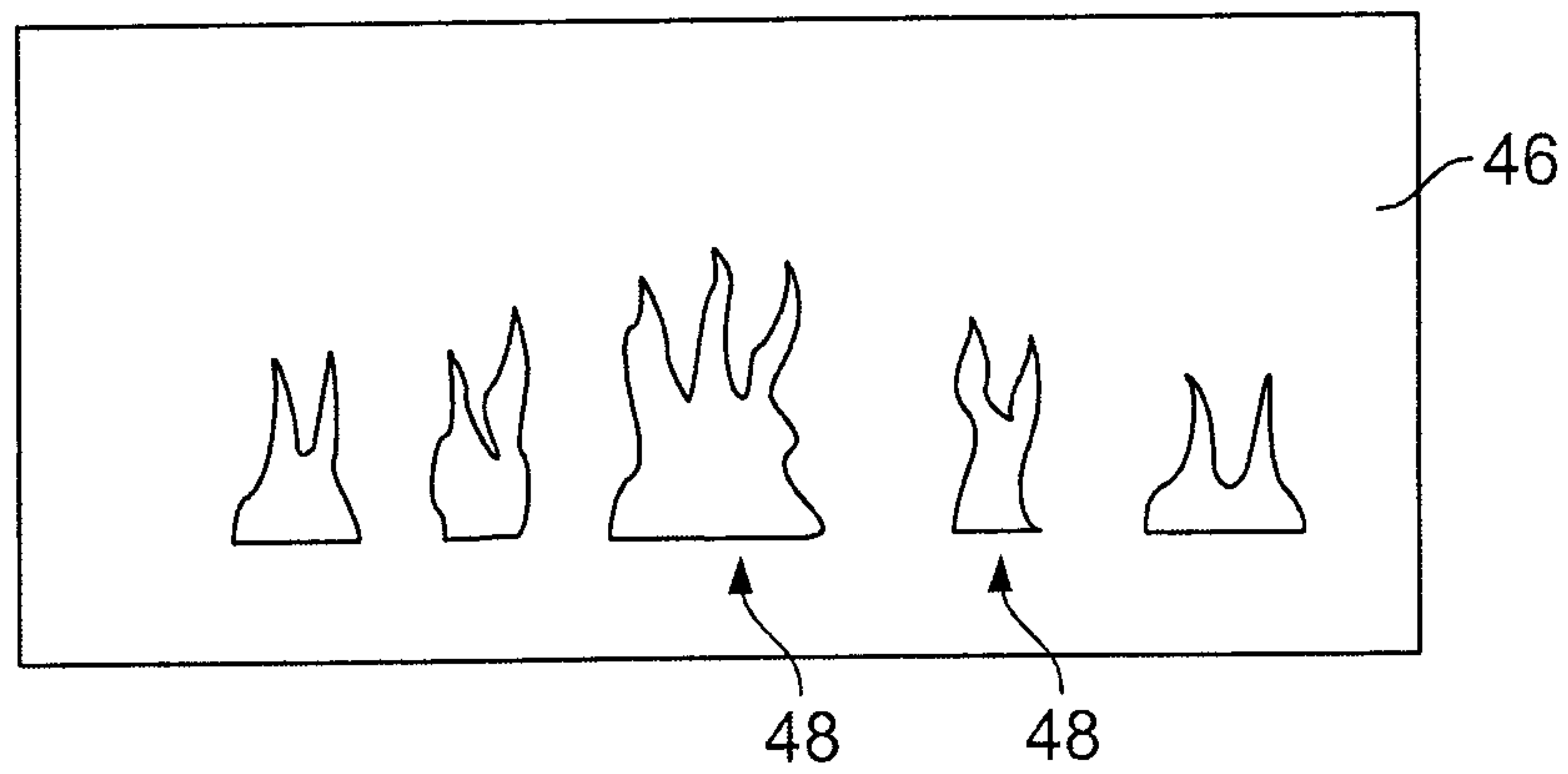

FIG. 3

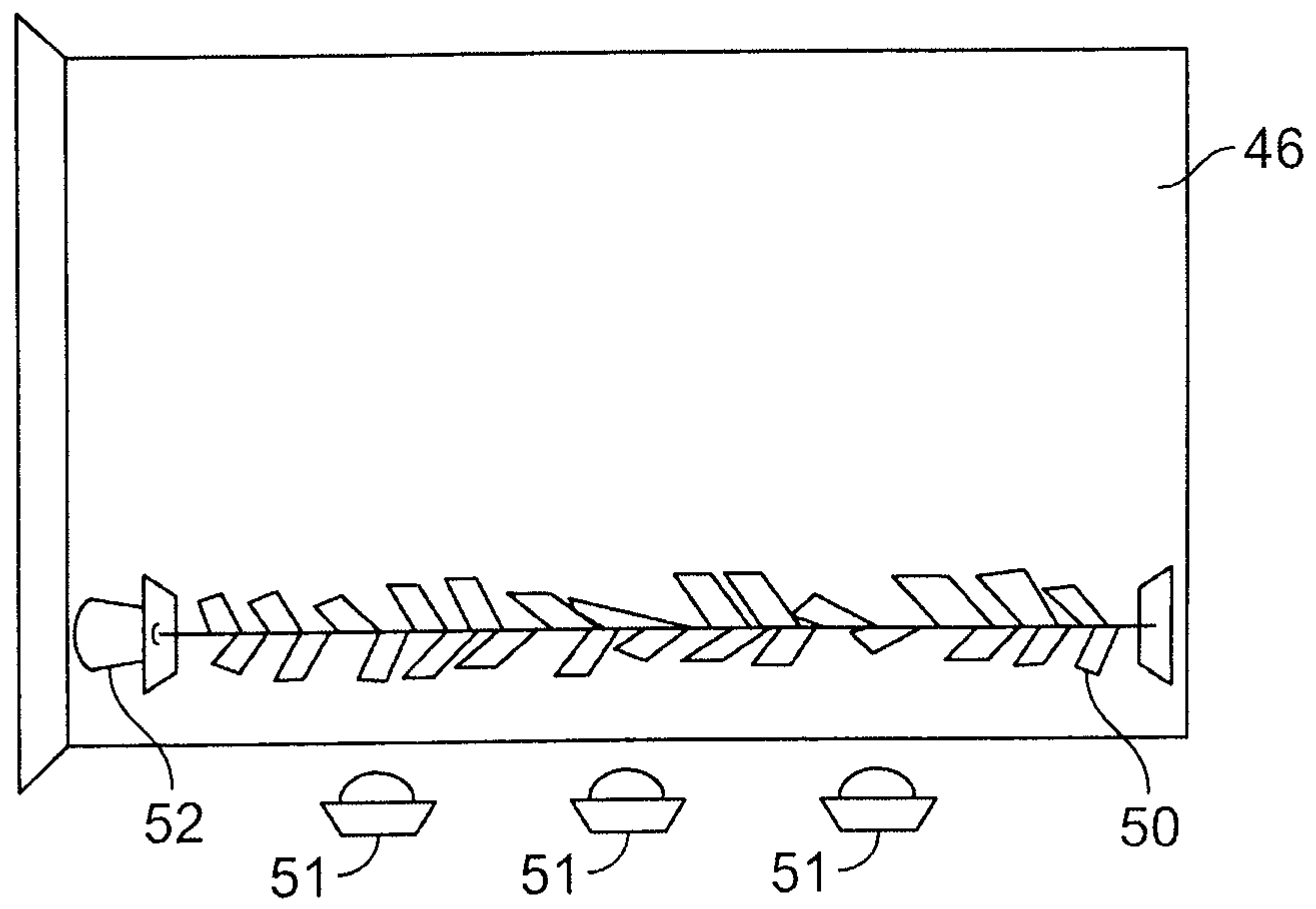

FIG. 4A

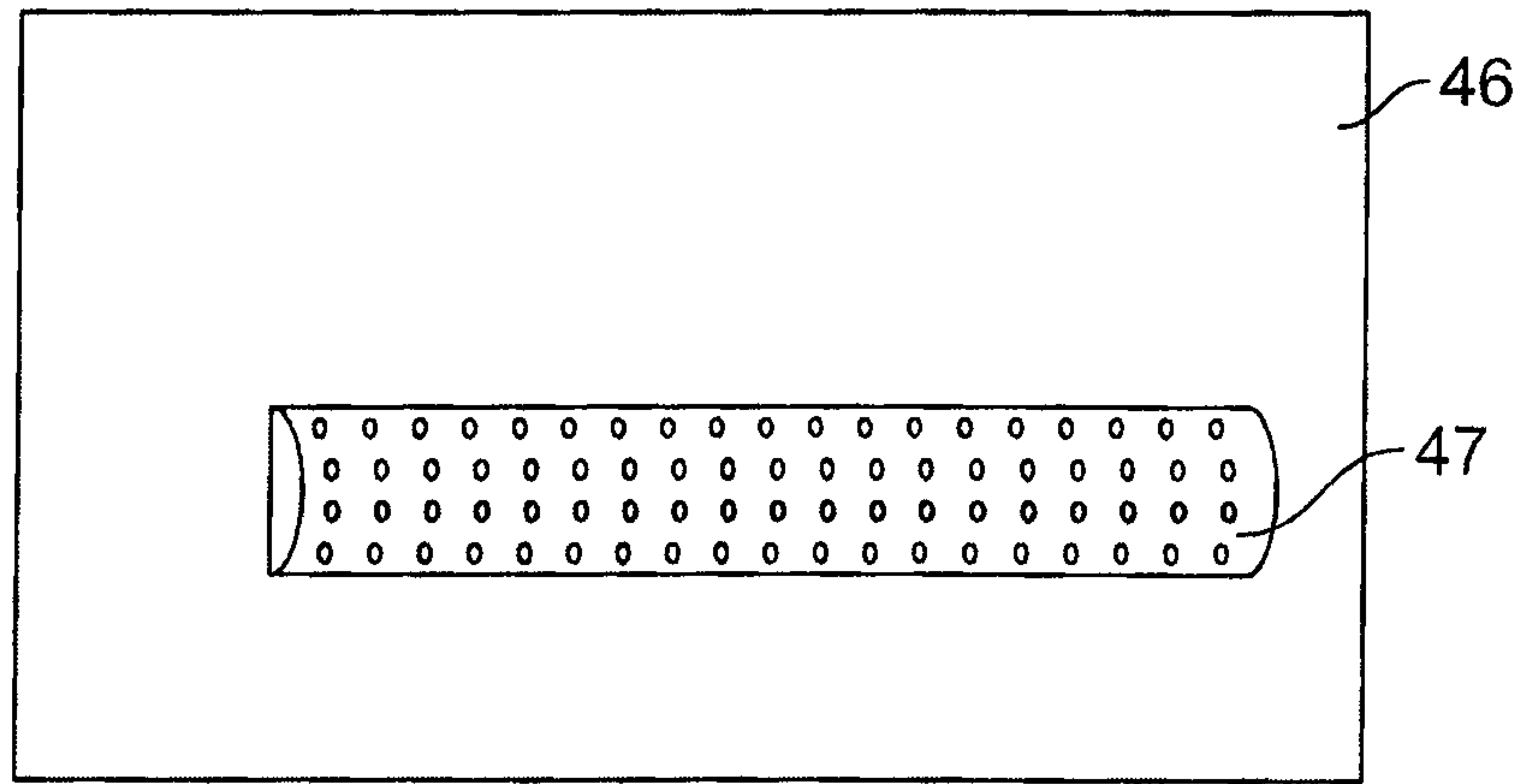

FIG. 4B

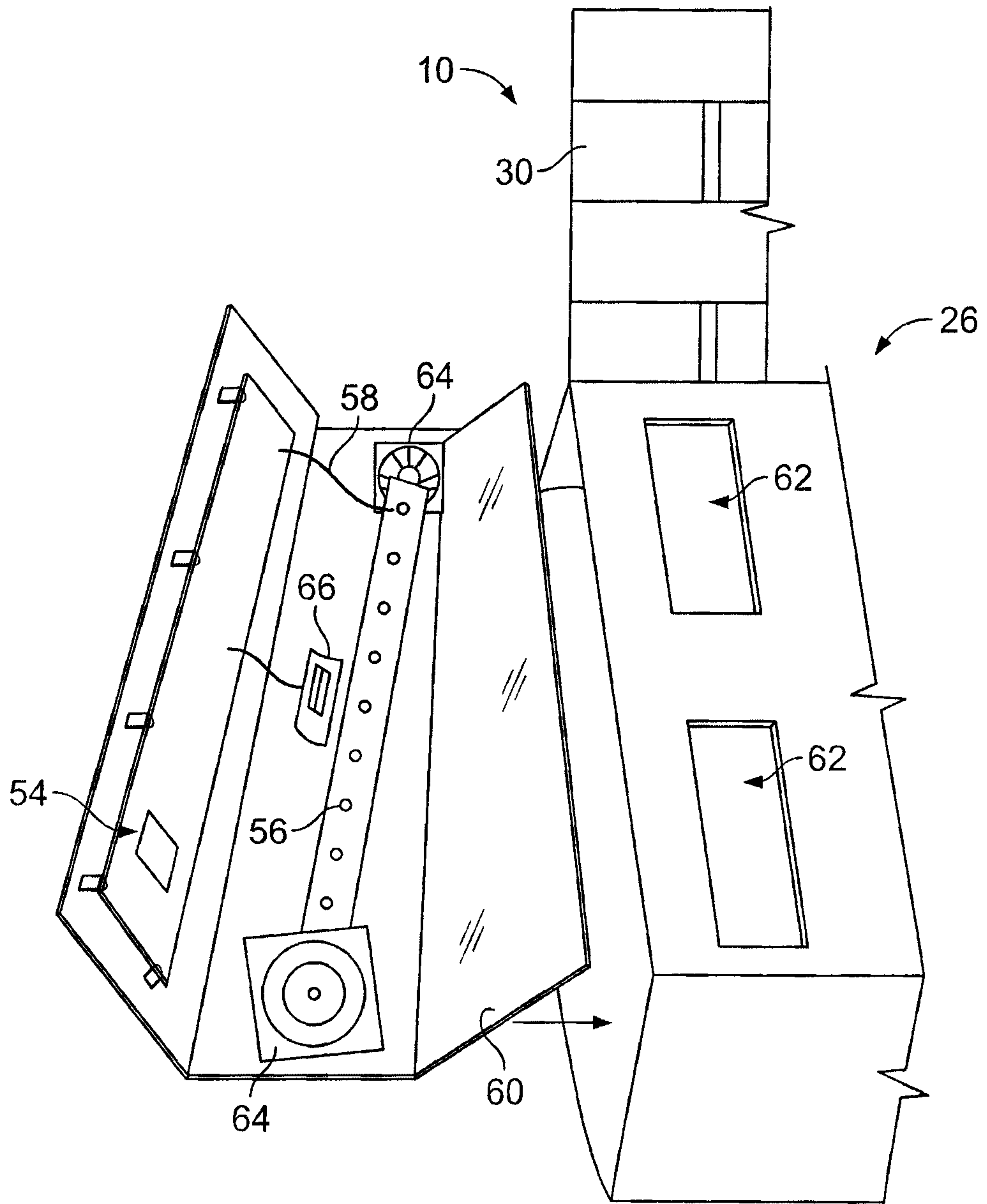

FIG. 5

