

(19) World Intellectual Property Organization
International Bureau



(43) International Publication Date
8 November 2007 (08.11.2007)

PCT

(10) International Publication Number
WO 2007/125429 A2

- (51) International Patent Classification: Not classified (74) Agents: CORIZZI, Valérie et al.; Cabinet Ores, 36 rue de Saint Petersburg, F-75008 Paris (FR).
- (21) International Application Number: PCT/IB2007/002486 (81) Designated States (unless otherwise indicated, for every kind of national protection available): AE, AG, AL, AM, AT, AU, AZ, BA, BB, BG, BH, BR, BW, BY, BZ, CA, CH, CN, CO, CR, CU, CZ, DE, DK, DM, DZ, EC, EE, EG, ES, FI, GB, GD, GE, GH, GM, GT, HN, HR, HU, ID, IL, IN, IS, JP, KE, KG, KM, KN, KP, KR, KZ, LA, LC, LK, LR, LS, LT, LU, LY, MA, MD, ME, MG, MK, MN, MW, MX, MY, MZ, NA, NG, NI, NO, NZ, OM, PG, PH, PL, PT, RO, RS, RU, SC, SD, SE, SG, SK, SL, SM, SV, SY, TJ, TM, TN, TR, TT, TZ, UA, UG, US, UZ, VC, VN, ZA, ZM, ZW.
- (22) International Filing Date: 26 April 2007 (26.04.2007)
- (25) Filing Language: English
- (26) Publication Language: English
- (30) Priority Data: 60/745,905 28 April 2006 (28.04.2006) US
- (71) Applicant (for all designated States except US): CENTRE NATIONAL DE LA RECHERCHE SCIENTIFIQUE [FR/FR]; 3 rue Michel Ange, F-75016 Paris (FR).
- (72) Inventors; and
- (75) Inventors/Applicants (for US only): MORVAN, François [FR/FR]; 17 rue de l'opale, F-34170 Castelnaud Le Lez (FR). MEYER, Albert [FR/FR]; 11 rue des Rascasses, F-34470 Perols (FR). VASSEUR, Jean-Jacques [FR/FR]; 5 allée du plein sud, F-34980 Combaillaux (FR). VIDAL, Sébastien [FR/FR]; 26A rue Arago, F-69100 Villeurbanne (FR). CLOAREC, Jean-Pierre [FR/FR]; 5 rue Coustou, F-69001 Lyon (FR). CHEVOLOT, Yann [FR/FR]; 58 impasse des Lilas, F-69210 Fleurieux Sur L'arbresle (FR). SOUTEYRAND, Eliane [FR/FR]; 30 rue de Chouzy, F-41190 Chambon Sur Cisse (FR).
- (84) Designated States (unless otherwise indicated, for every kind of regional protection available): ARIPO (BW, GH, GM, KE, LS, MW, MZ, NA, SD, SL, SZ, TZ, UG, ZM, ZW), Eurasian (AM, AZ, BY, KG, KZ, MD, RU, TJ, TM), European (AT, BE, BG, CH, CY, CZ, DE, DK, EE, ES, FI, FR, GB, GR, HU, IE, IS, IT, LT, LU, LV, MC, MT, NL, PL, PT, RO, SE, SI, SK, TR), OAPI (BF, BJ, CF, CG, CI, CM, GA, GN, GQ, GW, ML, MR, NE, SN, TD, TG).
- Published:
— without international search report and to be republished upon receipt of that report
- For two-letter codes and other abbreviations, refer to the "Guidance Notes on Codes and Abbreviations" appearing at the beginning of each regular issue of the PCT Gazette.



WO 2007/125429 A2

(54) Title: METHOD FOR THE SYNTHESIS OF OLIGONUCLEOTIDE DERIVATIVES

(57) Abstract: Method for the synthesis of nucleotide derivatives wherein molecules of interest are grafted on the oligonucleotide with the help of a "click chemistry" reaction between an azide function on the molecule of interest and an alkyne function on the oligonucleotide, or between an alkyne function on the molecule of interest and an azide function on the oligonucleotide. Intermediate molecules, notably alkyne functionalized oligonucleotides, grafted oligonucleotides, azide functionalized oligonucleotides, oligonucleotide micro arrays containing them and the use of those grafted oligonucleotides for biological investigation and for cell targeting.

METHOD FOR THE SYNTHESIS OF OLIGONUCLEOTIDE DERIVATIVES

The invention is directed to a method for the synthesis of nucleotide derivatives wherein molecules of interest are grafted on the oligonucleotide with the help of a "click chemistry" reaction between an azide function on the molecule of interest and an alkyne function on the oligonucleotide, or between an alkyne function on the molecule of interest and an azide function on the oligonucleotide.

Other objects of the invention are intermediate molecules, notably alkyne functionalized oligonucleotides, azide functionalized oligonucleotides, grafted oligonucleotides, oligonucleotide micro arrays containing them and the use of those grafted oligonucleotides for biological investigation and for cell targeting among others.

Oligonucleotides are molecules consisting of a short chain of nucleotides, the number of which can vary from one to around one hundred. They are important molecular tools for genomic research and biotechnology (Caruthers, M. H. *Science* **1985**, *230*, 281-285). Most applications require labeling with dyes or other biomolecules such as peptides (Zatsepin, T. S.; Turner, J. J.; Oretskaya, T. S.; Gait, M. J. *Curr. Pharm. Des.* **2005**, *11*, 3639-3654), or carbohydrates (Zatsepin, T. S.; Oretskaya, T. S. *Chem. Biodiversity* **2004**, *1*, 1401-1417).

Oligonucleotides are typically synthesized on solid support using phosphoramidite chemistry (Beaucage, S. L.; Caruthers, M. H. *Tetrahedron Lett.* **1981**, *22*, 1859-1862). Their conjugation with carbohydrates has been performed on one hand on solid support using either solid-supported carbohydrates (Adinolfi, M.; De Napoli, L.; Di Fabio, G.; Iadonisi, A.; Montesarchio, D.; Piccialli, G. *Tetrahedron* **2002**, *58*, 6697-6704; D'Onofrio, J.; de Champdore, M.; De Napoli, L.; Montesarchio, D.; Di Fabio, G. *Bioconjugate Chem.* **2005**, *16*, 1299-1309) or carbohydrate phosphoramidites (Adinolfi, M.; De Napoli, L.; Di Fabio, G.; Iadonisi, A.; Montesarchio, D.; Piccialli, G. *Tetrahedron* **2002**, *58*, 6697-6704; D'Onofrio, J.; de Champdore, M.; De Napoli, L.; Montesarchio, D.; Di Fabio, G. *Bioconjugate Chem.* **2005**, *16*, 1299-1309; Sheppard, T. L.; Wong, C. H.; Joyce, G. F. *Angew. Chem., Int. Ed.* **2000**, *39*, 3660-3663; Tona, R.; Bertolini, R.; Hunziker, J. *Org. Lett.* **2000**, *2*, 1693-1696; de Kort, M.; de Visser, P. C.; Kurzeck, J.; Meeuwenoord, N. J.; van der Marel, G. A.; Rüger, W.; van Boom, J. H. *Eur. J. Org. Chem.* **2001**, 2075-2082; Dubber, M.; Frechet, J. M. J. *Bioconjugate Chem.* **2003**, *14*, 239-246), and on the other hand in solution using reactive carbohydrate derivatives (Akasaka, T.; Matsuura, K.; Emi, N.; Kobayashi, K. *Biochem. Biophys. Res. Commun.* **1999**, *260*, 323-328; Forget, D.; Renaudet, O.; Defrancq, E.; Dumy, P. *Tetrahedron Lett.* **2001**, *42*, 7829-7832; Dey, S.; Sheppard, T. L. *Org. Lett.* **2001**, *3*, 3983-3986). Nevertheless, these strategies require multi-step synthesis and are time consuming.

There remained the need for a method permitting the grafting of varied molecules of interest on an oligonucleotide backbone, with the possibility to graft several different molecules of interest on the oligonucleotide backbone, wherein said method permits the grafting of molecules of interest either on the 3'-, or on the 5'-extremity of the oligonucleotide, or inside the sequence.

The inventors have found that the use of a "click chemistry" reaction between an azide function on the molecule of interest and an alkyne function grafted on a phosphonate diester functionalization of the oligonucleotide permitted to reach this goal.

A first object of the invention is a method for the preparation of an oligonucleotide grafted by a molecule of interest R wherein said method comprises the step of reacting an azido function attached to R with an alkyne substituted phosphodiester derivative of the oligonucleotide, as depicted on figure 1A and 1B.

On figure 1A, an oligonucleotide is grafted by a function responding to formula (Ia)

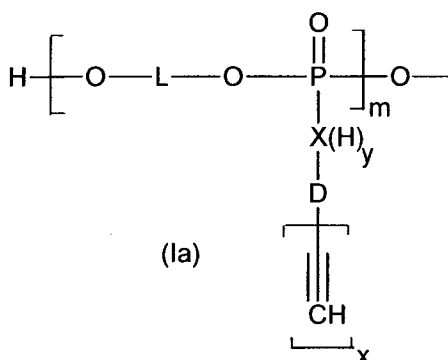

wherein X is selected from N, O, S, an alkane di-yl comprising 1 to 12 carbon atoms, like $-\text{CH}_2-$, $-\text{CH}_2-\text{CH}_2-$... ; preferentially X is selected from N, O ;

m is an integer, $m \geq 1$

L is a linker which may be selected from the following list: alkane di-yl functions with 1 to 12 carbon atoms, linear branched or cyclic possibly interrupted by one or several oxygen (-O-), nitrogen (-NH-, -N=) or sulphur (-S-) bridges or phosphodiester [-O-(O⁻)P(=O)-O-] bridges;

x is an integer, $30 \geq x \geq 1$

D is a linker between X and the alkyne group(s). According to the value of x, D's valency is 2 or more. Preferably, D is selected from alkane poly-yl groups comprising 1 to 36 carbon atoms, possibly interrupted by one or several oxygen (-O-), nitrogen (-NH-, -N=) or sulphur (-S-) bridges or phosphodiester [-O-(O⁻)P(=O)-O-] bridges. (figure 12)

According to the choice of X and D, y is 0, 1 or 2;

In formula (I) and (III) B is selected from H, a solid support (array, polymer, beads) or a tag.

On figure 1B, an oligonucleotide is grafted by a function responding to formula (Ib)

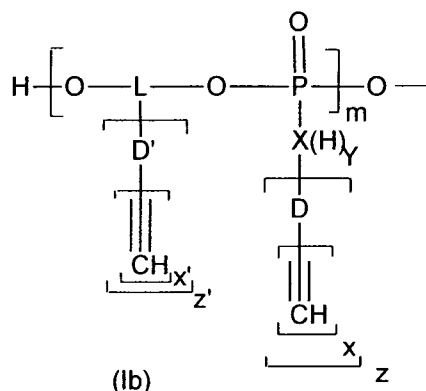

wherein X is selected from N, O, S, an alkane di-yl comprising 1 to 12 carbon atoms, like $-\text{CH}_2-$, $-\text{CH}_2-\text{CH}_2-\dots$; preferentially X is selected from N, O;

m is an integer, $m \geq 1$

L is a linker which may be selected from the following list: alkane poly-yl functions with 1 to 12 carbon atoms, linear branched or cyclic possibly interrupted by one or several oxygen (-O-), nitrogen (-NH-, -N=) or sulphur (-S-) bridges or phosphodiester $[-\text{O}-(\text{O}^-)\text{P}(=\text{O})-\text{O}-]$ bridges;

x is an integer, $30 \geq x \geq 1$

x' is an integer, $30 \geq x' \geq 1$

D is a linker between X and the alkyne group(s). According to the value of x, D's valency is 2 or more. Preferably, D is selected from alkane poly-yl groups comprising 1 to 36 carbon atoms, possibly interrupted by one or several oxygen (-O-), nitrogen (-NH-, -N=) or sulphur (-S-) bridges or phosphodiester $[-\text{O}-(\text{O}^-)\text{P}(=\text{O})-\text{O}-]$ bridges;

D' is a linker between L and the alkyne group(s). According to the value of x', D''s valency is 2 or more. Preferably, D' is selected from alkane poly-yl groups comprising 1 to 36 carbon atoms, possibly interrupted by one or several oxygen (-O-), nitrogen (-NH-, -N=) or sulphur (-S-) bridges or phosphodiester $[-\text{O}-(\text{O}^-)\text{P}(=\text{O})-\text{O}-]$ bridges;

z and z' are integers, z and z' ≥ 0 , at least one of z and z' is ≥ 1 ;

According to the choice of X and D, y is 0, 1 or 2;

In formula (I), (III), (XIII) and (XIV) B is selected from H, a solid support (array, polymer, beads) or a tag.

On formula (I) of figure 1A and (XIV) of figure 1B, the oligonucleotide is substituted by the function (Ia), respectively (Ib), either on its 3'-extremity, on its 5'-

extremity or inside of the sequence, one P atom of the function (Ia) or (Ib) being part of the oligonucleotide chain. According to a variant illustrated on figure 12, the oligonucleotide of formula (I) or (XIV) can be an oligonucleotide derivative wherein one or several phosphate function(s) of the oligonucleotide chain has been replaced by a phosphoramidate group of the type:

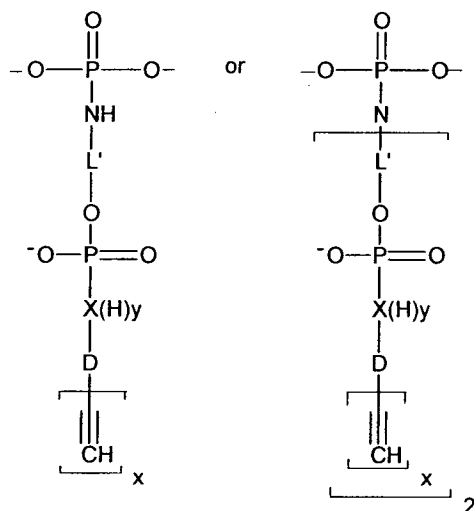

in which L' is an alkane di-yl chain comprising 1 to 12 carbon atoms.

In that case, the P atom of the phosphodiester group in the (Ia) or (Ib) formula is not part of the oligonucleotide chain, but is linked to the oligonucleotide chain through a P-NH-L'-O-P link. The grafted nucleotide of formula (I) or (XIV) can be in solution (case when B=H or a tag), or it can comprise a grafting to a solid support by one of its extremities (case when B=solid support).

The molecule of interest R is grafted by an azido function.

When the azido-functionalized molecule of interest (II) is contacted with the oligonucleotide derivative (I) or (XIV) in appropriate quantity, a 1,3-dipolar cycloaddition occurs leading to the triazole (III), respectively (XIII).

This 1,3-dipolar cycloaddition is very chemoselective, only occurring between alkynyl and azido functional groups with high yields. The resulting 1,2,3-triazoles are stable at high temperature and in aqueous conditions.

The molecule of interest can be any molecule for which there is an interest at obtaining a condensation product with an oligonucleotide. For the sake of illustration, mention may be made of: carbohydrates, peptides, lipids, oligonucleotides, biotin, ferrocenyl compounds, fluorescent tags ...

Favourite molecules of interest are carbohydrates, including their various derivatives. The importance of oligonucleotide-carbohydrate conjugates has been highlighted by T.S. Zatsepin and T.S. Oretskaya in *Chemistry and Biodiversity*, vol. 1

(2004), 1401-1417. This review also highlights the difficulties associated to their preparation and lists the few methods known for this purpose.

Carbohydrates include mono and polysaccharides and their derivatives. As monosaccharides and their derivatives, mention may be made of glucose, fructose, mannose, ribose, glyceraldehyde, ribose, erythrose, threose, xylose, arabinose, lyxose, ribulose, xylulose, allose, altrose, gulose, idose, lactose, galactose, talose, sorbose, tagatose, psicose, dihydroxy acetone, glucosamine, N'-acetylglucosamine, glucuronic acid, sialic acid ...

Polysaccharides can be built by any combination of monosaccharides and monosaccharide derivatives, either identical or different, in a linear or branched assembly.

Particularly preferred are molecules (II) consisting of a mono or a polysaccharide grafted on one of its extremities by a $-\text{CH}_2-(\text{CH}_2-\text{O}-\text{CH}_2)_r-\text{CH}_2-\text{N}_3$ group, with r an integer, $r \geq 1$, $r=1, 2, 3, 4, 5, 6, \dots$

Another type of favourite molecules of interest R consists of amino acids and peptides. Tags, like fluorescent tags notably are also favorite molecules of interest that one can graft on the oligonucleotide chain, by using the method of the invention. Such variants are illustrated on figure 18. On this figure is illustrated the preparation of an oligonucleotide comprising $m+2$ nucleotide units, the 5'-extremity being grafted by a fluorescein and the 3'-extremity bearing a phosphate di-ester chain of four units, each unit being substituted by a linker arm bearing two guanidine residues.

Preparation of molecules (II) can be performed according to the scheme illustrated on figure 2 in the case of galactose.

Penta-O-acetyl galactopyranosyl is reacted with $\text{HOCH}_2(\text{CH}_2\text{OCH}_2)_r\text{CH}_2\text{Cl}$, wherein r is an integer, $r \geq 1$ (here $r=2$), in the presence of BF_3 in diethylether. Then a treatment of the resulting chloride with NaN_3 and $n\text{Bu}_4\text{Ni}$ gives the expected azido derivative. The choice of reactive illustrated in figure 2 is not limiting, $\text{HOCH}_2(\text{CH}_2\text{OCH}_2)_r\text{CH}_2\text{OTs}$ or $\text{HOCH}_2(\text{CH}_2\text{OCH}_2)_r\text{CH}_2\text{I}$ could be used instead of $\text{HOCH}_2(\text{CH}_2\text{OCH}_2)_r\text{CH}_2\text{Cl}$.

This method is given for the purpose of illustration. Any other known method for preparing azido derivatives is acceptable. A list of such reactions is given in *Advanced Organic Chemistry*, J. March, Wiley, 1985, p.1155.

With regards to the conditions for reacting the azide derivative (II) with the oligonucleotide (I) or (XIV) as illustrated on figure 1A and 1B, the favourite conditions are the following.

The molecule (II) is in solution in an appropriate solvent (water and/or organic) and the molecule (I) or (XIV) is either in solution or grafted onto a solid support (resin or glass or silicon for example). Preferentially the reaction is made with application of microwaves.

Microwave activation significantly improves the reaction kinetic. Heating at a temperature superior to room temperature also has a positive effect on the reaction kinetic. Preferentially the reactive medium is heated to a temperature comprised between 30 and 100°C. However, at room temperature the reaction occurs also.

5 The reaction is performed with the presence of a Copper (Cu^+) catalyst that could be for example generated by CuSO_4 and sodium ascorbate.

Molecules of formula (XIV) and (I), which are a particular variant of molecules (XIV), are key intermediates in the method which has been described above. As such they are another object of the invention.

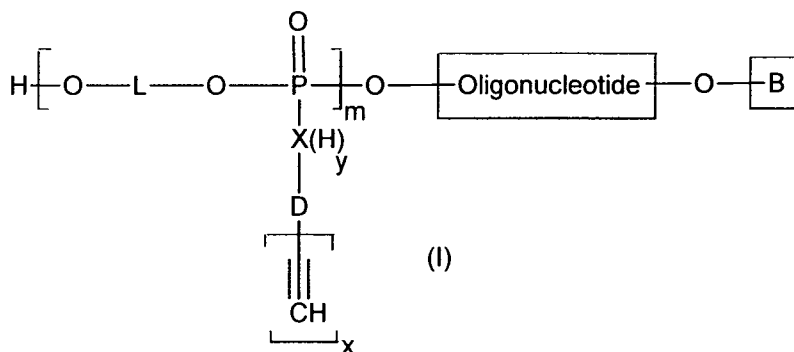
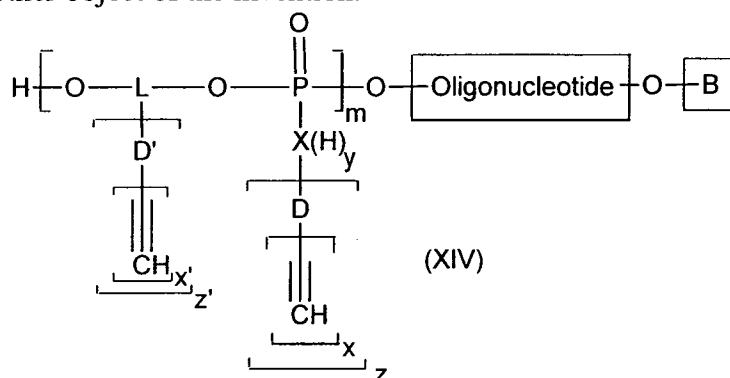

The variables in formula (I) and (XIV) are the same as defined above:

15 X is selected from N, O, S, an alkane di-yl comprising 1 to 12 carbon atoms, like $-\text{CH}_2-$, $-\text{CH}_2-\text{CH}_2-\dots$; preferentially X is selected from N, O;

m is an integer, $m \geq 1$

20 L is a linker which may be selected from the following list: alkane poly-yl functions with 1 to 12 carbon atoms, linear branched or cyclic possibly interrupted by one or several oxygen ($-\text{O}-$), nitrogen ($-\text{NH}-$, $-\text{N}=\text{}$) or sulphur ($-\text{S}-$) bridges or phosphodiester $[-\text{O}-(\text{O}^-)\text{P}(=\text{O})-\text{O}-]$ bridges;

x is an integer, $30 \geq x \geq 1$; in (I) L is selected from alkane di-yl radicals with 1 to 12 carbon atoms, linear branched or cyclic possibly interrupted by one or several

oxygen (-O-), nitrogen (-NH-, -N=) or sulphur (-S-) bridges or phosphodiester [-O-(O⁻)P(=O)-O-] bridges;

x' is an integer, $30 \geq x' \geq 1$

5 D is a linker between X and the alkyne group(s). According to the value of x , D's valency is 2 or more. Preferably, D is selected from alkane poly-yl groups comprising 1 to 36 carbon atoms, possibly interrupted by one or several oxygen (-O-), nitrogen (-NH-, -N=) or sulphur (-S-) bridges or phosphodiester [-O-(O⁻)P(=O)-O-] bridges;

10 D' is a linker between L and the alkyne group(s). According to the value of x' , D's valency is 2 or more. Preferably, D' is selected from alkane poly-yl groups comprising 1 to 36 carbon atoms, possibly interrupted by one or several oxygen (-O-), nitrogen (-NH-, -N=) or sulphur (-S-) bridges or phosphodiester [-O-(O⁻)P(=O)-O-] bridges;

z and z' are integers, z and $z' \geq 0$, at least one of z and z' is ≥ 1 ;

15 The oligonucleotide can be a nucleotide chain comprising 1 to 100 nucleotide units, the chain of formula (Ia) or (Ib) being grafted on its 3'-extremity, on its 5'-extremity or inside of the sequence, one P atom of the function (Ia) or (Ib) being part of the oligonucleotide chain. According to a variant illustrated on figure 12, the oligonucleotide of formula (I) or (XIV) can be an oligonucleotide derivative wherein one
20 or several phosphate function(s) of the oligonucleotide chain has been replaced by a phosphoramidate group of the type:

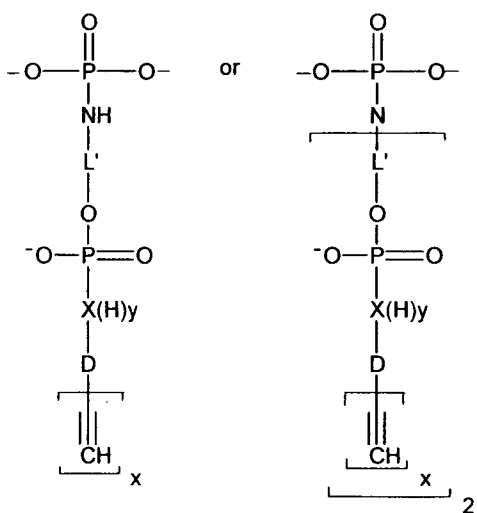

25 in which L' is an alkane di-yl chain comprising 1 to 12 carbon atoms. In that case, the P atom of the phosphodiester group in the (Ia) or (Ib) function is not part of the oligonucleotide chain, but is linked to the oligonucleotide chain through a P-NH-L'-O-P link.

According to the choice of X and D, y is 0, 1 or 2;

In formula (I), (III), (XIV) and (XIII) B is selected from H, a solid support (array, polymer, beads) or a tag.

5 Particularly, in molecules of formula (I) and (XIV), favourite variants are the following:

m is an integer selected from 1, 2, 3, 4, 5, 6.

L is a linker selected from:

- an alkane poly-yl (di-yl for (I)) with 1 to 12 carbon atoms, linear, branched or cyclic;

10 - a group $\left[\text{CH}_2\text{-CH}_2\text{-O} \right]_t \text{CH}_2\text{-CH}_2\text{-}$ with t an integer selected from 1, 2, 3, 4, 5, 6;

- an alkane poly-yl (di-yl for (I)) with 1 to 12 carbon atoms including an oxygen comprising heterocycle, like a ribose cycle;

15 D is an alkane poly-yl group comprising 1 to 12 carbon atoms possibly interrupted by one or several oxygen bridges.

Examples of linkers are given here-under for the purpose of illustration.

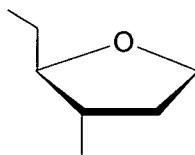
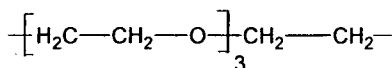

20 According to the linker's length, the distance between the molecules of interest will be modulated.

D can be divalent like an alkane di-yl comprising 1 to 12 carbon atoms. For example D can be $-\text{CH}_2-$.

25 D can have a higher valency and create a link between the nitrogen and several alkyne functions so that a dendrimer can be built.

As an illustrative example of this case,

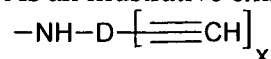

can be:

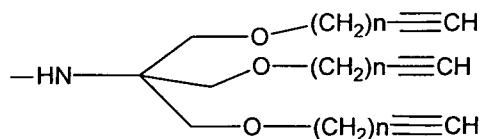

with n an integer $n \geq 1$, like for example:

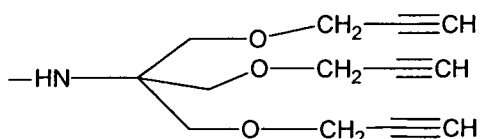

5

Another possibility for obtaining a multifunctional compound is to have the amine substituted twice by an alkyne bearing linker.

For example

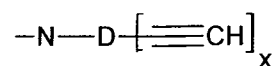

10

can be:

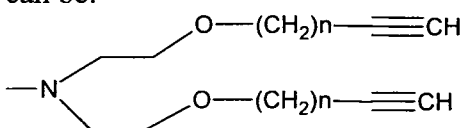

with n an integer $n \geq 1$, like for example:

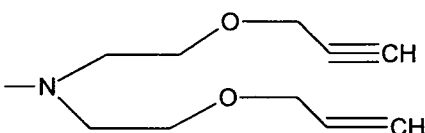

15

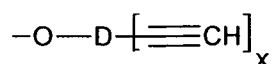

can be:

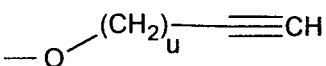

20

with u an integer

All combinations of the illustrated variants are possible.

Methods for the introduction of one, two or three alkyne functions on the phosphoester or phosphoramidate function are illustrated on figures 13, 14, 15 and 16. Examples of molecules of formula (III) and (XIII) obtained from a phosphodiester comprising three alkyne functions, or a phosphoramidate comprising four alkyne functions, are illustrated on figure 17.

25

B can be H or a tag or a resin or a glass or silicon plaque, a bead, a polymer.

The reaction depicted on figure 1A and 1B can be performed with B=H or B= tag or B= a solid support.

If it is performed with B= a solid support, and if desired, the resulting product (III) or (XIII) can then be detached from the solid support with an appropriate
5 treatment.

When R is a carbohydrate or a carbohydrate derivative, the reaction depicted on figure 1A or 1B is done with an appropriate protection on R's hydroxyl functions. This protection can be removed after the 1,3-cycloaddition has been performed.

Variants of this type are illustrated on figure 3, in the case when the
10 molecule of interest is tetra acetyl galactosyl.

A molecular array comprising an oligonucleotide-grafted solid support (glass, silicon, polymer or resin) to which molecules (Ia) or (Ib) are hybridized, directly to the oligonucleotides or through a linker arm, is another object of the invention. It corresponds to molecule (I) and (XIV) when B is a solid support.

The Huisgen's 1,3-dipolar cyclo addition between alkyne and azide is very attractive since it is nearly quantitative, can be performed in water with an organic co-solvent and multiple cycloadditions can be performed on multivalent scaffolds (Wang, Q.; Chan, T. R.; Hilgraf, R.; Fokin, V. V.; Sharpless, K. B.; Finn, M. G. *J. Am. Chem. Soc.* **2003**, *125*, 3192-3193). Furthermore, this reaction is orthogonal to most typical organic
15 transformations and therefore highly chemoselective.

"Click chemistry" has been successfully applied for fluorescent labeling of oligonucleotides in solution (Seo, T. S.; Li, Z.; Ruparel, H.; Ju, J. *J. Org. Chem.* **2003**, *68*, 609-612) and recently for the attachment of an oligonucleotide on a monolayer (Devaraj, N. K.; Miller, G. P.; Ebina, W.; Kakaradov, B.; Collman, J. P.; Kool, E. T.;
20 Chidsey, C. E. D. *J. Am. Chem. Soc.* **2005**, *127*, 8600-8601) and for DNA metallization (Burley, G. A.; Gierlich, J.; Mofid, M. R.; Nir, H.; Tal, S.; Eichen, Y.; Carell, T. *J. Am. Chem. Soc.* **2006**, *128*, 1398-1399).

However prior art "click chemistry" applied to oligonucleotides used azido functionalized oligonucleotides in which only one azido function could be
30 introduced at the 5' extremity of the oligonucleotide, or alkyne phosphoramidite oligonucleotides or nucleotides substituted on their basic ring by an alkyne radical.

Nowhere in the prior art is mentioned or suggested to use alkyne phosphoester derivatives of the oligonucleotides to make the 1,3-cyclo addition with an azide substituted molecule of interest. Neither is it taught or suggested to use azide
35 phosphoester derivatives of the oligonucleotides to make the 1,3-cyclo addition with an alkyne substituted molecule of interest

This method is extremely efficient for the synthesis of substituted oligonucleotides with a substitution at the 3'-extremity, the 5'-extremity or inside of the sequence itself.

In the case of a 3'-substituted oligonucleotide of formula (XIV) or (I), the reaction with the azido substituted molecule of interest (II) can be followed by another step of oligonucleotide synthesis, so that other nucleotide units are added to the chain, and alkyne functionalization can be performed on those units, so that another, and possibly a different azido substituted molecule of interest can be grafted on the oligonucleotide chain.

According to the invention when $X=N$ the molecule of formula (XIV), especially (I), can be prepared by a method comprising the following steps and depicted on figure 4.

A phosphonate (Va) or a phosphoramidite (Vb) is reacted with an oligonucleotide (IV) on its 3' or 5' extremity or inside of the sequence, giving a hydrogeno-phosphonate diester (IV), wherein L, m, B have the same meaning as above.

Such Arbuzov, or Arbuzov-like, reactions have been disclosed in Meyer A. *et al.*, *Tetrahedron Letters*, **2004**, 45(19), 3745-3748 and Ferreira F. *et al.*, *Journal of Organic Chemistry*, **2005**, 70(23), 9198-9206.

Then in a second step compound (VI) is treated by carbon tetrachloride in the presence of an alkyne amine to give the phosphoramidate (I).

According to a variant of the invention when $X=O$ the molecule of formula (XIV), especially (I) can be prepared by a method comprising the following steps:

A phosphoramidite of formula (VII), especially (VIIa) and (VIIb), or (VIII), (IX) or (IXa) (figure 5) is reacted with the oligonucleotide (IV) to give directly the molecule (I).

Molecules of formula (XIII) and (III) as above disclosed are another object of the invention.

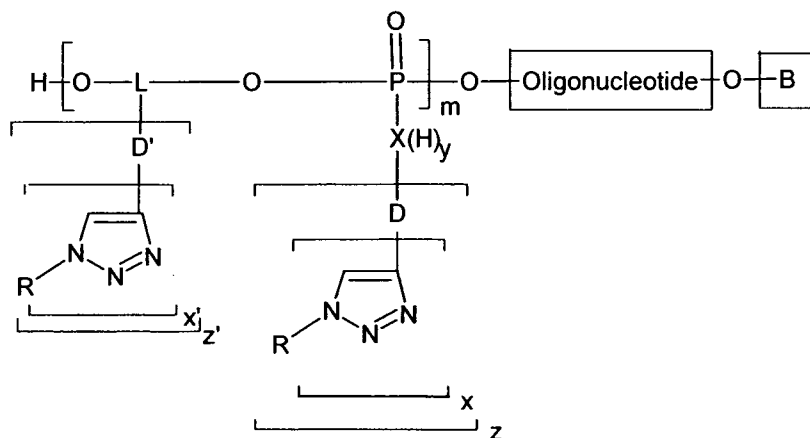

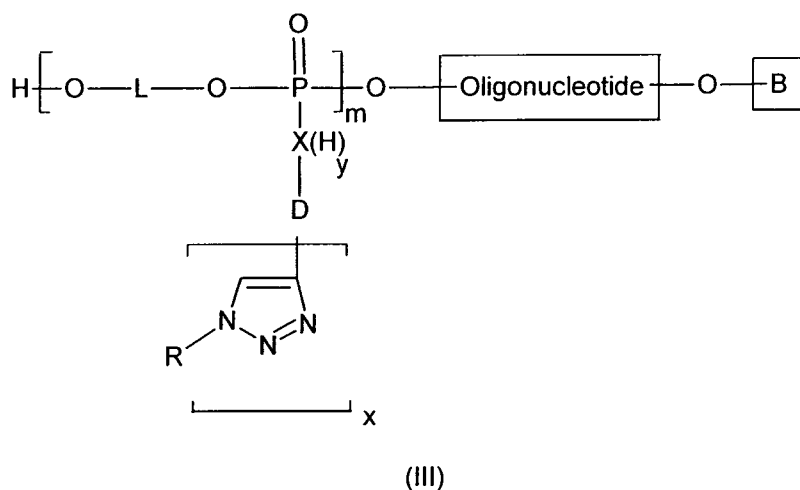

They comprise an oligonucleotide chain with at least one phosphodiester chain substitution on one of their extremities or in the chain sequence itself with one or several molecules of interest R grafted on the phosphonate group through a triazole intermediate group. They may be attached to a solid support or they can be in solution. In one molecule of formula (XIII) or (III), the different R substituents can be identical or different all along the phosphodiester chain. Preferentially R is a carbohydrate derivative, particularly preferred are molecules wherein R consists of a mono or a polysaccharide grafted on one of its extremities by a $-\text{CH}_2-(\text{CH}_2-\text{O}-\text{CH}_2)_r-\text{CH}_2-$ groups, with r an integer, $r=1, 2, 3, 4, 5, 6, \dots$

In formula (XIII) and (III), X is selected from N, O, S, an alkane di-yl comprising 1 to 12 carbon atoms, like $-\text{CH}_2-$, $-\text{CH}_2-\text{CH}_2-\dots$; preferentially X is selected from N, O;

m is an integer, $m \geq 1$

L is a linker which may be selected from the following list: alkane poly-yl functions with 1 to 12 carbon atoms, linear branched or cyclic possibly interrupted by one or several oxygen (-O-), nitrogen (-NH-, -N=) or sulphur (-S-) bridges or phosphodiester $[-\text{O}-(\text{O}^-)\text{P}(=\text{O})-\text{O}-]$ bridges; in (III) L is an alkane di-yl radical with 1 to 12 carbon atoms, linear branched or cyclic possibly interrupted by one or several oxygen (-O-), nitrogen (-NH-, -N=) or sulphur (-S-) bridges or phosphodiester $[-\text{O}-(\text{O}^-)\text{P}(=\text{O})-\text{O}-]$ bridges;

x is an integer, $30 \geq x \geq 1$

x' is an integer, $30 \geq x' \geq 1$

D is a linker between X and the carbon in position 4 of the triazole ring(s). According to the value of x, D's valency is 2 or more. Preferably D is selected from alkane poly-yl groups comprising 1 to 36 carbon atoms, possibly interrupted by one

or several oxygen (-O-), nitrogen (-NH-, -N=) or sulphur (-S-) bridges or phosphodiester [-O-(O⁻)P(=O)-O-] bridges.

According to the choice of X and D, y is 0, 1 or 2;

D' is a linker between L and the carbon in position 4 of the triazole ring(s). According to the value of x', D's valency is 2 or more. Preferably D' is selected from alkane poly-yl groups comprising 1 to 36 carbon atoms, possibly interrupted by one or several oxygen (-O-), nitrogen (-NH-, -N=) or sulphur (-S-) bridges or phosphodiester [-O-(O⁻)P(=O)-O-] bridges.

z and z' are integers, z and z' ≥ 0, at least one of z and z' is ≥ 1;

10

In formula (XIII)) and (III) B is selected from H, a solid support (array, polymer, beads) or a tag.

The oligonucleotide can be a nucleotide chain comprising 1 to 100 nucleotide units, the chain of formula (Ia) or (Ib) being grafted on its 3'-extremity, on its 5'-extremity or inside of the sequence, one P atom of the function (Ia) or (Ib) being part of the oligonucleotide chain. According to a variant illustrated on figure 12, the oligonucleotide of formula (III) or (XIII) can be an oligonucleotide derivative wherein one or several phosphate function(s) of the oligonucleotide chain has been replaced by a phosphoramidate group of the type:

20

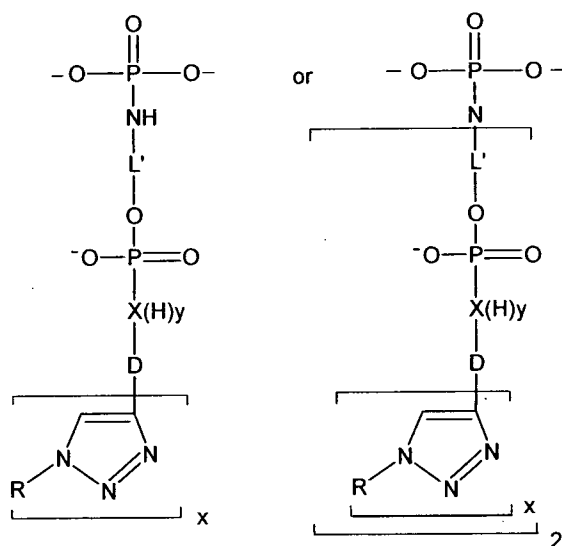

in which L' is an alkane di-yl chain comprising 1 to 12 carbon atoms. In that case, the P atom of the phosphodiester group is not part of the oligonucleotide chain, but is linked to the oligonucleotide chain through a P-NH-L'-O-P link.

25

The grafted nucleotide of formula (XIII) and (III) can be in solution (case when B=H or a tag), or it can be grafted to a solid support by one of its extremities (case when B=solid support).

Particularly, in molecules of formula (XIII) and (III), favourite variants are the following:

m is an integer selected from 1, 2, 3, 4, 5, 6.

L is a linker selected from:

5 - an alkane poly-yl (di-yl in (III)) with 1 to 12 carbon atoms, linear, branched or cyclic;

- a group $\left[\text{CH}_2\text{-CH}_2\text{-O} \right]_t \text{CH}_2\text{-CH}_2\text{-}$ with t an integer selected from 1, 2, 3, 4, 5, 6;

10 - an alkane poly-yl (di-yl in (III)) with 1 to 12 carbon atoms including an oxygen comprising heterocycle, like a ribose cycle;

D is an alkane poly-yl group comprising 1 to 12 carbon atoms possibly interrupted by one or several oxygen bridges.

15 Other known substituents can be added to this structure, like fluorescent groups which are generally introduced on the 5'-extremity of the oligonucleotide chain in a known manner.

Another object of the invention is a molecular array of formula (XIII), especially (III) consisting of a solid support grafted by a molecule as depicted above in formula (XIII) and (III) in a covalent or non covalent manner.

20 Figure 6 illustrates the method for the preparation of a 3'-substituted oligonucleotide according to the invention. According to said method a sequence of m linker grafted phosphonates is attached to a resin or any solid support by the successive addition of m linker phosphonate groups. Reaction with carbon tetra chloride and propargylamine gives the corresponding phosphoramidate and 1,3-cycloaddition of the alkyne function with azido grafted carbohydrate gives the corresponding triazole. Then supported synthesis of oligonucleotides and coupling with the phosphoramidite method gives the 3'- substituted oligonucleotide.

Repetition of this method with three different carbohydrates gave access to the molecules illustrated in figure 7.

30 The variant of figure 19 illustrates a molecule of formula (XIV) and a molecule of formula (XIII) wherein one nucleotide bears a phosphodiester chain (case wherein $z=0$ and $z'=1$).

35 Figure 19 presents a flexible synthetic approach to afford rapidly and easily Pentaerythrityl Nucleic Acids (PeNAs) based on a *bis*-2,2-saccharidyl-1,3-propanediol phosphodiester scaffold. Their synthesis was based on a combination of oligonucleotide phosphoramidite chemistry on solid support and microwave assisted click chemistry. The PeNAs were incorporating only one nucleotide at the pseudo-3'-end as a tag for the determination of glycosylated PeNAs concentration by UV analysis. The

propargylated PeNAs were conveniently prepared using a phosphoramidite dialkyne building block which was coupled several times using a DNA-like synthesis on solid support.

Another object of the invention is a method for the preparation of an oligonucleotide grafted by a molecule of interest R wherein said method comprises the step of reacting an alkyne function attached to R with an azido substituted phosphodiester derivative of the oligonucleotide, as depicted on figure 20A and 20B.

On figure 20A, the molecule of formula (XVI) is reacted with an alkyne functionalized molecule of interest (XI) to give the molecule (XV) by a click chemistry reaction in the same conditions as explained above.

On figure 20B, the molecule of formula (X) is reacted with an alkyne functionalized molecule of interest (XI) to give the molecule (XII) by a click chemistry reaction in the same conditions as explained above.

Another object of the invention is a method for the preparation of a molecule of formula (XV), or (XII), wherein said method comprises the step of reacting an alkyne function attached to R with an azide substituted phosphodiester derivative of the oligonucleotide as depicted on figure 20A and 20B.

Molecules of formula (X), (XII), (XVI) and (XV) depicted hereunder are another object of the invention:

20

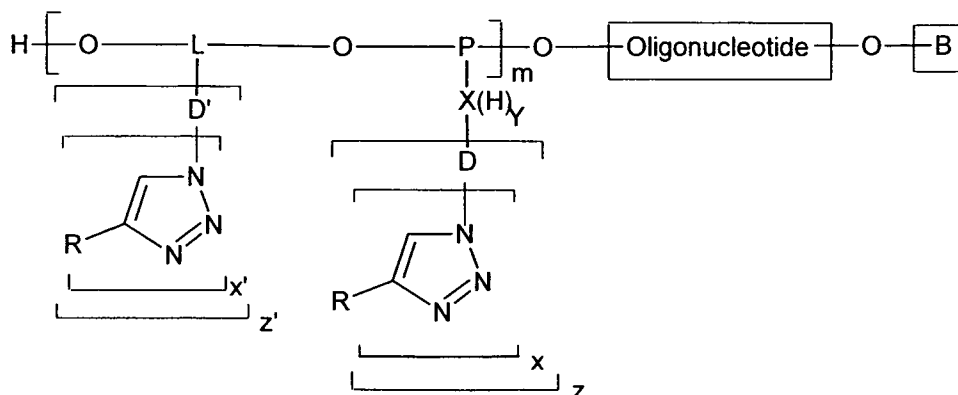
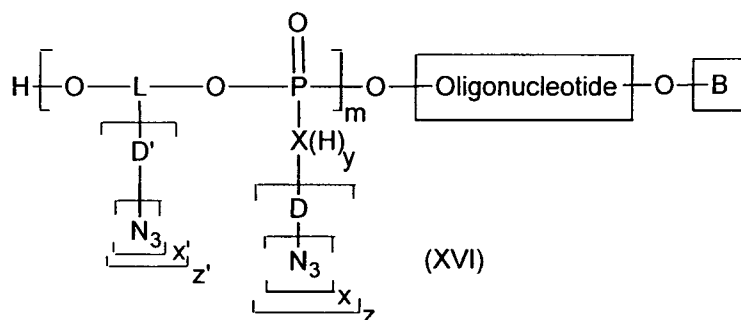

(XV)

16

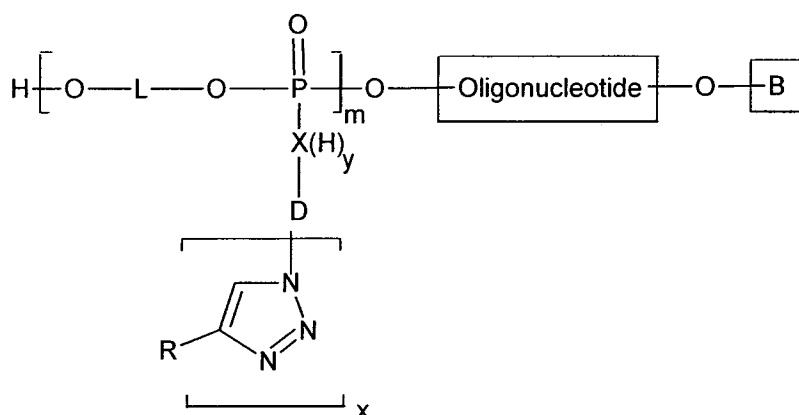
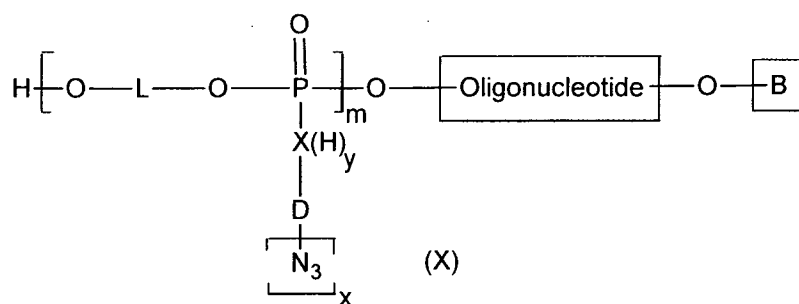

5 The variables L, X, D, B, R, m, x, y are identical to those of formula (I) and (III):

X is selected from N, O, S, an alkane di-yl comprising 1 to 12 carbon atoms, like $-\text{CH}_2-$, $-\text{CH}_2-\text{CH}_2-\dots$; preferentially X is selected from N, O;

m is an integer, $m \geq 1$

10 L is a linker which may be selected from the following list: alkane poly-yl functions with 1 to 12 carbon atoms, linear branched or cyclic possibly interrupted by one or several oxygen (-O-), nitrogen (-NH-, -N=) or sulphur (-S-) bridges or phosphodiester [-O-(O')P(=O)-O-] bridges; in (X) and (XII), L is an alkane di-yl function with 1 to 12 carbon atoms, linear branched or cyclic possibly interrupted by one or several
15 oxygen (-O-), nitrogen (-NH-, -N=) or sulphur (-S-) bridges or phosphodiester [-O-(O')P(=O)-O-] bridges;

x is an integer, $30 \geq x \geq 1$

x' is an integer, $30 \geq x' \geq 1$

20 D is a linker between X and the azide group(s) (formula (X)) or one N atom of the triazole ring (formula (XII)). According to the value of x, D's valency is 2 or more. Preferably, D is selected from alkane poly-yl groups comprising 1 to 36 carbon atoms, possibly interrupted by one or several oxygen (-O-), nitrogen (-NH-, -N=) or sulphur (-S-) bridges or phosphodiester [-O-(O')P(=O)-O-] bridges;

According to the choice of X and D, y is 0, 1 or 2;

D' is a linker between L and the azide group(s) (formula (XVI)) or one N atom of the triazole ring (formula (XV)). According to the value of x', D's valency is 2 or more. Preferably, D' is selected from alkane poly-yl groups comprising 1 to 36 carbon atoms, possibly interrupted by one or several oxygen (-O-), nitrogen (-NH-, -N=) or sulphur (-S-) bridges or phosphodiester [-O-(O')P(=O)-O-] bridges.

z and z' are integers, z and z' ≥ 0, at least one of z and z' is ≥ 1;

In formula (X), (XII), (XVI) and (XV) B is selected from H, a solid support (array, polymer, beads) or a tag.

On formula (X) and (XVI) of figure 20A and 20B, the oligonucleotide is substituted by the phosphonate chain either on its 3'-extremity, on its 5'-extremity or inside of the sequence, one P atom being part of the oligonucleotide chain. According to a variant similar to that illustrated on figure 12, the oligonucleotide of formula (X) or (XIV) can be an oligonucleotide derivative wherein one or several phosphate function(s) of the oligonucleotide chain has been replaced by a phosphoramidate group of the type:

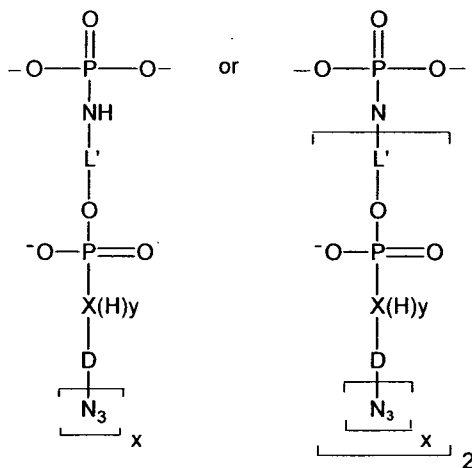

in which L' is an alkane di-yl chain comprising 1 to 12 carbon atoms.

In that case, the P atom at the extremity of the phosphodiester chain is not part of the oligonucleotide chain, but is linked to the oligonucleotide chain through a P-NH-L'-O-P link.

The grafted nucleotides of formula (X), (XII), (XIV), and formula (XV) can be in solution (case when B=H or a tag), or it can comprise a grafting to a solid support by one of its extremities (case when B=solid support).

The molecule of interest R is grafted by an alkyne function.

When the alkyne-functionalized molecule of interest (XI) is contacted with the oligonucleotide derivative (XVI), or (X) in appropriate quantity, a 1,3-dipolar cycloaddition occurs leading to the triazole (XV), respectively (XII).

This 1,3-dipolar cycloaddition is very chemoselective, only occurring between alkynyl and azido functional groups with high yields. The resulting 1,2,3-triazoles are stable at high temperature and in aqueous conditions.

5 The molecule of interest can be any molecule for which there is an interest at obtaining a condensation product with an oligonucleotide. For the sake of illustration, mention may be made of: carbohydrates, peptides, lipids, oligonucleotides, biotin, ferrocenyl compounds, fluorescent tags ...

10 It is not possible to introduce directly an azide function on a phosphoramidite group, because the P atom reacts by a Staudinger reaction with the azide function. Consequently, another strategy illustrated on figure 21 has been designed to produce molecules (X) (XII), (XVI) and (XV), which consists in introducing a Br atom (or another leaving group) on the phosphoramidite group, elongating the nucleotide chain and then substituting the Br atom by an azido function.

15 Figure 22 illustrates several Br-substituted phosphoramidite derivatives and a method to graft them on a nucleotide.

Another object of the invention is a molecular array of formula (X), (XII), (XVI) or of formula (XV) consisting of a solid support grafted by a molecule as depicted above, respectively in formula (X) (XII), (XVI) or formula (XV) in a covalent or non covalent manner.

20 Solid supports like glass plaques, glass beads or silicone plaques, resins or polymers substituted by molecules that respond to formula (III), (XIII), (XII) or (XV) are another object of the invention. Especially when R is a carbohydrate or a carbohydrate derivative such molecular arrays are of interest for the study of interactions of carbohydrates with other molecules. Carbohydrates are of a high importance in biological processes and the study of their interactions with other molecules is of high importance for understanding biological mechanisms and for designing new potential drugs. There are few methods for preparing molecular arrays comprising carbohydrate grafting and not all of them are satisfying. Molecules of formula (III) (XIII), (XII) or (XV) with B=solid support in themselves constitute such molecular arrays.

30 According to another variant, a solid support of the invention can also be an oligonucleotide microarray, on which oligonucleotides are covalently immobilized into each microreactor. Different spots with different nucleotide sequences hybridise specifically with the complementary sequence carried by the molecule responding to formula (III), (XIII), (XII) or (XV), wherein B is H or a tag. H-bonds of the Watson-Crick type are built between the nucleotides attached to the micro-array and the molecule of formula (III), (XIII), (XII) or (XV).

35 The microarrays of the invention can be used to investigate interactions between the R group of the molecules of formula (III), (XIII), (XII) or (XV) and a target,

especially a biological target. The invention is also directed to a method of investigation of interactions between the R group of the molecules of formula (III), (XIII), (XII) or (XV) and a target, especially a biological target, wherein said method comprises the step of contacting a solid support grafted by a molecule of formula (III), (XIII), (XII) or (XV) and the biological target

The method of the invention gives access to carbohydrate arrays in a simple and efficient manner. Especially, starting from a DNA array, the reactions of phosphodiester synthesis followed by the introduction of an alkyne function on phosphorus and "click reaction" with an azido-grafted carbohydrate or carbohydrate derivative is a simple sequence of operation to obtain a carbohydrate array.

The molecules of formula (III), (XIII), (XII) or (XV) can also be used for the vectorisation of an oligonucleotide to a biological target. Molecules of interest, like carbohydrates, can be selected for their specificity for a certain type of cells, so that they will help transporting the nucleotide to which they are bound to its intended target. More specifically, the invention is concerned by a method for the vectorisation of an oligonucleotide to a biological target in a subject to be treated, wherein a carbohydrate is selected for its specificity for a certain type of cells comprised in the biological target, and said carbohydrate is attached to the oligonucleotide by the method of the invention and the resultant molecule (III), (XIII), (XII) or (XV) is administered to the subject to be treated.

EXPERIMENTAL PART

Introduction

A versatile approach has been developed for the multiple labeling of oligonucleotides. First, three linkers as a *H*-phosphonate monoester derivative were condensed on a solid-supported T₁₂ to introduce *H*-phosphonate diester linkages which were oxidized in presence of propargyl amine. Secondly, three galactosyl azide derivatives were conjugated to the solid-supported three alkynes-modified T₁₂ by a 1,3-cycloaddition so called "click chemistry" in presence of Cu(I) assisted by microwaves, as illustrated on Figure 8.

According to the invention a general, simple, robust and versatile strategy for anchoring one or several carbohydrate derivative(s) to a solid-supported oligonucleotide has been conceived and performed (Figure 9). The 1,3-dipolar cycloaddition between alkynes and azides, so-called "click" chemistry (Kolb, H. C.; Finn, M. G.; Sharpless, K. B. *Angew. Chem., Int. Ed.* 2001, 40, 2004-2021 ; Bock, V. D.; Hiemstra, H.; van Maarseveen, J. H. *Eur. J. Org. Chem.* 2006, 51-68) was applied to attach carbohydrate residues to the oligonucleotide backbone. Microwave activation significantly improved the reaction kinetic compared to standard conditions. Solid-supported reactions

provided better results in terms of purity when compared to similar solution phase conditions where some phosphoramidate hydrolysis was observed.

The Huisgen's 1,3-dipolar cycloaddition between alkyne and azide is very attractive since it is nearly quantitative, can be performed in water with an organic co-solvent and multiple cycloadditions can be performed on multivalent scaffolds (Wang, Q.; Chan, T. R.; Hilgraf, R.; Fokin, V. V.; Sharpless, K. B.; Finn, M. G. *J. Am. Chem. Soc.* **2003**, *125*, 3192-3193) Furthermore, this reaction is orthogonal to most typical organic transformations and therefore highly chemoselective.

Experimental

10 1- Synthesis of solid-supported T₁₂ (2): The Solid-supported T₁₂ was synthesized using a DNA synthesizer (ABI 381A) using standard phosphoramidite chemistry on a commercially available thymidine succinyle CPG solid support (500A). Then **1** (15 molar eq., 60 mM in C₅H₅N/CH₃CN, 1:1, v/v) was coupled using a *H*-phosphonate chemistry cycle with pivaloyl chloride as activator (200 mM in
15 C₅H₅N/CH₃CN, 1:1, v/v) and 3% dichloroacetic acid in CH₂Cl₂ for the detritylation step.

2- General procedure for amidative oxidation: The solid-supported oligonucleotide (1 μmol) was treated, back and forth using two syringes, with a solution of 10 % propargylamine (100 μL) in CCl₄/C₅H₅N (900 μL, 1:1, v/v) for 30 min. The CPG beads were washed with C₅H₅N (1 mL) and MeCN (3×2 mL), and then dried by flushing
20 with nitrogen.

3- General procedure for Cu(I)-catalyzed 1,3-dipolar cycloaddition: To a solid-supported oligonucleotide (0.5 μmol) were added protected galactosyl azide **4** (10 eq, 5 μmol, 100 μL of a 50 mM solution in MeOH), CuSO₄ (0.4 eq, 0.2 μmol, 5 μL of a 40 mM solution in H₂O), freshly prepared sodium ascorbate (2 eq, 1 μmol, 20 μL of a 50 mM
25 solution in H₂O) and water (75 μL). The resulting preparation in a sealed tube was treated with a microwave synthesizer Initiator™ from Biotage set at 100 W with a 30 sec pre-mixing time. The solution was removed and the CPG beads were washed with H₂O/MeOH (2 mL, 1:1, v/v) and MeOH (1 mL) then dried.

4- General procedure for deprotection: The beads were placed into a
30 sealed vial and treated with concentrated aqueous ammonia (1 mL) for 4 h at room temperature. The beads were filtered off and the solution was evaporated. The residue was dissolved in water for subsequent analyses.

21

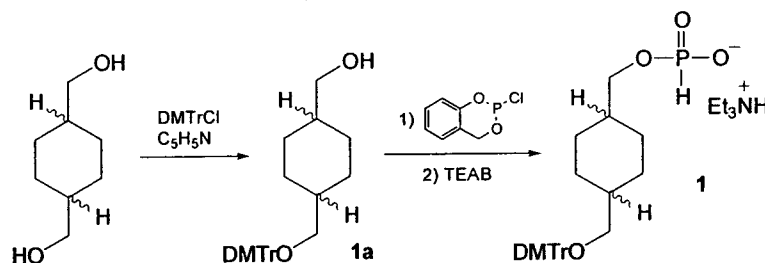
Scheme S1. Preparation of DMTr-protected *H*-phosphonate **1**

5

[4-(Dimethoxytrityloxymethyl)cyclohexyl]methanol 1a

1,4-cyclohexanedimethanol (mixture of *cis* and *trans*) (2.88 g, 20 mmol) was co-evaporated with anhydrous pyridine (2×25 mL) then taken up in pyridine (25 mL). 4,4'-dimethoxytrityl chloride (5.08 g, 15 mmol) was added in three portions over 30 minutes and the mixture was stirred at r.t. for 3 h. The solvent was evaporated and the syrupy residue was dissolved in EtOAc (200 mL). The organic layer was washed with saturated aqueous NaHCO₃ (2×50 mL) and brine (2×50 mL), dried (Na₂SO₄), and evaporated. The residue was purified by flash silica gel column chromatography (0 to 5% MeOH in CH₂Cl₂ containing 0.5% of Et₃N) to afford **1a** (4.02 g, 45%) as a pale yellow oil.

10

$R_f = 0.70$ (CH₂Cl₂/MeOH, 95:5, v/v).

15

¹H NMR (CDCl₃, 400 MHz): δ 1.02–1.93 (4m, 11H), 2.94–3.03 (m, 2H), 3.47–3.51 (m, 2H), 3.85 (s, 6H), 6.85–7.50 (m, 13H).

¹³C NMR (CDCl₃, 100 MHz): δ 25.5, 26.0, 29.1, 29.7, 36.2, 38.1, 38.8, 40.7, 55.2, 66.0, 66.2, 68.6, 68.7, 113.0, 113.2, 126.6, 127.7, 127.8, 129.2, 130.1, 136.1, 136.8, 145.5, 158.4, 158.7.

20

HRFAB (positive mode, nitrobenzyl alcohol) *m/z*: calcd for C₂₉H₃₄O₄ [M]⁺ 446.2457, found 446.2435.

Triethylammonium [4-(dimethoxytrityloxymethyl)cyclohexyl]methyl hydrogen phosphonate 1

25

30

1a (893 mg, 2 mmol) was co-evaporated with anhydrous pyridine (2×10 mL) then taken up in pyridine (10 mL) and CH₂Cl₂ (10 mL). 2-chloro-1,3,2-phosphorin-4-one (Marugg, J. E.; Tromp, M.; Kuyl-Yeheskiely, E.; van der Marel, G. A.; van Boom, J. H. *Tetrahedron Lett.* **1986**, 27, 2661-2664) (506 mg, 2.5 mmol) was added and the mixture was stirred for 2 h. 1M TEAB (20 mL) was added and the solution was stirred until the formation of CO₂ bubbles stopped. The organic layer was separated and the aqueous layer was extracted with CH₂Cl₂ (2×20 mL). The organic layers were combined, dried (Na₂SO₄) and evaporated. The residue was purified by flash silica gel column chromatography (0 to 5% MeOH in CH₂Cl₂ containing 1% of Et₃N) to afford **1** (550 mg, 45%) as a colorless oil.

$R_f = 0.15$ ($\text{CH}_2\text{Cl}_2/\text{MeOH}/\text{Et}_3\text{N}$ 89:3:8, v/v/v).

^1H NMR (CDCl_3 , 400 MHz): δ 0.82–1.73 (m, 19H), 2.94 (m, 6H), 2.75–2.84 (m, 2H), 3.51–3.58 (m, 2H), 3.63, 3.65 (2s, 6H), 6.68–7.34 (m, 13H).

^{13}C NMR (CDCl_3 , 100 MHz): δ 8.5, 25.7, 25.9, 29.2, 29.6, 36.0, 36.4, 38.6, 38.9, 45.3, 55.1, 55.2, 66.4, 66.6, 68.6, 69.2, 112.9, 113.1, 126.5, 127.0, 127.6, 127.78, 127.83, 128.2, 129.2, 130.0, 130.1, 136.67, 136.70, 145.4, 158.3, 158.6.

^{31}P NMR (CD_3CN , 80 MHz): δ 7.32, 7.60 (2s, P).

HRFAB (negative mode, nitrobenzyl alcohol) m/z : calcd for $\text{C}_{29}\text{H}_{34}\text{O}_6\text{P}_1$ $[\text{M}-\text{Et}_3\text{NH}]^-$ 509.2096, found 509.2092.

10

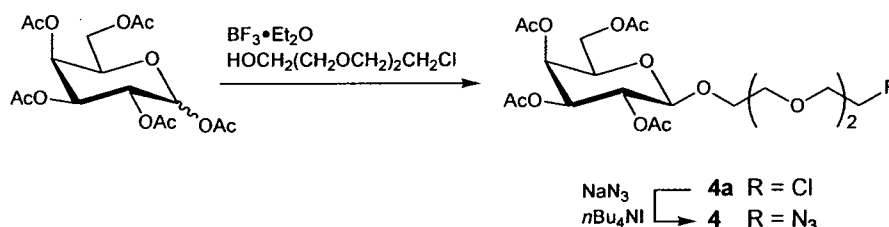

Scheme S2. Preparation of galactosyl azide **4**

1-Chloro-3,6-dioxaoct-8-yl 2,3,4,6-tetra-*O*-acetyl- β -D-galactopyranoside **4a**

15

A solution of 2-[2-(2-chloroethoxy)ethoxy]ethanol (2.80 mL, 19.2 mmol) and the peracetylated D-galactose (5 g, 12.8 mmol) in anhydrous CH_2Cl_2 (50 mL) was cooled at 0°C before dropwise addition of $\text{BF}_3 \cdot \text{Et}_2\text{O}$ (8.12 mL, 64.0 mmol). The reaction mixture was stirred at r.t. for 24 hrs then poured into saturated aqueous NaHCO_3 (300 mL). The aqueous layer was extracted with CH_2Cl_2 (2 \times 200 mL). The organic layers were combined, dried (Na_2SO_4), filtered and evaporated under reduced pressure. The oily residue was purified by flash silica gel column chromatography (PE then PE/EtOAc 3:2) to afford **4a** (Wang, J.; Zhang, B.; Fang, J.; Sujino, K.; Li, H.; Otter, A.; Hindsgaul, O.; Palcic, M. M.; Wang, P. G. *J. Carbohydr. Chem.* **2003**, *22*, 347-376) (2.93 g, 61%) as a pale yellow oil.

25

^1H NMR (CDCl_3 , 300 MHz): δ 1.99, 2.05, 2.07, 2.15 (4s, 4 \times 3H), 3.60–3.70 (m, 8H), 3.71–3.82 (m, 3H), 3.84–4.02 (m, 2H), 4.06–4.22 (m, 2H), 4.58 (d, 1H, $J_{1,2} = 8.0$ Hz), 5.02 (dd, 1H, $J_{3,4} = 3.4$ Hz, $J_{2,1} = 10.4$ Hz), 5.22 (dd, 1H, $J_{2,1} = 8.0$ Hz, $J_{2,3} = 10.4$ Hz), 5.39 (dd, 1H, $J_{4,5} = 0.9$ Hz, $J_{4,3} = 3.4$ Hz). ^{13}C NMR (CDCl_3 , 75 MHz): δ 20.6, 20.7, 20.8, 21.0, 42.7, 61.2, 67.0, 68.7, 69.0, 70.3, 70.58, 70.61, 70.63, 70.8, 71.3, 101.3, 169.4, 170.1, 170.2, 170.4.

30

1-Azido-3,6-dioxaoct-8-yl 2,3,4,6-tetra-*O*-acetyl- β -D-galactopyranoside **4**

A solution of **4a** (3.85 g, 7.71 mmol), sodium azide (2.51 g, 38.58 mmol) and $n\text{Bu}_4\text{NI}$ (5.7 g, 15.43 mmol) in anhydrous DMF (20 mL) was stirred at 90°C for 24

hrs. The solution was cooled to r.t. then diluted with EtOAc (300 mL). The organic layer was washed with water (3×200 mL), dried (Na₂SO₄), filtered and evaporated under reduced pressure. The oily residue was purified by flash silica gel column chromatography (PE then PE/EtOAc 1:1) to afford **4** (3.29 g, 85%) as a pale yellow oil.

5 ¹H NMR (CDCl₃, 300 MHz): δ 1.99, 2.04, 2.07, 2.15 (4s, 4×3H), 3.40 (t, 2H, *J* = 5.0 Hz), 3.60–3.82 (m, 9H), 3.88–4.02 (m, 2H), 4.08–4.20 (m, 1H), 4.59 (d, 1H, *J*_{1,2} = 7.9 Hz), 5.02 (dd, 1H, *J*_{3,4} = 3.4 Hz, *J*_{3,2} = 10.5 Hz), 5.21 (dd, 1H, *J*_{2,1} = 7.9 Hz, *J*_{2,3} = 10.5 Hz), 5.39 (dd, 1H, *J*_{4,5} = 0.7 Hz, *J*_{4,3} = 3.4 Hz).

10 ¹³C NMR (CDCl₃, 75 MHz): δ 20.3, 20.4, 20.5, 20.8, 50.4, 61.1, 66.8, 68.6, 68.8, 69.8, 70.1, 70.4, 70.4, 70.5, 70.7, 101.1, 169.2, 169.9, 170.0, 170.1.

HRFAB (positive mode, thioglycerol) *m/z*: calcd for C₂₀H₃₂N₃O₁₂ [M+H]⁺ 506.1986, found 506.1968. [α]_D = +1.4 (*c*=1, CH₂Cl₂).

Trigalactosylated T₁₂* **6**:

We first prepared a cyanoethyl-protected dodecathymidine (T₁₂^{*}) on solid support using well established phosphoramidite chemistry (Beaucage, S. L.; Caruthers, M. H. *Tetrahedron Lett.* **1981**, 22, 1859-1862). Then three *H*-phosphonate diester linkages were introduced using *H*-phosphonate monoester **1** to yield the modified supported oligonucleotide **2** (Figure 8). An amidative oxidation with CCl₄ in the presence of propargylamine afforded the alkyne-functionalized oligonucleotide **3** with three propargyl phosphoramidate linkages. An aliquot was treated with aqueous ammonia and analyzed by HPLC/MS to determine the efficiency of these synthetic steps (*i.e.* three *H*-phosphonate couplings and amidative oxidation). The first *H*-phosphonate coupling was not complete (86-94%) while the two subsequent couplings were higher yielding. The resulting mixture was composed of **3** (~75%), unreacted T₁₂ (~14%) and intermediates with one (~3%) and two propargyl groups (~4%) as determined by MALDI-TOF MS analyses.

Oligonucleotide **3** was then used to optimize the 1,3-dipolar cycloaddition with azide derivative **4**. The reaction proceeds slowly at room temperature and was therefore performed under microwave (MW) to shorten reaction times. Several reaction conditions under microwave activation were investigated with temperatures ranging from 60 to 100°C and reaction times from 60 to 15 min (Table 1). The cycloaddition was performed between the trivalent alkyne oligonucleotide **3** and the monovalent azide **4** with 3.3 molar eq of azide per alkyne residue in the presence of CuSO₄/sodium ascorbate (Rostovtsev, V. V.; Green, L. G.; Fokin, V. V.; Sharpless, K. B. *Angew. Chem., Int. Ed.* **2002**, 41, 2596-2599) in water/methanol to yield the solid-supported protected trigalactosylated oligonucleotide **5**. Subsequent treatment of **5** with aqueous ammonia afforded the fully deprotected trigalactosylated T₁₂ **6** in solution. The percentage of cycloaddition was determined by HPLC/MS analysis of the crude material

(Figure 10). The main peak ($R_T \sim 20$ min) corresponds to the expected trigalactosylated T_{12} **6**, the broad peak at ~ 18 min corresponds to the digalactosylated T_{12} formed from the dialkyne T_{12} , the two peaks at ~ 16 min correspond to the monogalactosylated T_{12} formed from the monoalkyne T_{12} and the peak at ~ 15 min is the T_{12} . The splitting of HPLC peak is
 5 due to the presence of diastereoisomers since the phosphorous atom of the phosphoramidate linkage is chiral. The pure trigalactosylated T_{12} **6** was easily isolated by HPLC and characterized by MALDI-TOF MS.

The results of cycloaddition are summarized in Table 1. Impurities with one and two alkynes leading to the mono- and bis-cycloadducts were not considered but
 10 proceeded with the same efficiency. It is worth pointing out that cycloaddition on the cyanoethyl protecting groups was not observed under these conditions.

Table 1. Microwave assisted 1,3-dipolar cycloaddition on solid-support of alkyne-functionalized oligonucleotide **3** (0.5 μmol) and galactosyl azide derivative **4** (5
 15 μmol , 3.3 molar eq./alkyne) with CuSO_4 (0.2 μmol) and sodium ascorbate (1 μmol) in $\text{MeOH}/\text{H}_2\text{O}$ (200 μL , 1:1, v/v) under MW activation (100W).

Entry	Temperature ($^{\circ}\text{C}$)	Time(min)	Conversion ^a	
				%
1	100	20		100
2	75	20		100
3	60	20		100
4	60	15		84 ^b
5	20 ^c	420		73

a: conversion to the triply functionalized oligonucleotide **3**. b: contaminated with one unreacted alkyne residue. c: without microwave activation.

20 The first attempt was performed at 100°C with 20 min MW activation (entry 1) and complete conversion of all three alkyne residues into the desired triazoles was observed. Decreasing the temperature to 75 then 60°C also gave a complete reaction within 20 min (entries 2 and 3). Nevertheless, conversion was not complete when the temperature was kept at 60°C and time reduced to 15 min where 16% of digalactosylated T_{12} with one
 25 remaining alkyne residue was detected by HPLC/MS (entry 4). Finally, the reaction did not reach completion (73%) even after 7h without MW activation (entry 5).

Similarly, the cycloaddition reaction was performed in solution on the T_{12} phosphodiester with three alkyne phosphoramidate linkages and was complete either

within 20 min at 75°C under MW or 18 h without MW. Nevertheless, hydrolysis of one phosphoramidate P-N bond was observed affording the corresponding phosphodiester (13% under MW and 20% without MW). No decomposition of the solid-supported oligonucleotide **5** was observed when the reaction was performed even at 100°C for 60 min under MW activation.

In conclusion, we observed a very efficient click coupling of alkyne-bearing oligonucleotide **3** with azide-functionalized galactoside **4** under MW activation at 60°C for 20 min. The reaction could be performed on solid support or in solution under similar conditions. The main advantages of the solid-supported microwave assisted click chemistry are: 1) introduction of several alkynes anywhere within the oligonucleotide backbone (*i.e.* at the 3'- or 5'-end or in the oligonucleotidic sequence) (Laurent, A.; Naval, M.; Debart, F.; Vasseur, J. J.; Rayner, B. *Nucleic Acids Res.* **1999**, *27*, 4151-4159); 2) modulation of the distance between each alkyne using different diol-type linkers between each *H*-phosphonate diester function; 3) cycloadditions can be performed with an oligonucleotide on solid support or in solution; 4) use and recovery of excess azide derivatives; 5) conjugation of various azides to an oligonucleotide using this approach; 6) rapid and high yielding multiple 1,3-dipolar cycloadditions and lack of hydrolysis of the phosphoramidate bonds.

Variant:

A variant was performed with the following dialkyne phosphoramidite which can be grafted on an oligosaccharide once or twice.

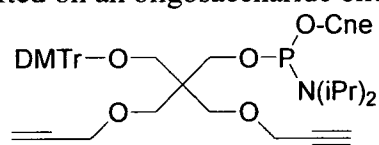

A tetramer was synthesized (figure 11) and conjugated through click chemistry with an azide sugar.

Then the oligonucleotide can be lengthened and marked with CY3.

Preparation of a molecular array:

According to the invention, DNA chips (DNA display) are used as an addressing tool for mixed DNA/Oligosaccharide molecules. We implement microreactors by etching soda-lime glass. The surfaces are functionalized and activated leading to NHS ester activated surfaces. Each type of oligonucleotide is covalently immobilized into each microreactor. Different spots with different nucleotide sequences will hybridise specifically with the complementary sequence carried by the oligosaccharide.

As illustrated in the examples above, chimeric molecules bearing an oligosaccharide moiety and an oligonucleotide have been synthesized with different valences of saccharides and different spacers. They were analysed by HPLC and characterized by MALDI-ToF.

Results: Chimeric molecules bearing up to three galactose molecules were synthesized with spacers comprising two or three TEG units or 1,4-dimethylcyclohexane. 600 microreactors of 700 μm diameter and 100 μm deep with an average roughness of 3 nm were fabricated on glass slide.

5 Oligonucleotides were immobilised via an amide bond and the chimeric molecules were locally addressed through hybridization on the solid support. Lectin recognition assays were performed and followed by scanning fluorescence.

10 **Preparation of poly alkyne functionalized phosphoester or phosphoramidate derivatives**

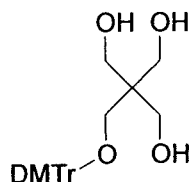

O-(4,4'-dimethoxytrityl)-pentaerythritol (7). Pentaerythritol (2.7 g, 20 mmol) was dried by co-evaporation in dry pyridine (3×10 mL) and then dissolved in dry pyridine (120 mL). Dimethoxytrityl chloride (5.42 g, 16 mmol) was added to the solution and the reaction was stirred at room temperature for 16 h. The reaction was quenched with methanol (2 mL), stirred for 10 min then poured into aqueous saturated NaHCO₃ (300 mL). The aqueous layer was extracted with CH₂Cl₂ (3×150 mL). The organic layers were combined, dried (Na₂SO₄), filtered and evaporated. The residue was purified by chromatography on silica gel (CH₂Cl₂/MeOH 99:1 to 94:6, v/v) affording the mono-dimethoxytritylated pentaerythritol 7 (2.2 g, 30%) as pale yellow foam. R_f = 0.50 (CH₂Cl₂/MeOH, 9:1, v/v). ¹H NMR (CDCl₃, 400 MHz): δ 2.36 (br s, 3H), 3.10 (s, 2H), 3.65 (br s, 6H), 3.71 (s, 6H), 6.74-7.31 (m, 13H). ¹³C NMR (CDCl₃, 100 MHz): δ 45.3, 53.5, 55.2, 63.9, 64.6, 86.5, 113.3, 127.0, 128.0, 130.0, 135.6, 144.6, 158.6.

25 Décrit dans Kim, S. J.; Bang, E.-K.; Kim, B. H. *Synlett* **2003**, 1838–1840.

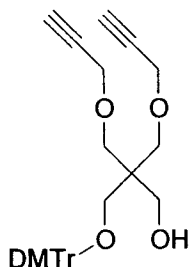

1-*O*-(4,4'-dimethoxytrityl)-2,2-bis-propargyloxymethyl-1,3-propanediol (8). Sodium hydride (1.16 g, 29.1 mmol, 60% in oil) was added at 0°C to a solution of mono-dimethoxytritylated pentaerythritol 7 (2.2 g, 4.8 mmol) in dry THF (30 mL). The reaction was stirred for 10 min before adding propargyl bromide (3.3 mL, 29.1 mmol, 80% in toluene) at rt. The resulting milky solution was stirred for an additional 3 h at rt. The solution was diluted with CH₂Cl₂ (80 mL) and the organic layer was washed with cold water (50 mL), brine (50 mL), dried (Na₂SO₄), filtered and evaporated. The residue was purified by chromatography on silica gel (CH₂Cl₂/MeOH 99.5:0.5 to 97:3, v/v) affording the dimethoxytritylated bis-propargylated pentaerythritol 2 (2.2 g, 89%) as pale yellow foam. *R_f* = 0.45 (cyclohexane/CH₂Cl₂/Et₃N, 7:2:1, v/v/v). ¹H NMR (CDCl₃, 400 MHz): δ 2.35 (m, 3H), 3.05 (s, 2H), 3.48-3.60 (m, 6H), 3.70 (s, 6H), 4.02 (s, 4H), 6.73-7.26 (m, 13H). ¹³C NMR (CDCl₃, 100 MHz): δ 11.7, 45.1, 46.3, 53.5, 55.2, 58.7, 62.3, 65.3, 70.3, 74.5, 86.0, 113.0, 113.1, 126.7, 127.8, 128.2, 129.2, 130.1, 136.0, 145.0, 158.4. HRFABMS (positive mode, nitrobenzyl alcohol) *m/z*: calcd for C₃₂H₃₄O₆ [M + H]⁺ 514.2355, found 514.2365

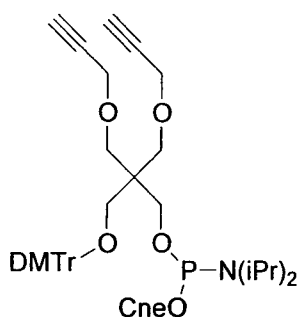

1-*O*-(4,4'-dimethoxytrityloxy)-2,2-bis-propargyloxymethyl-3-{*O*-[(2-cyanoethyl)-*N,N*-diisopropyl-phosphoramidite]-1,3-propanediol (9). 1-*O*-(4,4'-dimethoxytrityl)-2,2-bis-propargyloxymethyl-1,3-propanediol 8 (680 mg, 1.32 mmol) and diisopropylammonium tetrazolide (113 mg, 0.66 mmol) were dried three times by co-evaporation with anhydrous acetonitrile then dissolved in anhydrous CH₂Cl₂ (8 mL) before addition of 2-cyanoethyl tetraisopropylphosphorodiamidite (503 μL, 1.58 mmol) at rt. The resulting mixture was stirred at room temperature for 3 h then diluted with EtOAc (50 mL). The organic layer was washed with brine (2×100 mL), dried (Na₂SO₄), filtered and evaporated. The residue was purified by chromatography on silica gel (Cyclohexane/CH₂Cl₂ 100/0 to 80/20 with 4% Et₃N) affording the phosphoramidite 9 (800 mg, 85%) as an oil. *R_f* = 0.60 (Cyclohexane/CH₂Cl₂/Et₃N, 7:2:1, v/v/v). ¹H NMR (CDCl₃, 200 MHz): δ 1.15-1.24 (m, 12H), 2.40 (m, 2H), 2.54 (t, 2H, *J* = 6.5 Hz), 3.15 (br s, 2H), 3.45-3.74 (m, 10H), 3.81 (s, 6H), 4.09-4.12 (m, 4H), 6.76-7.49 (m, 13H). ¹³C NMR (CDCl₃, 100 MHz): δ 20.3, 20.4,

24.6, 24.6, 26.92, 26.93, 29.7, 30.2, 30.3, 43.0, 43.1, 43.5, 45.5, 45.6, 46.3, 53.4, 55.2, 58.2, 58.4, 58.6, 58.7, 61.2, 62.2, 62.4, 69.4, 74.1, 74.2, 80.0, 85.6, 112.9, 117.7, 126.6, 127.6, 128.3, 130.3, 136.3, 145.3, 158.3. ^{31}P NMR (CDCl_3 , 80 MHz): δ 148.6. HRFABMS (positive mode, nitrobenzyl alcohol) m/z : calcd for $\text{C}_{41}\text{H}_{52}\text{O}_7\text{N}_2\text{P}_1$ $[\text{M} + \text{H}]^+$
 5 715.3512, found 715.3522.

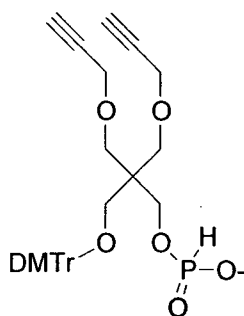

1-O-(4,4'-dimethoxytrityloxymethyl)-2,2-bis-propargyloxymethyl-3-O-(H-phosphonate monoester triethylammonium)-1,3-propanediol (10).

1-O-(4,4'-dimethoxytrityl)-2,2-bis-propargyloxymethyl-1,3-propanediol
 10 (8) (514 mg 1 mmol) was dried by co-evaporation in dry pyridine (3×5 mL) and then dissolved in dry pyridine (6 mL). Diphenylphosphite (1.4 mL 7 mmol) was added and the solution was stirred at RT for 60 min. Then the mixture was cold down (5°C) and a solution of water and triethylamine (5 mL, 1:1, v/v) was added. The resulting solution was stirred for 45 min at RT. The product was poured in a separatory funnel containing
 15 aqueous saturated NaHCO_3 , and extracted with CH_2Cl_2 (3 x 50 mL). Organic layer was dried over anhydrous Na_2SO_4 , and evaporated to dryness under reduced pressure. The residue was purified by flash chromatography on silica gel using an increasing amount of methanol (0 to 7%) in CH_2Cl_2 containing 4% of Et_3N .

530 mg, 78%
 20 Rf: 0.30 CH_2Cl_2 , MeOH, Et_3N , (92.5:5:2.5, v/v/v),
 ^1H NMR (CD_3CN , 400 MHz): δ 1.22 (t, 7.3 Hz 9H, $\text{CH}_3\text{-CH}_2$), 2.73 (s, 3H, HC), 2.97 (q 7.3Hz, 6H, $\text{CH}_3\text{-CH}_2$), 3.04 (s, 2H, CH_2ODMTr), 3.55 (s, 4H, $\text{CH}_2\text{-Opropargyl}$), 3.73 (d, 6.2Hz, 2H CH_2OP), 3.79 (s, 6H, OCH₃), 4.10 (d, 2.4Hz, 4H, OCH₂C), 6.56 (d, JHP=598Hz, 1H, HP), 6.87-7.48 (m, 13H arom)
 25 ^{13}C NMR (CD_3CN , 100 MHz): δ 7.95, 45.3, 54.9, 58.3, 61.4, 62.3, 69.1, 74.8, 80.0, 85.5, 112.9, 126.7, 127.8, 128.1, 130.1, 136.2, 145.5, 158.6.
 ^{31}P NMR (CDCl_3 , 80 MHz): δ 7.1.

HRFABMS (negative mode, nitrobenzyl alcohol) m/z : calcd for $\text{C}_{32}\text{H}_{34}\text{O}_8\text{P}_1$ $[\text{M} - \text{H}]^-$, 577.1991 found 577.1975.
 30

29

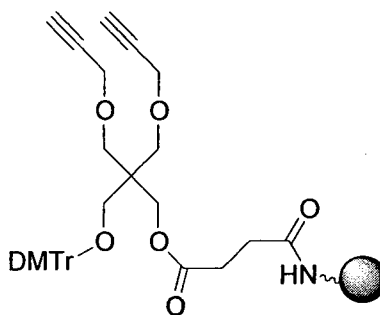

1-O-(4,4'-dimethoxytrityloxymethyl)-2,2-bis-propargyloxymethyl-3-O-(succinic-LCAA CPG)-1,3-propanediol (11).

5 (LCAA-CPG 500 Å, 80-120 mesh, 80-90 µmol/g)
 LCAA-CPG (1.00 g), 1-O-(4,4'-dimethoxytrityl)-2,2-bis-propargyloxymethyl-1,3-propanediol **8** (0.114 g, 0.2 mmol), EDC (0.191 g, 1 mmol), DMAP (0.012 g, 0.1 mmol), Et₃N (0.1 ml) were shaken in anhydrous pyridine (5 ml) at room temperature for 48 hours. Then pentachlorophenol (135 mg, 0.5 mmol) was added
 10 and the mixture was shaken for 10h. Piperidine (5 mL) was added and after 5 min of shaking the solid support was filtered off, washed with CH₂Cl₂ and dried. A capping step with standard Cap A and Cap B solutions was applied for 2 hour and the solid support was filtered off, washed with CH₂Cl₂ and dried. Trityl assay indicated a loading of 40 µmol/g.

15 Serie 1,1,1-Tris(hydroxymethyl)ethane.

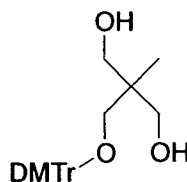

1-O-(4,4'-dimethoxytrityl)-2-hydroxymethyl-2-methyl-1,3-propanediol (16)

20

Same protocol than for 7.

1.9g, 56%

R_f = 0.28 (CH₂Cl₂/MeOH, 19:1, v/v).

25

¹H NMR (CDCl₃, 400 MHz): δ 0.87 (s, 3H, CH₃), 2.42 (br s, 2H, OH), 3.16 (s, 2H, DMTrO-CH₂-), 3.69 (d, 2H, AB_{sys}J=25.2Hz -CH_{2a}OH) 3.64 (d, 2H, AB_{sys}J=25.2Hz -CH_{2b}OH), 3.82 (s, 6H, OCH₃), 6.79-7.49 (m, 13H, arom.).

¹³C NMR (CDCl₃, 100 MHz): 17.4, 41.1, 55.2, 67.2, 68.2, 86.3, 113.3, 126.9, 128.0, 130.0, 135.8, 144.7, 158.5.

HRFABMS (positive mode, nitrobenzyl alcohol) m/z : calcd for $C_{26}H_{30}O_5$ $[M + H]^+$ 422.2093, found 422.2098.

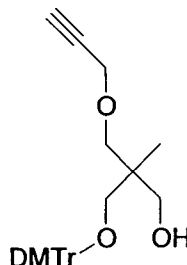

5 **1-O-(4,4'-dimethoxytrityl)-2-propargyloxymethyl-2-methyl-1,3-propanediol (17)**

1-O-(4,4'-dimethoxytrityl)-2-hydroxymethyl-2-methyl-1,3-propanediol **16** (620 mg, 1.47 mmol) was dissolved in anhydrous THF (6 mL) and sodium hydride (60% in oil, 590mg, 14.7 mmol) was added. After 10 min stirring, propargyl bromide (80% in toluene, 650 mL, 5.9 mmol) was added and the mixture was stirred at RT for 1h. Then CH_2Cl_2 was added (100 mL) and 2 mL of water. Organic layer was washed with water (2 x 100 mL) and dried over Na_2SO_4 . After evaporation the residue was purified by flash chromatography using an increasing amount of ethyl acetate (10% to 50%) in cyclohexane containing 1% of triethylamine.

500mg 74%

1H NMR ($CDCl_3$, 200 MHz): δ 0.95 (s, 3H, CH_3), 2.58 (t, 1H, CCH), 2.60 (br s, 1H, OH), 3.03 (d, AB_{sys} J= 20.7 Hz, 1H, $CH_{2a}O$ -propargyl) 3.13 (d, AB_{sys} J= 20.7 Hz, 1H, $CH_{2b}O$ -propargyl) 3.58-3.6 (m, 2H, $-CH_2OH$), 3.65 (s, 2H, DMTrO- CH_2 -), 3.82 (s, 6H, OCH_3), 4.18 (dd, J=0.9 and 1.4Hz, 2H, CH_2 -CCH), 6.85-7.54 (m, 13H, arom.).

^{13}C NMR ($CDCl_3$, 100 MHz): 17.8, 40.8, 55.2, 58.7, 66.5, 68.9, 74.3, 74.5, 79.7, 86.0, 113.2, 126.7, 127.8, 128.1, 129.1, 130.1, 136.0, 145.0, 158.4.

HRFABMS (positive mode, nitrobenzyl alcohol) m/z : calcd for $C_{29}H_{32}O_5$ $[M + H]^+$ 460.2250, found 460.2248.

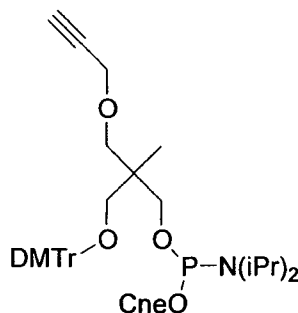

1-*O*-(4,4'-dimethoxytrityloxymethyl)-2-propargyloxymethyl-2-methyl-3-*O*-[(2-cyanoethyl)-*N,N*-diisopropyl-phosphoramidite]-1,3-propanediol (18)

5 Same protocol than for **9** was applied starting from 325 mg 0.7 mmol of **17** gave 422 mg 92%.

¹H NMR (CDCl₃, 200 MHz): δ 1.00-1.21 (m, 15H, CH₃), 2.42 (bs, 1H, CCH), 2.53-2.59 (t, 2H, *J* = 6.5 Hz, -CH₂CN), 3.03 (s, 2H, OCH₂DMTr), 3.43-3.79 (m, 8H, OCH₂-, CH, CH₂OP, CH₂Opropargyl), 3.82 (s, 6H, OCH₃), 4.11-4.18 (bs, 2H, OCH₂CC), 6.83-7.49 (m, 13H).

10 ¹³C NMR (CDCl₃, 100 MHz): δ 17.8, 20.3, 24.5, 24.6, 41.2, 41.3, 43.2, 43.3, 53.3, 55.2, 58.3, 58.5, 58.6, 58.7, 65.2, 66.5, 66.6, 66.7, 72.8, 72.9, 73.9, 80.2, 85.7, 113.0, 117.4, 126.5, 127.6, 128.4, 130.2, 136.5, 145.3, 158.5.

³¹P NMR (CDCl₃, 80 MHz): δ 148.6, 148.7.

15 HRFABMS (positive mode, nitrobenzylic alcohol) *m/z*: calcd for C₃₈H₅₀N₂O₆P₁ [M + H]⁺ 661.3383, found 661.3383.

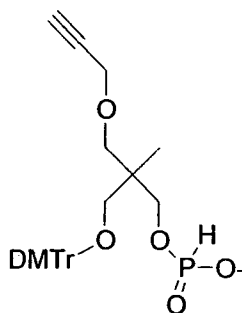

20 **1-*O*-(4,4'-dimethoxytrityloxymethyl)-2-propargyloxymethyl-2-methyl-3-*O*-(H-phosphonate monoester triethylammonium)-1,3-propanediol (19).**

Same protocol than for **10** starting from **17**

Rf: 0.30 CH₂Cl₂, MeOH, Et₃N, (92.5:5:2.5, v/v/v),

25 ¹H NMR (CD₃CN, 300 MHz): ¹H NMR (CDCl₃, 200 MHz): δ 1.00 (s, 3H, CH₃), 2.75 (s, 1H, CCH), 3.03 (s, 2H, OCH₂DMTr), 3.43-3.79 (m, 8H, OCH₂-, CH₂OP, CH₂Opropargyl), 3.79 (s, 6H, OCH₃), 4.11 (bs, 2H, OCH₂CC), 6.58 (d, *J* HP=595Hz, 1H, HP), 6.87-7.47 (m, 13H).

30 ³¹P NMR (CDCl₃, 80 MHz): δ 2.4.

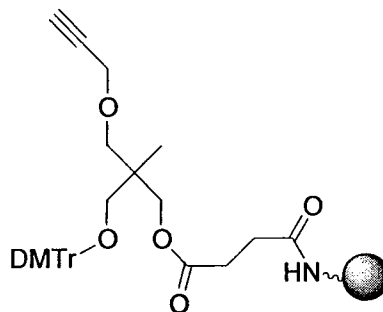

5 **1-O-(4,4'-dimethoxytrityloxymethyl)-2-propargyloxymethyl-2-methyl-3-O-(succinic-LCAA CPG)-1,3-propanediol (20).**

Same protocol than for 11. Loading 32.2 $\mu\text{mol/g}$ for LCAA CPG 500 Å and 30.1 $\mu\text{mol/g}$ for LCAA CPG 1000 Å

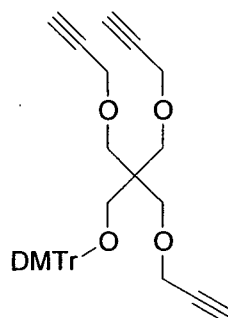

***O*-(4,4'-dimethoxytrityl)-tris-*O*-propargyl pentaerythritol. (12)**

5 Sodium hydride (200 mg, 5.0 mmol, 60% in oil) was added to 1-*O*-(4,4'-
 dimethoxytrityl)-2,2-bis-propargyloxymethyl-1,3-propanediol (**8**) (514 mg, 1.0 mmol)
 dissolved in dry THF (8 mL) and cold at 0°C. The reaction was stirred for 10 min before
 adding propargyl bromide (0.57 mL, 5.0 mmol, 80% in toluene). The resulting milky
 solution was heated at 55°C for 40h. The solution was diluted with CH₂Cl₂ (8 mL) and the
 10 organic layer was washed with cold water (30 mL), brine (30 mL), dried (Na₂SO₄), filtered
 and evaporated. The residue was purified by chromatography on silica gel
 (Cyclohexane/CH₂Cl₂/Et₃N 80:18:2 to 75:22:2, v/v/v) affording the tris-propargylated
 pentaerythritol **12** (480 mg, 86%). *R_f* = 0.451 (cyclohexane/CH₂Cl₂/Et₃N, 6:4:1, v/v/v). ¹H
 NMR (CDCl₃, 200 MHz): δ 2.50 (t, J2.4Hz, 3H, HC), 3.12 (s, 2H, CH₂-ODMTr), 3.57 (s,
 15 6H, -CH₂Opropargyl), 3.82 (s, 6H, CH₃O-), 4.09 (s, 6H, O-CH₂-CCH), 6.82-7.50 (m,
 13H, arom).

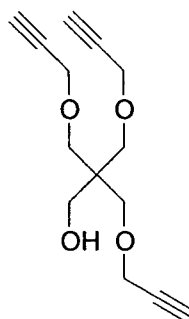

CAS 779349-07-4

Calvo-Flores, F. G. et al., *Organic Letters* 2, (2000) 2499-2502.

20

***O*-tris-propargyl-pentaerythritol. (13)**

To a solution of *O*-(4,4'-dimethoxytrityl)-tris-*O*-propargyl pentaerythritol
 (**12**) (480 mg, 0.87 mmol) in CH₂Cl₂/MeOH (7:3, v/v) was added 4mL of 10% *para*-
 25 toluenesulfonic acid in CH₂Cl₂/MeOH (7:3, v/v) and the solution was stirred for 30 min.
 Then 1.6g of polyvinylpyridine was added and the heterogeneous colourless mixture was
 stirred for 15 min. The resin was filtered off and washed with 15 mL of CH₂Cl₂/MeOH

(7:3, v/v). After evaporation the oil was purified by silica gel chromatography using cyclohexane with an increasing amount of ethyl acetate (0-50%), 100 mg 47%.

^1H NMR (CDCl_3 , 200 MHz): δ 2.50 (t, J2.4Hz, 3H, HC), 3.59 (s, 6H, - $\text{CH}_2\text{Opropargyl}$), 3.72 (s, 2H, CH_2OH), 4.16 (d, J2.4Hz, 6H, O- $\text{CH}_2\text{-CCH}$).

5

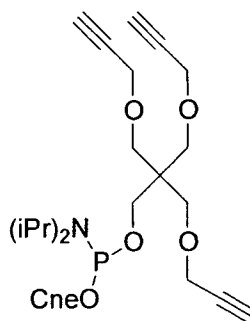

***O*-tris-propargyl-*O*-[(2-cyanoethyl)-*N,N*-diisopropyl-phosphoramidite]-pentaerythritol. (14)**

10 Same protocol than for **9** was applied starting from 100mg 0.4 mmol of
13.

120 mg, 79%. Rf: 0.65 (Cyclohexane/ $\text{CH}_2\text{Cl}_2/\text{Et}_3\text{N}$, 74:25:1, v/v/v). ^1H
15 NMR (CDCl_3 , 400 MHz): δ 1.18-1.20 (dd, J=1.9Hz and 6.8Hz 12H, CH_3 -) 2.41 (t, J=2.4Hz, 3H, HC), 2.65 (td, J= 1.9Hz and 6.5Hz, 2H, - CH_2CN), 3.53 (s, 6H, - $\text{CH}_2\text{Opropargyl}$), 3.55-3.67 (m, 4H, O- CH_2CH_2 , CH, 3.81-3.89 (m, CH_2OP), 3.72 (s, 2H, CH_2OH), 4.13 (d, J=2.4Hz, 6H, O- $\text{CH}_2\text{-CCH}$). ^{13}C NMR (CDCl_3 , 400 MHz): δ 20.4, 24.6, 24.7, 43.2, 45.2, 58.3, 58.4, 58.7, 62.3, 68.6, 74.2, 80.0, 117.7. ^{31}P NMR (CDCl_3 , 80 MHz): δ 150.0. HRFABMS (positive mode, nitrobenzyl alcohol) m/z : calcd for $\text{C}_{20}\text{H}_{31}\text{O}_4\text{N}_1\text{P}_1$ $[\text{M} + \text{H}]^+$ 380.1991, found 380.1975.

20

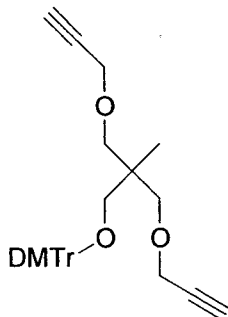

1,3-*O*-bis-propargyl-2-[*O*-(4,4'-dimethoxytrityloxymethyl)oxymethyl]-2-methyl-1,3-propanediol (21).

25

Same protocol than for **12** starting from **16**.

35

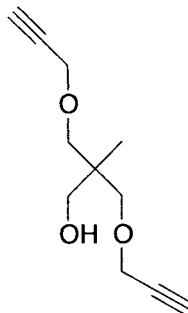

5

1,3-O-bis-propargyl-2-hydroxymethyl-2-methyl-1,3-propanediol (22).

10

Same protocol than for 13 starting from 21.

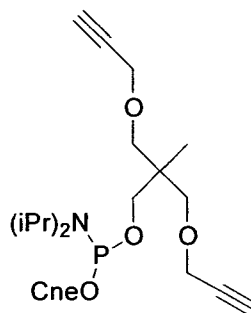

15

1,3-O-bis-propargyl-2-[(2-cyanoethyl)-N,N-diisopropylphosphoramidite]oxymethyl-2-methyl-1,3-propanediol (23).

20

Same protocol than for 14 starting from 22.

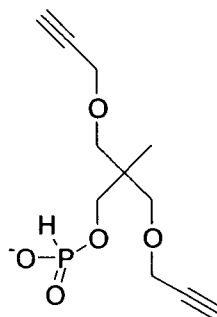

25

1,3-O-bis-propargyl-2-(H-phosphonate monoester triethylammonium)]oxymethyl]-2-methyl-1,3-propanediol (24).

5

Same protocol than for **19** starting from **22**.

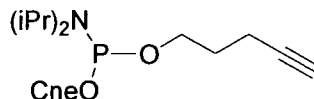

10

***O*-[(2-cyanoethyl)-*N,N*-diisopropyl-phosphoramidite] 4-propyn-1-ol (25)**

4-propyn-1-ol (151 mg, 1.8 mmol) and 2-cyanoethyl tetraisopropylphosphorodiamidite (0.57 mL, 1.8 mmol) was coevaporated twice in dry acetonitrile. The residue was dissolved in dry CH₂Cl₂ (3 mL) and diisopropylammonium tetrazolide (154 mg, 0.9 mmol) was added. After 5h of stirring at RT the solution was diluted with CH₂Cl₂ (50 mL) and the solution was washed with brine (2 x 100 mL). The organic layer was dried over Na₂SO₄ and evaporated to provide a pale yellow oil. The compound was purified by flash chromatography on silica gel using an increasing amount of CH₂Cl₂ in cyclohexane containing 5% of Et₃N.

20

350 mg, 68%.

Rf: 0.48 (Cyclohexane/CH₂Cl₂/Et₃N, 5:4:1, v/v/v). ¹H NMR (CDCl₃, 200 MHz): δ 1.20 (d, J=7.2 Hz 12H, CH₃-), 1.84 (quint, J=6.6 Hz, 2H, -CH₂-CH₂CCH), 1.96, (t, J= 2.7HZ, 1H, CCH), 2.32(td, J=2.7 and 7.1Hz, 2H, CH₂-CCH) 2.65 (t, J=6.5Hz, 2H, CH₂CN), 3.55-3.88 (m, 6H, PO-CH₂ and CHMe₂). ¹³C NMR (CDCl₃, 400 MHz): δ 15.1, 20.4, 24.6, 30.1, 43.0, 58.3, 61.9, 68.5, 83.7, 117.6. ³¹P NMR (CDCl₃, 80 MHz): δ 148.8.

25

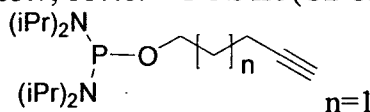

30

4-propyn-1-ol tetraisopropylphosphorodiamidite (27)

To a solution of 4-propyn-1-ol (95 μL, 1.0 mmol) and Et₃N (278 mL, 2 mmol) in dry diethylether (2.5 mL), bis(diisopropylamino)chlorophosphine (267 mg, 1mmol) was added and stirred for 2h at RT. The solution was diluted with diethylether:triethylamine (9:1, v/v, 10 mL) and the salts were removed by filtration and washed. The solution was evaporated to the half and cyclohexane was added. Diethylether

35

was removed by evaporation keeping cyclohexane. The solution was applied on a silica gel column (25g) and the compound was purified using cyclohexane containing 6% of Et₃N.

280 mg, 89%.

- 5 Rf: 0.60 (Cyclohexane/CH₂Cl₂/Et₃N, 6:3:1, v/v/v). ¹H NMR (CDCl₃, 200 MHz): δ 1.20 (dd, J=10.4 and 13.0 Hz 24H, CH₃-), 1.83 (quint, J=6.6 HZ, 2H, -CH₂-CH₂CCH), 1.95, (t, J= 2.6HZ, 1H, CCH), 2.32 (td, J=2.6 and 7.1Hz, 2H, CH₂-CCH), 3.44-3.77 (m, 6H, PO-CH₂ and CHMe₂). ¹³C NMR (CD₃CN, 400 MHz): δ 14.9, 23.4, 24.1, 30.5, 44.2, 62.4, 68.7, 83.9, 117.1. ³¹P NMR (CD₃CN, 80 MHz): δ 125.0.

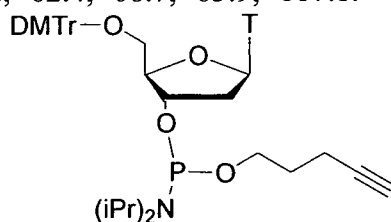

10

5'-O-Dimethoxytrityl-3'-O-[(4-propynyl)-N,N-diisopropylphosphoramidite] thymidine (28)

- 15 Dry 5'-O-Dimethoxytrityl-thymidine (544.5, 1mmol) and dry diisopropylammonium tetrazolide (86 mg, 0.5 mmol) were dissolved in dry CH₂Cl₂ (8 mL), and 4-propyn-1-ol tetraisopropylphosphorodiamidite (377 mg, 1.2 mmol) was added. After 3h of stirring the solution was diluted with ethyl acetate (80 mL) and the solution was washed with brine (2 x 150 mL). The organic layer was dried over Na₂SO₄ and evaporated. The compound was purified by flash chromatography on silica gel using an
- 20 increasing amount of CH₂Cl₂ (14 to 44%) in cyclohexane containing 6% of Et₃N.

650 mg, 85%

Rf: 0.50 (Cyclohexane/CH₂Cl₂/Et₃N, 5:4:1, v/v/v).

- 25 ¹H NMR (CDCl₃, 200 MHz): δ 1.07 (d, J=6.7, 3H, CH₃-), 1.18(d, J=6.8Hz, 9H, CH₃), 1.43(bs, 3H, CH₃T), 1.70-2.03 (m, 3H, CCH, -CH₂-CH₂CCH), 2.20-2.36 (m, 4H, H₂',H₂'', CH₂-CCH), 3.50-3.71 (m, 6H, H₅',H₅'',O-CH₂), 3.81 (s, 3H, OCH₃), 4.17-4.22 (m, 1H, H₄') 4.65-4.68 (m, 1H, H₃'), 6.43-6.45 (m, 1H, H₁'), 6.83-7.45 (m, 13H, arom), 7.68 (d, 1H, H₆), 8.50 (bs, 1H, NH). ¹³C NMR (CD₃CN, 400 MHz): δ 11.7, 15.1, 23.0, 24.5, 26.9, 30.0, 40.3, 43.1, 55.3, 61.9, 63.2, 68.7, 83.7, 84.8, 85.5, 85.9,
- 30 86.9, 111.2, 113.3, 127.2, 128.0, 128.2, 130.2, 135.3, 135.5, 135.7, 144.3, 150.4, 158.7, 163.9. ³¹P NMR (CD₃CN, 80 MHz): δ 148.3 and 148.7.

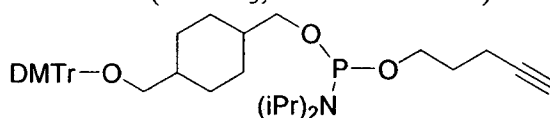

1-O-[(4-propynyl)-*N,N*-diisopropyl-phosphoramidite]-4-O-(Dimethoxytrityloxymethyl)cyclohexyl]methanol (29)

5 Same protocol than for **28** starting from 4-(Dimethoxytrityloxymethyl)cyclohexyl]methanol (332 mg, 0.74 mmol) afforded 450 mg 92%.

Rf: 0.17 (Cyclohexane/CH₂Cl₂/Et₃N, 7:2:1, v/v/v)

10 ¹H NMR (CDCl₃, 200 MHz): δ 1.17-1.22 (d, 12H, CH₃), 1.46-1.83 (m, 13H, CCH, cyclohexane, OCH₂CH₂CH₂-), 2.29-2.34 (m, 2H, CH₂CC), 2.89-2.92 (m, 2H, CH₂-DMTr), 3.32-3.77 (m, 6H, CHMe₂, CH₂-cyclohexane, OCH₂CH₂-), 3.82 (s, 6H, CH₃O), 6.83-7.50 (m, 13H, arom), ¹³C NMR (CD₃CN, 400 MHz), 14.5, 24.0, 25.4, 25.9, 26.7, 29.1, 29.5, 30.1, 36.0, 36.7, 38.6, 39.5, 42.6, 42.7, 54.9, 61.4, 61.6, 66.0, 68.6, 68.9, 83.9, 85.4, 112.9, 117.3, 126.6, 127.7, 128.1, 130.0, 136.6, 145.7, 158.5, ³¹P NMR
15 (CD₃CN, 80 MHz): δ 147.1

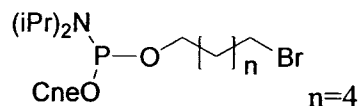

20 **O-[(2-cyanoethyl)-*N,N*-diisopropyl-phosphoramidite] 6-bromo-hexan-1-ol (31)**

Same protocol than for **25** starting from 6-bromo-hexanol 325 mg 1.8 mmol gave 400mg 60%.

25 ¹H NMR (CDCl₃, 200 MHz): δ 1.17-1.21 (d, 12H, CH₃), 1.44-1.88 (m, 8H, CH₂), 2.62-2.69 (m, 2H, CH₂CN), 3.39-3.87 (m, 8H, CH₂O, CH₂Br, CHMe₂), ³¹P NMR (CD₃CN, 80 MHz): δ 148.5 ppm

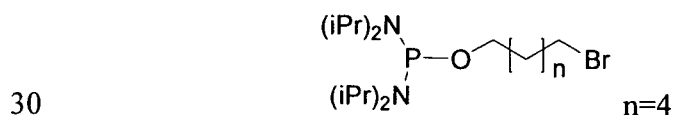

6-bromo-hexan-1-ol tetraisopropylphosphorodiamidite (32)

Same protocol than for **27** starting from 6-bromo-hexanol 271.6 mg 1.5 mmol gave 410mg 90%.

^1H NMR (CDCl_3 , 200 MHz): δ 1.16-1.20 (dd, 24H, CH_3), 1.42-1.47 (m, 4H, CH_2), 1.56-1.65 (m, 2H, $\text{CH}_2\text{CH}_2\text{Br}$), 1.85-1.92 (m, 2H, OCH_2CH_2), 3.39-3.62 (m, 8H, CH_2O , CH_2Br , CHMe_2), ^{31}P NMR (CDCl_3 , 80 MHz): δ 125.3 ppm

5

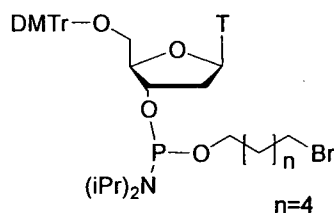

5'-O-(4,4'-dimethoxytrityl) 3'-O-[(6-bromohexyl) N,N-diisopropylamino phosphoramidite] thymidine **33**

10 Same protocol than for **28** starting from 5'-(Dimethoxytrityloxymethyl)thymidine (300 mg, 0.54 mmol) and using 6-bromo-hexan-1-ol tetraisopropylphosphorodiamidite (**32**) afforded 377 mg 82%.

^1H NMR (CDCl_3 , 200 MHz): δ 1.4-1.20 (m, 12H, CH_3), 1.36-1.88 (m, 9H, CH_3T , $-\text{CH}_2-$), 2.50-2.65 (m, 2H, $\text{H}_2'\text{H}_2''$), 3.35-3.7 (m, 8H, $\text{H}_5'\text{H}_5''$, CHMe_2 , CH_2),
 15 3.81 (s, 6H, $\text{CH}_3\text{O}-$), 4.17-4.22 (m, 1H, H_4'), 4.61-4.69 (m, 1H, H_3'), 6.40-6.46 (m, 1H, H_1'), 6.83-7.67 (m, 14H, H_6 , arom), ^{31}P NMR (CDCl_3 , 80 MHz): δ 147.8 and 148.3

Pentaerythrityl Nucleic Acids (PeNAs)

20 PeNAs based on a *bis*-2,2-saccharidyl-1,3-propanediol phosphodiester scaffold were prepared following the scheme hereunder:

The synthesis was based on a combination of oligonucleotide phosphoramidite chemistry on solid support and microwave assisted click chemistry. The PeNAs were incorporating only one nucleotide at the pseudo-3'-end as a tag for the determination of glycosylated PeNAs concentration by UV analysis. The propargylated
 25 PeNAs were conveniently prepared using a phosphoramidite dialkyne building block which was coupled several times using a DNA-like synthesis on solid support (figure 24). Carbohydrate moieties (figure 23) were then introduced from their azide derivatives by 1,3-dipolar cycloaddition ((a) Kolb, H. C. et al., *Angew. Chem. Int. Ed.* **2001**, *40*, 2004–2021 ; (b) Calvo-Flores, F. G. et al., *F. Org. Lett.* **2000**, *2*, 2499–2502. (c) Pérez-Balderas,
 30 F. et al., *Org. Lett.* **2003**, *5*, 1951–1954. (d) Chen, Q. et al., *Carbohydr. Res.* **2005**, *340*, 2476–2482. (e) Chittaboina, S. et al., *Tetrahedron Lett.* **2005**, *46*, 2331–2336. (f) Giguère, D. et al., *Chem. Commun.* **2006**, 2379–2381. (g) Fernandez-Megia, E. et al., *R. Macromolecules* **2006**, *39*, 2113–2120. (h) Tejlera, J. et al., *Carbohydr. Res.* **2006**, *341*, 1353–1362) according to our previously reported procedure ((a) Bouillon, C. et al., *J. Org. Chem.* **2006**, *71*, 4700–4702. (b) Meyer, A. et al., *Tetrahedron Lett.* **2006**, *47*, 8867–8871)

35

leading to the desired PeNAs glycoclusters. The solid supported oligonucleotidic automated synthesis allows for a rapid and efficient preparation of propargylated PeNAs with control of the number of propargyl residues. Excess of reagents can be used to reach quantitative yields for each cycle with washings to remove them. Click chemistry on solid support is an efficient method for the rapid and efficient multiple labeling with azido carbohydrate derivatives. Finally, the cleavage from the solid support is achieved with concomitant deprotection of the glycosylated PeNAs and was used without further purification. The thymidine residue introduced at the pseudo-3'-end allows for the determination of the quantity of material present in the final solution.

Mannosylated and fucosylated PeNAs bearing 4, 6, 8 and 10 carbohydrate residues were synthesized as potential ligands for concanavalin A (ConA) and *Pseudomonas aeruginosa* lectin (PA-IIL). These two lectins are mannose and fucose binding lectins respectively. ConA is a legume lectin from *Canavalia ensiformis* consisting of a tetramer with four mannose/glucose binding sites and is now considered as a model system for studying protein-carbohydrate interactions. Recently, a series of bacterial lectins have been identified that display micromolar affinities for their ligands. Among them, PA-IIL has been identified in *Pseudomonas aeruginosa*, an opportunistic bacterium that is life threatening for immunosuppressed and cystic fibrosis patients and that displays increasing resistance to antibiotics. PA-IIL is a fucose-binding lectin that has been well characterized for its high affinity for fucose and its interaction with other monosaccharides and oligosaccharides. The lectin is a tetramer and the high avidity provided by multivalent ligands could make these compounds of interest for anti-adhesive therapy against bacterial infection.

Experimental

Preparation of the Building Blocks

Automated synthesis requires orthogonally protected multifunctional scaffolds where each functional group can be activated selectively for reacting with the next entity. Pentaerythritol was selected as a tetrafunctional molecule which can be easily desymmetrized through simple reaction schemes. Mono-protection of pentaerythritol with dimethoxytrityl chloride provided the triol **7** (figure 14). Alkylation of **7** using a large excess of propargyl bromide yielded the *bis*-propargylated alcohol **8** in good yield. Reaction of alcohol **8** with 2-cyanoethyl tetraisopropylphosphorodiamidite activated with diisopropylammonium tetrazolidate provided the expected phosphoramidite **9**. This molecule is presenting a masked alcohol and a phosphoramidite moiety for the DNA-like chain elongation, as well as two propargyl residues for a further conjugation with carbohydrate azide derivatives using a [3+2]-cycloaddition reaction (a) Bouillon, C.; Meyer, A.; Vidal, S.; Jochum, A.; Chevotot, Y.; Cloarec, J.-P.; Praly, J.-P.; Vasseur, J.-J.; Morvan, F. J. Org.

Chem. 2006, 71, 4700–4702. (b) Meyer, A., Bouillon, C., Vidal, S., Vasseur, J. J., and Morvan, F. Tetrahedron Lett. 2006 47, 8867–8871).

The synthesis of azido-carbohydrates is required for their conjugation by click chemistry on the propargyl residues. The control of the anomeric configuration of sugars is often crucial for optimal and selective binding to lectins. The *O*-acyl or Fischer stereoselective glycosylation methods were selected for the preparation of the α -D-mannoside or α -L-fucoside derivatives respectively (figure 23).

Glycosylation of mannose peracetate with chlorotriethylenglycol under Lewis acid activation afforded the chlorinated 1,2-*trans* mannoside **36**. Subsequent azidation of the chloroglycol moiety provided the corresponding α -D-mannoside derivative **37**. Glycosylation of L-fucose under Fischer conditions afforded a mixture of anomers (α/β 3/1) which was directly peracetylated to obtain L-fucoside **38**. The separation of each anomer was unsuccessful at that point. Subsequent azidation of **6** afforded the corresponding azide derivative **39** with the same α/β distribution, each anomer was isolated pure after a flash silica gel column chromatography.

Solid-supported Synthesis of PeNAs

The dialkyne phosphoramidite building block **9** was coupled starting from a commercial solid-supported thymidine applying a phosphoramidite elongation cycle on a DNA synthesizer. The thymidine present at the pseudo-3'-end of the polyglycosyl nucleic acid was used as a UV tag for HPLC analyses, as well as for the determination of concentrations in material in solution. The thymidine functionalized beads were subjected to a standard sequence of detritylation, phosphoramidite coupling under benzylthiotetrazole activation, oxidation and capping (figure 24) used for the synthesis of oligonucleotides. This cycle was repeated 2, 3, 4 and 5 times to obtain the oligoalkyne nucleic acid **40a-d** respectively. After elongation, 1,3-dipolar cycloaddition was achieved on solid support using either the α -D-mannoside azide derivative **37** or the α -L-fucoside azide derivative **39** to obtain the fully protected glycosylated PeNAs **41a-d** or **42a-d** respectively. Aminolysis of the protecting groups (i.e. acetates and cyanoethyls) and concomitant cleavage from the solid support using concentrated aqueous ammonia afforded the fully deprotected glycosylated PeNAs **43a-d** and **44a-d** in solution with high purity and good yield. Each glycocluster was analyzed by HPLC and characterized by MALDI-ToF mass spectrometry (see supporting information). The quantities of available materials in solution were determined by UV measurements at 260 nm based on the extinction coefficient of thymidine.

1-Chloro-3,6-dioxaoct-8-yl **2,3,4,6-tetra-O-acetyl- α -D-mannopyranoside (36)**. A solution of 2-[2-(2-chloroethoxy)ethoxy]ethanol (3.66 mL, 25.2

mmol) and peracetylated D-mannose (6.56 g, 16.8 mmol) in anhydrous CH_2Cl_2 (50 mL) was cooled at 0°C before dropwise addition of $\text{BF}_3 \cdot \text{Et}_2\text{O}$ (10.6 mL, 84 mmol). The reaction mixture was stirred at rt for 24 h then poured into saturated aqueous NaHCO_3 (300 mL). The aqueous layer was extracted with CH_2Cl_2 (2×200 mL). The organic layers were combined, dried (Na_2SO_4), filtered and evaporated. The oily residue was purified by flash silica gel column chromatography (PE then PE/EtOAc 3:2) to afford **36** (3.14 g, 37%) as a pale yellow oil. ^1H NMR (CDCl_3 , 300 MHz): δ 1.96, 2.01, 2.08, 2.13 (4s, $4 \times 3\text{H}$, $4 \times \text{CH}_3\text{CO}$), 3.58–3.82 (m, 12H, $\text{OCH}_2\text{CH}_2\text{OCH}_2\text{CH}_2\text{OCH}_2\text{CH}_2\text{Cl}$), 4.00–4.13 (m, 2H, H-5, H-6), 4.25 (dd, 1H, $J_{6,5} = 5.1$ Hz, $J_{6,6} = 12.3$ Hz, H-6'), 4.85 (d, 1H, $J_{1,2} = 1.6$ Hz, H-1), 5.22–5.36 (m, 3H, H-2, H-3, H-4). ^{13}C NMR (CDCl_3 , 75 MHz): δ 20.6, 20.7, 20.8, 21.0 (4s, $4 \times \text{CH}_3\text{CO}$), 42.7 (CH_2Cl), 62.3 (C-6), 66.0, 68.3, 69.0, 69.5 (4s, C-2 to C-5), 67.3, 70.0, 70.56, 70.63, 71.3 (5s, $5 \times \text{CH}_2\text{O}$), 97.6 (C-1), 169.6, 169.8, 170.0, 170.6 (4s, $4 \times \text{CH}_3\text{CO}$). $[\alpha]_{\text{D}} = +42$ ($c = 1 / \text{CH}_2\text{Cl}_2$). ESIMS (positive mode) m/z : 521 $[\text{M} + \text{Na}]^+$. HRESIMS (positive mode) m/z : calcd for $\text{C}_{20}\text{H}_{31}\text{Cl}_1\text{O}_{12}\text{Na}_1$ $[\text{M} + \text{Na}]^+$ 521.1402, found 521.1403.

1-Azido-3,6-dioxaoct-8-yl 2,3,4,6-tetra-O-acetyl- α -D-mannopyranoside (37). A solution of **36** (2.9 g, 5.8 mmol), sodium azide (1.89 g, 29.1 mmol) and $n\text{Bu}_4\text{NI}$ (4.3 g, 11.6 mmol) in anhydrous DMF (20 mL) was stirred at 90°C for 24 h. The solution was cooled to rt then diluted with EtOAc (300 mL). The organic layer was washed with water (3×200 mL), dried (Na_2SO_4), filtered and evaporated. The oily residue was purified by flash silica gel column chromatography (PE then PE/EtOAc 1:1) to afford **37** (2.54 g, 86%) as a pale yellow oil. ^1H NMR (CDCl_3 , 300 MHz): δ 1.96, 2.02, 2.08, 2.13 (4s, $4 \times 3\text{H}$, $4 \times \text{CH}_3\text{CO}$), 3.37 (t, 2H, $J = 5.0$ Hz, CH_2N_3), 3.60–3.72 (m, 9H, $\text{OCH}_2\text{CH}_2\text{O}$), 3.74–3.84 (m, 1H, OCH_2), 4.00–4.15 (m, 2H, H-5, H-6), 4.27 (dd, 1H, $J_{6,5} = 5.1$ Hz, $J_{6,6} = 12.4$ Hz, H-6'), 4.85 (d, 1H, $J_{1,2} = 1.5$ Hz, H-1), 5.20–5.37 (m, 3H, H-2, H-3, H-4). ^{13}C NMR (CDCl_3 , 75 MHz): δ 20.62, 20.63, 20.7, 20.8 (4s, $4 \times \text{CH}_3\text{CO}$), 50.6 (CH_2N_3), 62.3 (C-6), 66.0, 68.3, 69.0, 69.5 (4s, C-2 to C-5), 67.2, 69.97, 70.02, 70.6, 70.7 (5s, $5 \times \text{CH}_2\text{O}$), 97.6 (C-1), 169.6, 169.8, 170.0, 170.6 (4s, $4 \times \text{CH}_3\text{CO}$). $[\alpha]_{\text{D}} = +34$ ($c = 1 / \text{CH}_2\text{Cl}_2$). ESIMS (positive mode) m/z : 528 $[\text{M} + \text{Na}]^+$. HRESIMS (positive mode) m/z : calcd for $\text{C}_{20}\text{H}_{31}\text{N}_3\text{O}_{12}\text{Na}_1$ $[\text{M} + \text{Na}]^+$ 528.1805, found 528.1801.

1-Azido-3,6-dioxapent-8-yl 2,3,4-tri-O-acetyl- α -L-fucopyranoside (39). A solution of L-fucose (1 g, 6.1 mmol) and 2-[2-(2-chloroethoxy)ethoxy]ethanol (3 mL, 20.6 mmol) was stirred at rt for 5 min followed by the dropwise addition of $\text{BF}_3 \cdot \text{Et}_2\text{O}$ (1.54 mL, 12.2 mmol). The reaction mixture was stirred at 100°C for 5 h and the solution turned yellow then dark brown. The crude mixture was then poured into pyridine (35 mL) and acetic anhydride (7 mL) was then added at 0°C . The solution was stirred at rt for 48 h then poured into iced water (100 mL) and the aqueous layer was extracted with EtOAc (150 mL). the organic layer was washed with water (100

mL), saturated aqueous NaHCO₃ (100 mL), dried (Na₂SO₄), filtered, evaporated to dryness and co-evaporated with toluene (4×30 mL). The oily residue was purified by flash silica gel column chromatography (CH₂Cl₂ then CH₂Cl₂/EtOAc 4:1) to afford the intermediate 1-chloro-3,6-dioxapent-8-yl 2,3,4-tri-*O*-acetyl-L-fucopyranoside **38** (718 mg) as a colourless oil and as a α/β (3:1) mixture of anomers. A solution of **38** (718 mg, 1.63 mmol), sodium azide (1.06 g, 16.3 mmol) and *n*-tetrabutylammonium iodide (300 mg, 0.81 mmol) in DMF (20 mL) was stirred at 90°C for 16 h. The solution was diluted with water (100 mL) and the aqueous layer extracted with CH₂Cl₂ (2×150 mL). The organic layers were combined, dried (Na₂SO₄), filtered and evaporated to dryness. The oily residue was purified by flash silica gel column chromatography (Hexane/CHCl₃ then Hexane/CHCl₃/Acetone 2:1:1) to afford **39** (441 mg, 16%) as a pale yellow oil. A first crop of the α anomer (113 mg) was obtained followed by two additional crops of 226 mg and 102 mg of α/β mixture of anomers in 4:1 and 1:1 ratio respectively. ¹H NMR (CDCl₃, 300 MHz): δ 1.13 (d, 3H, $J_{6,5}$ = 6.6 Hz, H-6), 1.98, 2.07, 2.16 (3s, 3×3H, 3×CH₃CO), 3.40 (t, 2H, J = 5.2 Hz, CH₂N₃), 3.60–3.85 (m, 11H, OCH₂, H-5), 4.23 (q, 1H, $J_{5,6}$ = 6.6 Hz, H-5), 5.10–5.17 (m, 2H), 5.30 (dd, 1H, $J_{2,1}$ = 1.1 Hz, $J_{2,3}$ = 3.4 Hz, H-2), 5.34–5.40 (m, 1H).

General procedure for the automated synthesis of propargylated PeNAs (40a-d). The syntheses of propargylated PeNAS **40a-d** were performed on a DNA synthesizer (381A, ABI) on 1 μ molar scale using standard phosphoramidite chemistry with commercial LCAA-CPG solid-supported 5'-*O*-dimethoxytrityl-thymidine (500Å) and phosphoramidite **9**. The pseudo-oligonucleotidic chain elongation cycle was as follows: *Dedimethoxytritylation* was performed with trichloroacetic acid (3% in CH₂Cl₂) for 60 s; *coupling* was performed with **36** (0.09 M in acetonitrile, 18 molar eq) activated with benzylthiotetrazole (0.3 M in acetonitrile) for 60 s; *oxidation* was performed with I₂ (0.1 M in THF/pyridine/water 90:5:5, v/v/v) for 20 s and *capping* was performed successively with a 1:1 solution of Cap A (Ac₂O in pyridine/THF 1:1:8, v/v/v) and Cap B (10% *N*-methyl-imidazole in THF) for 16 s.

General procedure for the synthesis of glycosylated PeNAs (43a-d and 44a-d). Solid-supported propargylated PeNAs **40a-d** were transferred into a microwave vial and azido carbohydrate derivatives **37** or **39** (0.6 M in MeOH, 5 molar eq per alkyne), CuSO₄ (0.1 M in water, 0.2 molar eq per alkyne), sodium ascorbate (0.25 M in water, 1 molar eq per alkyne) were added and the solution was completed with water and MeOH to obtain a final volume of 200 μ L water/MeOH (1/1). The vial was sealed then irradiated with microwaves for 30 min at 60°C to afford **41a-d** or **42a-d** respectively. Treatment of the beads with concentrated aqueous ammonia for 2 h at rt afforded the oligoGNAs **43a-d** or **44a-d** respectively. The concentration of the glycosylated PeNAs was determined by UV measurement at 260 nm based on the extinction coefficient of

thymidine ($\epsilon^{260\text{nm}} = 8700 \text{ L}\cdot\text{mol}^{-1}\cdot\text{cm}^{-1}$) and characterized by MALDI-ToF mass spectrometry (Table 2).

Table 2. Quantities and MALDI-ToF data obtained for PeNAs **43a-d** and **44a-d**.

Glycosylated PeNAs	Quantity obtained (mg)	Number of moles (μmol)	$[\text{M} - \text{H}]^-$ Calcd.	$[\text{M} - \text{H}]^-$ Found
43a	10.32	00.56	2138.99	2138.01
43b	20.22	00.66	3087.99	3087.39
43c	20.52	00.57	4036.74	4036.87
43d	30.18	00.58	4985.62	4985.29
44a	00.88	00.43	2074.99	2075.29
44b	10.89	00.63	2991.87	2992.12
44c	0.43	00.62	3908.75	3908.22
44d	0.77	00.57	4825.63	4825.43

CLAIMS

1- Molecules of formula (XIII):

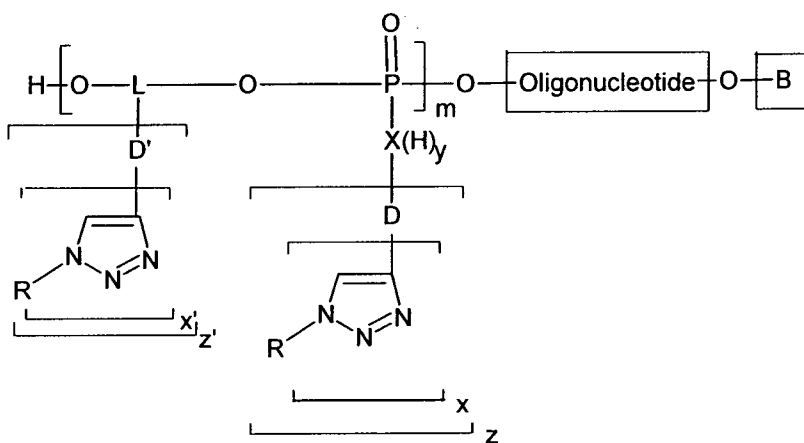

(XIII)

5

wherein

X is selected from N, O, S, an alkane di-yl comprising 1 to 12 carbon atoms; preferentially X is selected from N, O ;

m is an integer, $m \geq 1$

L is a linker which may be selected from the following list: alkane poly-
 10 yl functions with 1 to 12 carbon atoms, linear branched or cyclic possibly interrupted by one or several oxygen (-O-), nitrogen (-NH-, -N=) or sulphur (-S-) bridges or phosphodiester [-O-(O⁻)P(=O)-O-] bridges;

x is an integer, $30 \geq x \geq 1$;

x' is an integer, $30 \geq x' \geq 1$;

15

D is a linker between X and the carbon in position 4 of the triazole ring;

D' is a linker between L and the carbon in position 4 of the triazole ring;

y is 0, 1 or 2;

z and z' are integers, z and $z' \geq 0$, at least one of z and z' is ≥ 1 ;

B is selected from H, a solid support or a tag.

20

the oligonucleotide is substituted either on its 3'-extremity, on its 5'-extremity or inside of the sequence;

R is a molecule of interest.

2- Molecules according to claim 1 of formula (III):

46

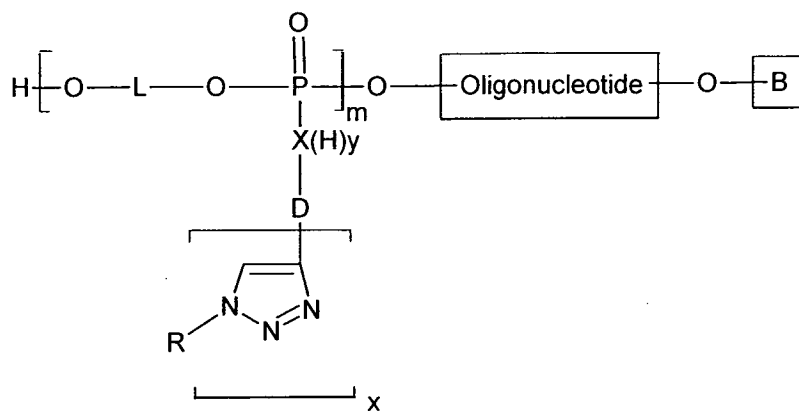

(III)

wherein

X is selected from N, O, S, an alkane di-yl comprising 1 to 12 carbon atoms; preferentially X is selected from N, O ;

5 m is an integer, $m \geq 1$

L is a linker which may be selected from the following list: alkane di-yl functions with 1 to 12 carbon atoms, linear branched or cyclic possibly interrupted by one or several oxygen (-O-), nitrogen (-NH-, -N=) or sulphur (-S-) bridges or phosphodiester [-O-(O⁻)P(=O)-O-] bridges;

10 x is an integer, $30 \geq x \geq 1$;

D is a linker between X and the carbon in position 4 of the triazole ring;

y is 0, 1 or 2;

B is selected from H, a solid support or a tag.

15 the oligonucleotide is substituted either on its 3'-extremity, on its 5'-extremity or inside of the sequence;

R is a molecule of interest.

3. Molecule according to claim 1 or claim 2, wherein R is selected from the group consisting of carbohydrates and their derivatives.

20 4. Molecule according to claim 3, wherein R is selected from the group consisting of mono and polysaccharides grafted on one of their extremities by a -CH₂-(CH₂-O-CH₂)_r-CH₂- groups, with r an integer, $r \geq 1$.

5. Molecule according to claim 1 or claim 2, wherein R is selected from the group consisting of amino acids and peptides.

25 6. Molecule according to claim 1 or claim 2, wherein R is selected from the group consisting of fluorescent tags.

7. Molecule according to anyone of claim 1 to 6, wherein D is selected from alkane poly-yl groups comprising 1 to 36 carbon atoms, possibly interrupted by one or several oxygen bridges.

8. Molecule according to anyone of claim 1 to 7, wherein L is a linker selected from:

- an alkane poly-yl with 1 to 12 carbon atoms, linear, branched or cyclic;
- a group $\left[\text{CH}_2-\text{CH}_2-\text{O} \right]_t \text{CH}_2-\text{CH}_2-$ with t an integer selected from 1, 2, 3, 4, 5, 6;
- an alkane poly-yl with 1 to 12 carbon atoms including an oxygen comprising heterocycle, like a ribose cycle.

9. Molecule according to anyone of claim 1 to 8, wherein one or several phosphate function(s) of the oligonucleotide chain has been replaced by a phosphoramidate group of the type:

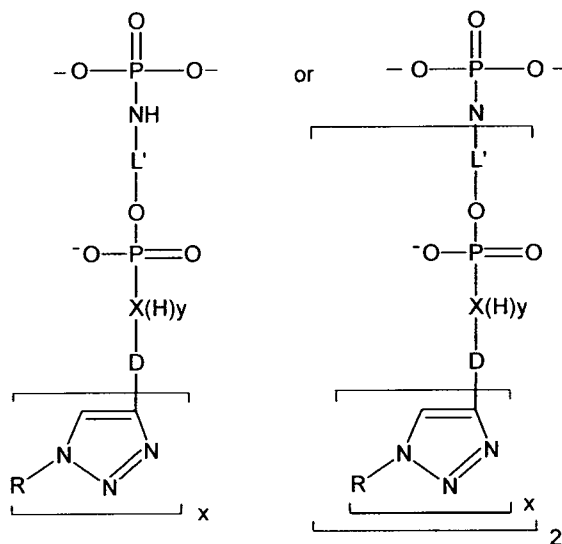

wherein L' is an alkane di-yl chain comprising 1 to 12 carbon atoms.

15

10. Method for the preparation of a molecule according to claim 1 to 9, wherein said method comprises the step of reacting an azido function attached to R with an alkyne substituted phosphodiester derivative of the oligonucleotide:

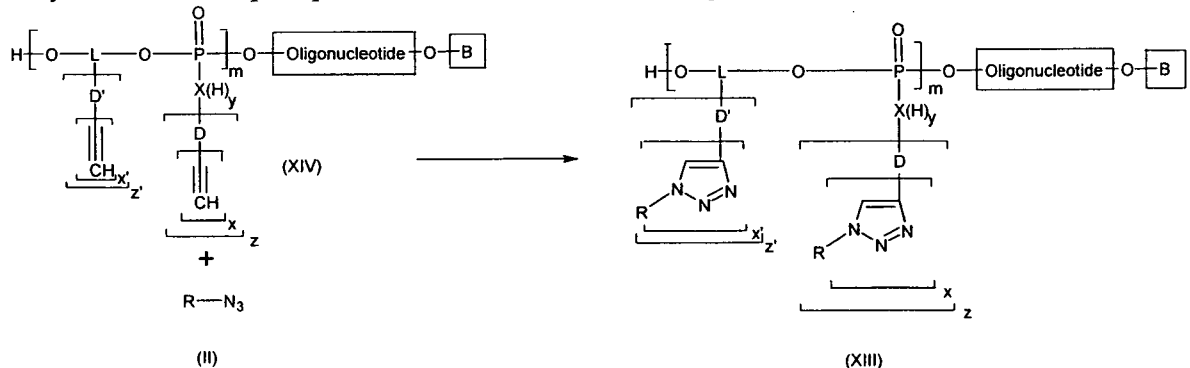

B is selected from H, a solid support or a tag.

19. Molecule according to claim 17 or 18, wherein

D is selected from alkane poly-yl groups comprising 1 to 36 carbon atoms, possibly interrupted by one or several oxygen bridges;

5 m is an integer selected from 1, 2, 3, 4, 5, 6;

L is a linker selected from:

- an alkane poly-yl with 1 to 12 carbon atoms, linear, branched or cyclic;

10 - a group $\left[\text{CH}_2-\text{CH}_2-\text{O} \right]_t \text{CH}_2-\text{CH}_2-$ with t an integer selected from 1, 2, 3, 4, 5, 6;

- an alkane poly-yl with 1 to 12 carbon atoms including an oxygen comprising heterocycle, like a ribose cycle.

20. Method according to claim 10, wherein X=N and the molecule of formula (I) or (XIV) is prepared by a method comprising the following steps: a phosphonate (Va) or a phosphoramidite (Vb) is reacted with an oligonucleotide (IV) on its 3' or 5' extremity or in the sequence, giving a hydrogeno-phosphonate diester (VI), then in a second step compound (VI) is treated by carbon tetrachloride in the presence of an alkyne amine to give the phosphoramidate (XIV) or (I):

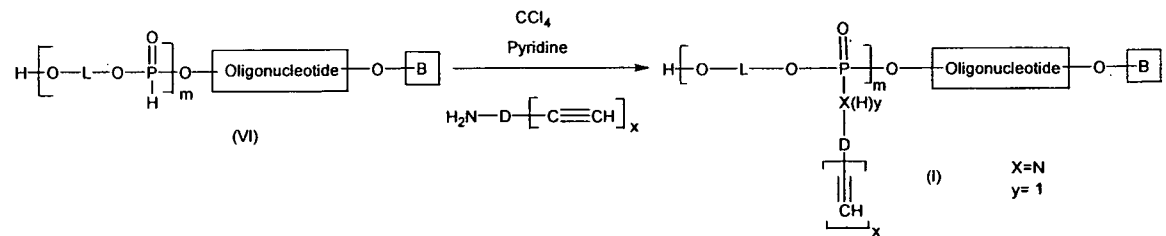
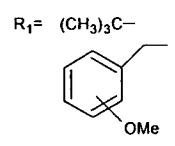
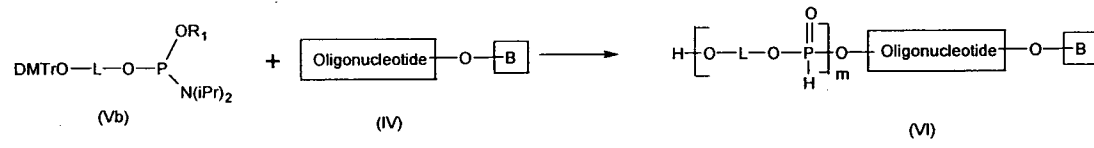

20 21. Method according to claim 10, wherein X=O and the molecule of formula (XIV) or (I) is prepared by a method comprising the following steps: a

phosphoramidite of formula (VII), (VIIa), (VIIb), (VIII), (IX) or (IXa) is reacted with the oligonucleotide (IV) to give directly the molecule (XIV) or (I).

22. Molecule of formula (XV):

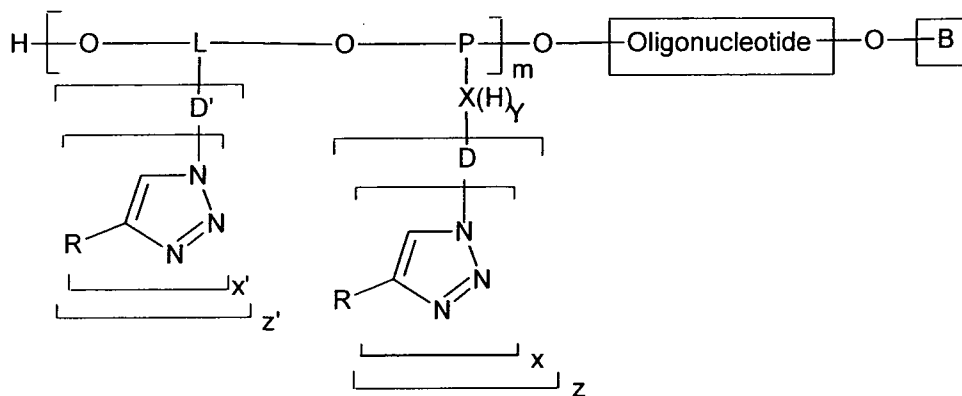

(XV)

5

wherein

X is selected from N, O, S, an alkane di-yl comprising 1 to 12 carbon atoms; preferentially X is selected from N, O ;

m is an integer, $m \geq 1$

10

L is a linker which may be selected from the following list: alkane poly-yl functions with 1 to 12 carbon atoms, linear branched or cyclic possibly interrupted by one or several oxygen (-O-), nitrogen (-NH-, -N=) or sulphur (-S-) bridges or phosphodiester [-O-(O⁻)P(=O)-O-] bridges;

x is an integer, $30 \geq x \geq 1$;

15

x' is an integer, $30 \geq x' \geq 1$;

D is a linker between X and the N atom of the triazole ring;

D' is a linker between L and the N atom of the triazole ring;

y is 0, 1 or 2;

z and z' are integers, z and $z' \geq 0$, at least one of z and z' is ≥ 1 ;

20

B is selected from H, a solid support or a tag.

the oligonucleotide is substituted either on its 3'-extremity, on its 5'-extremity or inside of the sequence;

R is a molecule of interest.

25

23. Molecule according to claim 22 of formula (XII):

52

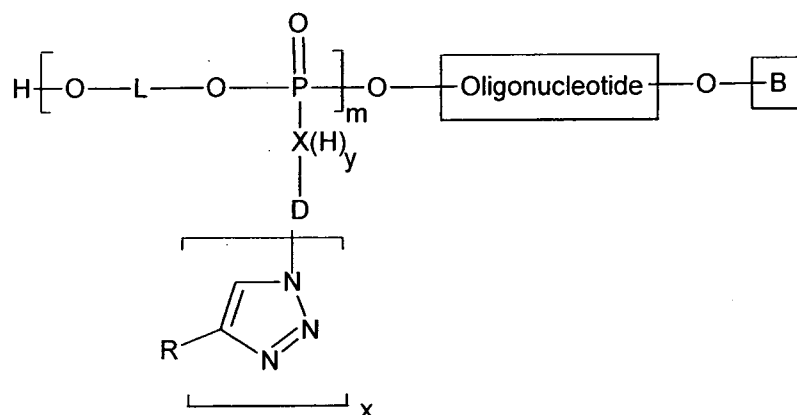

(XII)

wherein

X is selected from N, O, S, an alkane di-yl comprising 1 to 12 carbon atoms; preferentially X is selected from N, O ;

5 m is an integer, $m \geq 1$

L is a linker which may be selected from the following list: alkane di-yl functions with 1 to 12 carbon atoms, linear branched or cyclic possibly interrupted by one or several oxygen (-O-), nitrogen (-NH-, -N=) or sulphur (-S-) bridges or phosphodiester [-O-(O⁻)P(=O)-O-] bridges;

10 x is an integer, $30 \geq x \geq 1$;

D is a linker between X and the N atom of the triazole ring;

y is 0, 1 or 2;

B is selected from H, a solid support or a tag.

15 the oligonucleotide is substituted either on its 3'-extremity, on its 5'-extremity or inside of the sequence;

R is a molecule of interest.

24. Method for the preparation of a molecule of formula (XV) or (XII) according to claim 22 or 23, wherein said method comprises the step of reacting an alkyne function attached to R with an azide substituted phosphodiester derivative of the oligonucleotide as depicted hereunder:

20

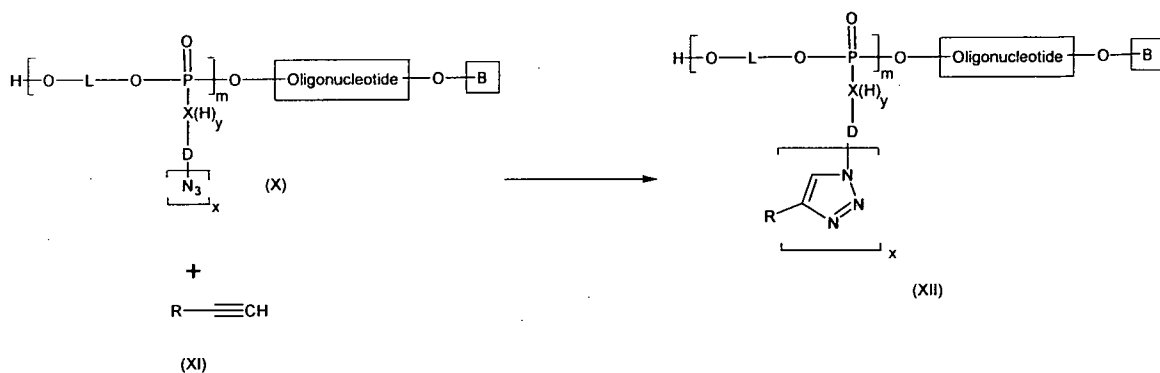

25. Molecules of formula (XVI):

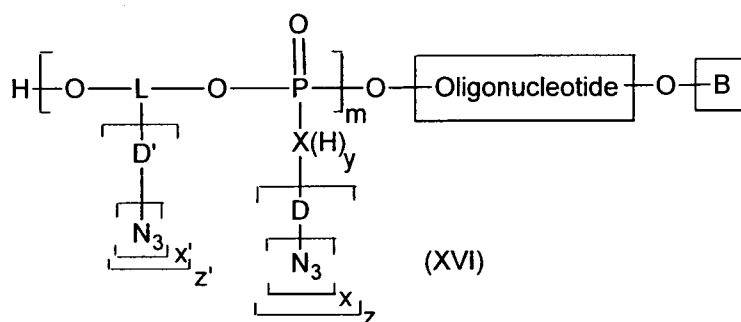

5

wherein

X is selected from N, O, S, an alkane di-yl comprising 1 to 12 carbon atoms; preferentially X is selected from N, O ;

10

m is an integer, $m \geq 1$

L is a linker which may be selected from the following list: alkane poly-yl functions with 1 to 12 carbon atoms, linear branched or cyclic possibly interrupted by one or several oxygen (-O-), nitrogen (-NH-, -N=) or sulphur (-S-) bridges or phosphodiester [-O-(O⁻)P(=O)-O-] bridges;

15

x is an integer, $30 \geq x \geq 1$;

x' is an integer, $30 \geq x' \geq 1$;

D is a linker between X and the azide function;

D' is a linker between L and the azide function;

y is 0, 1 or 2;

20

z and z' are integers, z and z' ≥ 0 , at least one of z and z' is ≥ 1 ;

B is selected from H, a solid support or a tag.

26. Molecule according to claim 25 of formula (X):

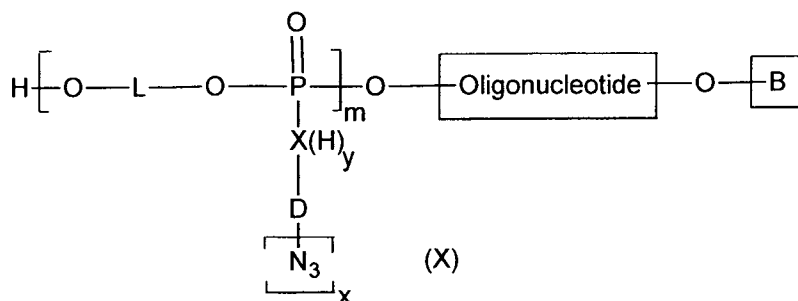

wherein

X is selected from N, O, S, an alkane di-yl comprising 1 to 12 carbon atoms; preferentially X is selected from N, O ;

5 m is an integer, $m \geq 1$

L is a linker which may be selected from the following list: alkane di-yl functions with 1 to 12 carbon atoms, linear branched or cyclic possibly interrupted by one or several oxygen (-O-), nitrogen (-NH-, -N=) or sulphur (-S-) bridges or phosphodiester [-O-(O⁻)P(=O)-O-] bridges;

10 x is an integer, $30 \geq x \geq 1$;

D is a linker between X and the azide function;

y is 0, 1 or 2;

B is selected from H, a solid support or a tag.

15 the oligonucleotide is substituted either on its 3'-extremity, on its 5'-extremity or inside of the sequence.

27. A method for the vectorisation of an oligonucleotide to a biological target in a subject to be treated, wherein a carbohydrate is selected for its specificity for a certain type of cells comprised in the biological target, and said carbohydrate is attached to the oligonucleotide by the method of claim 10 or claim 24 and the resultant molecule (III), (XIII), (XII) or (XV) is administered to the subject to be treated.

28. A solid support grafted by a molecule as depicted in formula (XIII) according to claim 1 or (III) according to claim 2 or a molecule as depicted in formula (XII) according to claim 23 or formula (XV) according to claim 22 in a covalent or non covalent manner.

25 29. A method of investigation of interactions between the R group of the molecules of formula (XIII) or (III) or of formula (XV) or (XII) and a target, especially a biological target, wherein said method comprises the step of contacting a solid support grafted by a molecule responding to formula (XIII) according to claim 1 or (III) according to claim 2 or a molecule as depicted in formula (XII) according to claim 23 or formula (XV) according to claim 22 and the biological target.

30

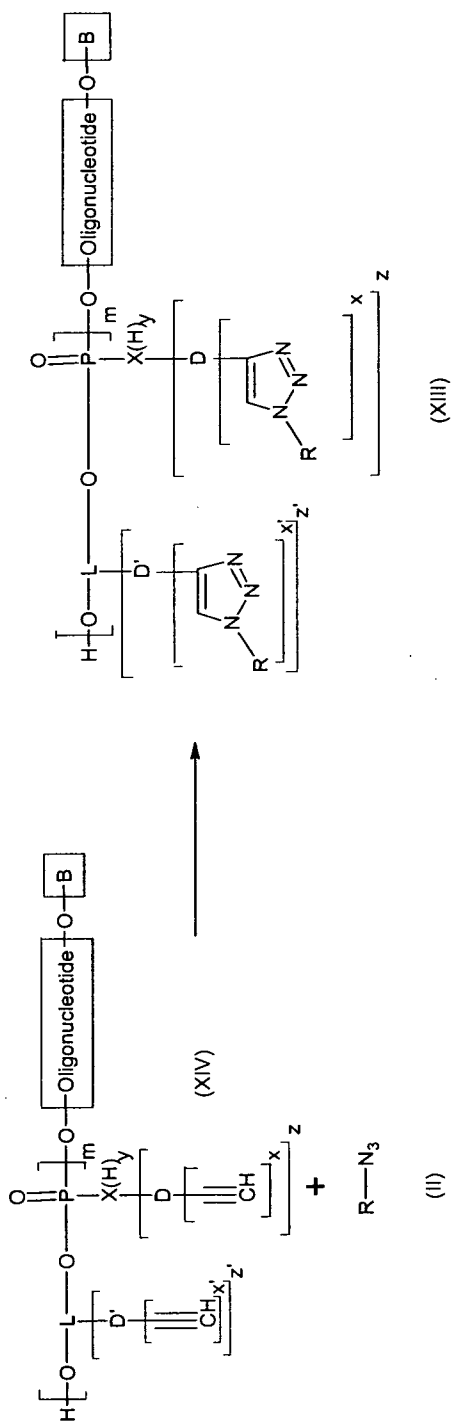

Figure 1B

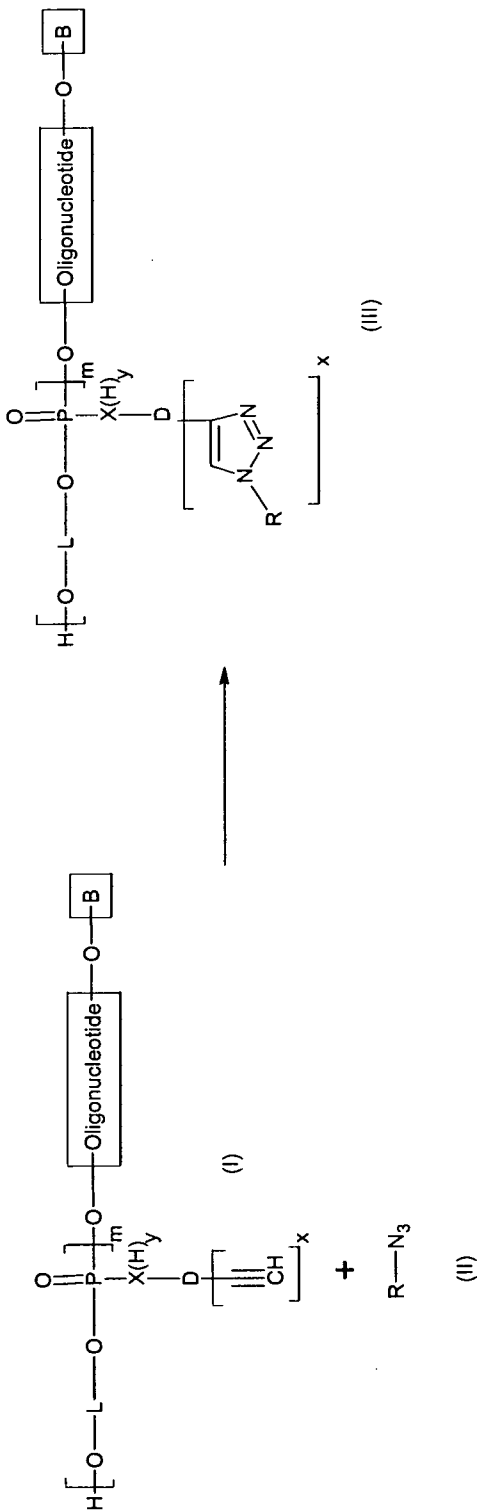

Figure 1A

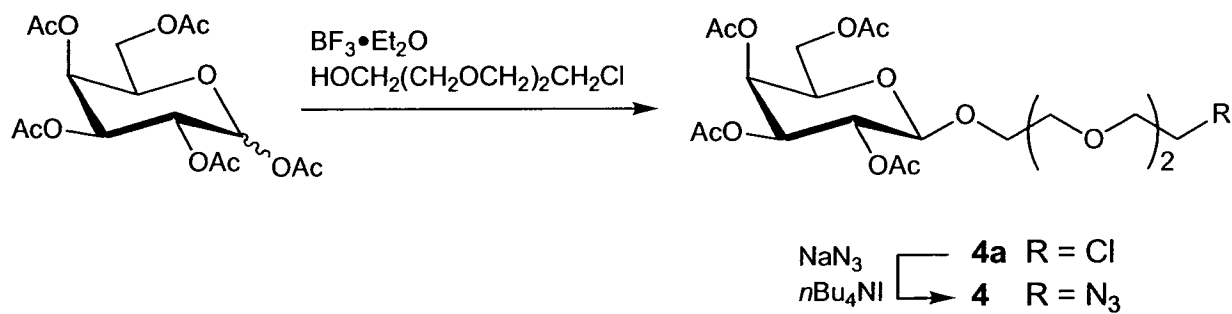

Figure 2

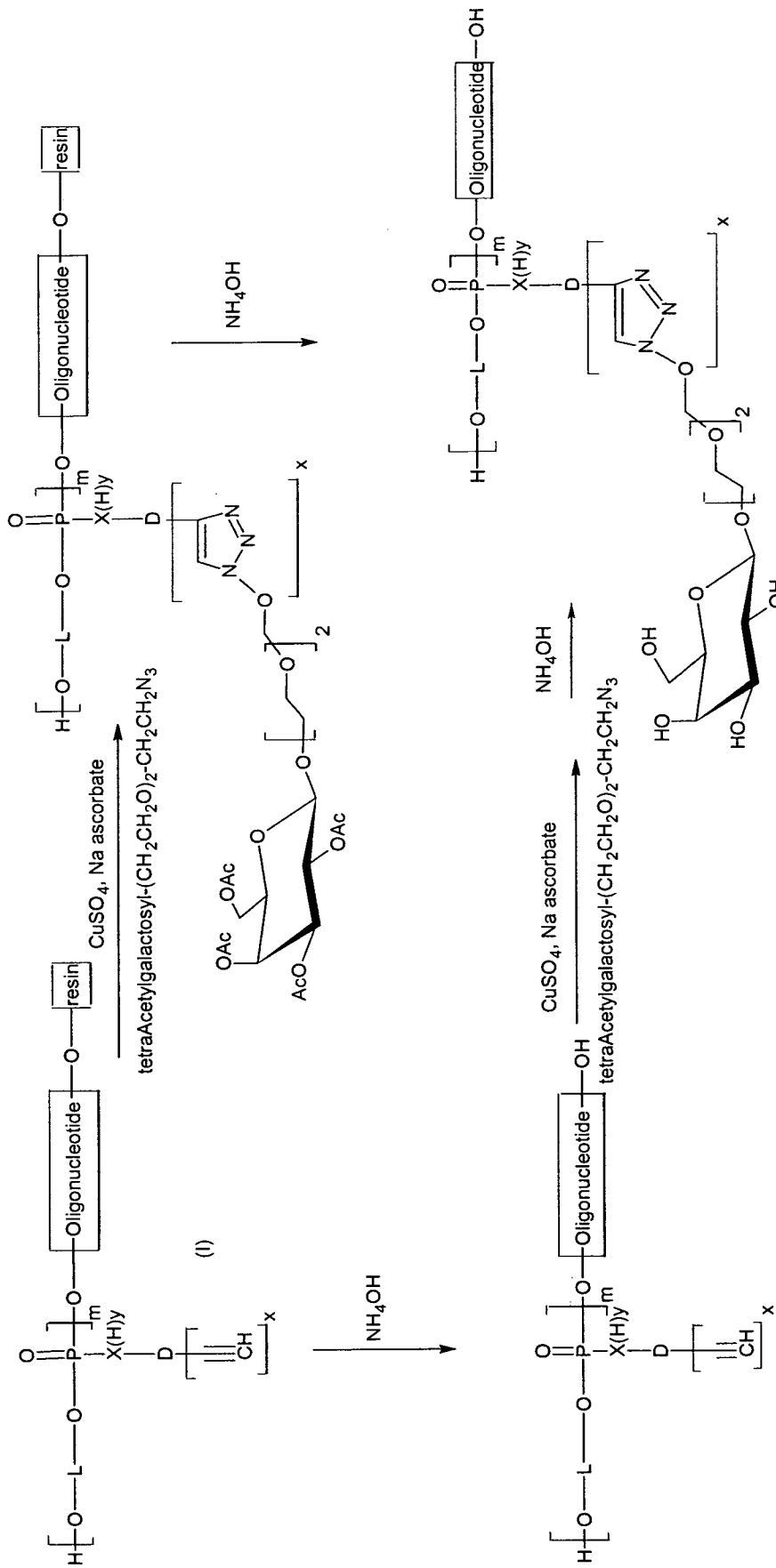

Figure 3

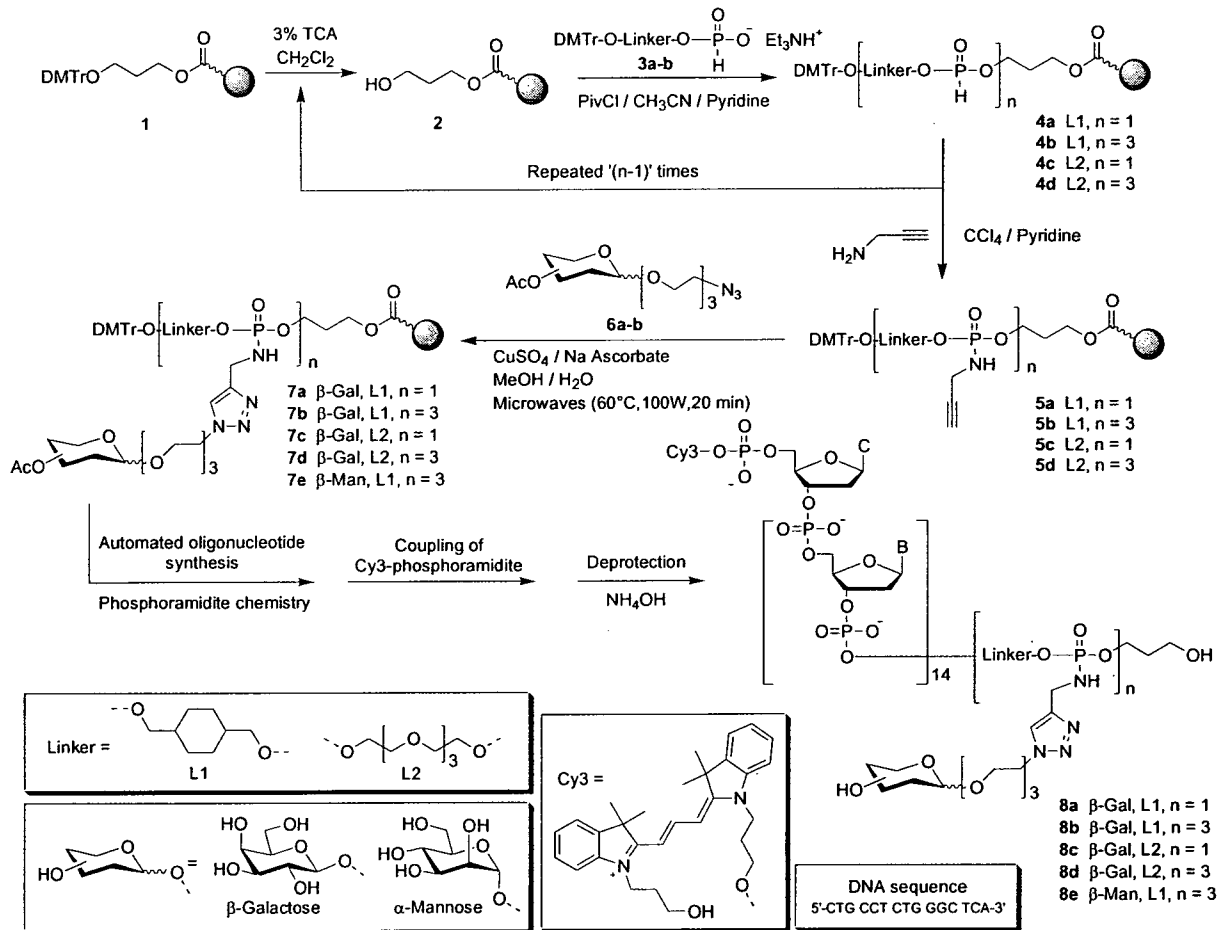

Figure 6

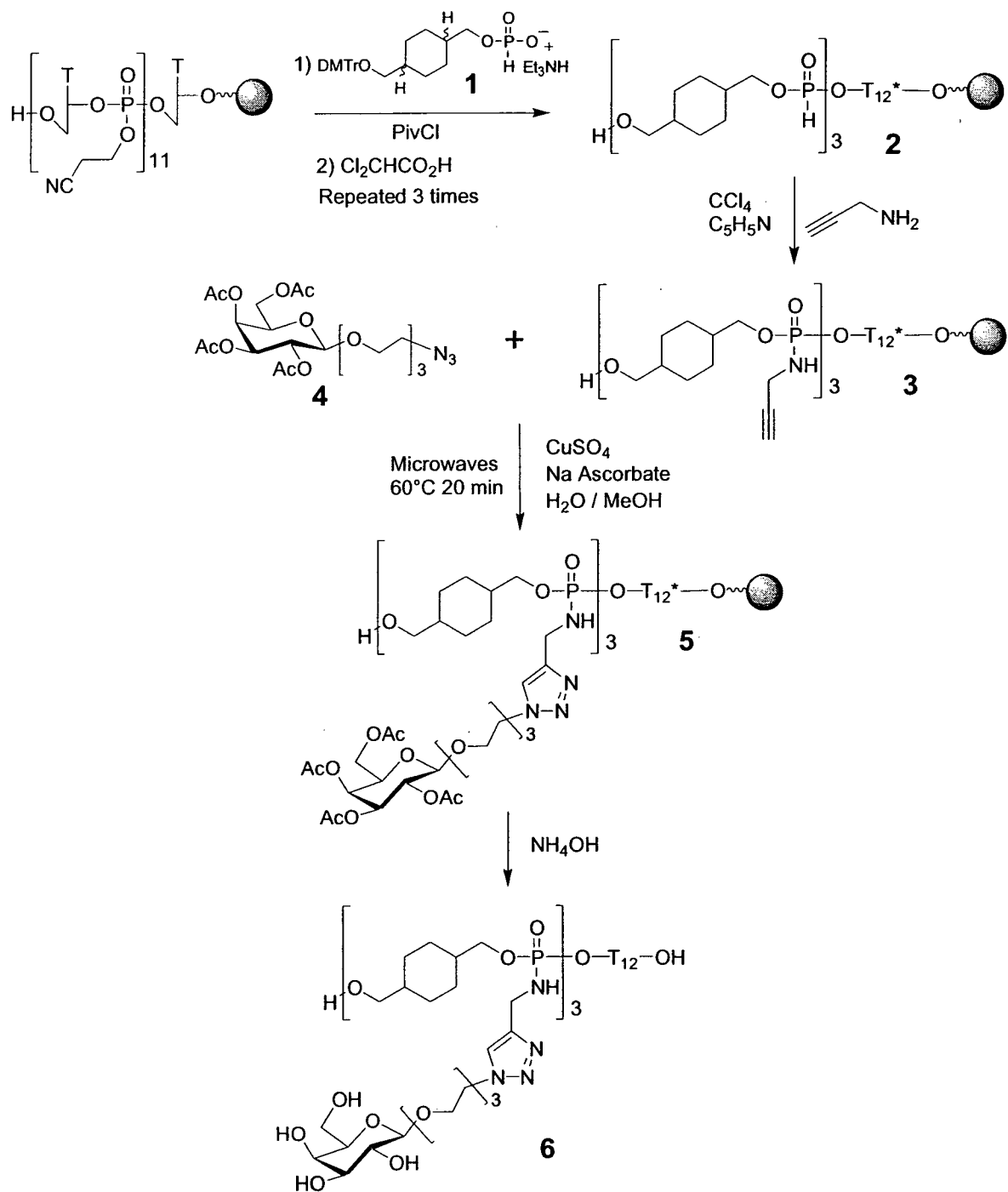

Figure 8 : Solid-supported synthesis of a T_{12} tris-propargyl-phosphoramidate oligonucleotide **3** and its conjugation to galactosyl azide **4** by microwave assisted click chemistry.

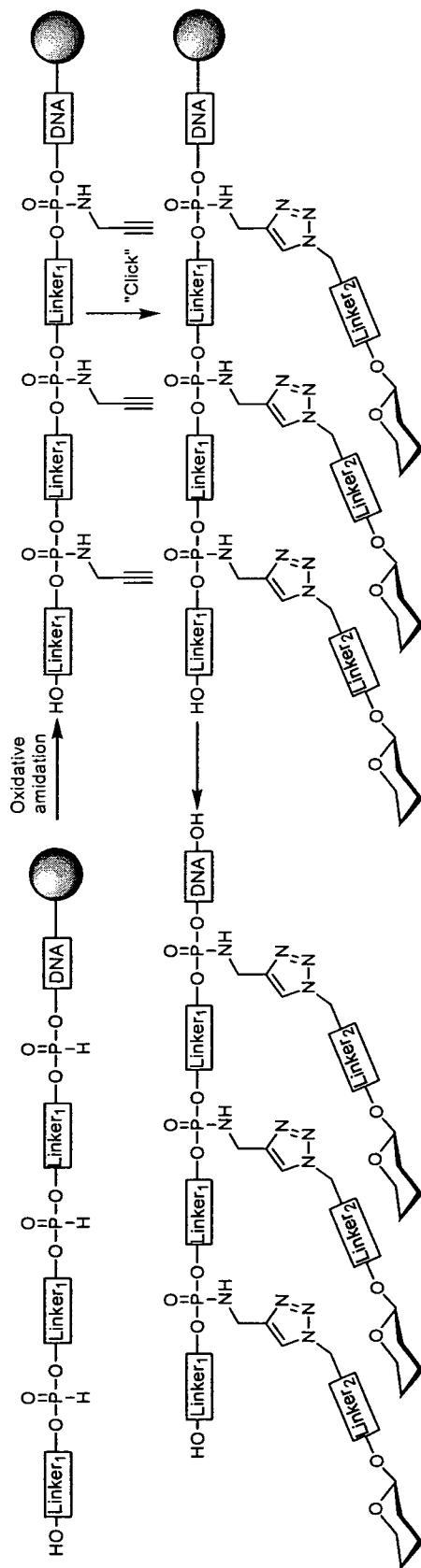
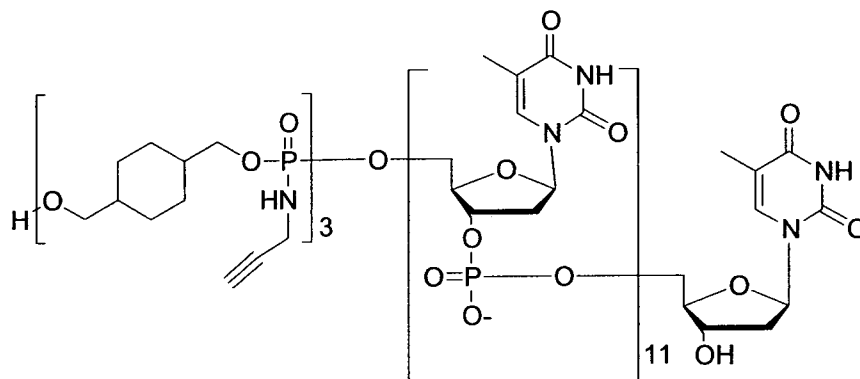

Figure 9



$[M-H]^-$ $m/z = 4317.14$ calculated for $C_{153}H_{210}N_{27}O_{91}P_{14}$

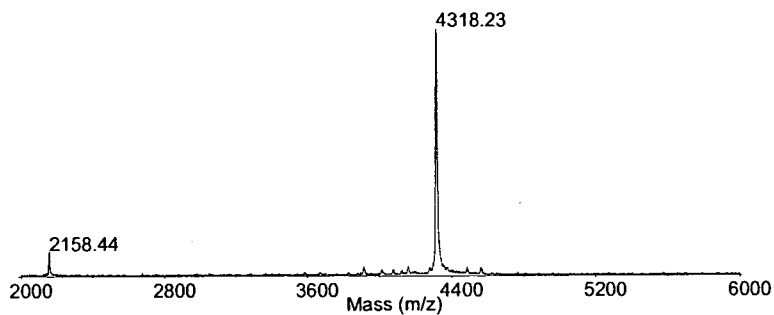
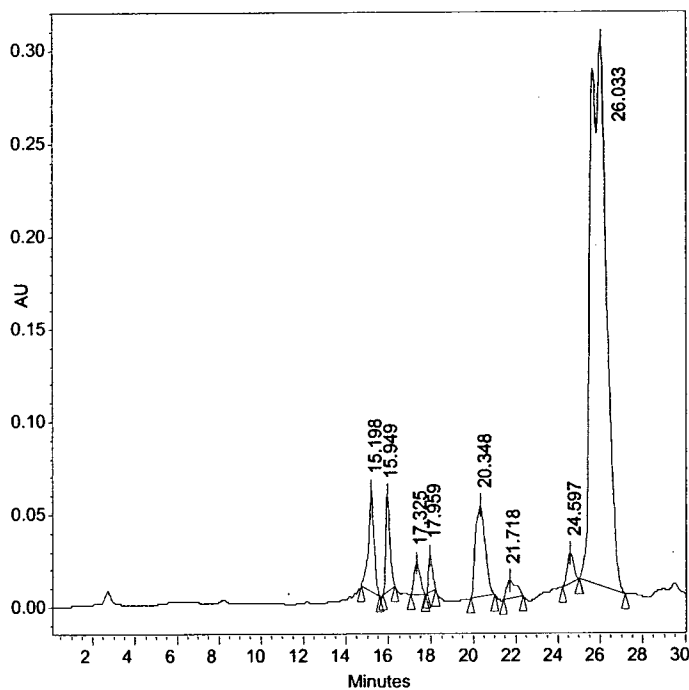
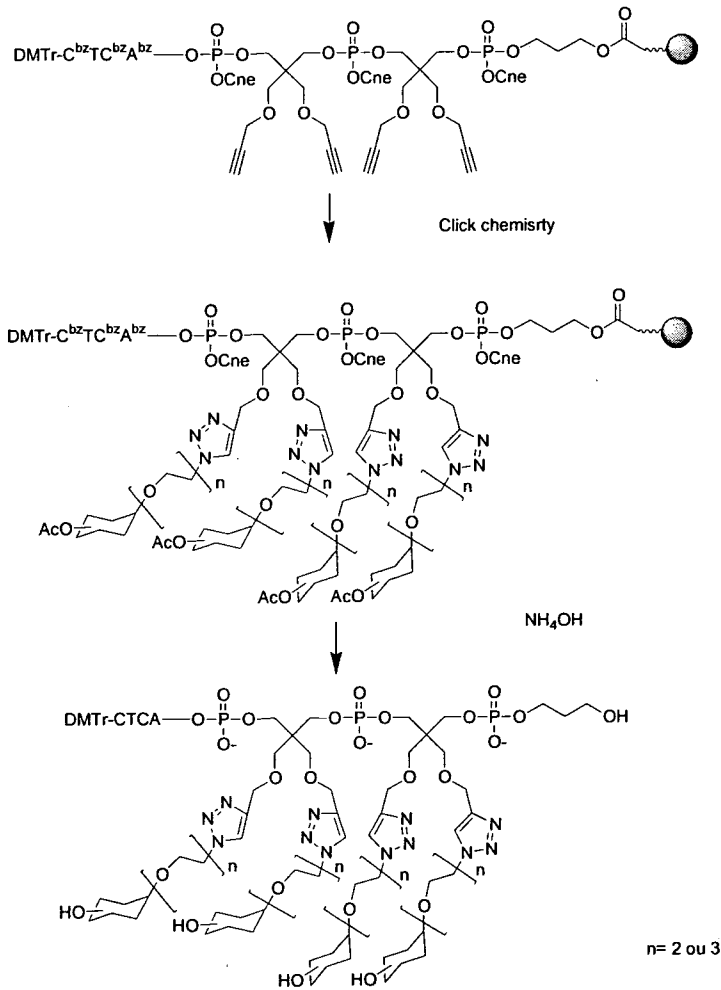

Figure 10

HPLC and MALDI-TOF MS (THAP as matrix) of crude 3 after aqueous ammonia treatment



DMTr = 4,4'-dimethoxytrityl, Cne = cyanoethyl $n=1,2$

Figure 11

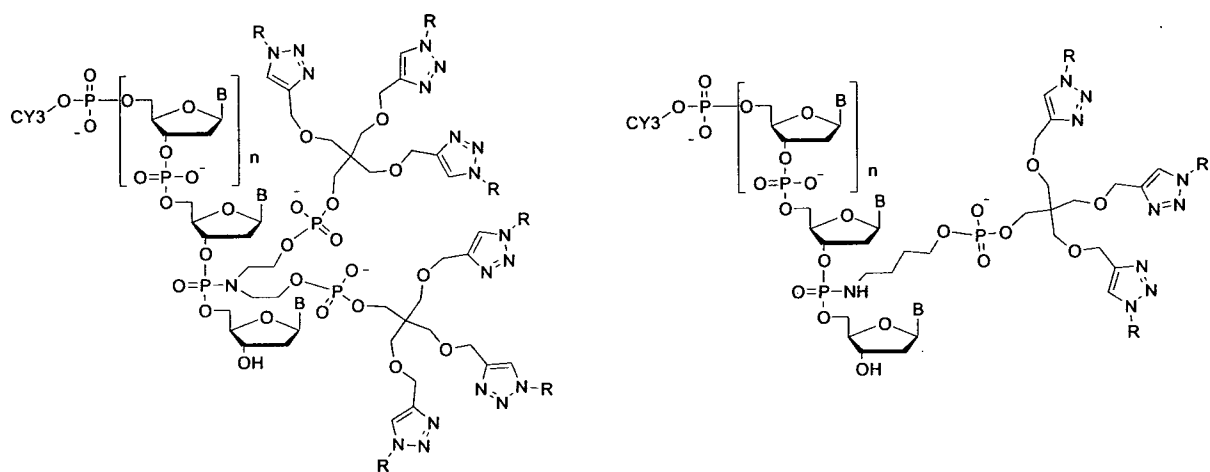

Figure 12

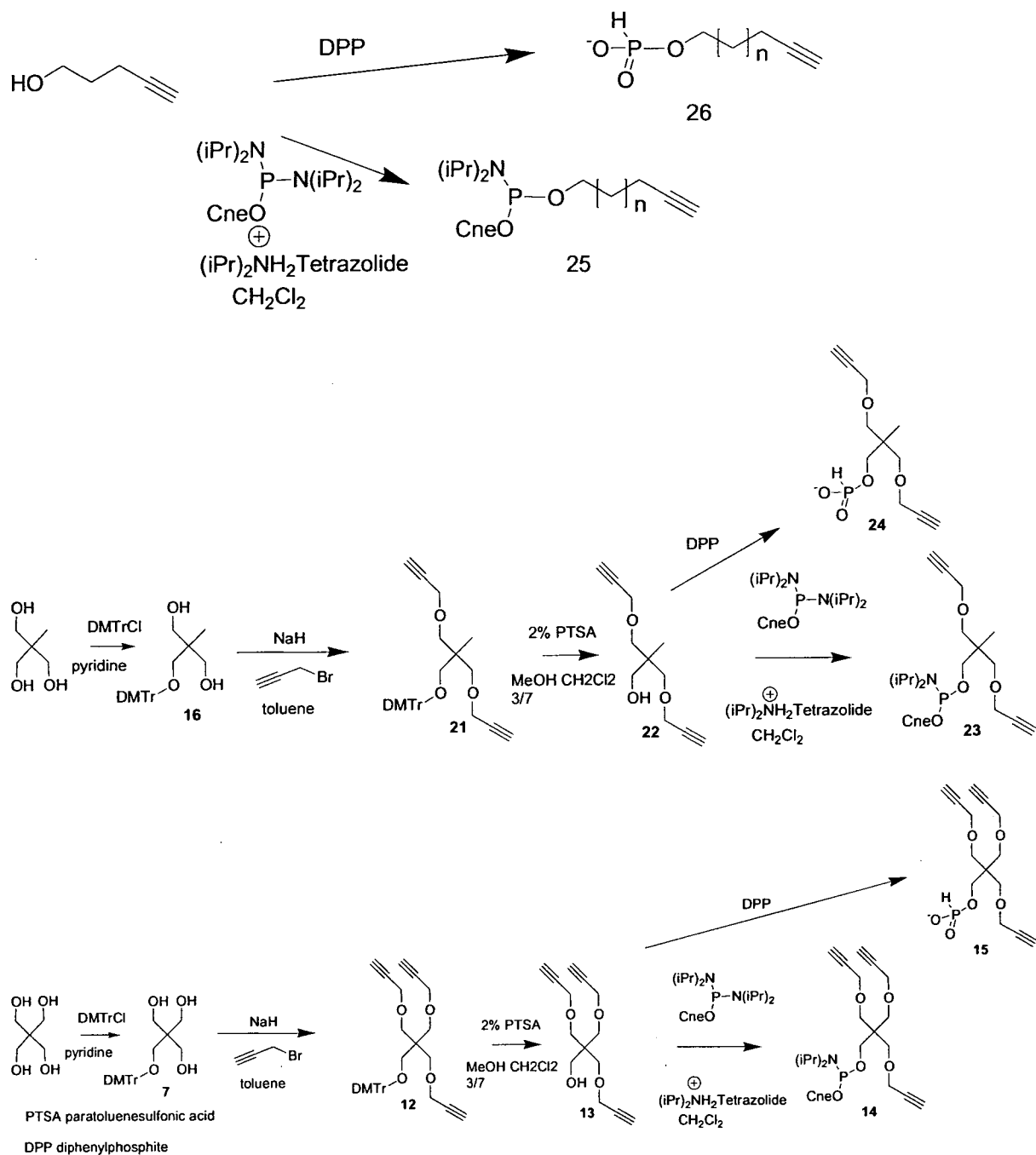

Figure 13: Synthesis of building blocks for introduction of one, two or three alkyne functions in an oligonucleotide.

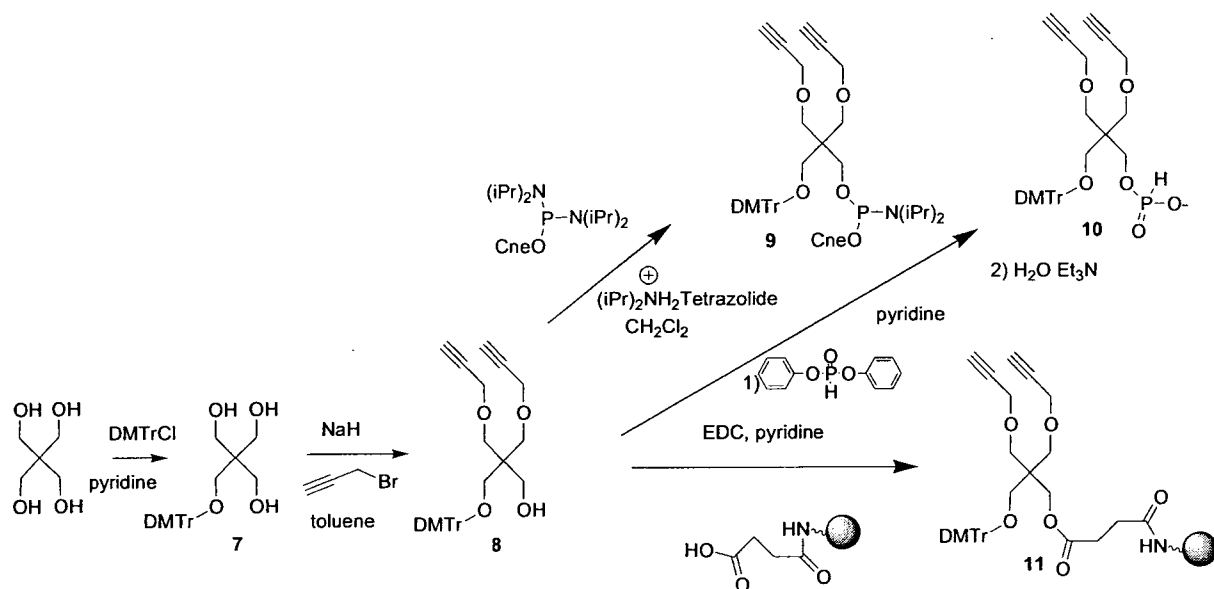

Figure 14: Synthesis of building blocks for introduction of two alkyne functions in an oligonucleotide.

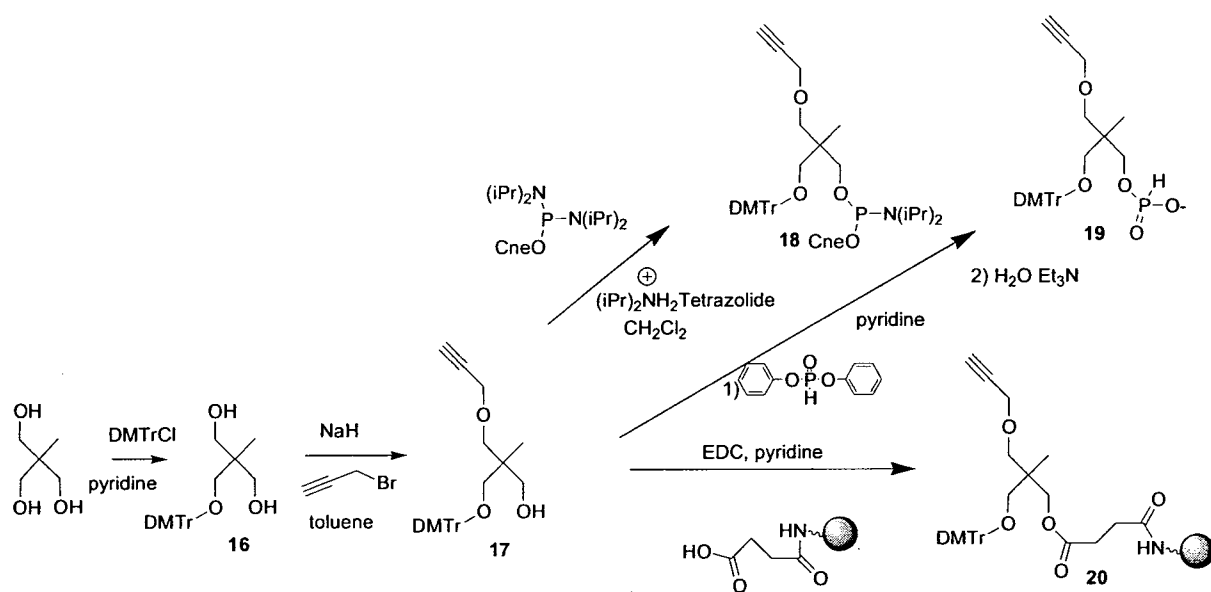

Figure 15: Synthesis of building blocks for introduction of one alkyne function in an oligonucleotide.

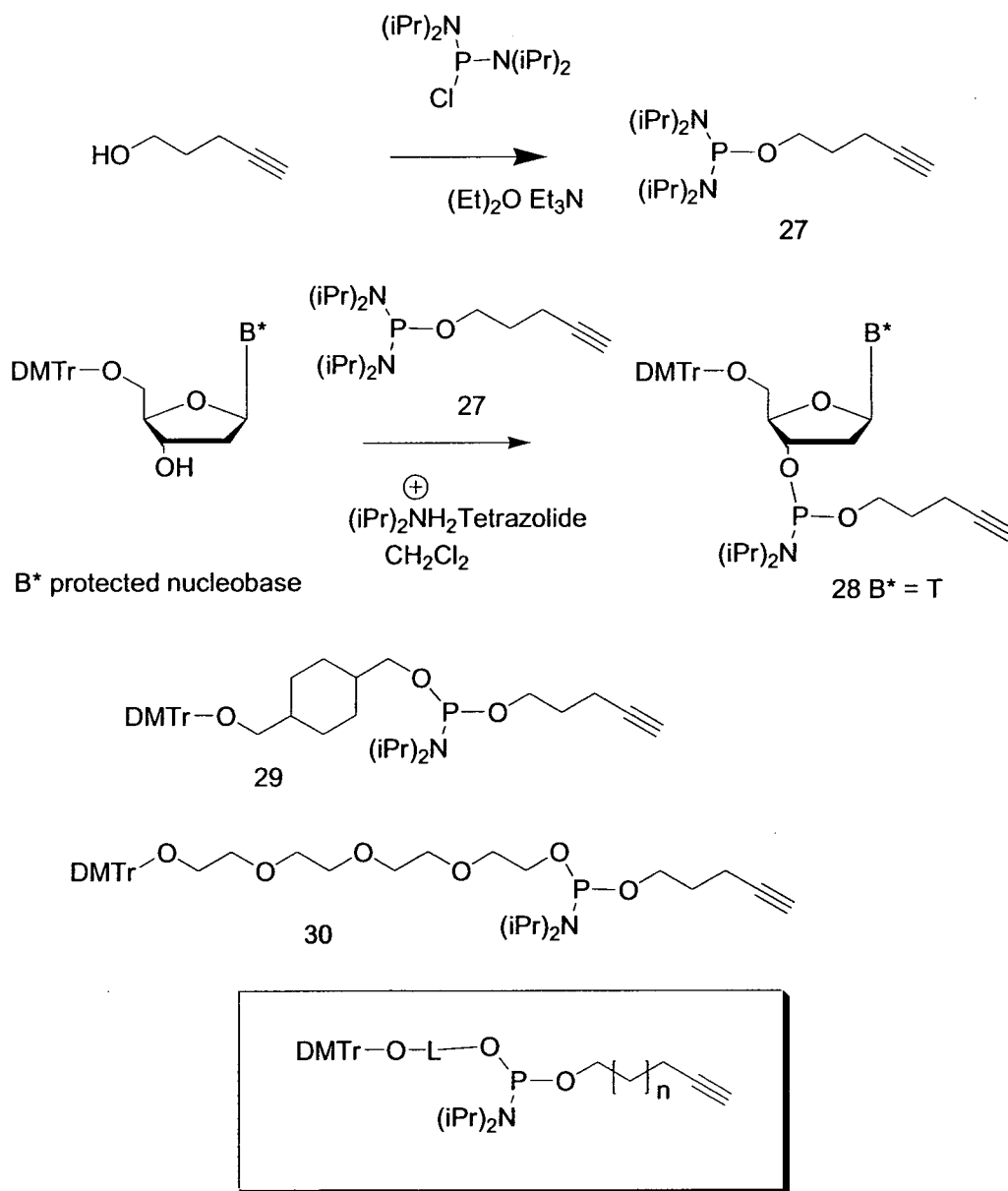

Figure 16: Synthesis of building blocks for introduction of one alkyne function in an oligonucleotide through a phosphotriester linkage.

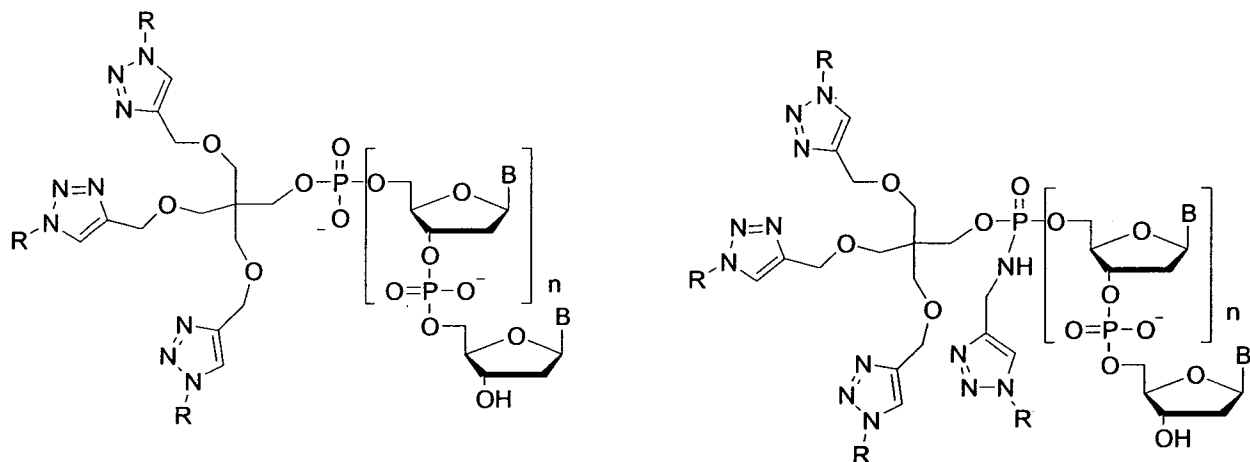

Figure 17: Examples of structures obtained after click chemistry from phosphodiester substituted by three alkyne functions and from a phosphoramidate bearing four alkyne functions

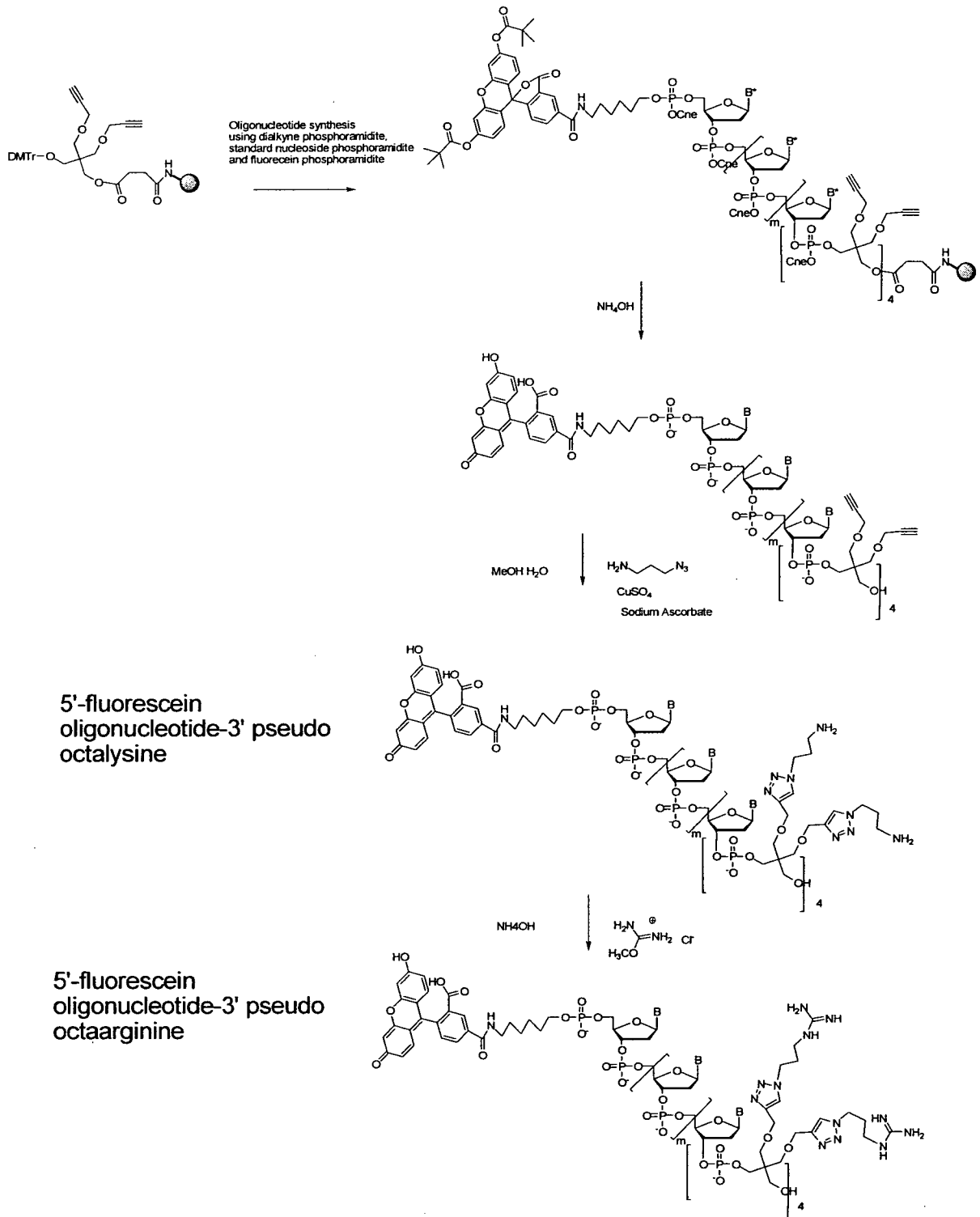

Figure 18

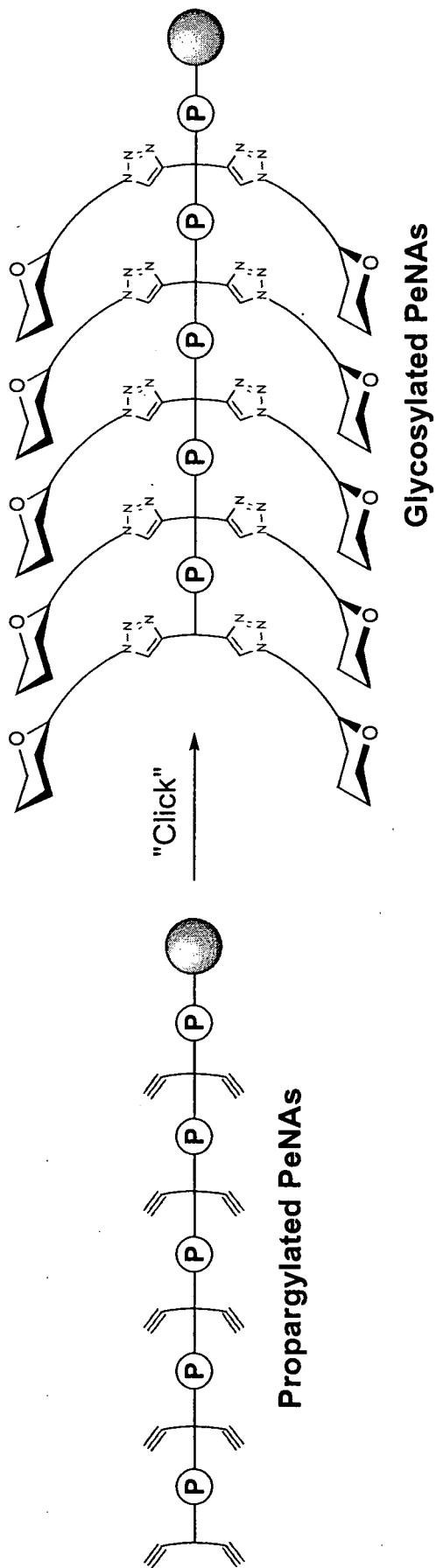

Figure 19

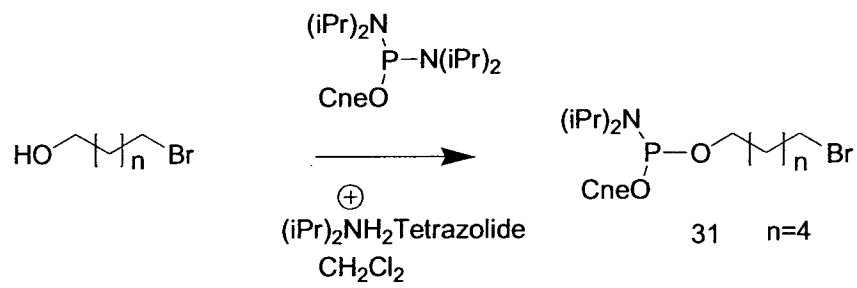

Figure 21

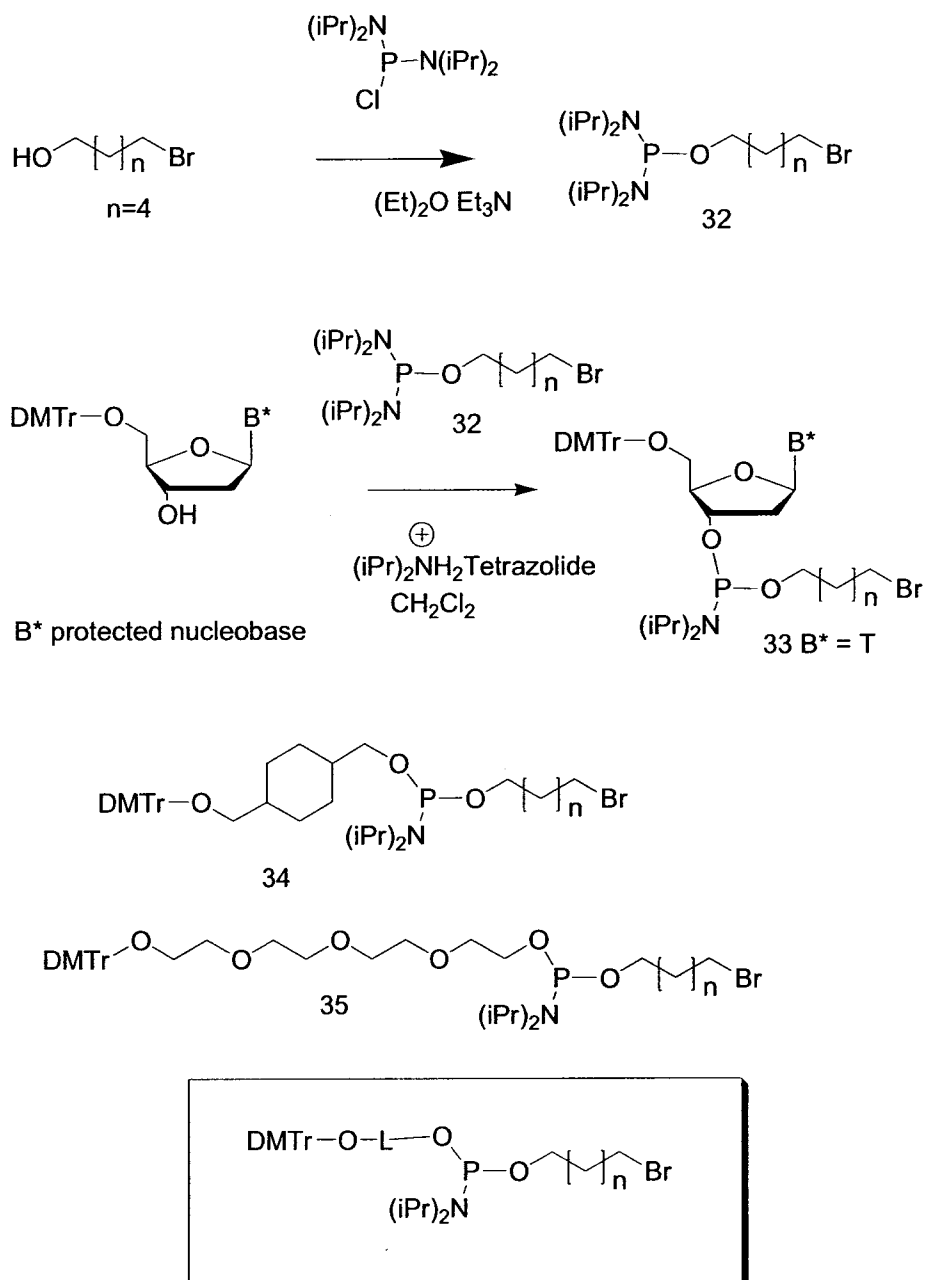

Figure 22

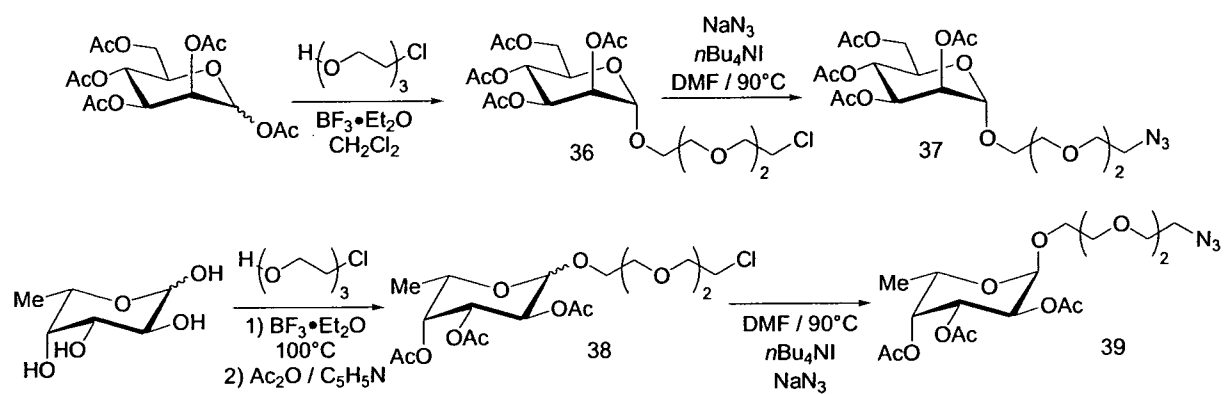

Figure 23

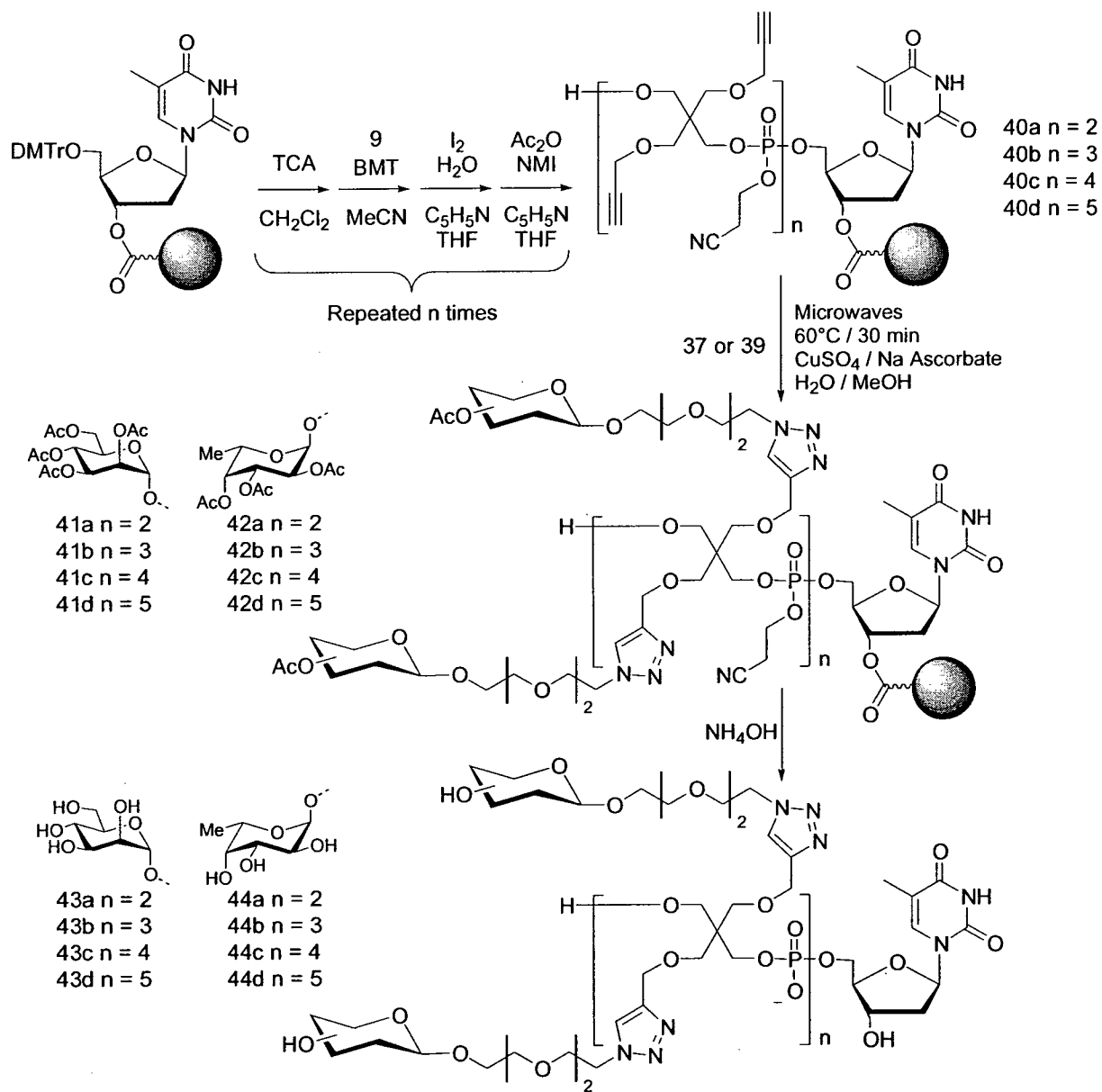

Figure 24