

Oct. 15, 1935.

B. C. ROCKWELL

2,017,185

SLIVER POCKET FLOORING

Filed Aug. 21, 1934

2 Sheets-Sheet 1

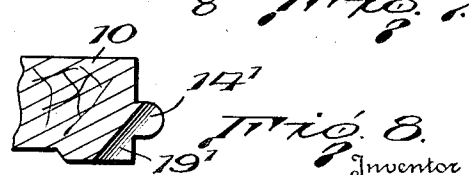
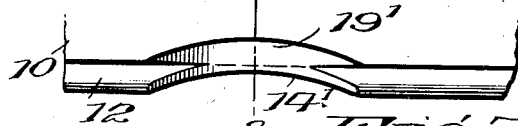
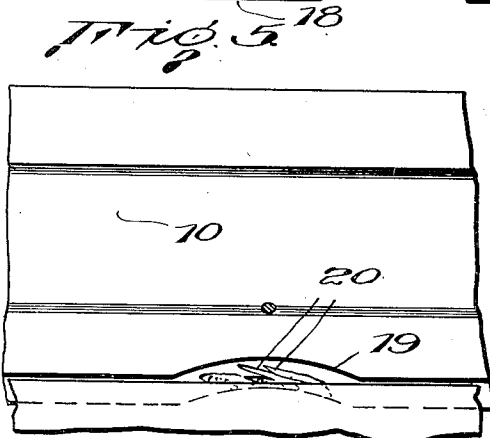
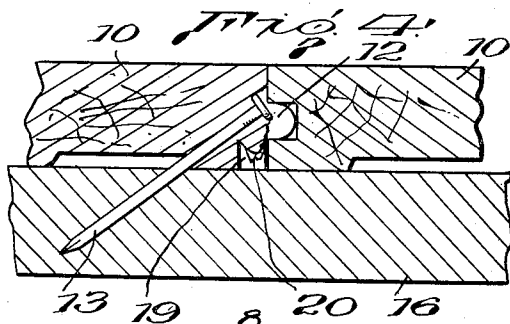
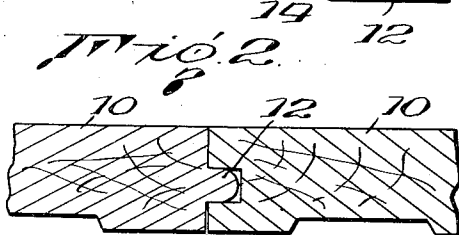
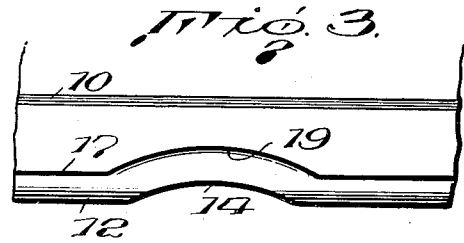
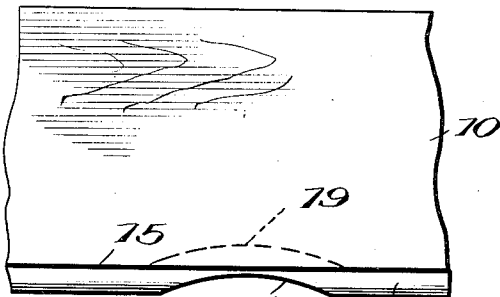
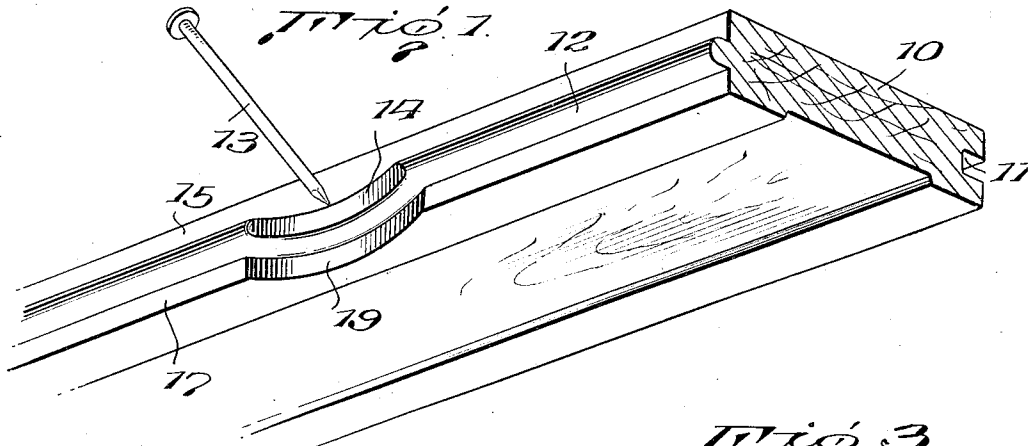

Inventor
Byrd C. Rockwell,

Fig. 6.

By A. R. Townsend Jr.
Attorneys

Oct. 15, 1935.

B. C. ROCKWELL

2,017,185

SLIVER POCKET FLOORING

Filed Aug. 21, 1934

2 Sheets-Sheet 2

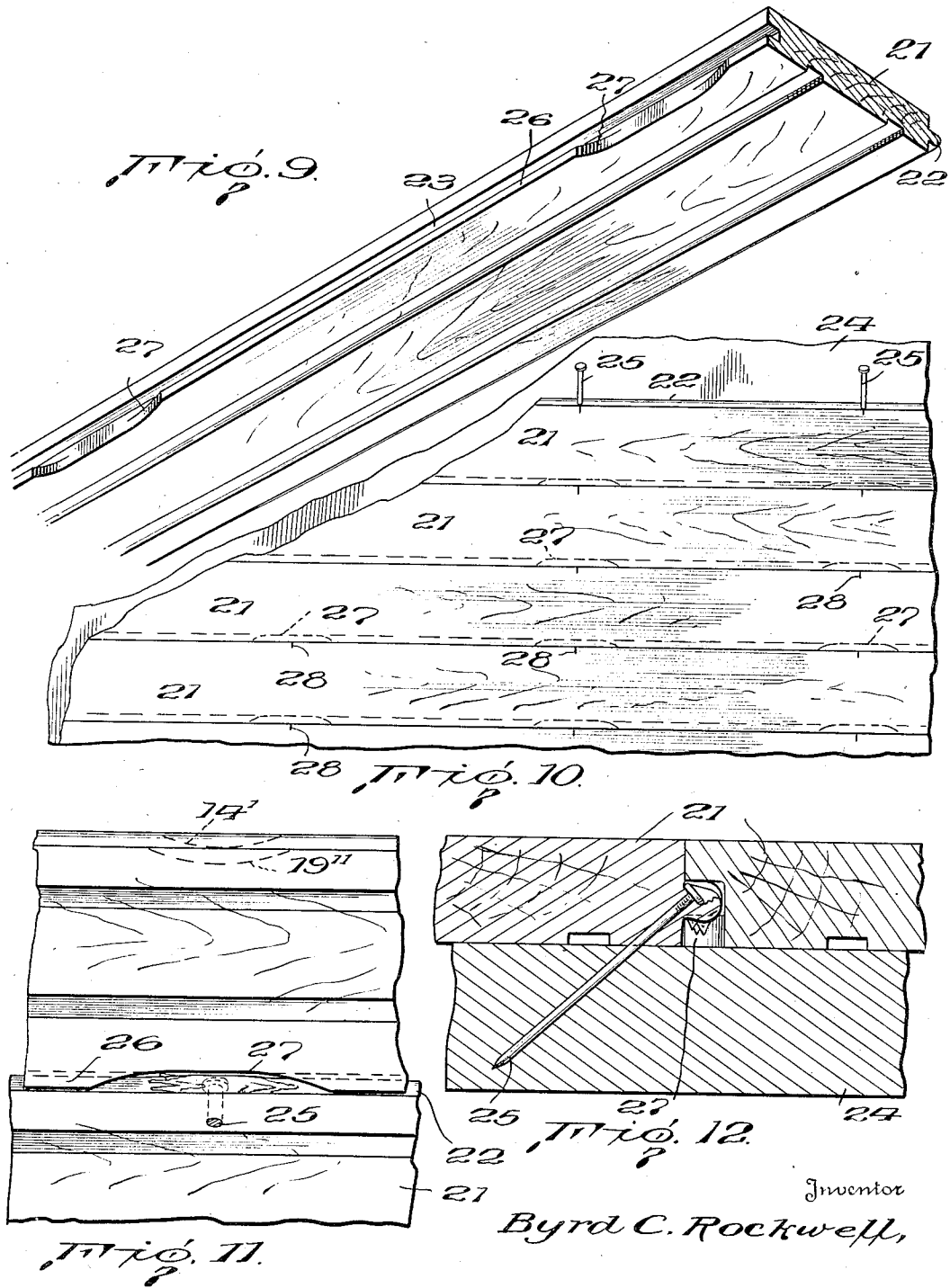

Inventor

Byrd C. Rockwell,

334 A. R. Townsend Jr.
Attorney

UNITED STATES PATENT OFFICE

2,017,185

SLIVER POCKET FLOORING

Byrd C. Rockwell, Sheffield, Ala.

Application August 21, 1934, Serial No. 740,827

18 Claims. (Cl. 20—8)

This invention relates to flooring elements of the standard tongue and groove type, as strip, pattern and block, that are generally installed over subfloors and secured by nails seated at an angle of 45 degrees and driven at the upper inner edge of the tongue at the point of meeting of the tongue and the adjacent edge of the body portion of the flooring element. This practice requires the use of a nail set to countersink the nail head, which increases nailing time. More objectionable than the time increase however, is the battering of the face edge and tongue by the hammer head which mashes, distorts and slivers off the tongue and face edge, damaging the flooring element and preventing proper tongue and groove engagement through the spacing effect of the slivers.

An object of this invention is the provision in a tongue and groove flooring element, of sliver receiving and housing means. Another object is the provision in a tongue and groove flooring element of means for pocketing mashed and slivered material in such manner that it is disposed out of contact with the engaging surfaces of tongue and groove connections, and also, out of contact with the meeting side edge faces of adjacent flooring strips or blocks. Another object is the provision in a tongued flooring element of a sliver receiving recess means formed in the body of the element beneath the tongue.

A further object is the provision of a method of processing tongue and groove flooring lumber to provide preformed sliver receiving pockets adjacent indicated nailing points therein. Other objects will be apparent from the description.

The present application is an improvement upon the invention described in my United States Patent No. 1,936,028 of November 21, 1933. The disclosure of this application constitutes preferred means and method employed in reducing the invention to practice and it is to be understood that such disclosure shall not constitute limitations inconsistent with the scope of the invention as claimed.

In the drawings, Figure 1 is a bottom perspective view of a flooring strip formed in accordance with my invention.

Figure 2 is a fragmentary top plan view thereof.

Figure 3 is a fragmentary bottom plan view thereof.

Figure 4 is a transverse section through a connecting joint of adjacent flooring strips at a nailing point.

Figure 5 is a similar section but taken at a point removed from the nailing point.

Figure 6 is a bottom plan view of a flooring strip joint at a nailing point.

Figure 7 is a fragmentary bottom plan view of an alternative embodiment of flooring strip.

Figure 8 is a section on the line 8—8 of Figure 7.

Figure 9 is a bottom perspective view of a further alternative embodiment of flooring strip.

Figure 10 is a fragmentary plan view of a flooring installation as laid, and embodying the embodiment of flooring strip shown in Figure 9.

Figure 11 is a fragmentary bottom plan view of a flooring strip joint of an installation as shown in Figure 10, at one of the nailing points.

Figure 12 is a transverse section through a connecting joint of a flooring installation as shown in Figures 10 and 11, taken at one of the nailing points.

In all embodiments, the underlying principles of the invention contemplate the provision in a wooden facing element having side edge faces in one of which securing elements are driven in a manner to be concealed by the meeting faces at joints of abutting elements, of pocket recesses provided in the element at a side edge face thereof for accommodating and housing slivers and irregularities of material that is chipped, slivered or distorted by a hammer head in driving home the securing elements.

The sliver pocket means thus provided enables abutting facing elements to be disposed in close contacting engagement at their meeting side edge faces as the spacing effect of slivered and distorted material is eliminated by housing the same within clearance recesses appropriately formed in the elements. As illustrative of a particular facing element the present disclosure deals with flooring of the tongue and groove type.

As shown, a flooring element 10 such as a strip of standard wood flooring has one side face thereof provided with a conventional groove 11 and its opposite side edge face with a tongue 12. At required or suitable nailing distance intervals the tongue is recessed from top to bottom face to indicate seating points for the securing nails, the recesses being of sufficient size and shape to receive therein the driving pole of a carpenter's hammer head. In Figure 1 a securing nail 13 is shown as positioned at a tongue recess 14 just prior to driving home diagonally in the angle between the top face of the tongue and the side edge face 15 of the strip above the tongue. The nail seating and hammer head receiving recesses of

the tongue form the subject matter of my patent hereinbefore noted.

In nailing such flooring to a base or sub-floor 16 a material economy is effected by using flat headed nails, as well as greater holding strength. In driving such nails however, the flat heads sliver the adjacent material, this action being enhanced by the mashing effect of the driving hammer head where it contacts the face of the recess and contiguous face 15 of the flooring element. While the recesses in the tongue insure that the engaging surface of the tongue itself will not be injured by the hammer head, unless relief is provided the slivered material will be forced below the tongue to pile against the side edge face 17 of the flooring element below the tongue.

As shown in Figure 5, in a tongue and groove floor joint the dimensions of groove, face and tongue are such that above the tongue the flat side edge faces of adjacent strips abut in close contact while below the tongue there exists a slight clearance between the faces to allow for tolerance, indicated in Figure 5 as at 18.

This arrangement is standard in tongue and groove flooring. The clearance 18 does not provide any appreciable space and is totally inadequate to receive the slivered material, so that without relief, the slivered material piling beneath the tongue prevents a full engagement of the tongue and groove at a joint, materially enlarging the clearance 18 and thus forcing a distinct and noticeable separation of the meeting joint faces above the tongue, a most undesirable and highly detrimental occurrence.

In the present invention the necessary relief is obtained by cutting away the body of the flooring element beneath the tongue 12 inwardly from the face 17 beneath each nailing point to provide an indented housing or pocket 19 of a size and shape sufficient to receive and house the slivered portions 20. The pocket 19 may be of a size and shape corresponding to its superjacent nail seat recess 14 or larger, or it may take any form desired that provides an indented pocket in the side edge face below the tongue.

It is preferred that the nail seat recesses and silver pocket recesses be cut out at the time the stock is made up so that the finishing flooring element will not require subsequent cutting, having the silver pockets embodied therein at the proper points.

In the alternative embodiment shown in Figures 7 and 8 the strip 10 has its tongue recess 14' undercut diagonally into the body to merge into the silver pocket recess 19'.

The embodiment illustrated in Figures 9 through 12 deals with an adaptation of the invention that is particularly effective where thin flooring is employed, in which the tolerance or clearance between abutting side edge face portions beneath the tongue is negligible and where a tight joint is essential. This thin flooring is standard, and in this embodiment the flooring element or strip, as at 21, has the standard tongue 22 on one side edge face and the groove 23 provided in the opposite side edge face.

As in the case of the thicker flooring it is attached to an under support 24 by securing elements, such as flat headed nails 25 driven diagonally inward from the upper face of the tongue at its meeting angle with the side edge face or adjacent thereto.

In this form of embodiment the lower lip 26 formed by the provision of the groove 23 is cut away from the bottom of the strip and outer edge

of the lip at suitable intervals to provide substantially arcuate recesses or pockets 27 extending laterally inward in the lower lip, the bottoms of the pockets being substantially flush with the bottom of the groove 23. These pockets 27 are of sufficient longitudinal extent and depth to receive and house therein the distorted and slivered portion of the tongue on an adjacent strip at each nailing point, as shown in Figure 12.

To provide accurate registry the strips as processed with the cut outs are provided with suitable indicia means 28 to designate nailing points so that abutting strips may properly be registered therewith as to their sliver pockets. Preferably the indicia means comprises a slight dab of coloring material that is easily removable when an installation is given a finish surfacing.

It is to be understood that if desired, strips may be processed to provide the sliver receiving pockets on both the tongue edge as in Figures 1 through 8 20 and the groove edge as in Figures 9 through 12 as suggested by the dotted line showing of tongue edge recesses 14' and 19' in Figure 11.

I claim:—

1. A flooring element having a tongue, and an indented sliver receiving recess provided in the body of said element adjacent the tongue.

2. A flooring element having a nailing face, and an indented sliver receiving recess cut in the body of said element from nailing points on said nailing face.

3. In a flooring element having a tongue, an indented sliver receiving recess cut in the body of said element directly beneath the tongue.

4. In a flooring element having a tongue, an indented sliver receiving recess in the body of said element below the plane of the tongue.

5. In a flooring element having a tongue provided with nail seat means, an indented sliver pocket disposed in said element below said nail seat means.

6. In a flooring element having a tongue, a nail seating and sliver receiving recess cut through said tongue and into the body of the element beneath the tongue.

7. In a flooring element having a tongue, a nail positioning recess cut in said tongue from its top to its bottom face, and an indented sliver receiving recess cut in said element beneath the tongue in alignment with the nail positioning recess.

8. In a flooring element having a tongue, nail positioning means comprising a recess cut in the tongue, said recess being shaped to provide clearance for a hammer head, and a sliver receiving recess indented in said element below said nail recess.

9. In a flooring element having a tongue, a nail seating recess cut in the tongue and shaped to provide hammer head clearance in the tongue, and a portion of the body of said element being cut out inwardly below said recess to receive slivers.

10. In a flooring element having a tongue on a face thereof, an arcuate recess cut through said tongue with its bottom adjacent the plane of said face whereby to provide a nail seat, and an indented sliver receiving pocket formed in said face beneath said recess.

11. In a flooring element, a tongue on a face thereof and having a portion thereof cut out to form a hammer head clearance recess, the bottom of the recess being spaced laterally slightly from said face to form a ledge, and a sliver re-

ceiving pocket indented in said face beneath said ledge in line with said recess.

5 12. In a tongue and groove flooring element, nail positioning means comprising a recess cut in the tongue, said recess being of a size sufficient to permit the head of a hammer to enter therein without contacting the tongue face, and an indented sliver receiving recess cut in said element in line with the first named recess and extending therebelow.

10 13. In a flooring element having side edges provided respectively with a tongue and a groove, said tongue having a plurality of spaced recesses cut therein to indicate nail seating points and 15 shaped to provide tongue body clearance for the head of a hammer in driving home nails seated at said points, and an indented sliver receiving pocket cut in the body of said element beneath and in alignment with each of said recesses.

20 14. In a tongue and groove flooring joint, indented pockets provided in meeting faces of the joint elements adjacent nailing points to house slivers therein inwardly of the faces.

15. In a wooden facing element having a side edge nailing surface, an indented sliver receiving pocket provided in said surface for housing slivers inwardly thereof.

16. In a wooden facing element having a side edge arranged for interlocking joint connection with another facing element, an indented pocket cut inwardly in the lower portion of said edge and extending to the bottom face of the element.

10 17. In a flooring element having a groove in a side edge thereof, a sliver housing recess provided in said edge and extending inwardly from said edge below the groove.

15 18. In a flooring element having a groove, an indented sliver housing recess cut through the material of said element from its bottom face through the lower wall of the groove, the bottom of the recess being substantially flush with the bottom of the groove.

20 BYRD C. ROCKWELL.