

(No. Model.)

3 Sheets—Sheet 1.

A. P. & E. P. SCARAMANGA.
CIGARETTE MACHINE.

No. 525,060.

Patented Aug. 28, 1894.

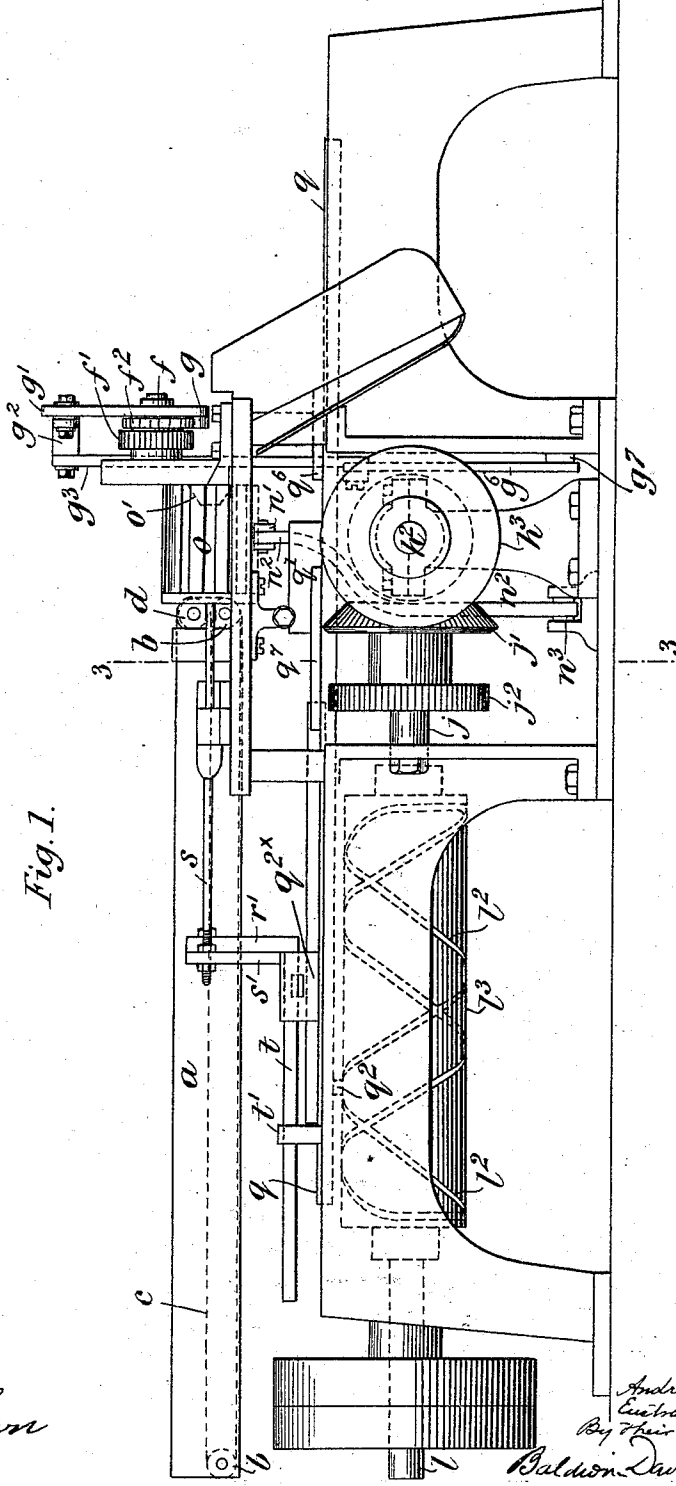

Fig. 1.

Witnesses
B. W. Miller
Charles Brown

Inventors
Andrew P. Scaramanga,
Eustachio P. Scaramanga,
By their Attorneys
Baldwin, Davidson, & Light.

(No Model.)

3 Sheets—Sheet 2.

A. P. & E. P. SCARAMANGA.
CIGARETTE MACHINE.

No. 525,060.

Patented Aug. 28, 1894.

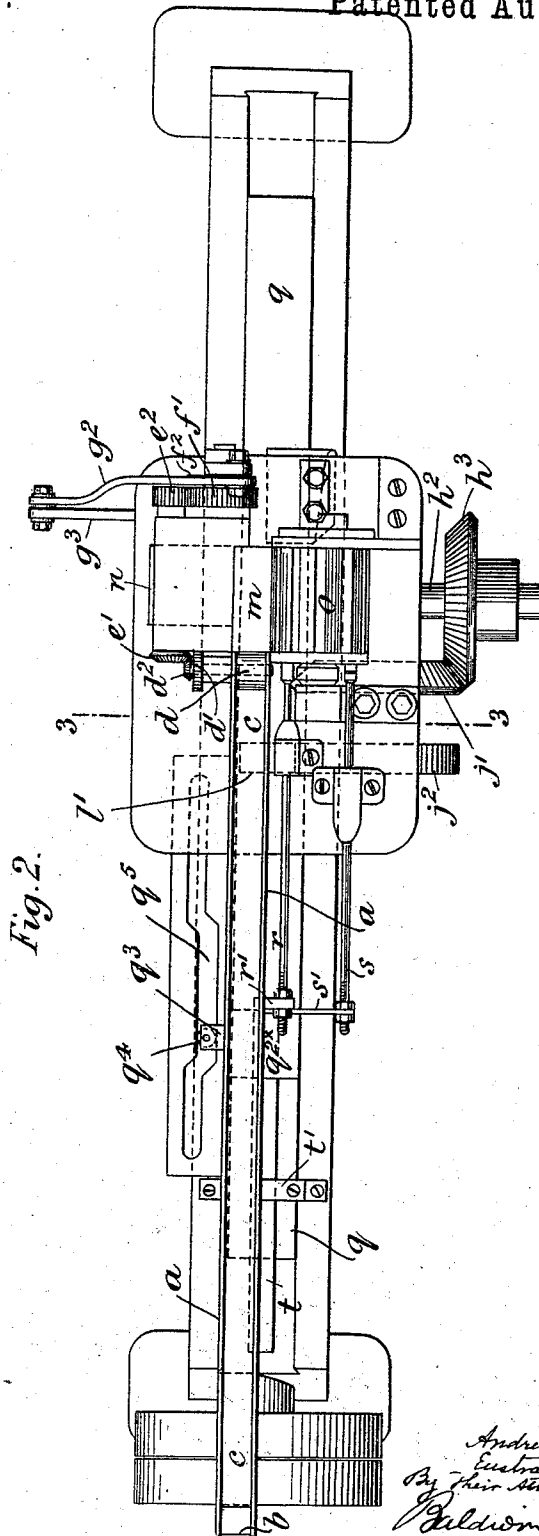

Fig. 2.

Witnesses
C. W. Miller
Sylvester Brown

Inventors
Andrew P. Scaramanga,
Eustachio P. Scaramanga,
By their Attorneys,
Paldwin, Davidson & Night.

(No Model.)

3 Sheets—Sheet 3.

A. P. & E. P. SCARAMANGA.
CIGARETTE MACHINE.

No. 525,060.

Patented Aug. 28, 1894.

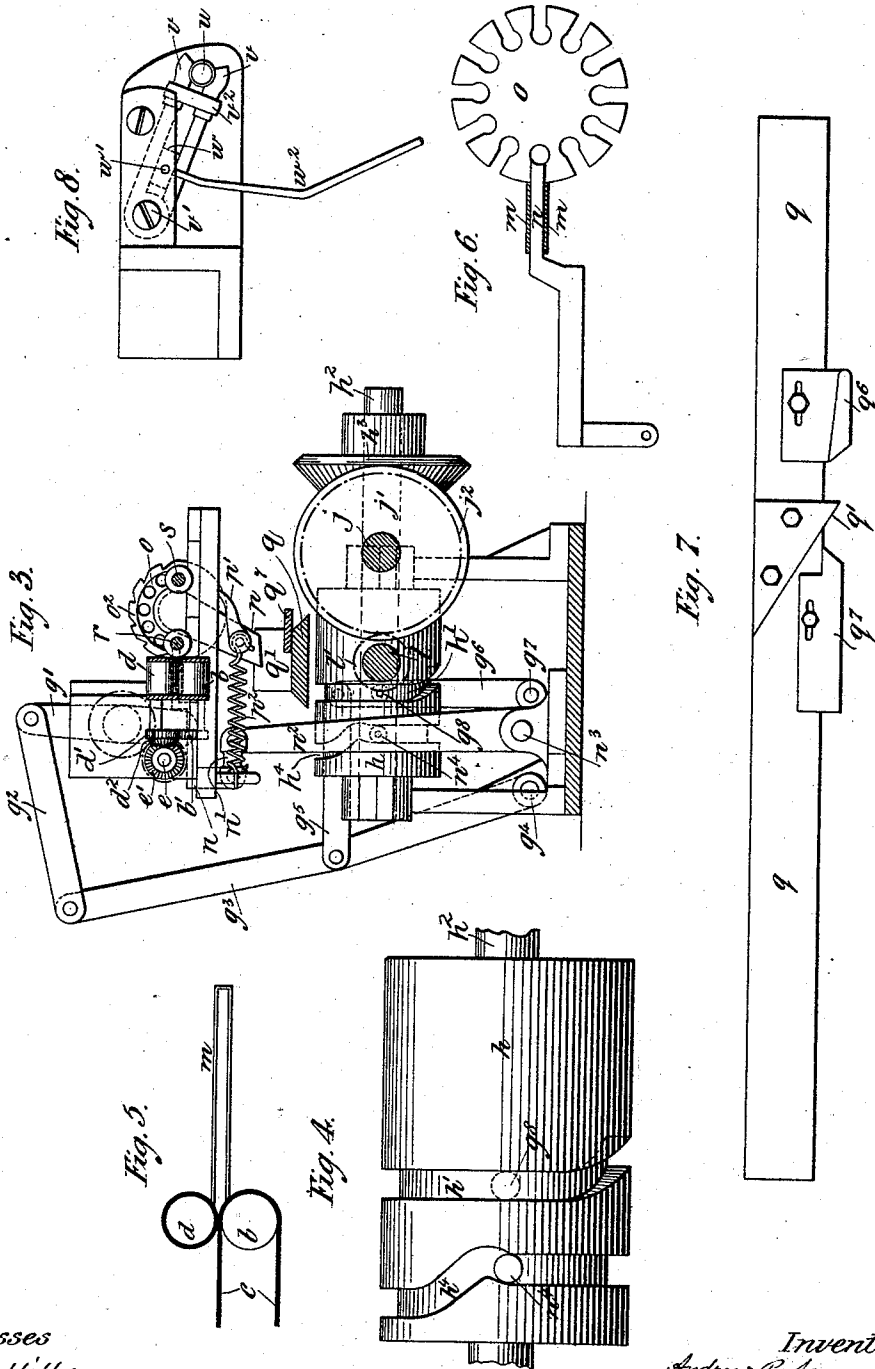

Witnesses
B. W. Miller
Sylvester Brown

Inventors
Andrew P. Scaramanga,
Eustachio P. Scaramanga,
 By their Attorneys,
Paulson Davidson & Light.

UNITED STATES PATENT OFFICE.

ANDREW PANTIA SCARAMANGA AND EUSTRATIO PANTIA SCARAMANGA,
OF LONDON, ENGLAND.

CIGARETTE-MACHINE.

SPECIFICATION forming part of Letters Patent No. 525,060, dated August 28, 1894.

Application filed May 7, 1894. Serial No. 510,379. (No model.)

To all whom it may concern:

Be it known that we, ANDREW PANTIA SCARAMANGA, a naturalized British subject, and EUSTRATIO PANTIA SCARAMANGA, a subject of the King of Greece, both residing at 110 Cannon Street in the city of London, England, have invented certain new and useful Improvements in Cigarette-Machines, of which the following is a specification.

This invention relates to improvements in the machine described in Patent No. 522,620, dated July 10, 1894. In the present machine the tobacco is placed (by hand or mechanically) lengthwise of the fiber into a narrow trough having a roller at each end carrying an endless band which forms the bottom of the trough. Above the roller at the mouth of the trough and geared with it is a feed roller which is turned intermittently driving the other two rollers and the endless band and by this means portions of the tobacco are intermittently fed from the trough between the rollers into a box open on three sides on the other side of the rollers.

A pusher usually having a concave end forces the tobacco transversely out of the box into one of a series of slots formed in cylindrical block and there strongly compresses it. The pusher is then slightly withdrawn in order to form with the slot a complete cylindrical or other shaped mold. The paper tube is held at one end of the mold by a pair of fingers and a propelling pin pushes the tobacco into it as in our former machine. Attached to and working with the propelling pin is a mold cleaner or cleaners which in form resemble the propelling pin with a washer preferably of leather fixed to it. The propelling pin may also have a cleaning ring attached to it. The cylindrical block is given an intermittent rotary movement so that each slot is used as a mold and each slot is cleaned in turn.

Figure 1 is a side elevation and Fig. 2 a plan of a machine constructed according to this invention. Fig. 3 is a section on the line 3—3 Figs. 1 and 2. Fig. 4 shows the cylinder *h* to a larger scale. Fig. 5 is a part side elevation showing the rollers *b* and *d*, band *c* and box *m* to a larger scale. Fig. 6 is a part end

elevation showing the box *m* pusher *n* and slotted cylinder *o* to a larger scale. Fig. 7 is a detached plan view of the slide *q*. Fig. 8 is a detached end elevation showing the paper holding mechanism.

a is a trough, *b b* two rollers in it, *c* an endless band on them and *d* another roller. The rollers *b* and *d* are geared together by the pinions *b'* *d'* (Fig. 3) fixed to them. *d*² is a bevel pinion on the roller *d* gearing with the bevel pinion *e'* on the shaft *e* whose other end carries the spur pinion *e*² gearing with the wheel *f'* on the shaft *f*. This shaft also has fixed to it the ratchet wheel *f*² driven by a pawl *g* on the lever *g'* pivoted on the shaft *f*. The lever *g'* is connected by the link *g*² to the rocking lever *g*³ pivoted at *g*⁴ and this in its turn is connected by the link *g*⁵ to the rocking lever *g*⁶ pivoted at *g*⁷. The lever *g*⁶ has a bowl *g*⁸ upon it which works in the cam groove *h'* in the cylinder *h* (shown to a larger scale at Fig. 4) whose axis *h*² carries the bevel wheel *h*³ gearing with the bevel wheel *j'* upon the shaft *j* which also carries the toothed wheel *j*² gearing with the pinion *l'* on the main shaft *l*.

m is a box, shown to a larger scale at Figs. 5 and 6, it has three sides namely a top, bottom and one end (the right hand end in Fig. 5) but is open on the other three sides. Each time the roller *d* is turned, as above described, this box is filled with tobacco.

n is a pusher shown to a larger scale at Fig. 6, it is connected by a link *n'* to a rocking lever *n*² (Fig. 3) pivoted at *n*³ and carrying a bowl *n*⁴ working in the cam groove *h*⁴ in the cylinder *h* (Fig. 4).

o is a slotted cylinder, shown to a larger scale in Fig. 6, it is mounted on an axle *o'* and has a ring *o*² of ratchet teeth at one end. It has a step by step motion of rotation given to it by a pawl *p'* on a lever *p* pivoted on the shaft *o'*. The lever *p* is pulled in one direction by the spring *p*² fixed to it whose other end is fixed to a projection on the under side of the frame of the machine and is moved in the other direction by the incline *q'* on the slide *q* shown separately at Fig. 7. This slide has on its under side a bowl *q*² working in the cam groove *l*² in the cylinder *l*³ mounted on

55

60

65

70

75

80

85

90

95

100

the main shaft l . r is a pusher and s a cleaning rod. These are fixed to brackets r' and s' fixed to the slide t working in the guide t' fixed to the bed of the machine and the block q^{2x} on the slide q .

q^3 is a bolt working in the block q^{2x} and it carries at one end the bowl q^4 working in the cam groove q^5 in the bed of the machine. As the slide q works to and fro the bowl q^4 alternately connects and disconnects the slides q and t so that the pusher r and cleaning rod s travel with the slide q during part only of its course.

Fig. 8 shows the paper holding mechanism which for clearness is omitted from Figs. 1 to 3. It consists of a short nozzle u which in Figs. 1 and 2 is just to the right of the slotted cylinder o and is a continuation of the mold formed by one of its slots and the pusher n .

The paper tubes are put on this nozzle and are held there by the jaws $v v$ pivoted at v' and drawn together by the elastic band v^2 . w is a block pivoted at w' and situated between the jaws v . w^2 is an arm fixed to the block w its end lying in the path of the projections $q^6 q^7$ (Fig. 6) on the slide q . When the slide q moves from left to right of Fig. 7 the end of the arm w^2 first rides along the top (in that figure) of the projection q^6 the jaws v being held open by reason of the turning of the block w between them. When the arm w^2 comes to the end of the projection q^6 the jaws v close to be again opened when the arm w^2 passes along the bottom (in Fig. 7) of the projection q^7 for it is to be observed that whichever way the arm w^2 is deflected the jaws v are opened. When the slide q moves from right to left arm w^2 passes along the bottom (in Fig. 7) both of projections q^7 and q^6 .

The cylinder o , shown in Fig. 6, is turned intermittently to present the molds or slots in succession in front of the mouth of the box m , and the pusher n is so timed as to push a charge of tobacco from the box m into a slot at each step-by-step actuation of the cylinder.

In place of turning the cylinder o one step for each cigarette, several cigarettes might be compressed in succession in the same slot and

the cylinder o may be turned by hand when necessary instead of automatically.

What we claim is—

1. The combination of a cylinder capable of revolving on its axis and having a number of longitudinal slots in its surface, a pusher for feeding tobacco radially into the slots and means for pushing the tobacco longitudinally out of the slots.

2. The combination of a cylinder capable of revolving on its axis and having a number of longitudinal slots in its surface, a pusher for feeding tobacco radially into the slots, and means for pushing the tobacco longitudinally out of the slots and for cleaning them.

3. The combination of the main frame, the cylinder o having a number of longitudinal slots in its surface mounted to revolve in the main frame, means for actuating the cylinder, means for feeding tobacco to the cylinder, a pusher n , mechanism for actuating it to force tobacco radially into the slots of the cylinder, reciprocating rods r and s , and means for actuating them to pass longitudinally into the slots of the cylinder to push tobacco from the slots and to clean them.

4. The combination of a box open on three sides, means for feeding tobacco into the box lengthwise of the fiber, a mold, a pusher working transversely to the box and carrying tobacco from it into the mold and means for actuating the pusher.

5. The combination of the trough a , a band c , working therein, rollers on which the band is mounted, a feed roller d between which and the band the tobacco is fed, a box m into which the tobacco is fed by the endless band and feed roller, a pusher n reciprocating in the box, means for actuating the band and rollers, mechanism for actuating the pusher, a slotted cylinder o , means for actuating it, rods r and s reciprocating into the slots, and means for actuating the rods.

ANDREW PANTIA SCARAMANGA.

EUSTRATIO PANTIA SCARAMANGA.

Witnesses:

GEO. J. B. FRANKLIN,

T. J. OSMAN.