

(No Model.)

4 Sheets—Sheet 1.

H. F. CRANDALL.
GRAIN BINDER.

No. 524,312.

Patented Aug. 14, 1894.

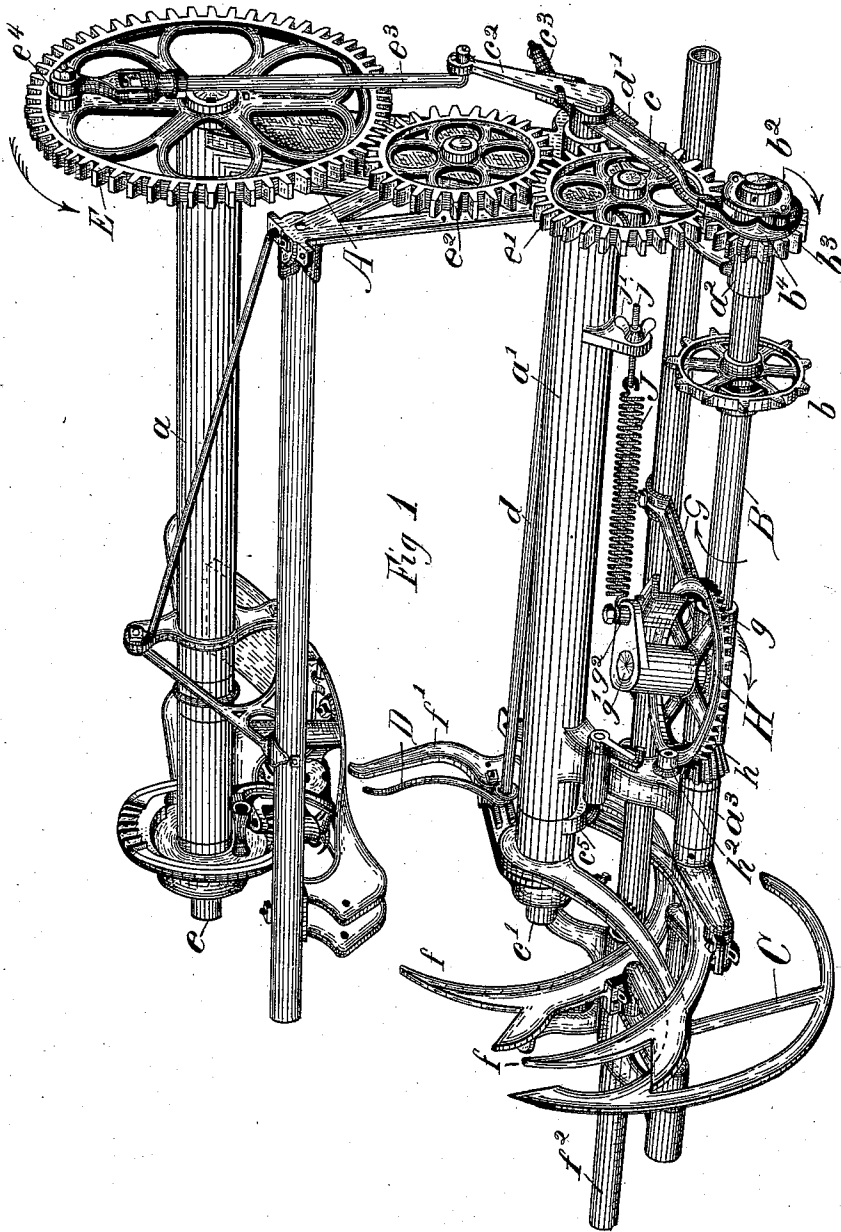

Witnesses
C. O. Holmes
W. G. Scott.

Inventor
Henry F. Crandall.
By his Attorney J. W. Latimer.

H. F. CRANDALL.
GRAIN BINDER.

No. 524,312.

Patented Aug. 14, 1894.

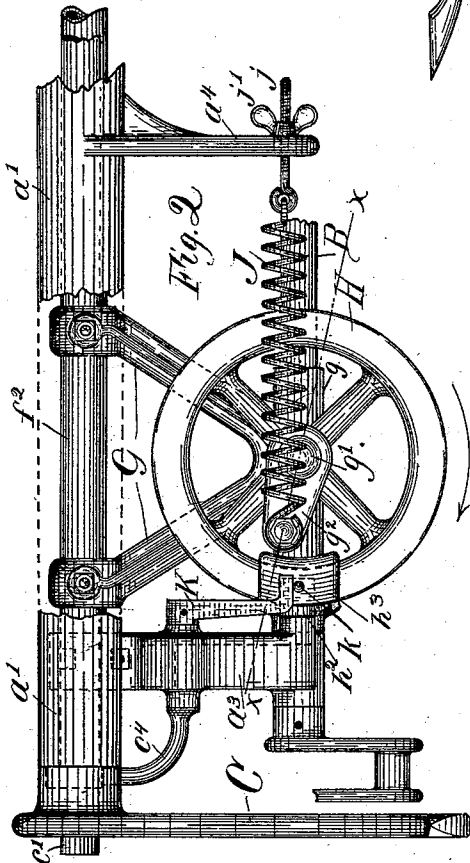
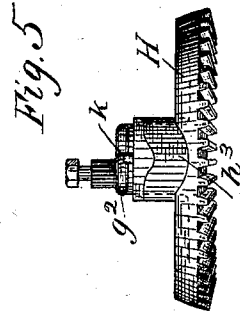
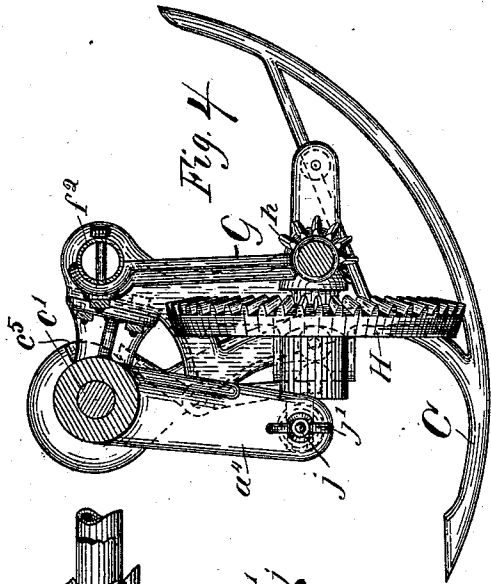

Fig. 2

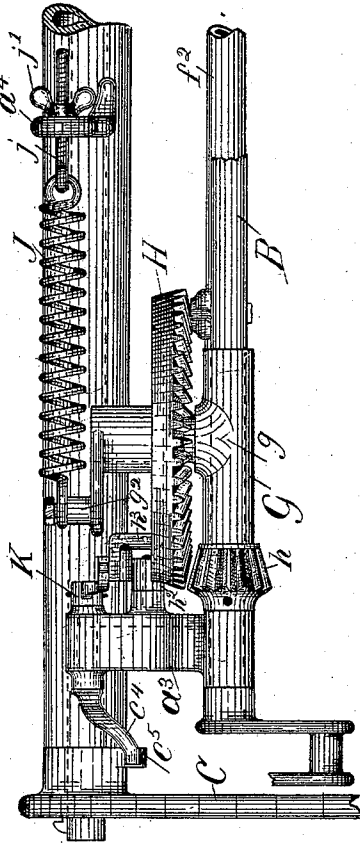

Fig. 3

Witnesses
E. O. Holmes
W. B. Scott.

Inventor
Henry F. Crandall

By his Attorney J. W. Latimer

(No Model.)

4 Sheets—Sheet 3.

H. F. CRANDALL.
GRAIN BINDER.

No. 524,312.

Patented Aug. 14, 1894.

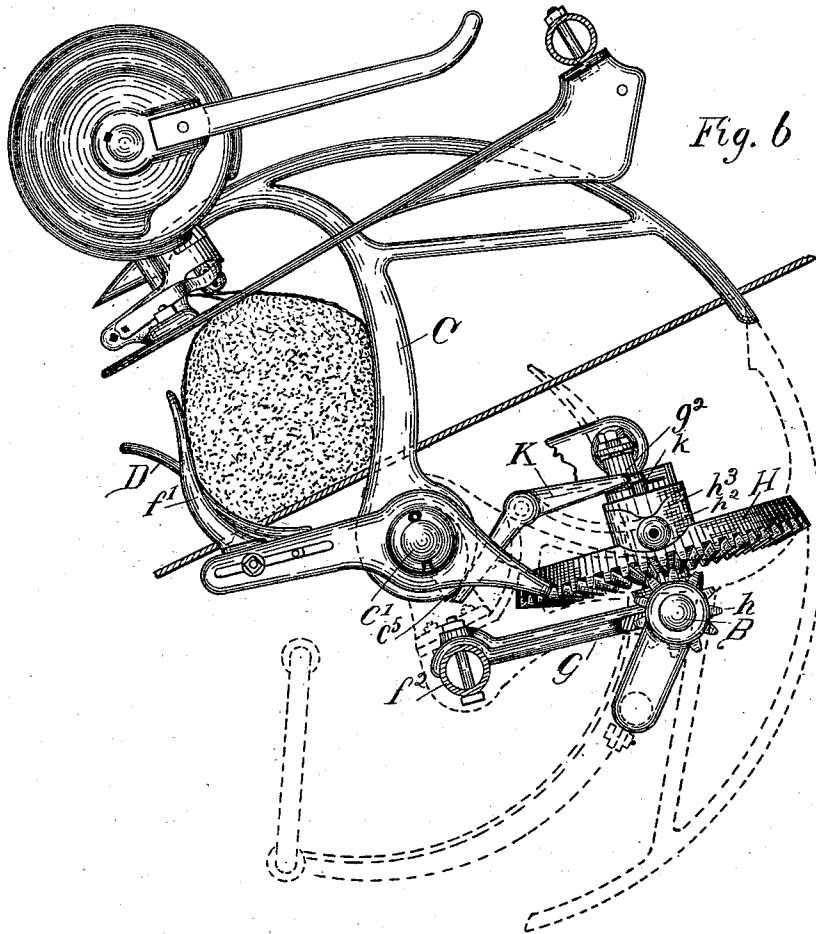

Witnesses
C. O. Holmes
W. G. Scott,

Inventor
Henry F. Crandall
By his Attorney J. W. Latimer

(No Model.)

4 Sheets—Sheet 4.

H. F. CRANDALL,
GRAIN BINDER.

No. 524,312.

Patented Aug. 14, 1894.

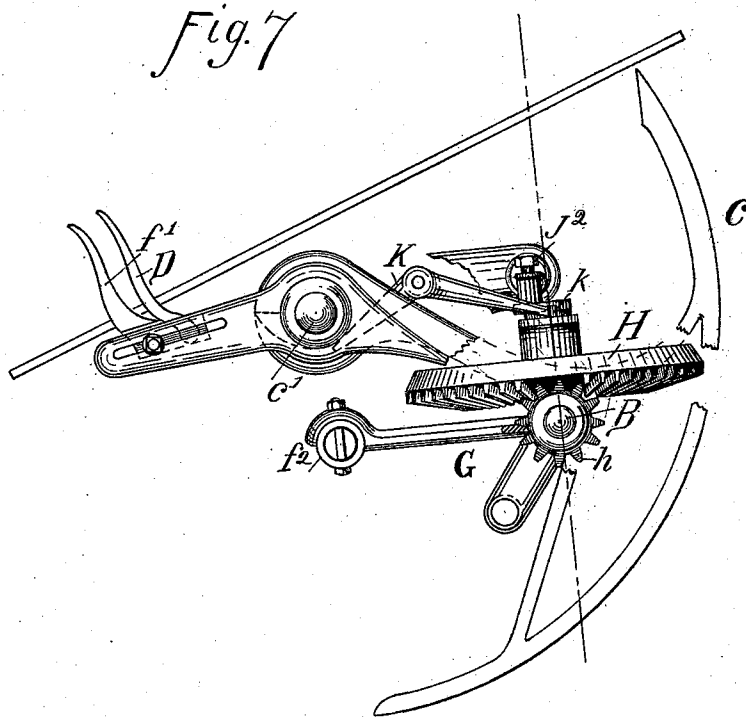
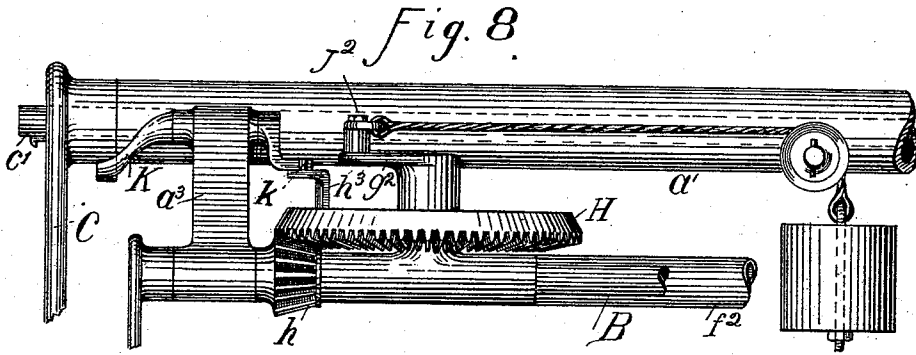

Witnesses:
E. J. Birkett.
G. L. Adams.

Inventor
Henry F. Crandall,
By J. W. Latimer,
Attorney.

UNITED STATES PATENT OFFICE.

HENRY F. CRANDALL, OF MILWAUKEE, WISCONSIN, ASSIGNOR TO THE MILWAUKEE HARVESTER COMPANY, OF SAME PLACE.

GRAIN-BINDER.

SPECIFICATION forming part of Letters Patent No. 524,312, dated August 14, 1894.

Application filed January 3, 1893. Serial No. 456,981. (No model.)

To all whom it may concern:

Be it known that I, HENRY F. CRANDALL, a citizen of the United States, residing at Milwaukee, in the county of Milwaukee and State of Wisconsin, have invented certain new and useful Improvements in Grain-Binders; and I do hereby declare that the following is a full, clear, and exact description of the invention, which will enable others skilled in the art to which it pertains to make and use the same, reference being had to the accompanying drawings, and to the letters of reference marked thereon, which form a part of this specification.

My invention relates to that class of grain binders in which the grain as it is delivered from the harvester into the binder is formed into gavels by the action of packers and compressed into compact form for binding between the needle and an opposing compressor arm.

It is well known by those familiar with the operation of self-binding harvesters, that the greatest amount of power is required when the needle compresses a gavel and that when the bundles are unusually heavy or large the power as heretofore and ordinarily communicated to the needle is almost, and sometimes altogether, insufficient, and the binder is consequently choked, thereby seriously impeding or stopping the operation of the machine.

To remedy this difficulty is the main object of my improvement, which consists essentially of a power storing device arranged to intermittently connect with the driving mechanism, and adapted during the formation of gavels in the binder to receive and store power, a trip arranged to automatically release the power previously stored, which is applied to the assistance of the binding mechanism during the operation of compressing the gavels, and certain novel features in the construction and arrangement of the component parts of the machine hereinafter described and pointed out in the claims.

In the accompanying drawings like letters designate the same parts in the several figures.

Figure 1 is a perspective view of a grain binder embodying my improvements. Fig. 2 is a plan view on an enlarged scale of the

power storing device and parts of the binder immediately associated therewith. Figs. 3 and 4 are side and end elevations, respectively, of the device shown in Fig. 2. Fig. 5 is an edge view of the bevel gear which constitutes a part of the power storing device, showing the cam by which said gear is disengaged from its driving pinion. Fig. 6 is a front elevation of the binder showing in full lines the needle in the operation of compressing a gavel, and the trip pawl about to release the gear wheel of the power storing device, and Figs. 7 and 8 are respectively end and side views of modifications of my invention.

A represents the main frame of the binder, constructed in the usual manner, with two parallel tubular arms a and a' , the former carrying the knoter shaft, and the latter the needle shaft.

B is a continuously rotating shaft driven through a sprocket wheel b from any convenient part of the harvester and supported in suitable bearings parallel with the needle shaft by cross sills a^2 and a^3 projecting from arm a' of the binder frame. Mounted loosely upon shaft B is a pinion b^3 provided with a dog b^4 which is pivoted to one side thereof and adapted to engage with the driver b^2 secured upon the rear end of said shaft B. The dog b^4 is held out of engagement with the driver b^2 by means of a stop arm c which is loosely mounted upon the needle shaft c' and yieldingly connected with the needle crank c^2 by a hook bolt and spring.

d is the trip shaft supported in suitable bearings parallel with the needle shaft c' and provided at its front end with a trip arm D and at its rear end with an arm d' extending under and adapted to raise the stop arm c out of engagement with the dog d^4 whenever the pressure of the inflowing grain turns the trip arm D outwardly, and thereby trips the binding mechanism into gear.

The packers f, f' , actuated by cranks on the continuously rotating shaft B, operate to accumulate the grain against the trip arm D in the usual manner.

f' is the compressor arm against which the needle arm C compresses the grain. It is arranged to drop below the binder deck at the proper time for discharging the bundles, and

to resume its upright position as the needle descends below the binder deck.

E is a gear wheel mounted upon the knoter shaft and driven by pinion b^3 through intermediate gear wheels e^1 and e^2 as shown in Fig. 1. A wrist pin e^4 upon gear wheel E connected by a pitman e^3 with the needle crank c^2 causes the vibration of the needle C as the wheel E revolves.

No claim is made herein to the particular construction and arrangement of the parts hereinbefore mentioned, but they are shown and described as suitable for use in connection with my improvements, and for the purpose of more fully and clearly illustrating their application to a binder and their mode of operation.

Referring now to the power storing device or mechanism constituting an essential part of my invention, G is a bifurcated frame or support bolted to a pipe sill f^2 of the binder frame and formed or provided with a sleeve g , which is loosely mounted upon and supported by the shaft B. Upon a vertical stud g^1 projecting upwardly from frame G is journaled a gear wheel H which alternately drives and is driven by a pinion h fixed on shaft B.

The support G may be formed integrally with the binder frame, but when it is applied to a machine already built, the construction shown in the drawings is preferable.

J is a close coiled spring, adjustably connected at one end by a threaded rod j and thumb nut j^1 to an arm a^4 projecting from the binder frame. It is attached at its opposite end by means of tap bolt J^2 to a crank g^2 on gear wheel H. A roller h^2 journaled upon a stud projecting from sill a^3 of the binder frame over the rim of said gear wheel H holds the latter in mesh with pinion h , and a cam h^3 formed or provided on said gear wheel opposite a corresponding depression in its rim serves by engagement with said roller h^2 to raise said gear wheel when it is in the position shown in Figs. 2, 3 and 6 out of engagement with said pinion.

The pawl K pivoted in sill a^3 is arranged to engage a stop k on gear wheel H, and to arrest the movement of the latter upon its disengagement from pinion h when the spring J is strained and has just passed the line of centers of crank g^2 as indicated by dotted line $x x$, Fig. 2.

The hub of needle C is formed or provided with a cam c^3 , which is arranged to engage with an arm c^4 of pawl K as the needle advances to compress a gavel, and thereby to lift said pawl out of engagement with stop k and release gear wheel H.

The crank g^2 is placed a little in advance of stop k , which is located directly over the lowest point of cam h^3 , as shown in Fig. 5, the wheel H rotating in the direction indicated by the arrow in Fig. 2. By this arrangement, as the wheel H is passing out of engagement with pinion h , the spring J, having passed the line of centers of crank g^2 , carries said

wheel H forward until it is arrested by stop k coming in contact with pawl K, and its disengagement from pinion h is completed.

My improved binder operates as follows:

When the machine is set in motion, the continuously rotating shaft B acting through pinion h rotates gear wheel H in the direction of the arrow shown in Fig. 2, and strains the spring J. As the wheel H is raised partially out of mesh with pinion h by cam h^3 engaging roller h^2 , the spring J, having passed the line of centers of crank g^2 , continues the rotation of said wheel H and completes its disengagement from pinion h . When thus disengaged from pinion h , the wheel H is arrested by stop k coming in contact with pawl K, and the energy previously expended in straining said spring J is stored therein until the wheel H is automatically released by the needle arm C. The grain flowing into the binder is packed against the trip arm D by the action of the packers in the usual manner, and when a sufficient amount is thus accumulated to form a gavel, said trip arm yields, and through shaft d and crank arm d^1 raises stop arm c out of engagement with dog b^1 ; the dog b^1 thus released engages with driver b^2 and connects pinion b^3 with the continuously rotating shaft B, thereby setting gear wheel E in motion through intermediate gears e^1 and e^2 . The gear wheel E rotating in the direction of the arrow shown in Fig. 1 and acting through pitman e^3 , crank c^2 and shaft c^1 , raises the needle arm C to compress the gavel. When the needle arm C is in the position shown by full lines in Fig. 6, the cam c^3 acting on arm c^4 of pawl K raises said pawl K out of engagement with stop k and thereby releases said gear wheel H. When thus released, said gear wheel H is guided by the cam h^3 and roller h^2 and moved into engagement with pinion h by the contraction of spring J, and the power stored in said spring is added to that constantly applied to the rotation of shaft B and assists the binding mechanism in the compression of the gavel and the completion of its work.

I wish to be understood that I do not limit myself to the exact construction and arrangement of parts herein shown and described. For instance, the gear wheel H may be made as shown in Fig. 7 without the cam for raising it out of mesh with pinion h , three or more teeth being omitted therefrom at the proper point in its face to accomplish the same result, and in Fig. 8, in place of spring J a weight connected by a cord or chain passing over a sheave with crank g^2 as shown in Fig. 8.

I claim—

1. In a grain binder, the combination with the binding mechanism, a continuously rotating driver and means of intermittingly connecting the same, of a power storing device arranged to be intermittingly connected with said driver and to impart to the binding mechanism, during the operation of compression,

power previously received from said driver, and a trip arranged to automatically release said power storing device at the proper time, substantially as and for the purposes set forth.

5 2. In a grain binder, the combination with the binding mechanism and a continuously rotating driver, of a power storing device arranged to be intermittingly connected with and receive power from said driver, and to
10 impart to the binding mechanism during the operation of compression the power thus received from the driver, and a trip constructed and arranged to be operated by the binding mechanism, to automatically release said
15 power storing device at the proper time, substantially as and for the purposes set forth.

3. In a grain binder, the combination with the binding mechanism and a continuously rotating driving shaft provided with a pinion,
20 of a power storing device comprising a gear wheel constructed and arranged to intermittingly engage said pinion, a device connected therewith and constructed and arranged to impart to the binding mechanism during a
25 portion of the revolution of said gear power received from the driving shaft during another portion of the revolution of said gear, a stop arranged to arrest the movement of said gear when it is disengaged from said
30 pinion, and a trip arranged to automatically release said gear at the proper time, substantially as and for the purposes set forth.

4. In a grain binder, the combination with the binding mechanism and a continuously
35 rotating driving shaft provided with a pinion, of a gear arranged to intermittingly engage said pinion and provided with a crank, a spring connecting said crank with a relatively fixed support, a stop arranged to ar-
40 rest the rotation of said gear when it is disengaged from said pinion, and a trip operated by the binding mechanism to release said gear at the proper time, substantially as and for the purposes set forth.

45 5. In a grain binder, the combination with the binding mechanism and a continuously

rotating driving shaft provided with a pinion, of a gear arranged to intermittingly engage with said pinion and provided with a crank, a spring connecting said crank with a rela- 50 tively fixed support on the frame, means of adjusting the tension of said spring, a stop arranged to arrest the movement of said gear when it is disengaged from said pinion, and a trip automatically operated by the binding 55 mechanism to release said gear at or near the beginning of the operation of compression, substantially as and for the purposes set forth.

6. In a grain binder, the combination with the needle arm, an opposing compressor arm, 60 and a continuously rotating driving shaft provided with a pinion, of a gear arranged to engage intermittingly with said pinion and to impart to said needle arm during the opera- 65 tion of compression the power previously received from said driving shaft, and a trip operated by the needle arm to release said gear at or near the beginning of the operation of compression, substantially as and for the purposes set forth. 70

7. In a grain binder, the combination with the needle arm, an opposing compressor arm, and a continuously rotating driving shaft provided with a pinion, of a gear provided with a crank and with a cam, a relatively fixed 75 roller overhanging the rim of said gear and arranged by engagement with said cam to disengage said gear from said pinion, a spring connecting said crank with a relatively fixed support on the frame, a trip pawl movable 80 into and out of engagement with a stop on said gear, and a cam on the needle arm arranged to move said pawl out of contact with said stop and thereby release said gear as the 85 needle arm is advanced against the gavel to be compressed and bound, substantially as and for the purposes set forth.

HENRY F. CRANDALL. [L. s.]

Witnesses:

J. W. LATIMER,
HUBERT SCHLOEMER.