

Aug. 8, 1933.

W. GARMAN

1,921,026

COLLAPSIBLE SUPPORT FOR TABLES, CHAIRS, ETC

Filed March 1, 1932

2 Sheets-Sheet 1

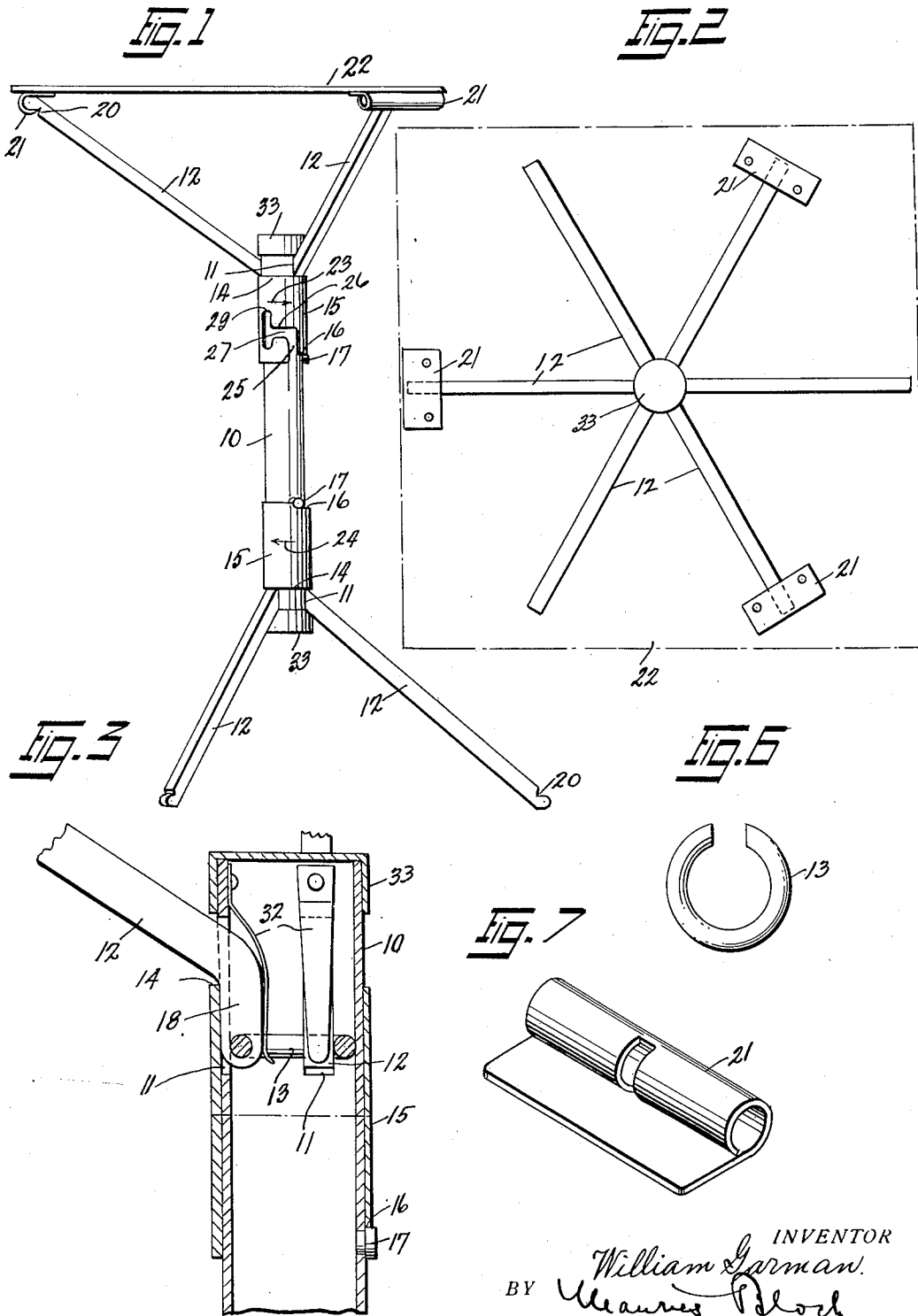

INVENTOR
William Garman.
BY *Maures Bloch*
ATTORNEY

Aug. 8, 1933.

W. GARMAN

1,921,026

COLLAPSIBLE SUPPORT FOR TABLES, CHAIRS, ETC

Filed March 1, 1932

2 Sheets-Sheet 2

Fig. 4

Fig. 5

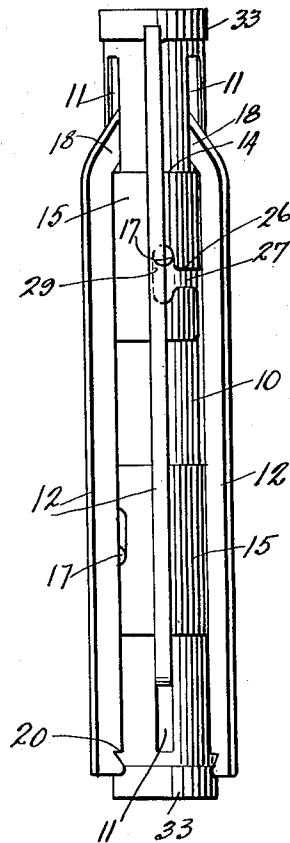
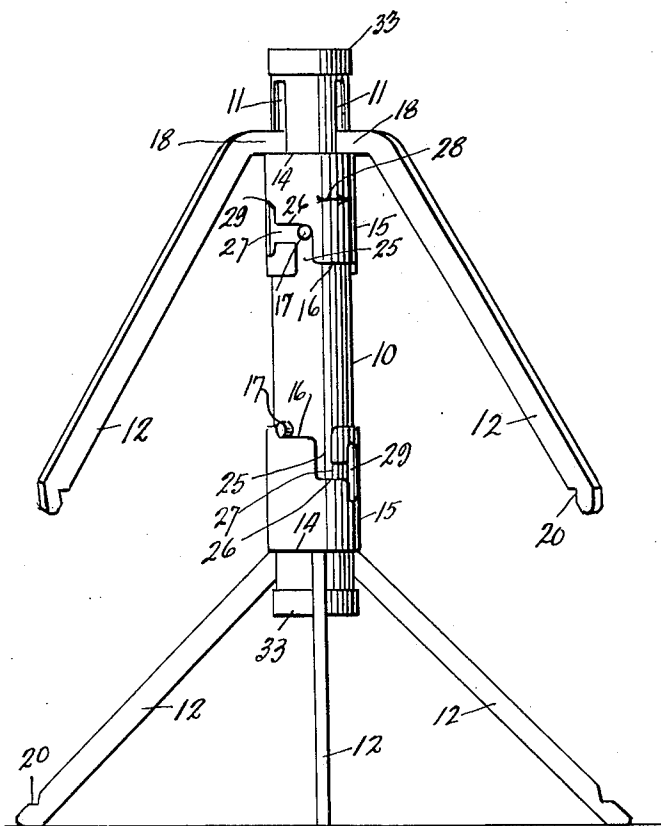

INVENTOR
William Garman
BY *Maurice Bloch*
ATTORNEY

UNITED STATES PATENT OFFICE

1,921,026

COLLAPSIBLE SUPPORT FOR TABLES, CHAIRS, ETC.

William Garman, New York, N. Y.

Application March 1, 1932. Serial No. 596,056

5 Claims. (Cl. 45—117)

This invention relates to collapsible supports for tables, chairs and the like, and has for one of its objects the provision of a support of this character, that when the said support is in collapsed or folded position it will occupy a very small space.

Another object of the invention is to provide such a support to which the table top, chair seat, or other similar object may be readily and removably secured.

A further object of the invention is to provide a support of the character referred to in which the supporting legs and the chair or table top porting legs and arms in outstretched position, and operation so as to make the support reversible.

A still further object of the invention is to provide means for releasably locking the supporting legs and arms in out stretched position.

Another object is to produce a device of the character described in which the maximum simplicity of construction and operation is secured.

Other objects and advantages will appear as the nature of the improvements is better understood, the invention consisting substantially in the novel arrangement and co-relation of parts herein fully described, and illustrated in the accompanying drawings, wherein similar reference characters are used to describe corresponding parts throughout the several views, and then finally pointed out and specifically define and indicated in the appended claims.

The disclosure made the basis of exemplifying the present inventive concept suggests a practical embodiment thereof, but the invention is not to be restricted to the exact details of this disclosure, and the latter, therefore, is to be understood from an illustrative, rather than a restrictive standpoint.

The invention idea involved is capable of receiving a variety of mechanical expressions, one of which, for the purpose of illustration, is shown in the accompanying drawings, in which—

Figure 1 is a view in elevation of my improved support with a table top or similar object secured thereto.

Figure 2 is a top plan view thereof with the table top shown in dot and dash lines.

Figure 3 is a fragmental sectional view through one end of the support.

Figure 4 is a similar view to Figure 1 but showing one set of arms or legs in partly collapsed position.

Figure 5 is a view in elevation showing the entire device in collapsed position.

Figure 6 is a plan view of the ring employed to connect the support arms, and

Figure 7 is a perspective of the fixture connecting the support arms to the table or chair.

Referring now to the drawings in detail 10 indicates a central hollow post provided at or near the top and bottom thereof with slots 11 preferably six in number, three near the top and three near the bottom end thereof. The top slots being preferably in staggered relation to 65 the bottom slots, the said slots being spaced at one hundred and twenty degrees apart.

Projecting through each of the said slots is an arm or leg 12 pivotally maintained on a ring 13 secured by welding or soldering to the inner 70 bore of the post 10 after the arms or legs are in place thereon. It is to be understood that there is one such ring for the lower arms and another for the upper arms 12. The said arms are maintained in extended position by the inner bore 75 and an edge 14 of a sleeve 15 which at its opposite edge is provided with a cutaway portion 16 in engagement with or resting upon a pin 17 in the post 10, the inner bore of the sleeve being in engagement with bent projections 18 at the pivot 80 end of the arms 12. The free ends of the arms 12 are each provided with a notch 20 for receiving a securing fixture 21 secured to the underside of a table, chair or other top 22. It is to be understood that the said fixture 21 when used in con- 85 nection with a flexible chair-seat such as canvas, may be permanently secured to the said seat but can also be slidably secured to any rigid seat or top.

To fold or collapse the arms 12, the sleeves 90 14 are revolved one at a time in the directions of the arrows 23 and 24, Figure 1, until the pin 17 rides off the surface 16 and comes into alignment with a vertical slot 25 permitting the sleeve to drop to the position indicated at the upper 95 portion of Figure 4 with the pin 17 in engagement with the upper edge 26 of a horizontal slot 27 in the sleeve 15. Upon a further rotation of the sleeve in the direction of arrow 28, Figure 4, a second vertical slot 29 will come into alignment 100 with the pin 17 and the said sleeve will drop down until the top of the said slot rests thereon, thus permitting the arms to be folded into the Figure 5 or fully collapsed position. It will be seen that the slots 25, 27 and 29 are continua- 105 tions of each other, the reason for positioning them as shown being to interrupt the drop of the arms 12 so that they may not come down too rapidly and violently and injure the hand of the person collapsing the device. To further 110

retard the downward movement of the said arms I may, if desirable, provide a spring 32 for each arm secured to the inside of the post 10 and bearing upon and exerting a slight pressure 5 or friction against the lower portions of the extensions 18. A cap 33 is provided at each end of the post 10 for closing same.

From the foregoing it will be seen that I have provided a simple, efficient and readily collapsible support for various articles of furniture, such as tables, chairs or any other article where such support can be used.

It will also be seen that due to the arrangement of the supporting arms I have provided a supporting member having a three point support at the top and bottom thereof.

I desire it understood that wherever in the claims I use the words "chair seat securing brackets" supporting brackets for any other articles are to be included.

It will be understood that instead of the three arms, 12, as shown in the drawings, I may provide four or more such arms arranged and mounted in a manner similar to that shown in the drawings.

Having described my invention what I claim as new and desire to secure by Letters Patent is:

1. A support of the nature described, comprising a hollow post provided with a plurality of slots near one end thereof, a supporting arm passing through each of the slots; a ring on the interior of the post upon which the arms are pivotally mounted, a slotted sleeve on the post in engagement at one end with the arms, and a pin on the post in engagement with the opposite end of the sleeve when the arms are in extended position and adapted to be brought into alignment with the slot in the sleeve when the said sleeve is rotated to permit same to be slid down on the post to disengage the sleeve from the arms to permit the said arms to be folded.

2. A support of the nature described, comprising a hollow post provided with a plurality of slots near one end thereof, a supporting arm passing through each of the slots, a ring on the interior of the post upon which the arms are pivotally mounted, a slotted sleeve on the post in engagement at one end with the arms, a pin on the post in engagement with the opposite end of the sleeve when the arms are in extended position and adapted to be brought into alignment with the slot in the sleeve when the said sleeve is rotated to permit same to be slid down on the post to disengage the sleeve from the arms to

permit the said arms to be folded, and springs within the post in engagement with the said arms.

3. A support of the nature described, comprising a hollow post provided with a plurality of slots near one end thereof, a supporting arm passing through each of the slots, a ring on the interior of the post upon which the arms are pivotally mounted, a sleeve on the post in engagement at one end thereof with the pivot end of the arms, and provided at its opposite end with a slot, the said slot comprising a lower and upper vertical slot section connected by a horizontal slot section, and a pin in the post in engagement with the bottom of the sleeve when the arms are extended, and in engagement with the upper edge of the horizontal slot section when the sleeve is partly rotated to bring the lower slot section in alignment with the said pin and in engagement with the upper portion of the upper slot section when the sleeve is fully rotated to completely collapse the arms.

4. A support of the nature described, comprising a hollow post provided with a plurality of slots near one end thereof, a supporting arm passing through each of the slots, a ring on the interior of the post upon which the arms are pivotally mounted, a sleeve on the post in engagement at one end thereof with the pivot end of the arms, and an abutment on the post in engagement with the opposite end of the said sleeve, the said sleeve being provided with a slot so arranged as to permit the partial folding of the arms when the sleeve is rotated a predetermined distance to bring the slot in alignment with the abutment and to permit of fully folding the arms upon a further rotation of the sleeve.

5. A support of the nature described, comprising a hollow post provided with a plurality of slots near one end thereof, a supporting arm passing through each of the slots, means on the interior of the post upon which the arms are pivotally mounted, a slotted sleeve on the post in engagement at one end with the arms, and a pin on the post in engagement with the opposite end of the sleeve when the arms are in extended position and adapted to be brought into alignment with the slot in the sleeve when the said sleeve is rotated to permit same to be slid down on the post to disengage the sleeve from the arms to permit the said arms to be folded.

WILLIAM GARMAN.

55

130

60

135

65

140

70

145

75

150