

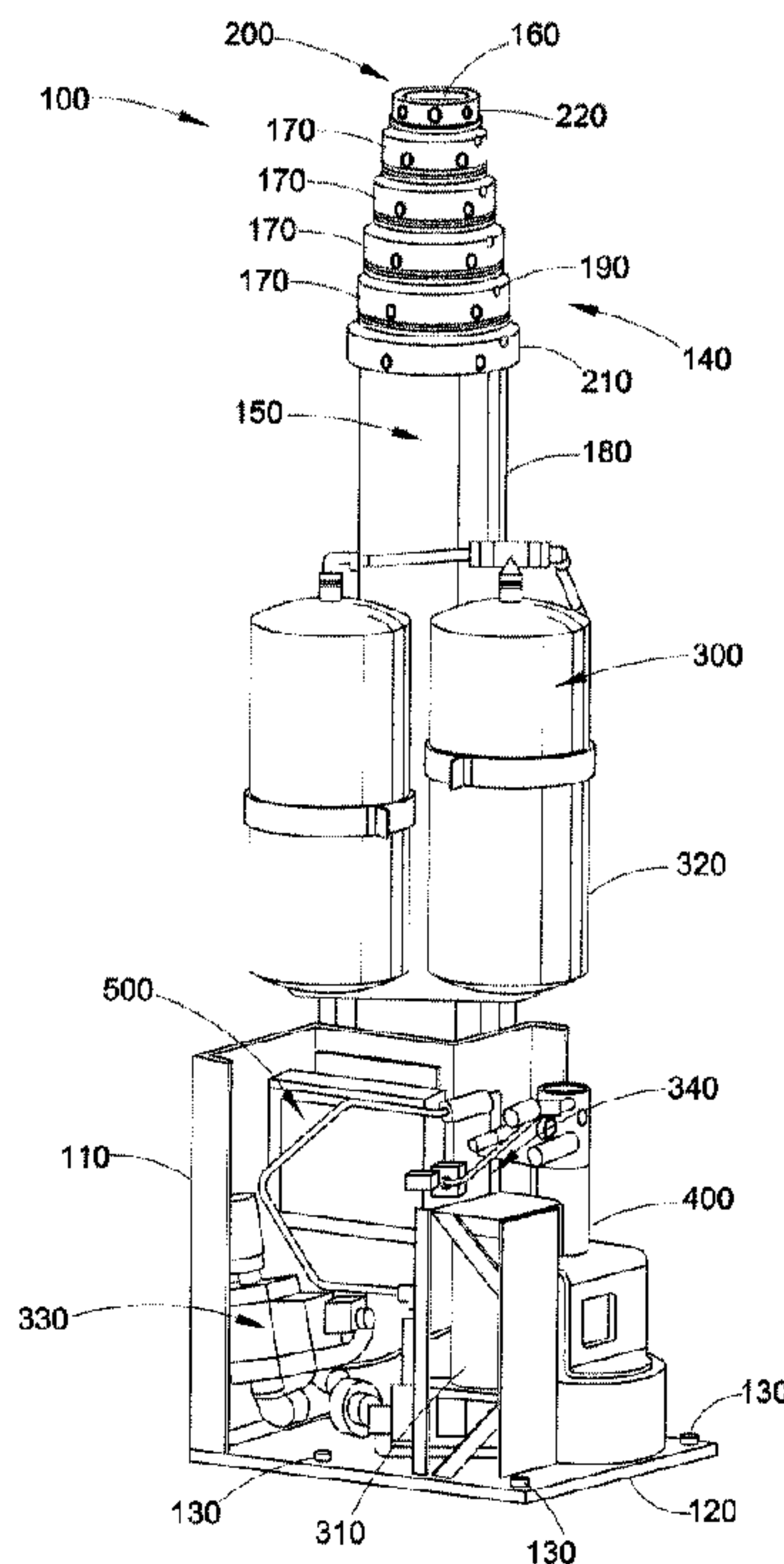

(86) Date de dépôt PCT/PCT Filing Date: 2011/06/14
 (87) Date publication PCT/PCT Publication Date: 2012/04/05
 (45) Date de délivrance/Issue Date: 2018/03/20
 (85) Entrée phase nationale/National Entry: 2013/03/27
 (86) N° demande PCT/PCT Application No.: US 2011/040294
 (87) N° publication PCT/PCT Publication No.: 2012/044378
 (30) Priorités/Priorities: 2010/09/30 (US61/388,192);
 2010/11/05 (US12/940,510)

(51) Cl.Int./Int.Cl. *E04H 12/18* (2006.01)
 (72) Inventeurs/Inventors:
 WASSON, ANDREW PAUL, US;
 KARDOHELY, MICHAEL JAMES, US
 (73) Propriétaire/Owner:
 THE WILL-BURT COMPANY, US
 (74) Agent: SIM & MCBURNEY

(54) Titre : SYSTEME DE MAT TELESCOPIQUE A DEPLOIEMENT ET RETRACTION RAPIDES
 (54) Title: RAPID DEPLOYMENT AND RETRACTION TELESCOPING MAST SYSTEM



(57) **Abrégé/Abstract:**

A rapid deployment and retraction telescoping mast system for controlling the height of a mast. A retraction mechanism including a resilient member, a retraction reel, a reel shaft, and a motor disposed about a frame. The resilient member extends from the retraction reel and is rigidly attached to a top tube of the mast through a sealed passage. The reel shaft rotates the retraction reel and winds the resilient member creating a retraction force on the top tube causing controlled retraction of the mast. A deployment mechanism including a compressor, storage tank, exhaust valve and isolation valve arranged about the frame and in communication with the mast. The compressor generates pressurized air to be communicated to the mast when the isolation valve is in the open position. The increase of pressure generated by the deployment mechanism provides a force within the mast thereby controlling its deployment.

(12) INTERNATIONAL APPLICATION PUBLISHED UNDER THE PATENT COOPERATION TREATY (PCT)

(19) World Intellectual Property Organization
International Bureau(43) International Publication Date
5 April 2012 (05.04.2012)(10) International Publication Number
WO 2012/044378 A1(51) International Patent Classification:
E04H 12/18 (2006.01)44691 (US). **KARDOHELY, Michael, James** [US/US];
10745 N. Elyria Rd., West Salem, OH 44287 (US).(21) International Application Number:
PCT/US2011/040294(74) Agent: **ZANGHI, John, S.**; Fay Sharpe LLP, The Halle
Building, 5th Floor, 1228 Euclid Avenue, Cleveland, OH
44115-1843 (US).(22) International Filing Date:
14 June 2011 (14.06.2011)(81) Designated States (*unless otherwise indicated, for every
kind of national protection available*): AE, AG, AL, AM,
AO, AT, AU, AZ, BA, BB, BG, BH, BR, BW, BY, BZ,
CA, CH, CL, CN, CO, CR, CU, CZ, DE, DK, DM, DO,
DZ, EC, EE, EG, ES, FI, GB, GD, GE, GH, GM, GT,
HN, HR, HU, ID, IL, IN, IS, JP, KE, KG, KM, KN, KP,
KR, KZ, LA, LC, LK, LR, LS, LT, LU, LY, MA, MD,
ME, MG, MK, MN, MW, MX, MY, MZ, NA, NG, NI,
NO, NZ, OM, PE, PG, PH, PL, PT, RO, RS, RU, SC, SD,
SE, SG, SK, SL, SM, ST, SV, SY, TH, TJ, TM, TN, TR,
TT, TZ, UA, UG, US, UZ, VC, VN, ZA, ZM, ZW.

(25) Filing Language: English

(26) Publication Language: English

(30) Priority Data:
61/388,192 30 September 2010 (30.09.2010) US
12/940,510 5 November 2010 (05.11.2010) US(71) Applicant (*for all designated States except US*): **THE
WILL-BURT COMPANY** [US/US]; 169 South Main
Street, Orrville, OH 44667-0900 (US).

(72) Inventors; and

(75) Inventors/Applicants (*for US only*): **WASSON, An-
drew, Paul** [US/US]; 8091 James Road, Wooster, OH(84) Designated States (*unless otherwise indicated, for every
kind of regional protection available*): ARIPO (BW, GH,
GM, KE, LR, LS, MW, MZ, NA, SD, SL, SZ, TZ, UG,
ZM, ZW), Eurasian (AM, AZ, BY, KG, KZ, MD, RU, TJ,
TM), European (AL, AT, BE, BG, CH, CY, CZ, DE, DK,

[Continued on next page]

(54) Title: RAPID DEPLOYMENT AND RETRACTION TELESCOPING MAST SYSTEM

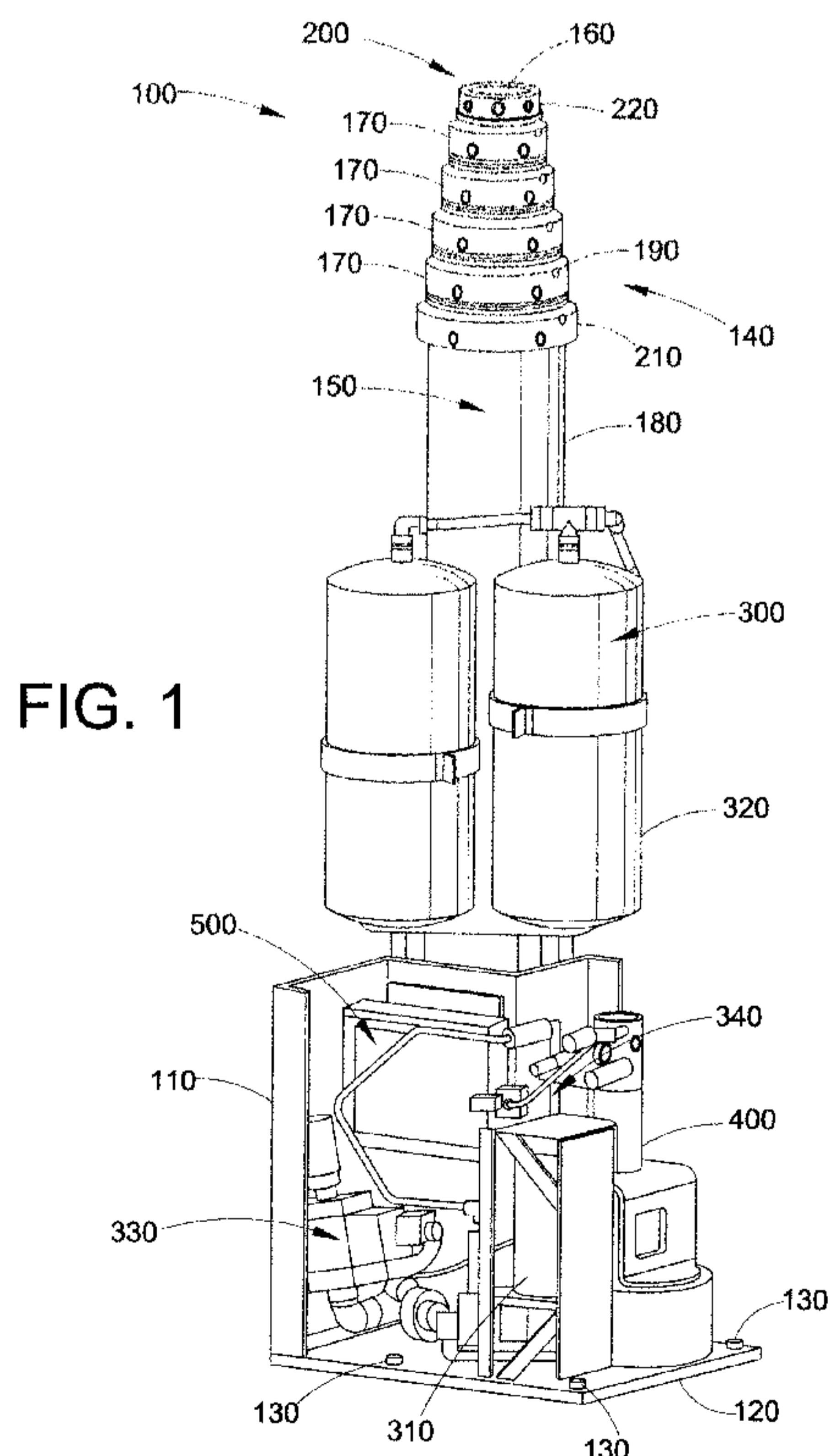

(57) Abstract: A rapid deployment and retraction telescoping mast system for controlling the height of a mast. A retraction mechanism including a resilient member, a retraction reel, a reel shaft, and a motor disposed about a frame. The resilient member extends from the retraction reel and is rigidly attached to a top tube of the mast through a sealed passage. The reel shaft rotates the retraction reel and winds the resilient member creating a retraction force on the top tube causing controlled retraction of the mast. A deployment mechanism including a compressor, storage tank, exhaust valve and isolation valve arranged about the frame and in communication with the mast. The compressor generates pressurized air to be communicated to the mast when the isolation valve is in the open position. The increase of pressure generated by the deployment mechanism provides a force within the mast thereby controlling its deployment.

WO 2012/044378 A1

WO 2012/044378 A1 

EE, ES, FI, FR, GB, GR, HR, HU, IE, IS, IT, LT, LU, **Published:**
LV, MC, MK, MT, NL, NO, PL, PT, RO, RS, SE, SI, SK, — *with international search report (Art. 21(3))*
SM, TR), OAPI (BF, BJ, CF, CG, CI, CM, GA, GN, GQ,
GW, ML, MR, NE, SN, TD, TG).

RAPID DEPLOYMENT AND RETRACTION TELESCOPING MAST SYSTEM

[0001] The present application claims priority to U.S. Provisional Patent Application Serial No. 61/388,192 filed on September 30, 2010.

BACKGROUND

[0002] The present exemplary embodiment relates to a rapid deployment and retraction telescoping mast system. It finds particular application in conjunction with telescoping masts relating to police, fire fighting, rescue, security, military, and communication industries, and will be described with particular reference thereto. However, it is to be appreciated that the present exemplary embodiment is also amenable to other like applications.

[0003] Telescoping mast systems can be operated in a variety of ways. It is common in the art to operate telescoping mast systems automatically by hydraulic or pneumatic actuation whereby a series of tubes are expanded to a desired height from a nested position by pressurized fluid or gas. In this instance, the mast is in communication with a compressor and/or a pressurized tank to provide pressurized fluid or gas to a series of cylindrical tubes. However, it is also known to operate the extension and retraction of a mast by mechanical means comprising a series of cables, ropes, winches or pulleys.

[0004] The body of the mast includes a series of tubes that typically comprise cylindrical shaped bodies, each having a generally hollow interior wherein each cylinder is interconnected with a passage for communication therethrough. Each tube generally has a flanged lip radially disposed away from a central axis at a bottom end and a flanged lip radially disposed toward the axis at a top end. The tubes concentrically engage one another wherein the exterior tube has a width greater than a first intermediate tube disposed therein. The first intermediate tube having a greater width than a second intermediate tube disposed therein and so on. This arrangement can comprise any number of tubes wherein the pinnacle of the mast includes a top tube

having a width that is smaller than any other tube in the mast. The top tube is attached to the load intended to be deployed and/or retracted.

[0005] The plurality of tubes comprises a pressurized envelope that is typically achieved with a gasket or sleeve disposed between each tube. The sleeve can be made of an elastomeric or rubber type compound and maintains a seal between each tube while also allowing movement without pressure seepage. The tubes are deployed to a desired height and can be secured in place by maintaining the pressure within the mast.

[0006] Retraction of the mast is generally achieved by allowing gravitational forces to return the tubes and associate load to a nested position. This requires pressure to be vented from the envelope which is a function of the gravitational pull, the friction between the sleeves and tubes and the weight of the mast and load. The speed of this retraction is dependent on the payload weight and the surrounding environmental conditions.

[0007] Retractable poles and masts have been fabricated mostly from aluminum, with a few devices made of fiberglass. Such prior designs are typically bulky and may use complicated networks of pressurized air, cables, and pulleys to extend or collapse the poles, resulting in a time-consuming operation each time the apparatus is to be extended or retracted.

[0008] Pneumatic telescoping mast systems are typically retracted by opening an air release valve and allowing gravity to return the tubes and payload to the nested position. The speed of this retraction is dependent on the payload weight and the surrounding environmental conditions.

[0009] However, retraction of such a pole by its own weight necessitates the use of a pole with sufficient weight to accomplish such retraction in an efficient manner. Depending on the application, this variable retraction speed can pose risk to an associate operator and overall efficiency of the system. Therefore, it is desirable to have a rapid deployment and retraction mast to allow the operator the ability to quickly deploy and retract the mast in a consistent and repeatable fashion. There remains a need for a device and method for a controlled extendable and retractable telescoping mast which may be both quickly extended and retracted.

BRIEF DESCRIPTION

[0010] The present disclosure relates to a rapid deployment and retraction telescoping mast system. The disclosed system comprising a frame including a base for connection to an associate surface and a plurality of interconnected tube sections vertically disposed on the base. The tube sections including a base tube and a top tube and at least one intermediate tube there between. Each tube section comprising a generally hollow body wherein each tube is axially aligned with each of the plurality of tubes and defining a shared passage therethrough. The plurality of tube sections maintains an envelope having a pressurized seal arrangement.

[0011] One object of the disclosure provides a deployment mechanism including a compressor, storage tank, exhaust valve and isolation valve arranged about the frame and in communication with the plurality of interconnected tube sections. The compressor is in communication with the storage tank to generate pressurized air for storage in the tank. The storage tank is in communication with the plurality of tubes in series arrangement with the isolation valve wherein the tank becomes isolated from the plurality of tubes during non-operation while the isolation valve is closed. Compressed air is introduced into the plurality of tubes when the isolation valve is in the open position wherein increasing the pneumatic pressure within the sealed envelope of the plurality of tubes. The increase of pressure generated by the deployment mechanism provides a deployment force within the plurality of interconnected tubes causing controlled deployment of the telescoping mast.

[0012] An additional object of the disclosure provides a retraction mechanism including a resilient member, a retraction reel, a reel shaft, and a motor disposed about the frame. The retraction reel and at least a portion of the reel shaft are disposed within a sealed housing. The resilient member extends from the retraction reel and is rigidly attached to the top tube of the plurality of tube sections through a resilient passage. The resilient passage is sealed and in communication with the hollow sealed passage defined by the plurality of interconnected tubes. The retraction reel includes an arcuate edge radially extending from a central axis. The resilient member rotably engages the retraction reel at the arcuate edge and the reel shaft axially engages the retraction wheel at the central axis. The reel shaft adapts to a motor to introduce mechanical force

to the retraction mechanism whereby upon operation of the motor, the reel shaft rotates the retraction reel and winds the resilient member creating a retraction force on the top tube causing controlled retraction of the telescoping mast. At the time the retraction mechanism is operated, the exhaust valve, in communication with the plurality of tubes, is opened to allow for the reduction of pressure. The exhaust valve and motor can be toggled for optimal control over the retraction speed of the mast.

[0013] In one embodiment, the plurality of telescoping tubes include sliding and sealing surfaces between the tubes, a first plug member on the upper end of the smallest cylinder, and a second plug member on the lower end of the largest cylinder, wherein pressurize air admitted to the base tube and cause the deployment of the tubes to slide relative to one another causing the mast to extend. An elastomeric sleeve connects a tube with one of the intermediate tubes to seal one tube to another when the mast is fully extended. The elastomeric sleeve further serves to provide a cushion to prevent damage to the cylinders when the pole is urged back into a nest position by the retraction mechanism and the venting of the pressure.

[0014] Yet another embodiment provides a controller box in electrical communication with the compressor, isolation valve, exhaust valve, storage tank, motor and associate sensing and controlling elements. A potentiometer device is provided about the reel shaft to communicate reel shaft frequency data to the controller box. The controller box may be used to record and store data as well as manipulate known toggleable functions of the associate elements within the system.

[0015] In yet another embodiment, a torsion spring is provided in the housing to provide a supporting force to the retracting reel therein reducing undesired slack of the resilient member.

[0016] A further embodiment provides a clutch bearing operably coupled between the reel shaft and the motor to allow free rotation of the reel shaft and retraction reel in the direction of motor rotation when not engaged. The clutch bearing also allows the transfer of torque from the motor to the reel shaft in the retraction direction when engaged.

[0017] An advantage of the present disclosure is a device that rapidly deploys and retracts a plurality of interconnected tubes with a controllable and consistent rate

[0018] In a further advantage of the present disclosure is to provide the repeatable retraction time required for a telescoping mast under all environmental conditions and mast orientations. Particularly, consistency problems for mast operation within cold temperatures and at angled grades are overcome by this disclosure.

[0019] It is also an advantage of the present disclosure to provide a telescoping mast system having a design architecture with a lower cost than other mast devices.

[0020] In accordance with an aspect of an embodiment, there is provided a telescoping mast system comprising: a frame; a plurality of interconnected tube sections including at least a base tube, an intermediate tube and a top tube, each tube section comprises a substantially hollow body; a retraction controller mechanism including a retraction reel coupled to a reel shaft, a motor and a resilient member extending therefrom, wherein the resilient member is attached to the plurality of interconnected tube sections to create a retraction force thereon, the retraction reel is located within a sealed housing, the sealed housing comprises at least a reel shaft seal; and a deployment controller mechanism in communication with the plurality of interconnected tube sections.

[0021] In accordance with another aspect of an embodiment, there is provided a telescoping mast system comprising: a frame including a base for connection to an associate surface; a plurality of interconnected tube sections including at least a base tube and a top tube; the tube sections comprising a substantially hollow body; the top tube being axially aligned with the base tube; the plurality of tube sections include a substantially pressurized seal arrangement; a retraction controller mechanism including a resilient member, retraction reel, reel shaft, and motor, the resilient member extending from the retraction reel and in communication with the top tube to provide a retraction force thereon to retract the plurality of interconnected tube sections along a common axis; the retraction reel axially engaged to the reel shaft; a deployment controller mechanism in communication with the plurality of interconnected tube sections; the deployment controller mechanism comprising a compressor, storage tank, exhaust valve and isolation valve.

[0022] In accordance with another aspect of an embodiment, there is provided a telescoping mast system comprising: a frame; a plurality of interconnected tube sections including at least a base tube, an intermediate tube and a top tube, each tube section comprises a substantially hollow body; a retraction controller

mechanism including a retraction reel, a reel shaft, a motor and a resilient member extending therefrom and in communication with the plurality of interconnected tube sections, wherein the retraction reel is located within a sealed housing and the sealed housing comprises at least a reel shaft seal; and a deployment controller mechanism in communication with the plurality of interconnected tube sections, wherein the deployment controller mechanism comprises a compressor, an exhaust valve and an isolation valve.

[0023] Still other features and benefits of the present disclosure will become apparent from the following detailed description.

BRIEF DESCRIPTION OF THE DRAWINGS

[0024] FIGURE 1 is a perspective view of the rapid deployment and retraction telescoping mast system;

[0025] FIGURE 2 is cross sectional schematic view of the retraction mechanism;

[0026] FIGURE 3 is a sectional view of the plurality of interconnecting tubes and a schematic view of the deployment mechanism and the retraction mechanism of the telescoping mast system;

DETAILED DESCRIPTION

[0027] It is to be understood that the detailed figures are for purposes of illustrating exemplary embodiments only and are not intended to be limiting. Additionally, it will be appreciated that the drawings are not to scale and that portions of certain elements may be exaggerated for the purpose of clarity and ease of illustration.

[0028] In accordance with the present disclosure a system and method are provided which automatically control the deployment and retraction of a telescoping mast system. The system can be used to provide hoisting for all types of applications including but not limited to personel lifts, communication towers, antennas, satellites, material hoists, platforms, and any other application that requires displacement from the base to a predetermined height.

[0029] The mast system combines the positive aspects of a pneumatic mast system and mechanical retraction mechanism for the purpose of rapid deployment and retraction of a telescoping mast system. The system combines the low cost benefits of a

pneumatic mast with the controlled motion and positive retraction force of a mechanical mast. Disclosed is a pneumatic mast equipped with a mechanical retraction system. This system consists of a powered reel and automated pneumatic exhaust valve. To maintain the pneumatic sealing integrity of the mast, the powered reel mechanism is integrated within a pressure vessel.

[0027] With reference to **FIGURE 1 & FIGURE 3**, a telescoping mast system **100** controls the rapid deployment and retraction of an associate load **105**. The telescoping mast system **100** includes a frame **110** for securing different elements of the system. The frame **110** includes a base **120** for adapting the telescoping mast system to an associate surface. The base **120** includes a plurality of anchors **130** for a stable connection to the surface. The anchors **130** should be rigidly connected to ensure a safe, consistent operation of the telescoping mast system **100**. It is to be understood that an unsuitable base **120** connection would increase the risk of improper operation whereby the system **100** would be subject to tipping, shaking or falling.

[0028] A plurality of interconnected tube sections **140** are vertically joined to the base **120**. The tube sections **140** include a base tube **150** and a top tube **160** with intermediate tubes **170** there between. Each tube section **140** comprises a generally hollow body **180** wherein the base tube **150** is axially aligned to the intermediate tubes **170** and the top tube **160**. The plurality of tubes **140** define a hollow shared passage **460** from the combination of hollow bodies. The plurality of tubes **140** maintain an envelope having a pressurized seal arrangement.

[0029] The plurality of tubes **140** may include a plurality of sliding and sealing surfaces **190** between the tubes **140**. The sealing surfaces **190** comprise an elastomeric sleeve **190** that connects at least the base tube **150** with one of the intermediate tubes **170** to seal one tube to another when the mast system **100** is fully extended. The elastomeric sleeve also provides a cushion to prevent damage to the cylinders when the pole is urged back into a nest position **200** as shown. The base tube **150** has a closed first end **205** opposing a second end **210** that interconnects intermediate tubes **170**. The top tube **160** has a closed first end **220** opposing a second end **230** away from the base **120**, thereby creating a sealed envelope within the hollow bodies of the plurality of tubes **140**. The sealed envelope allows pressurized air to enter the base tube **150** without

pressure leakage and helps deploy the tubes **140** relative to one another causing the mast to extend vertically.

[0030] A deployment mechanism **300** is provided about the frame **110** of the telescoping mast system to automatically control the deployment function of the system. The deployment mechanism **300** includes a compressor **310**, at least one storage tank **320**, an exhaust valve **330** and an isolation valve **340**. In the preferred embodiment of **FIGURE 1**, the compressor **310** is located on the base **120** of the frame **110** and maintains pressurized communication with the storage tank **320** while the storage tank **320** is structurally adapted to the base tube **150**. The exhaust valve **330** and isolation valve **340** are also provided about the frame **110**. It is noted that this organizational structure is not limited to this arrangement as any other structural locations for the different elements is also covered by this disclosure.

[0031] The isolation valve **340** is aligned in a passage that remains in communication between the storage tank **320** and the base tube **150**. The isolation valve **340** may comprise any type of plumbing, hydraulic or pneumatic type shut off valve known in the prior art whereas an electrical solenoid valve is preferable. The passage may comprise any durable plumbing material suitable to allow the transfer of pneumatic pressure in a controlled manner while preventing unnecessary pressure loss due to leaks. Utilizing stored energy in the form of compressed air allows rapid deployment that is not dependent on the flow rate of the compressor. The width of the passage as it exists between the isolation valve **340** and the base tube **150** can be adjusted to increase or decrease the speed of the telescoping mast deployment. Deployment speed can also be tunable by adjusting the tank pressure or volume.

[0032] When engaged into operation, the compressor **310** generates pressurized air provided to the storage tank **320**. Tank pressure is controlled by a pressure switch. The storage tank **320** remains in communication with the plurality of tubes **140** and in series alignment with the isolation valve **340** and the base tube **150**. The isolation valve **340** may be automatically toggled by one or more signals provided by a control box **500**, which is in electrical communication with the isolation valve **340**. The isolation valve **340** range between opened and closed can be modulated to provide more precise control over the pressurized air provided from the storage tank **320** to the base tube **150**.

Compressed air is introduced into the plurality of tubes **140** when the isolation valve **340** is in the open position thereby increasing the pneumatic pressure within the sealed envelope of the plurality of tubes **140**. The increase of pressure generated by the deployment mechanism provides a deployment force within the plurality of interconnected tubes. The deployment force acts on the plurality of tubes **140** to urge each tube into an extended position **350**. The isolation valve **340** remains closed during the non-operation of the system or otherwise while the system is at rest. The plurality of tubes may remain at rest while in the nest position **200** or at rest in the extended position **350**.

[0033] The retraction mechanism **400** is depicted in **FIGURES 1** and **2** but will be described in particularity as identified in **FIGURE 2**. The retraction mechanism **400** includes a resilient member **410**, a retraction reel **420**, a reel shaft **430**, and a motor **490** disposed about the base **120** of the frame **110**. The retraction reel **420** and at least a portion of the reel shaft **430** are disposed within a pneumatically sealed housing **440**. The sealed housing **440** maintains a pressurized volume by utilizing static O-ring seals **445** on the housing cover and rotating shaft U-cup seals **455** on the reel shaft **430**. The O-ring seals **445** are provided about a sealing wall **446** of a housing cover **560** and are provided in sealing engagement with the sealed housing **440** to help prevent pressure leaks. The U-cup seals **455** are provided about a sealing wall **456** of the housing cover **560** at a location surrounding the shaft reel **430**. The U-Cup seals **455** dynamically and seallingly engage the reel shaft **430** to help prevent pressure leaks from the sealed housing **440** while the reel shaft **430** is rotated. At least a portion of the reel shaft **430** is located within the sealed housing **440** and engages axial sleeve bearings **435**, **436** for consistent dynamic rotational motion between the reel shaft **430**, the sealed housing **440** and the housing cover **560**.

[0034] The motor **490** is supported and attached to a mounting bracket **520** by mechanical fasteners **590**. The housing cover **560** is seallingly attached to the sealed housing **440** by mechanical fasteners **600**. The resilient member **410** may comprise any material known in the art to that provides a connection between multiple elements allowing a pulling force sufficient to overcome a predetermined weight of a load to be

deployed and retracted. Capable resilient members **410** may include but not be limited to bungee cords, rope, chain, cable, straps, nylon, rubber, etc.

[0035] In a preferred embodiment that can be better understood by **FIGURE 3**, the resilient member **410** extends from the retraction reel **420** and is rigidly attached to the top tube **160** of the plurality of tube sections through an internal resilient passage **450**. The resilient passage **450** is sealed and defines a pressurized communication pathway between the hollow sealed passage **460** defined by the plurality of interconnected tubes **140** and the sealed housing **440**. As can be appreciated in **FIGURE 2**, the retraction reel **420** includes an arcuate edge **470** radially extending from a central axis **480**. The resilient member **410** rotably engages the retraction reel **420** at the arcuate edge **470** and the reel shaft **430** engages the retraction reel **420** in axial alignment with the central axis **480**.

[0036] The reel shaft **430** adapts to the motor **490** to introduce a rotational mechanical force to the retraction mechanism **400**. Upon operation of the motor **490**, the reel shaft **430** rotates the retraction reel **420** thereby winding the resilient member **410** about the retraction reel **420** and creating a retraction force on the top tube **160**. The top tube **160** acts on all tube sections to mechanically retract the mast. A clutch bearing **570** is provided about a clutch housing **580** within the mounting bracket **520**. The clutch housing **580** is axially aligned to the reel shaft **430** and motor **490** to allow the clutch bearing **570** to operatively engage the reel shaft **430** and to transfer the torque from the motor **490** to the reel shaft **430**. The reel shaft **430** is coupled to the clutch housing with a key and set screw arrangement. The clutch bearing **570** engages the reel shaft **430** to transfer torque provided by the motor **490** and allows the reel shaft **430** to freely rotate (freewheel) in the same rotational direction as the winding of the resilient member **410**. The clutch bearing **570** (also known as a one way bearing) is set in the clutch housing **580** with a press fit and is coupled to the motor using a key.

[0037] A torsion spring **540** is provided in the sealed housing **440** to provide a supporting force to the retraction reel **420**. This supporting force helps to reduce extra slack of the resilient member **410** that may exist in mechanical winch type systems such as this. The torsion spring **540** is a multi-turn, mechanical spring which includes a dynamic end that attaches to the retraction reel **420** with a tab and slot arrangement

550. The opposing end of the torsion spring **540** is statically attached to a housing cover **560** with a screw **575**. The torsion spring **540** acts on the retraction reel **420** in a direction that keeps the resilient member **410** in tension and generally removes the risk of slack development in the resilient member **410**. The direction of this force is the same direction as the rotational force provided by the motor **490** and the free-wheeling direction due to the clutch bearing **570** and reel shaft **430** arrangement. The torsion spring **540** is also supported by a spring retainer **585** located within the sealed housing **440**. The clutch bearing **570** allows the torsion spring torque to act without needing to energize the motor in the opposite direction. The clutch bearing **570** allows the torsion spring **540** to retract the resilient member **410** even if the rotation speed needed exceeds the retraction motor rotation speed. This might occur if gravity causes the mast to retract faster than the retraction motor speed dictates.

[0038] However, during deployment, the resilient member **410** is unwound from the retraction reel **420**. The clutch bearing **570** applies torque in the direction that causes the motor **490** to be back-driven. The dynamic end of the torsion spring **540** rotates which increases the torque to a maximum value when the plurality of tubes **140** are fully extended.

[0039] At the time the retraction mechanism **400** is operated, the exhaust valve **330**, in communication with the hollow passage **460** through the base tube **150**, is opened to allow for the reduction of pressure influencing the downward motion of the tubes **140**. The exhaust valve **330** orifice size, along with the power and speeds of the motor **490**, can be toggled along with a designed diameter of the retraction reel **470** for optimal control over the retraction speed of the mast system. Additionally, the deployment and retraction speeds are a function of the dual operation of both the deployment mechanism **300** and the retraction mechanism **400**. Adjustment or modulation of an element of the deployment mechanism **300** may have an effect on the speed of mast retraction and likewise adjustment or modulation of an element in the retraction mechanism **400** may have an effect on the speed of mast deployment.

[0040] The controller box **500** may be in electrical communication with the compressor **310**, isolation valve **340**, exhaust valve **330**, storage tank **320**, motor **490** and associate sensing and controlling elements. A potentiometer device **510** is provided

within the mounting bracket **520** of the retraction mechanism to communicate with the reel shaft **430** by way of a pulley belt **530**. Potentiometer devices are well known in the art to provide electronic computational signals in addition to other controlling features. The potentiometer **510** provides a signal to the controller box **500** indicating the rate and quantity of revolutions of the reel shaft **430** for optimal control and monitoring of the rotational speed of the retraction reel **420** and the telescoping mast system.

[0041] **FIGURE 3** provides a clear schematic depiction of the operational elements of the present disclosure and a partial cross sectional view of the plurality of tubes **140**. The resilient member **410** extends from the retraction mechanism **400** and rotationally engages a pulley member **610**. The pulley member rotationally directs the resilient member **410** towards a central axis of the plurality of tubes **140** in a generally perpendicular direction from the axis where the resilient member **410** extends from the retraction mechanism **400**. The resilient member **410** rigidly connects to the top tube **160** at the second side **230**. However, the resilient member **410** may also connect to the top tube **160** at the first side **220**.

[0042] The telescoping mast system **100** rapidly deploys and retracts a plurality of interconnected tubes **140** with a controllable and consistent rate required for a telescoping mast under all environmental conditions and mast orientations. Particularly, consistency problems for mast operation within cold temperatures and at angled grades are overcome by this disclosure. These features are functional due to the pressurized envelope of the system as it is maintained with countervailing mechanical forces in a predetermined and programmable way thereby optimizing deployment and retraction speeds of the telescoping mast. This concept is scalable to different mast heights and diameters.

[0043] This disclosure particularly overcomes environmental conditions such as cold temperatures with frost build-up on the tubes and operating the mast at grades greater than horizontal as they cause difficulty with a purely pneumatic mast in regards to retraction time.

[0044] Other concepts to provide the rapid retraction function are as follows: Draw vacuum in the mast pressure chamber to allow atmospheric pressure on the outside of the tubes to provide a downward pressure differential force to retract the mast.

[0045] The exemplary embodiment has been described with reference to the preferred embodiments. Obviously, modifications and alterations will occur to others upon reading and understanding the preceding detailed description. It is intended that the exemplary embodiment be construed as including all such modifications and alterations insofar as they come within the scope of the appended claims or the equivalents thereof.

CLAIMS:

1. A telescoping mast system comprising:
 - a frame;
 - a plurality of interconnected tube sections including at least a base tube, an intermediate tube and a top tube, each tube section comprises a substantially hollow body;
 - a retraction controller mechanism including a retraction reel coupled to a reel shaft, a motor and a resilient member extending therefrom, wherein the resilient member is attached to the plurality of interconnected tube sections to create a retraction force thereon, the retraction reel is located within a sealed housing, the sealed housing comprises at least a reel shaft seal; and
 - a deployment controller mechanism in communication with the plurality of interconnected tube sections.
2. The telescoping mast system of claim 1, wherein a torsion spring operably interacts with the retraction reel.
3. The telescoping mast system of claim 1, wherein the retraction reel is coupled to the reel shaft, said reel shaft is coupled to a clutch mechanism.
4. The telescoping mast system of any one of claims 1 to 3, wherein the deployment controller mechanism comprises a compressor, an exhaust valve and an isolation valve.
5. The telescoping mast system of claim 4, wherein the deployment controller mechanism comprises a pressurized storage tank in communication with an isolation valve and the plurality of tube sections.
6. The telescoping mast system of any one of claims 1 to 5, wherein the base tube has a first width, the intermediate tube has a second width, the end tube as a third width, wherein the first width is greater than the second width, the second width is greater than the first width.
7. The telescoping mast system of any one of claims 1 to 6, wherein each tube section comprises a substantially cylindrical shaped body.

8. A telescoping mast system comprising:
a frame including a base for connection to an associate surface;
a plurality of interconnected tube sections including at least a base tube and a top tube; said tube sections comprising a substantially hollow body; said top tube being axially aligned with the base tube; said plurality of tube sections include a substantially pressurized seal arrangement;
a retraction controller mechanism including a resilient member, retraction reel, reel shaft, and motor, said resilient member extending from the retraction reel and in communication with the top tube to provide a retraction force thereon to retract the plurality of interconnected tube sections along a common axis; said retraction reel axially engaged to the reel shaft;
a deployment controller mechanism in communication with the plurality of interconnected tube sections; said deployment controller mechanism comprising a compressor, storage tank, exhaust valve and isolation valve.
9. The telescoping mast system of claim 8, wherein the retraction controller mechanism includes a means to induce rigidity of the resilient member.
10. The telescoping mast system of claim 9, wherein the means to induce rigidity of the resilient member includes a clutch mechanism in axial alignment with said reel shaft and said motor wherein said clutch mechanism allows for the at least one of a torque rotation and free rotation of said retraction reel.
11. The telescoping mast system of any one of claims 8 to 10 further including a controller box, said controller box provides electronic control to the retraction mechanism and deployment mechanism.
12. The telescoping mast system of any one of claims 8 to 11, wherein the retraction reel and at least a portion of the reel shaft are disposed within a sealed housing and a sealed passage defines a pressurized communication pathway between the seal arrangement of the plurality of pressurized tubes and the sealed housing.
13. A telescoping mast system comprising:
a frame;
a plurality of interconnected tube sections including at least a base tube, an intermediate tube and a top tube, each tube section comprises a substantially hollow body;

a retraction controller mechanism including a retraction reel, a reel shaft, a motor and a resilient member extending therefrom and in communication with the plurality of interconnected tube sections, wherein the retraction reel is located within a sealed housing and the sealed housing comprises at least a reel shaft seal; and

a deployment controller mechanism in communication with the plurality of interconnected tube sections, wherein the deployment controller mechanism comprises a compressor, an exhaust valve and an isolation valve.

14. The telescoping mast system of claim 13, wherein a torsion spring operably interacts with the retraction reel.

15. The telescoping mast system of claim 13 or claim 14, wherein the retraction reel is coupled to the reel shaft.

16. The telescoping mast system of any one of claims 13 to 15, wherein the retraction reel is coupled to the reel shaft, said reel shaft is coupled to a clutch mechanism.

17. The telescoping mast system of any one of claims 13 to 16, wherein the deployment controller mechanism comprises a pressurized storage tank in communication with an isolation valve and the plurality of tube sections.

18. The telescoping mast system of any one of claims 13 to 17, wherein the base tube has a first width, the intermediate tube has a second width, the top tube as a third width, wherein the first width is greater than the second width, the second width is greater than the third width.

19. The telescoping mast system of any one of claims 13 to 18, wherein each tube section comprises a substantially cylindrical shaped body.

20. The telescoping mast system of any one of claim 13 to 19, said top tube being axially aligned with the base tube; said plurality of tube sections including a substantially pressurized seal arrangement.

21. The telescoping mast system of any one of claim 13 to 20, said resilient member extending from the retraction reel and in communication with the top tube: said retraction reel axially engaged to the reel shaft.

22. The telescoping mast system of any one of claims 13 to 21, wherein the retraction controller mechanism includes a means to induce rigidity of the resilient member.
23. The telescoping mast system of claim 22, wherein the means to induce rigidity of the resilient member includes a clutch mechanism in axial alignment with said reel shaft and said motor wherein said clutch mechanism allows for the at least one of a torque rotation and free rotation of said retraction reel.
24. The telescoping mast system of any one of claims 13 to 23, further including a controller box, said controller box provides electronic control to the retraction mechanism and deployment mechanism.
25. The telescoping mast system of any one of claims 13 to 24, wherein a sealed conduit and a sealed housing are provided for communication between the plurality of tube sections and the retraction mechanism.
26. A method of telescoping a mast system, the method comprising:
providing a plurality of tube sections in a retracted position;
introducing a pressurized gas from a deployment controller mechanism in communication with the plurality of tube sections;
deploying the plurality of tubes to a desired extended position,
providing a resilient member from a top tube to a retraction controller mechanism;
attracting the resilient member to the retraction controller mechanism;
directing the plurality of tubes to a desired retracted position, and
opening an exhaust valve in communication with the plurality of tubes to allow for a discharge of pressure during the attracting the resilient member.
27. The method of telescoping a mast system of claim 26, wherein pressurized gas is introduced by a localized storage tank in operable communication with the plurality of tubes.

FIG. 1

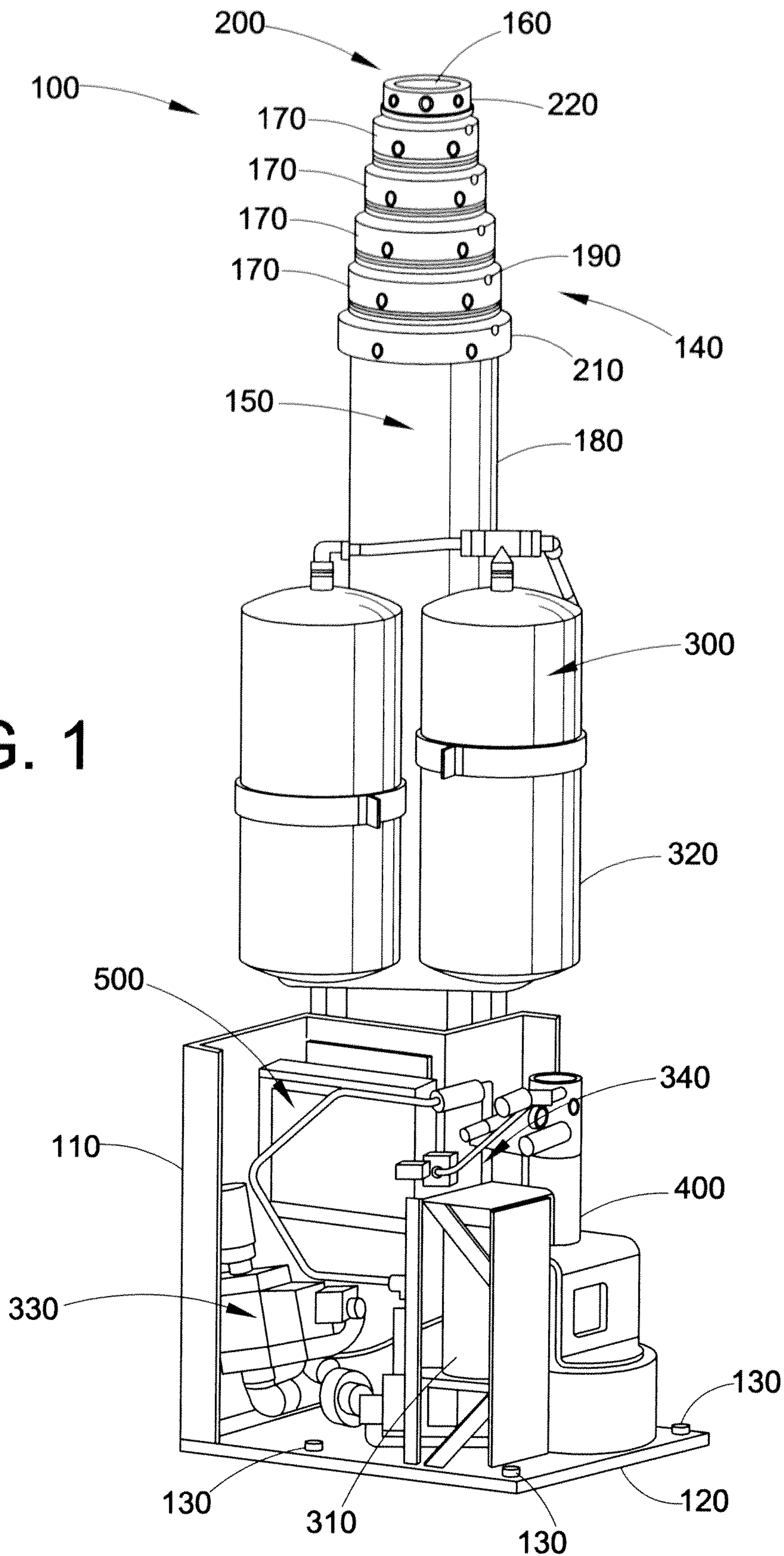

FIG. 3

