

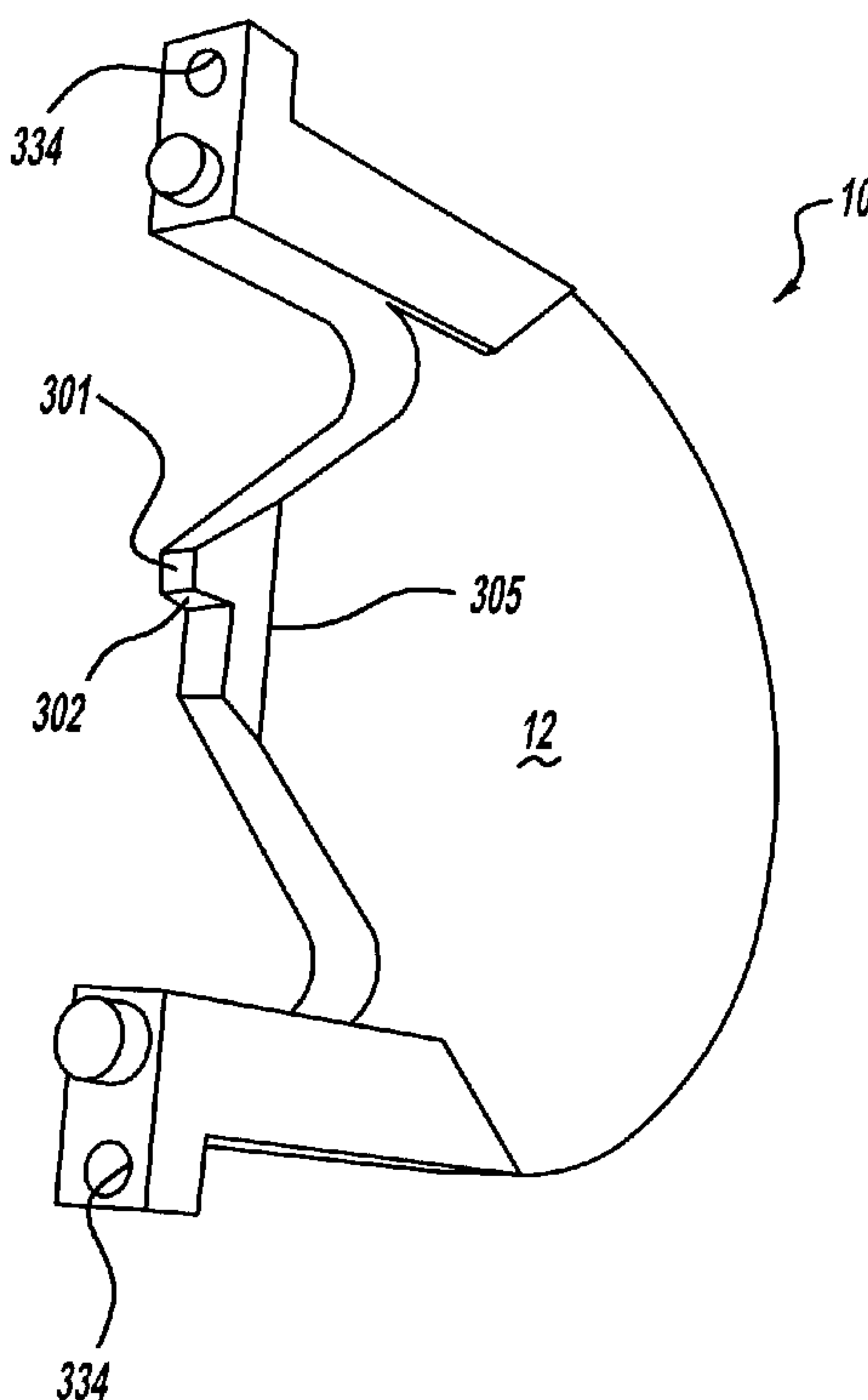

(22) Date de dépôt/Filing Date: 2009/04/30
(41) Mise à la disp. pub./Open to Public Insp.: 2009/11/01
(30) Priorité/Priority: 2008/05/01 (US61/126,116)

(51) Cl.Int./Int.Cl. *G02B 27/09* (2006.01),
B60Q 1/06 (2006.01)
(71) Demandeur/Applicant:
MAGNA INTERNATIONAL INC., CA
(72) Inventeur/Inventor:
WOODWARD, RONALD O., US
(74) Agent: BRANDT, KERSTIN B.

(54) Titre : DISPOSITIF OPTIQUE EN D A COUPURE DE POINT CHAUD
(54) Title: HOTSPOT CUTOFF D-OPTIC



(57) **Abrégé/Abstract:**

The present invention is an optic used for producing a desired beam pattern having a body portion having a height and a thickness, and at least one sidewall profile, as well as an input port for receiving light from a light source. The optic of the present invention also includes an output surface formed as part of the body portion on the opposite side of the body portion in relation to the input port, at least one leg portion formed as part of the body portion, and at least one alignment feature formed as part of the at least one leg portion, the at least one alignment feature for controlling the alignment of the optic in relation to the light source.

ABSTRACT

The present invention is an optic used for producing a desired beam pattern
5 having a body portion having a height and a thickness, and at least one sidewall
profile, as well as an input port for receiving light from a light source. The optic of the
present invention also includes an output surface formed as part of the body portion
on the opposite side of the body portion in relation to the input port, at least one leg
portion formed as part of the body portion, and at least one alignment feature formed
10 as part of the at least one leg portion, the at least one alignment feature for
controlling the alignment of the optic in relation to the light source.

HOTSPOT CUTOFF D-OPTIC

FIELD OF THE INVENTION

[0001] The present invention relates to an optic used for producing various
5 beam patterns, such as spread beam patterns, hot spot beam patterns, bending
beam patterns, and combinations thereof.

BACKGROUND OF THE INVENTION

[0002] Current light emitting diode (LED) headlamp designs use a
10 projector system to build the high beam hotspot and imaged masks or source
shapes to generate the sharp cutoff in the low beam pattern. This is a costly,
complex and inefficient solution. Previously we invented an optical element that
could produce a wide beam pattern with tall thin optical elements eliminating much of
the complexities and providing improved efficiency over projector systems.
15 However, the pattern produced was very wide and smooth, providing insufficient
intensity in the center of the pattern; therefore, a projector system was still needed to
produce the high beam and low beam hotspots required to achieve a complete beam
pattern.

[0003] Additionally, when a light source is used to provide light for an input
20 surface, the light from the light source often does not provide light for the entire input
surface area. This will often result in a "banding effect," where waves of alternating
light and dark area will be seen in the resulting beam pattern.

[0004] Another difficulty which arises in the production of optics is that
there are certain requirements which must be met with regard to glare from a
25 headlamp directed towards a driver's eyes when two vehicles are approaching each
other from opposite directions. Headlamps need to accommodate for this glare, and
must not produce light in certain glare test points which represent the oncoming
driver's eye location.

[0005] Accordingly, there exists a need for a lighting device which
30 overcomes the aforementioned problems.

SUMMARY OF THE INVENTION

[0006] The present invention solves the intensity and cutoff problems of
typical optics by using an optic with a tall, thin profile having specific characteristics

that allow the production of higher maximum intensities required for a high beam pattern. The optic of the present invention also provides sufficiently sharp horizontal gradients needed for a low beam pattern, which is required for good photometric and on road performance. The present invention also seeks to develop tall, thin optics
5 that can efficiently deliver high intensity light, and can also be used to form the required shapes in the headlamp beam pattern.

[0007] The present invention is an optic used for producing a desired beam pattern with a body portion having a height and a thickness, and at least one sidewall profile, as well as an input port for receiving light from a light source. The
10 optic of the present invention also includes an output surface formed as part of the body portion on the opposite side of the body portion in relation to the input port, at least one leg portion formed as part of the body portion, and at least one alignment feature formed as part of the at least one leg portion, the at least one alignment feature for controlling the alignment of the optic in relation to the light source.

[0008] A first embodiment of the present invention includes a curved
15 output surface, and specially shaped top, bottom, and side walls. A series of sloped, planar walls near the input port coupled with the thin crosssection combine to create a smooth, wide horizontal light pattern having a sharp, controllable gradient in the vertical direction, and a smooth exponential pattern fade out below horizontal to the
20 deep foreground. This optic is used to create fog lamp beams, or the wide spread portion of headlamp beam patterns. If needed, the smoothness of the pattern can be improved by applying a horizontal wave function to the output surface. A slight variation of this optic which is designed to produce an inverted cutoff pattern is combined with the first optic to provide a high beam spread pattern.

[0009] A second embodiment of the present invention is an optic which is
25 thicker and taller, having different and specially shaped top, bottom, and side walls. These changes allow a single LED to produce a much higher (aproximatly 10 times higher) maximum intensity compared to the optic described in the first embodiment. The optic of this embodiment provides the high intensity portion of a high beam
30 headlamp pattern.

[0010] A third embodiment of the present invnetion is an optic that has features similar to those of the first and second optics combined, but without the small, planar surfaces near the input port. These features create a high intensity pattern, having a horizontal cutoff with a high vertical gradient and smooth

foreground blending. This optic can be used to provide a portion of the lowbeam hotspot or suplimental lighting that improves ilumination around curves.

[0011] A fourth embodiment of the present invention is an optic which combines the features of the third embodiment with additional features that allow it to produce a high intensity pattern that fills only one quadrent (when the beam is projected onto a graph) by producing relativly sharp gradients in both the horizontal and vertical directions, and is combined with the third optic to create an improved low beam hotspot pattern.

[0012] A fith embodiment of the present invention is an optic which combines features of the third embodiment with different features to produce a beam pattern that is similar to that produced by the combination of the third and fourth embodiments, having both a horizontal spread with vertical cutoff and a stepped pattern with a horizontal cutoff.

[0013] A sixth embodiment of the present invention is an optic that combines features of the fifth optic with additional features, making it possible to create a complete low beam pattern with a single optic. In all cases, multiple devices will be required until the optical output of a single LED is sufficient to produce a low beam pattern of sufficient intensity.

[0014] Further areas of applicability of the present invention will become apparent from the detailed description provided hereinafter. It should be understood that the detailed description and specific examples, while indicating the preferred embodiment of the invention, are intended for purposes of illustration only and are not intended to limit the scope of the invention.

BRIEF DESCRIPTION OF THE DRAWINGS

[0015] The present invention will become more fully understood from the detailed description and the accompanying drawings, wherein:

[0016] Figure 1 is a first perspective view of an optic, according to a first embodiment of the present invention;

[0017] Figure 2 is a second perspective view of an optic, according to a first embodiment of the present invention;

[0018] Figure 3A is a sectional side view taken along lines 3A-3A of Figure 2;

- [0019]** Figure 3B is a top sectional view taken along lines 3B-3B of Figure 2;
- [0020]** Figure 3C is a sectional front view taken along lines 3C-3C of Figure 2;
- 5 **[0021]** Figure 4 is a graph depicting a vertical cross-section of the beam pattern produced by an optic according to a first embodiment of the present invention;
- [0022]** Figure 5 is a beam pattern produced by an optic, according to a first embodiment of the present invention;
- 10 **[0023]** Figure 6A is a first perspective view of an optic, according to a second embodiment of the present invention;
- [0024]** Figure 6B is a second perspective view of an optic, according to a second embodiment of the present invention;
- [0025]** Figure 7A is a sectional side view taken along lines 7A-7A of Figure 15 6B;
- [0026]** Figure 7B is a sectional top view taken along lines 7B-7B of Figure 6B;
- [0027]** Figure 8 is a projected beam pattern produced by an optic, according to a second embodiment of the present invention;
- 20 **[0028]** Figure 9A is a first perspective view of an optic, according to a third embodiment of the present invention;
- [0029]** Figure 9B is a second perspective view of an optic, according to a third embodiment of the present invention;
- [0030]** Figure 10A is a sectional side view taken along lines 10A-10A of 25 Figure 9B;
- [0031]** Figure 10B is a sectional top view taken along lines 10B-10B of Figure 9B;
- [0032]** Figure 10C is a sectional top view taken along lines 10C-10C of Figure 9B;
- 30 **[0033]** Figure 11 is a projected beam pattern produced by an optic, according to a third embodiment of the present invention;
- [0034]** Figure 12 is a low beam pattern divided up into sections used to produce an optic, according to a first embodiment of the present invention;

[0035] Figure 13A is a first perspective view of an optic, according to a fourth embodiment of the present invention;

[0036] Figure 13B is a second perspective view of an optic, according to a fourth embodiment of the present invention;

5 **[0037]** Figure 14A is a sectional side view taken along lines 14A-14A of Figure 13B;

[0038] Figure 14B is a sectional top view taken along lines 14B-14B of Figure 13B;

10 **[0039]** Figure 14C is a sectional front view taken along lines 14C-14C of Figure 13B;

[0040] Figure 15 is a projected beam pattern produced by an optic, according to a fourth embodiment of the present invention;

[0041] Figure 16A is a first perspective view of an optic, according to a fifth embodiment of the present invention;

15 **[0042]** Figure 16B is a second perspective view of an optic, according to a fifth embodiment of the present invention;

[0043] Figure 17A is a sectional side view taken along lines 17A-17A of Figure 16B;

20 **[0044]** Figure 17B is a sectional top view taken along lines 17B-17B of Figure 16B;

[0045] Figure 17C is a sectional front view taken along lines 17C-17C of Figure 16B;

[0046] Figure 18 is a beam pattern produced by an optic, according to a fifth embodiment of the present invention;

25 **[0047]** Figure 19 is a beam pattern produced by the combination of a fourth and fifth embodiment of an optic, according to the present invention;

[0048] Figure 20A is a first perspective view of an optic, according to a sixth embodiment of the present invention;

30 **[0049]** Figure 20B is a second perspective view of an optic, according to a sixth embodiment of the present invention;

[0050] Figure 21A is a sectional side view taken along lines 21A-21A of Figure 20B;

[0051] Figure 21B is a first sectional top view of an optic taken along lines 21B-21B of Figure 20B;

- [0052]** Figure 21C is a second sectional top view taken along lines 21C-21C of Figure 20B;
- [0053]** Figure 21D is a third sectional top view taken along lines 21D-21D of Figure 20B;
- 5 **[0054]** Figure 21E is a sectional front view taken along lines 21E-21E of Figure 20B;
- [0055]** Figure 22 is a beam pattern produced by an optic, according to a sixth embodiment of the present invention;
- [0056]** Figure 23A is a first perspective view of an optic, according to a
10 seventh embodiment of the present invention;
- [0057]** Figure 23B is a second perspective view of an optic, according to a seventh embodiment of the present invention;
- [0058]** Figure 24A is a sectional side view taken along lines 24A-24A of Figure 23B;
- 15 **[0059]** Figure 24B is a first sectional top view taken along lines 24B-24B of Figure 23B;
- [0060]** Figure 24C is a second sectional top view taken along lines 24C-24C of Figure 23B;
- [0061]** Figure 24D is a first sectional front view taken along lines 24D-24D
20 of Figure 23B;
- [0062]** Figure 24E is a second sectional front view taken along lines 24E-24E of Figure 23B;
- [0063]** Figure 25 is a low beam pattern produced by a seventh embodiment of an optic, according to the present invention; and
- 25 **[0064]** Figure 26 is a beam pattern produced by a seventh embodiment of an optic, according to the present invention.

DETAILED DESCRIPTION OF THE PREFERRED EMBODIMENTS

[0065] The following description of the preferred embodiment(s) is merely
30 exemplary in nature and is in no way intended to limit the invention, its application, or uses.

[0066] A first embodiment of an optic according to the present invention is shown in Figures 1, 2, and 3A-3C generally at 10. The optic 10 is configured to be a low beam spread optic. The optic 10 has several new features that improve on and

eliminate the problems with the prior art. Light is received into the optic 10 from a light emitting diode, or LED (not shown) directly coupled to the body 12 of the optic 10 through an input port 301, shortening the light path and improving optical efficiency. The optic 10 also includes a wall 302 and an output surface 304 having a shape so as to focus the light near a notch 303, forming a smooth, blended foreground pattern as shown in Figure 5, and by the vertical cross-section of the pattern, which is shown in Figure 4. The patterns shown in Figure 4 are achieved with greatly reduced sensitivity of the pattern to LED alignment in relation to the optic 10.

10 **[0067]** The horizontal distribution of the output light of the optic 10 is also alternatively controlled by placement of a bend, or "kink" 305 in the side wall, shown generally at 312, between tapered section 314 and essentially straight section 316. When the kink 305 is located near the input port 301, this results in a wider, more distributed, output pattern. When the kink 305 is located near or extended to the
15 output surface 304, a pattern is produced which concentrates more light in the middle of the pattern. The flatness of the top portion of the beam pattern is controlled by changing the profile 307 of the sidewall 312; a thinner section in the center of the profile 307 of the sidewall 312 serves to flatten the outboard ends of the pattern as shown in Figure 5. The graph as shown in Figure 5 includes a horizontal
20 cut off line 320, and a vertical cut off line 322.

[0068] The optic 10 also includes a bottom half 310, and a top half 311. The sidewalls 312 are substantially perpendicular to the output surface 304. The optic 10 also has two leg portions 318 which are attached to two LED alignment features 308,309. The leg portions 318 also include a curved profile section 324,
25 one of which extends into a first lower wall portion 326 and a second lower wall portion 328. The curved profile section 324 helps to improve the strength of the optic 10. Each leg portion 318 also optionally includes an aperture 334, where a fastener (not shown) such as a screw will extend through the aperture 334 to secure the optic 10 to a desired surface. It is also within the scope of the invention that the leg
30 portions 318 may also be clamped down to a desired surface, or the optic 10 may be attached to the desired surface through the use of snap features.

[0069] The optic 10 also includes a height 330 and a thickness 332 which are adjusted to achieve the desired beam pattern. In this embodiment, the height 330 is 40mm, and the thickness 332 is 3.4mm.

[0070] Asymmetric shaping of the sidewall profile 307 can be used to achieve the sloped pattern for ECE beam patterns. The configuration of the optic 10 as shown in Figures 1-3C allows for the addition of the precise LED alignment features 308,309. The LED alignment feature 308 controls height above the LED and, the LED alignment feature 309 controls alignment over the LED. Improved horizontal smoothness is achieved by adding a multi-cycle wave 306, which for example can be in the form of a sinusoidal wave or tangential arcs having various numbers of cycles, to the profile of the output surface 304. A "cycle" is defined as one complete alternating variation in the pattern of the wave. For example, if a sinusoidal wave were used, one cycle would be the completion of 2π radians. The multi-cycle wave 306 will reduce the "banding effect" (alternating bright and dark areas of light) which can occur when using various types of optics. The wave 306 as shown in Figure 3C is a two-cycle wave, and extends only along the top half 311 of the optic 10. Extending the wave 306 from the top to the bottom of the optic 10 reintroduces undesirable light above the horizontal line 320 of the desired beam pattern shown in Figure 5. By eliminating or reducing the waves from the bottom half, generally shown at 310, of the optic 10, any undesirable light above the horizontal line 320 is eliminated. The multi-cycle wave 306 in this embodiment is also a two-cycle wave, meaning that two complete cycles were used to create the wave 306.

[0071] Figures 6A-7B show the configuration for another embodiment of the present invention in the form of a high beam spread optic 910. This embodiment of the optic 910 includes similar features to the optic 10 previously described, but is configured for having a high beam spread pattern, as shown in Figure 8. This embodiment includes a notch 901, which is inverted compared to the notch 303 of the low beam spread optic 10 shown in Figures 1 and 2. This inversion creates a pattern having a cutoff on the bottom of the pattern. This embodiment also includes a first lower wall portion 902 and a second lower wall portion 903, as with the previous embodiment; however, part of the second lower wall portion 903 includes an angled portion 1001, which has been made shallower than the second lower wall portion 328 as compared to the optic 10 in Figures 1 and 2. Introducing the angled portion 1001 into the second lower wall portion 903 redirects light that would have been ineffective below the area indicated generally at 1101 in Figure 8, into the useful pattern as shown in Figure 8. Similar features are optionally employed in the

optic 910 that are shown are part of the low beam optic 10 shown in Figures 1 and 2. A narrower pattern is produced by increasing the thickness 1002 of the optic 910. Improved smoothness is achieved in the optic 910 with a three-cycle output wave 1003, as opposed to a two-cycle output wave. Additionally, because the thickness 1002 of the optic 910 has changed, the position of the kink 1004 has changed as well.

[0072] Figure 9A through 10C show an optic generally at 1410 used for producing a high beam hot spot optic 1410 to achieve higher maximum intensity for use in headlamp high beam applications. Achieving these higher levels of performance requires increasing the size of the optic 1410. The optic height 1401 is increased to 66mm (from an optic height 330 of 40mm described in the optic 10), and the thickness 1402 is increased to 10mm (from a thickness 332 of 3.4mm described in the optic 10). The optic 1410 also includes an input port 1403, similar to the previous embodiments. However the width 1406 of the input port 1403 is decreased to 1.2mm. The width 1406 of the input port 1403 and the thickness 1402 of the output surface 1407 have a significant influence on the pattern of the beam produced. If the width 1406 of the input port 1403 remains constant and the width 1402 of the output surface 1407 is increased, a narrower beam pattern is produced. However, if the width 1402 of the output surface 1407 remains constant and the width 1406 of the input port 1403 is increased, a wider beam pattern is produced. Also, in this embodiment, the curved side profile 1404 of the optic 1410 as shown in Figure 14C is adjusted to produce the highest intensity across the center of the optic 1410. The optic 1410 also has first and second lower wall portions 1408, 1409 which have a hyperbolic profile 1405, which improves the maximum intensity. The resulting output pattern is shown in Figure 11. Maximum intensity produced by this optic 1410 is approximately ten times that produced by the spread optics 10, 910.

[0073] The low beam pattern, shown generally at 1400 in Figure 12, produced by the spread optics 10 is broken up into several parts. The pattern 1400 includes a spread portion 1412, a hot spot portion 1414, and a hot spot cutoff portion 1416. Other embodiments of the invention discussed below act to reduce or modify the hot spot cutoff portion 1416. There is also an area indicated at 1418 which is a test point area 1418. The embodiments discussed below also act to reduce or eliminate light produced in the test point area 1418 such, which is required to be below a maximum value to be used for passenger vehicles.

[0074] Figures 13A through 14C show another embodiment of the present invention in the form of a bending/low beam optic, shown generally at 1700, which uses a similar approach used with regard to the high beam hot spot optic 1410 to achieve the higher intensity necessary for the hot spot used with a low beam. The optic height 1704 of the optic 1700 is larger, once again increased to 66mm, and the thickness 1705 is again increased to be 10mm thick. A notch 1701 and wall 1702 features are used in a similar manner to what was used on the spread optics 10,910. The optic 1700 also includes a first lower wall portion 1706 and a second lower wall portion 1707. The first lower wall portion 1706 is hyperbolic in shape, similar to that in the high beam hotspot optic 1410. The second lower wall portion 1707 is substantially flat, and has no effect on optical performance. The resulting optical pattern is shown in Figure 15. The pattern shown in Figure 18 is also ideal for being used in bending light generation by angling the optic 1700 off-axis to the left and right.

[0075] Figures 16A through 17C show another embodiment of the present invention in the form of the construction of an optic, shown generally at 2000, that also creates a beam pattern as shown in Figure 18. When combined with the previously described optic 1700, the resulting pattern is that of a complete low beam hot spot, shown in Figure 19. The light in the test point area 1418 has been reduced or eliminated. Combining the optic 1700 and the optic 2000 in Figures 13A-14C and 16A-17C incorporates three new features to achieve the desired output. Previously disclosed features of the optic 1700 are employed to create the vertical cutoff, i.e. the notch 2005 and wall 2006. The horizontal cutoff is achieved by applying a second notch 2001 and wall 2002 feature ninety degrees to the first at a different scale in the horizontal direction. A focusing shape 2003 is also applied to the output surface 2004.

[0076] Figure 20A through 21E show the construction of another embodiment of the invention in the form of an optic, shown generally at 2300, that achieves a similar output to that of the combined output of the previous two optics 1700,2000. This performance is achieved by sectioning the optic 2300 along various points of the output surface 2301 into multiple zones. Three zones are used in this embodiment, identified as a first zone 2301, a second 2302, and a third zone 2303, are taken along the sectioned areas of Figure 20B. Each of these three zones 2301,2302,2303 have an independent sidewall 2401, 2403, 2405 and output shapes

2402, 2404, 2406, respectively, as shown in Figures 24B-24E. The resultant output of the optic 2300 is shown in Figure 22. This optic 2300 produces higher optical efficiency.

[0077] Figures 23A through 24E show an optic that can achieve a complete low beam pattern in a single part. The features of this optic 2500 provide both spread and hotspot functions. This is achieved by combining the smaller spread optic 10,910 with the larger hotspot optic 1410,1700. The size split must occur below approximately four degrees from horizontal 2502. The optic 2500 includes a smaller spread section 2503 and a larger hotspot section 2501, the larger hotspot section 2501 has a top portion 2502. There is a horizontal axis 2504 which divides the two sections 2501,2503. The top portion 2502 of the larger hotspot section 2501 descends at an angle 2505 below the horizontal axis 2504. The larger hotspot section 2501 may be broken into multiple sections similar to the optic 2300 previously described, each having an independent sidewall profile, output surface, and size configurations. Figures 25 shows a high beam pattern from the optic 2500, and Figure 26 shows a low beam pattern from the optic 2500.

[0078] The description of the invention is merely exemplary in nature and, thus, variations that do not depart from the essence of the invention are intended to be within the scope of the invention. Such variations are not to be regarded as a departure from the spirit and scope of the invention.

CLAIMS

What is claimed is:

5

1. An optic used for producing a desired beam pattern, comprising:
a body portion having a height and a thickness, and at least one sidewall
profile;

10

a input port for receiving light from a light source;
an output surface formed as part of said body portion on the opposite side of
said body portion in relation to said input port;

15

at least one leg portion formed as part of said body portion; and
at least one alignment feature formed as part of said at least one leg portion,
said at least one alignment feature for controlling the alignment of said optic in
relation to said light source.

20

2. The optic used for producing a desired beam pattern of claim 1, said at least
one alignment feature further comprising a plurality of alignment features, one of said
plurality of alignment features providing control of the distance between said optic
and said light source, and another of said plurality of alignment features used for
controlling the alignment of said optic over said light source.

25

3. The optic used for producing a desired beam pattern of claim 1, further
comprising:
an aperture formed as part of said at least one leg portion; and
a fastener extending through said at least one aperture, thereby securing said
optic to a desired surface.

30

4. An optic used for creating a desired beam pattern, comprising:
a body portion having a height and a thickness, and at least one sidewall
profile;
a input port for receiving light from a light source;

a blending wall operably associated with said input port, said blending wall providing a smooth blended foreground portion of said desired beam pattern irrespective of the placement of said light source in relation to said input port; a first notch operable with said blending wall for providing a cutoff toward the top
5 portion of said desired beam pattern; and

an output surface formed as part of said body portion on the opposite side of said body portion in relation to said input port, that has an optical focus near said notch.

10 5. The optic used for creating a desired beam pattern of claim 4, said optic having a second notch inverted in relation to said first notch for providing a cutoff toward the bottom portion of said desired beam pattern.

15 6. The optic used for creating a desired beam pattern of claim 4, said side wall profile further comprises a narrow portion, said narrow portion providing a flattening out of the outboard ends of said desired beam pattern.

7. The optic used for creating a desired beam pattern of claim 4, further comprising:

20 at least one narrow wall portion formed as part of said body portion, said at least one narrow wall portion having at least one hyperbolic surface, increasing the intensity of said desired beam pattern.

25 8. The optic used for creating a desired beam pattern of claim 4, further comprising a multi-cycle wave formed as a portion of said output surface, said multi-cycle wave increasing the smoothness of said desired beam pattern.

30 9. The optic used for creating a desired beam pattern of claim 4, said at least one sidewall profile further comprising multiple sidewall profiles for shaping said desired beam pattern.

10. The optic used for creating a desired beam pattern of claim 9, wherein said multiple sidewall profiles are asymmetric with respect to one another.

11. The optic used for creating a desired beam pattern of claim 4, further comprising:

a second notch; and

5 a side wall profile, said second notch and said side wall profile rotated ninety degrees in relation to said at least one side wall profile and a horizontal output profile, thereby providing a focus at the location of said second notch.

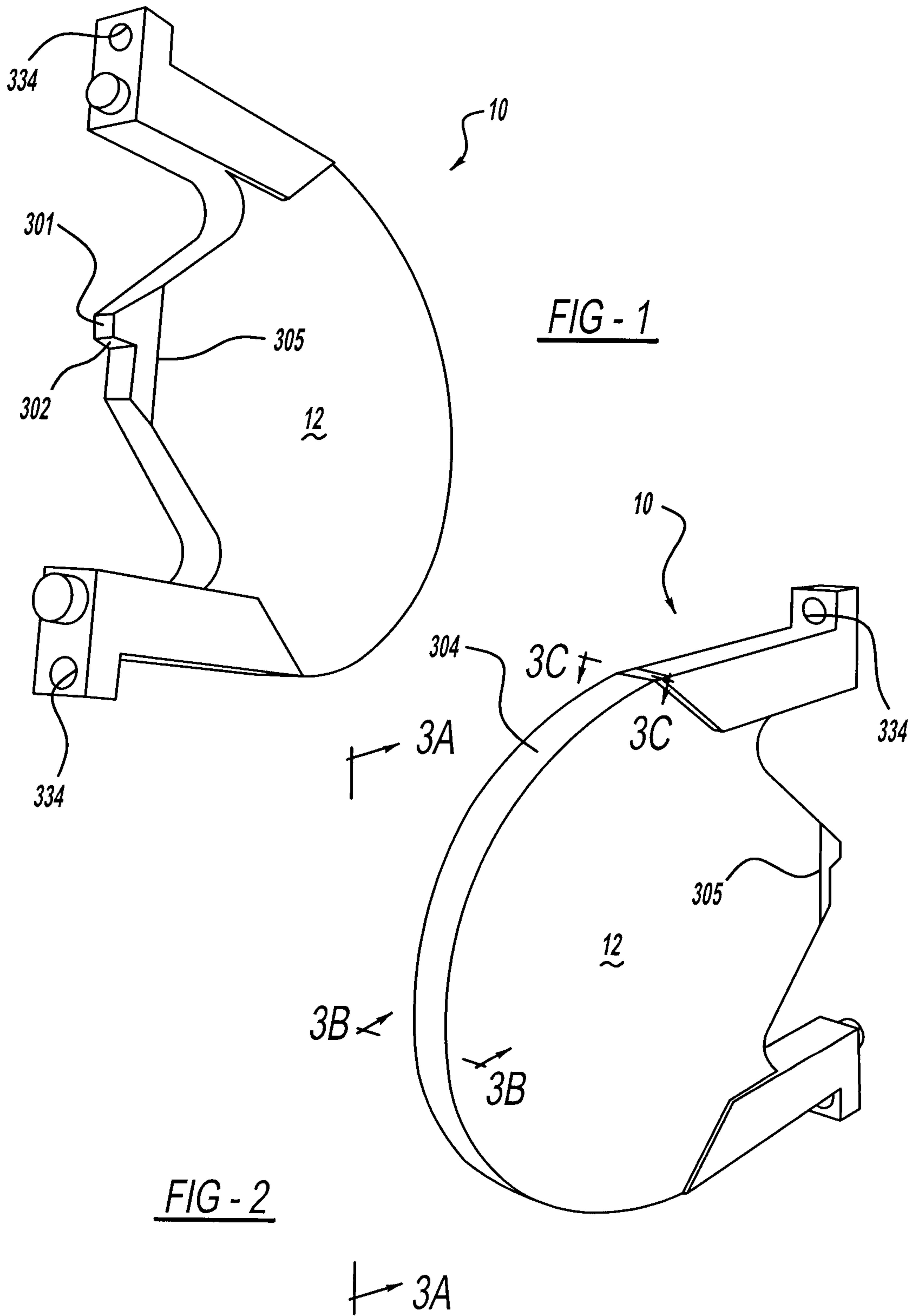

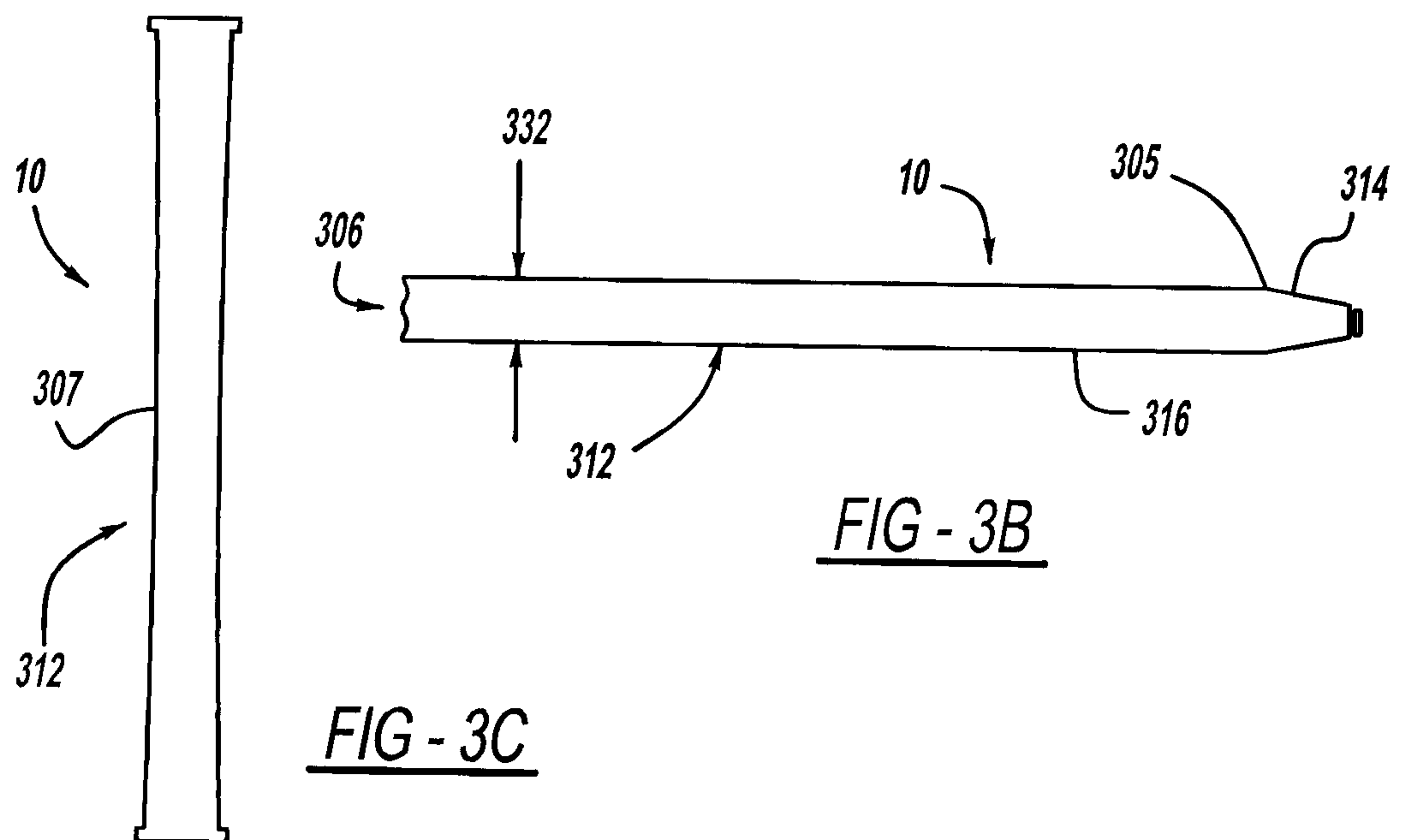
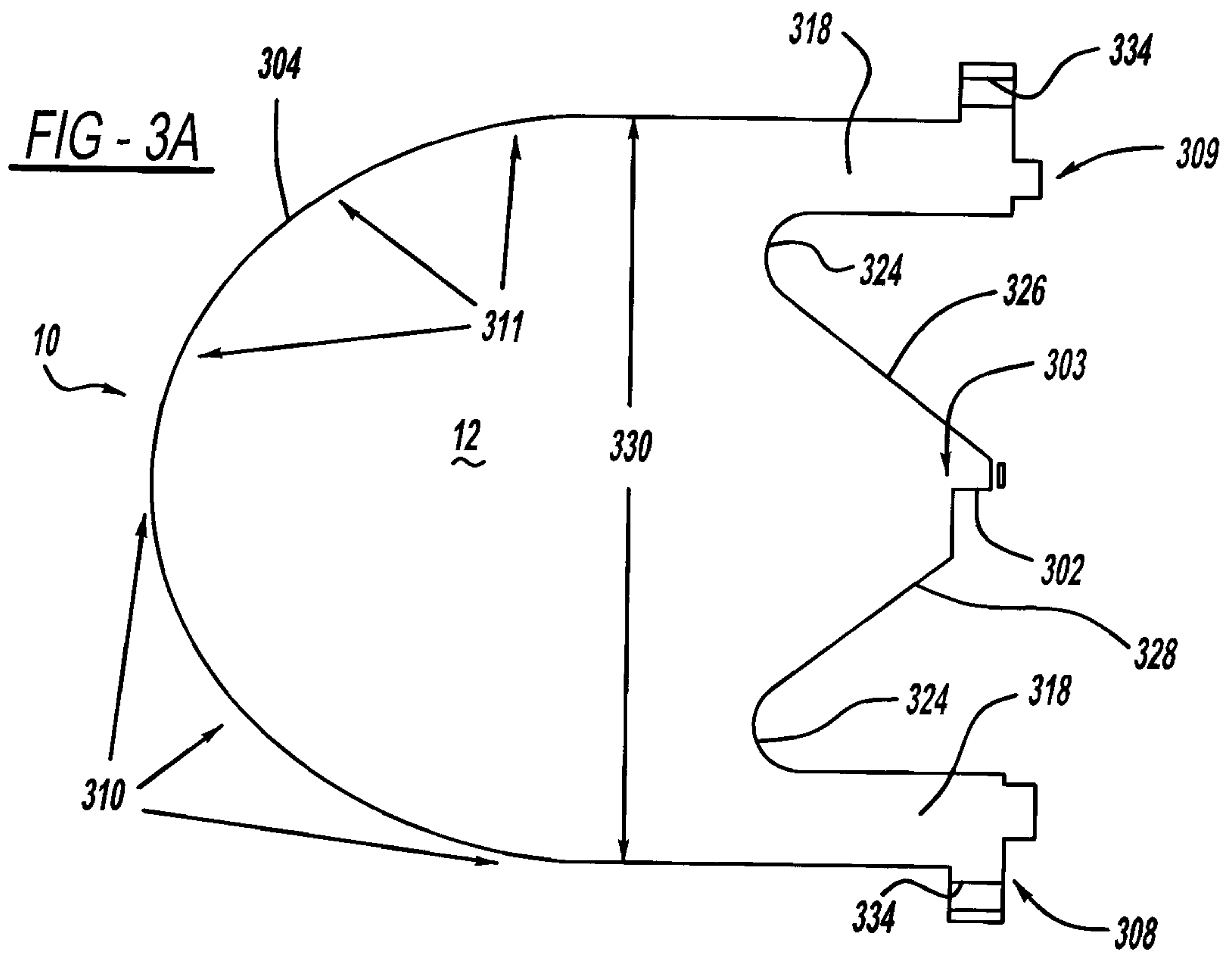

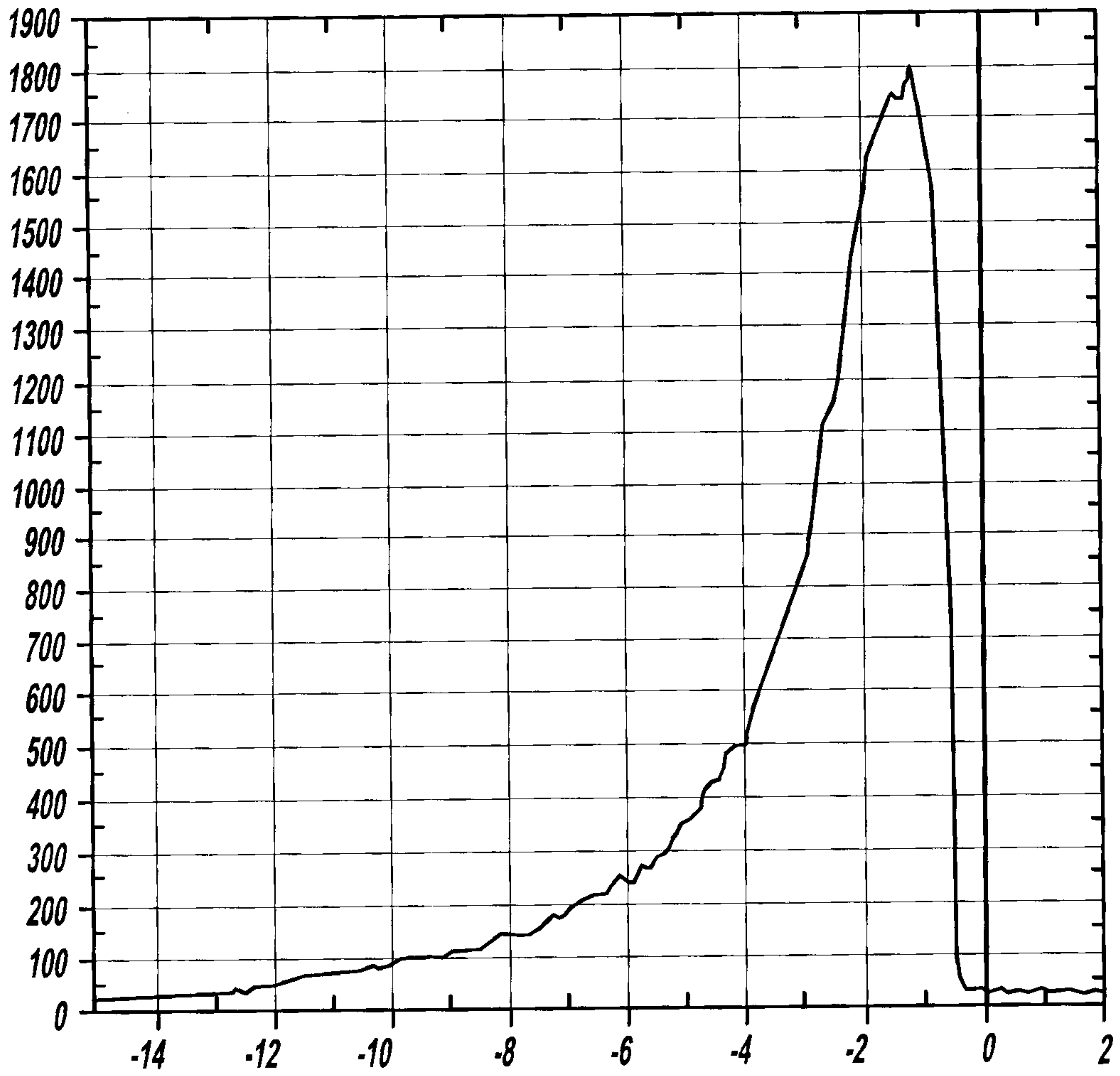

FIG - 4

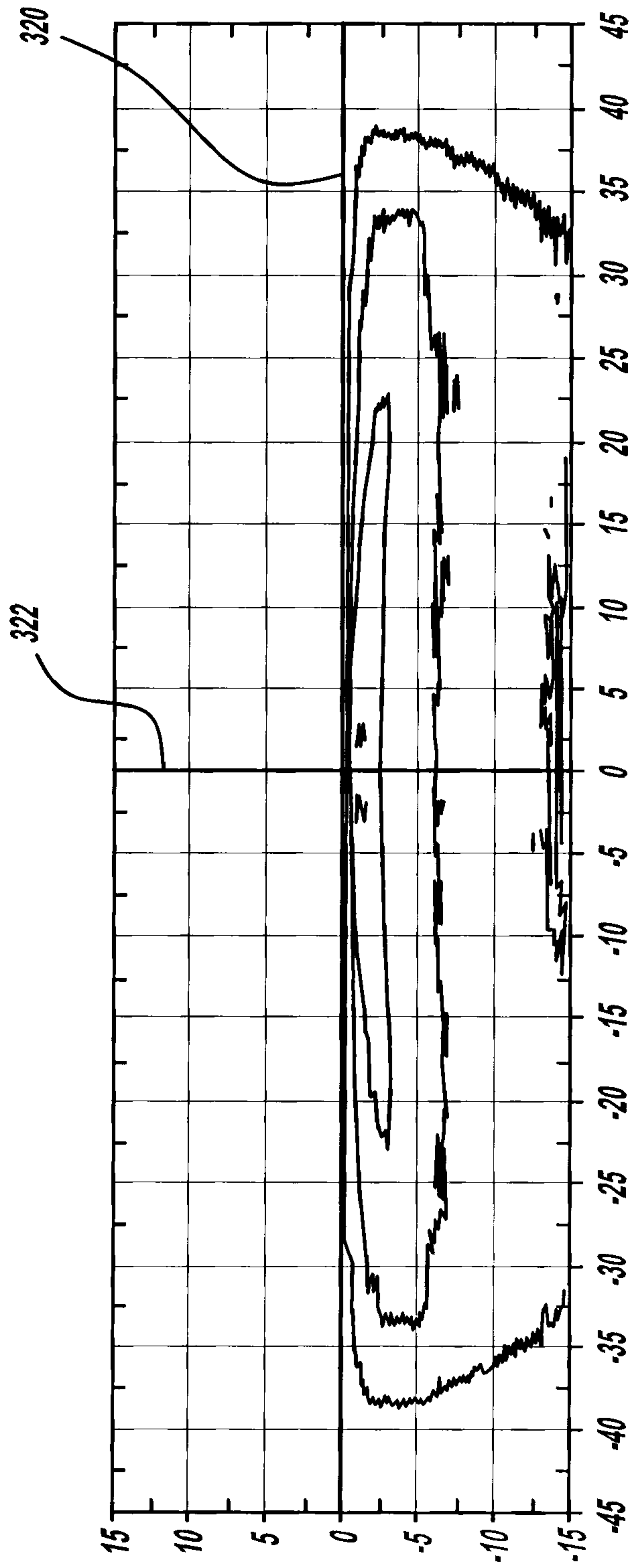
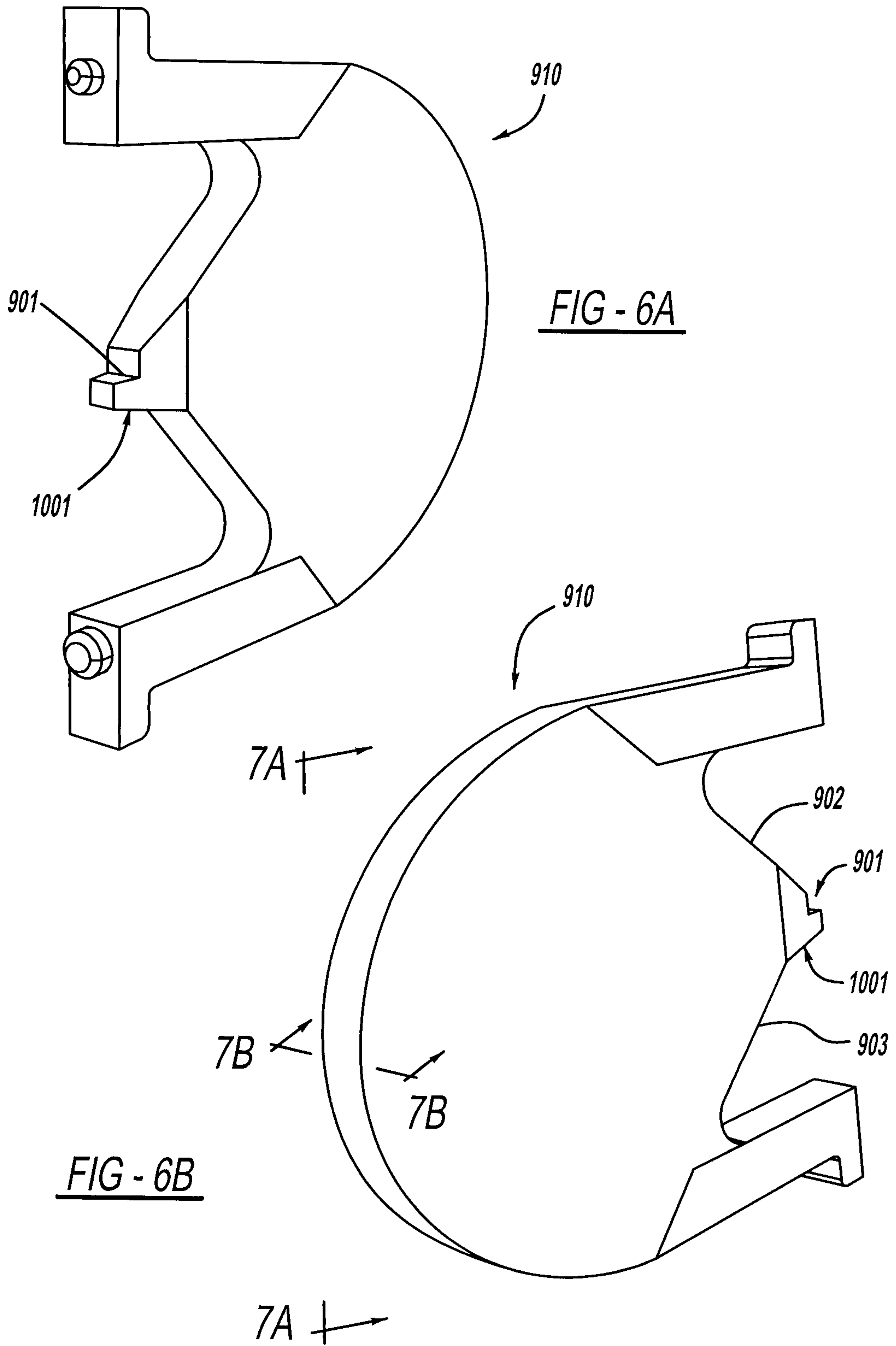

FIG - 5



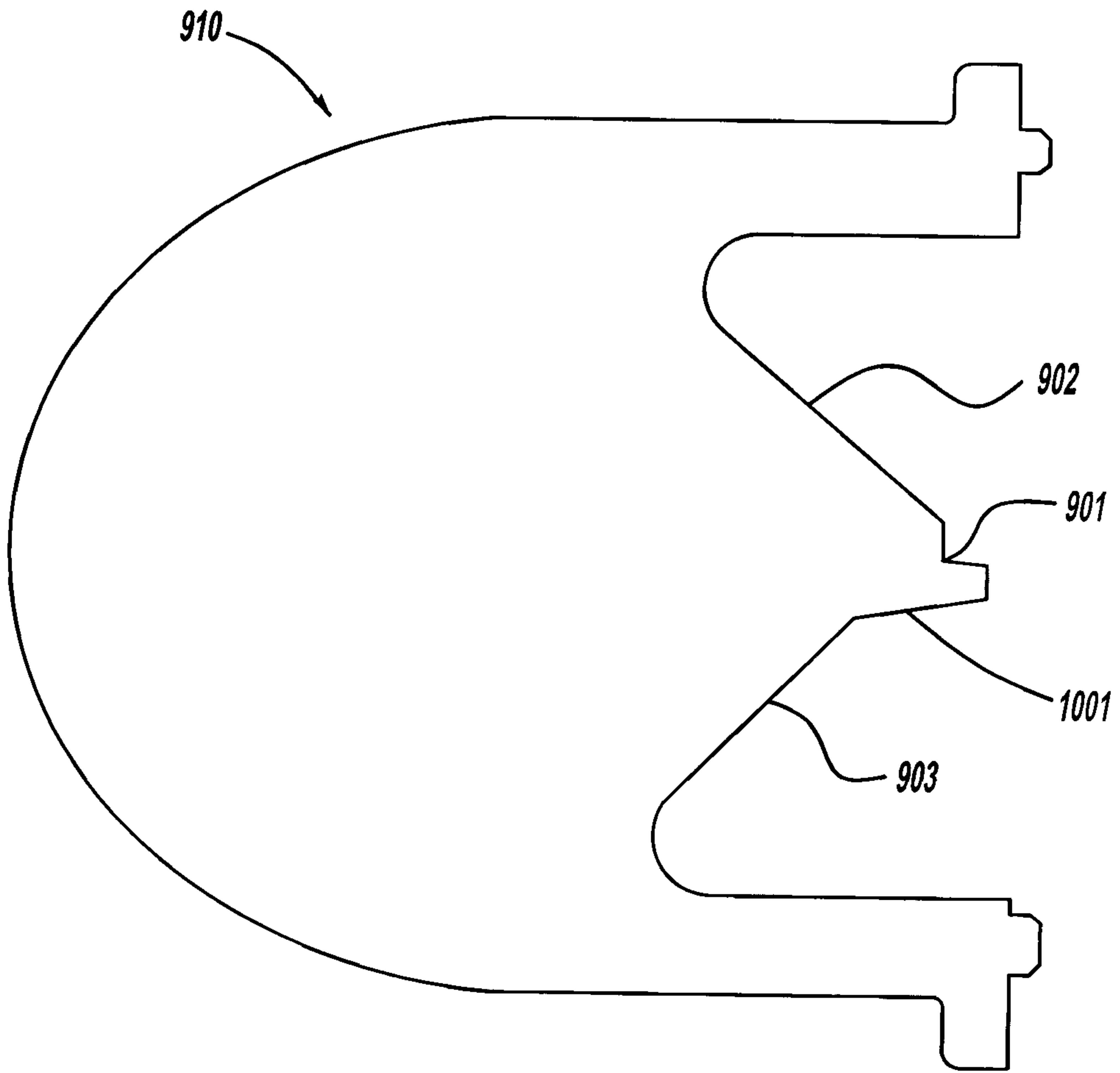

FIG - 7A

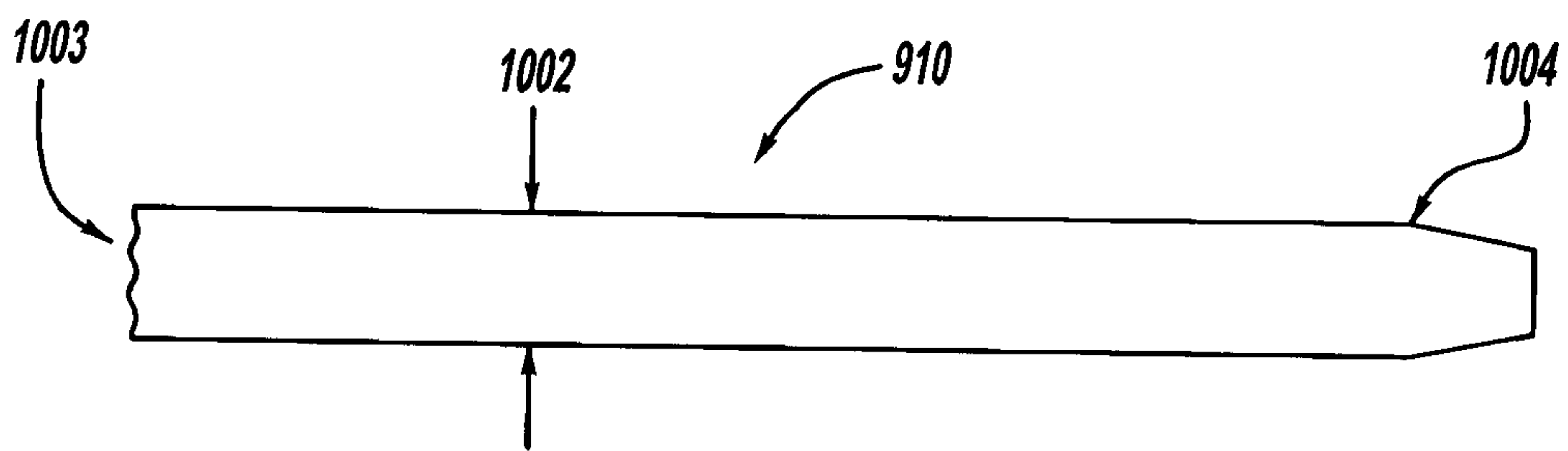
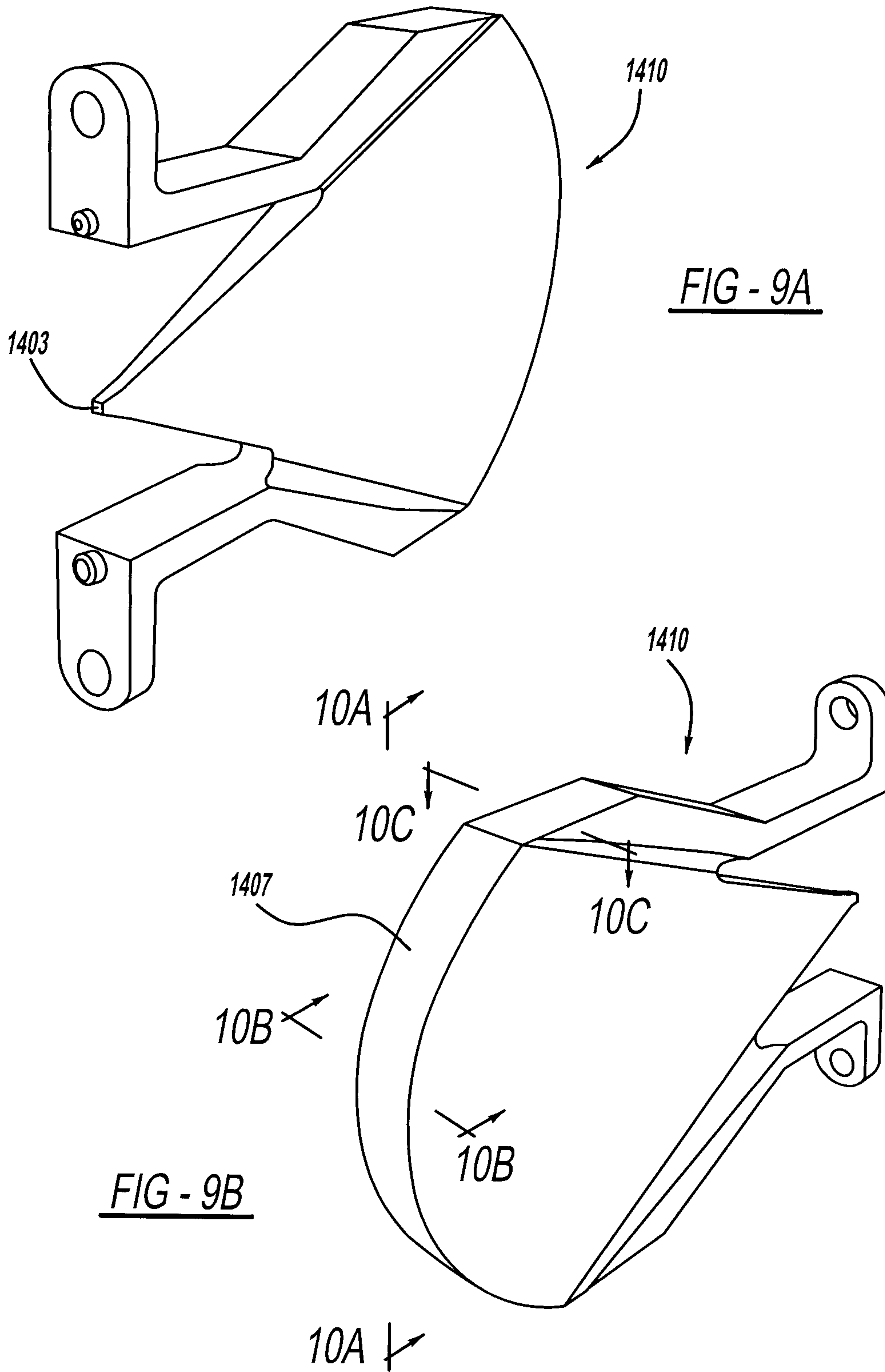

FIG - 7B



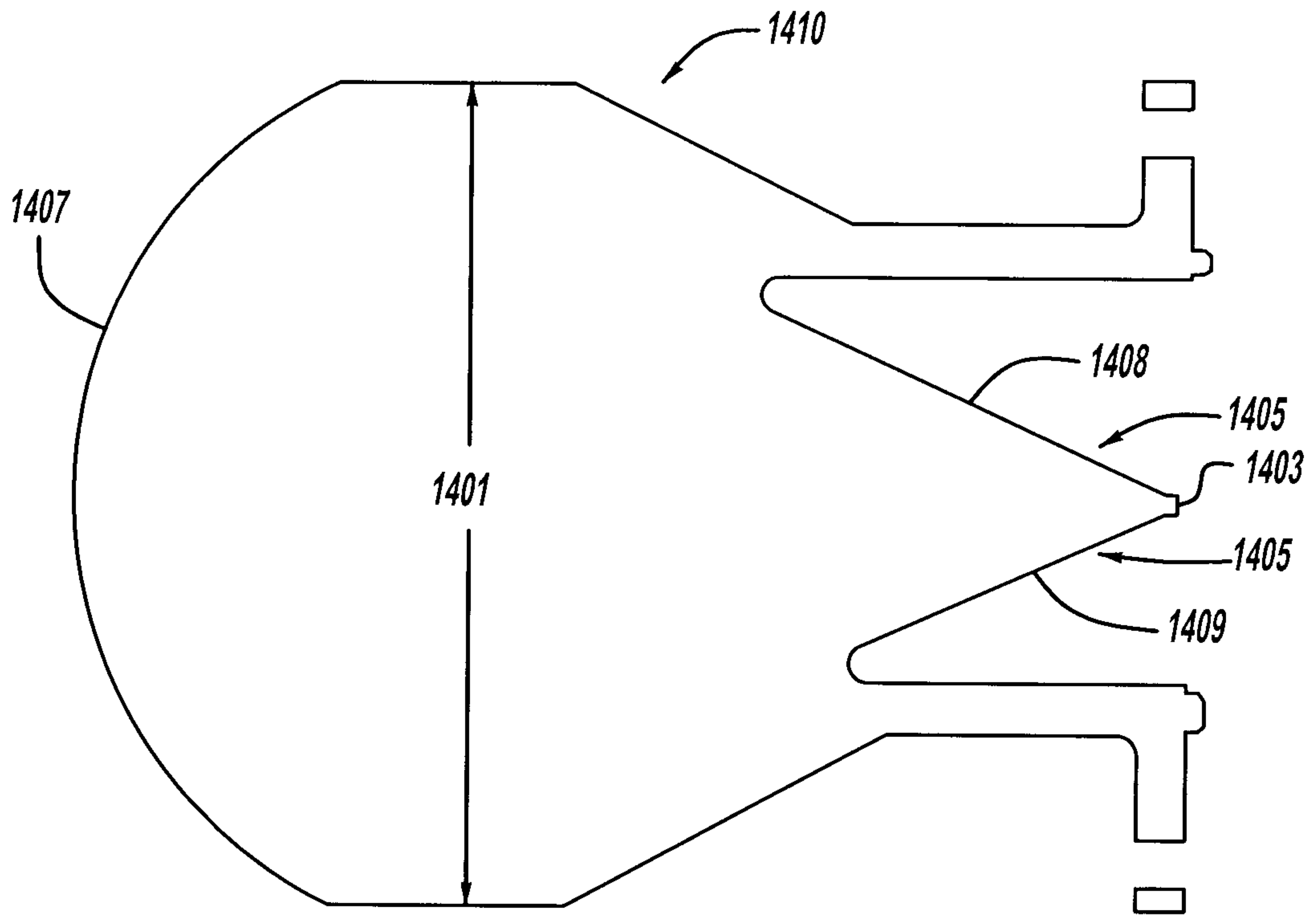

FIG - 10A

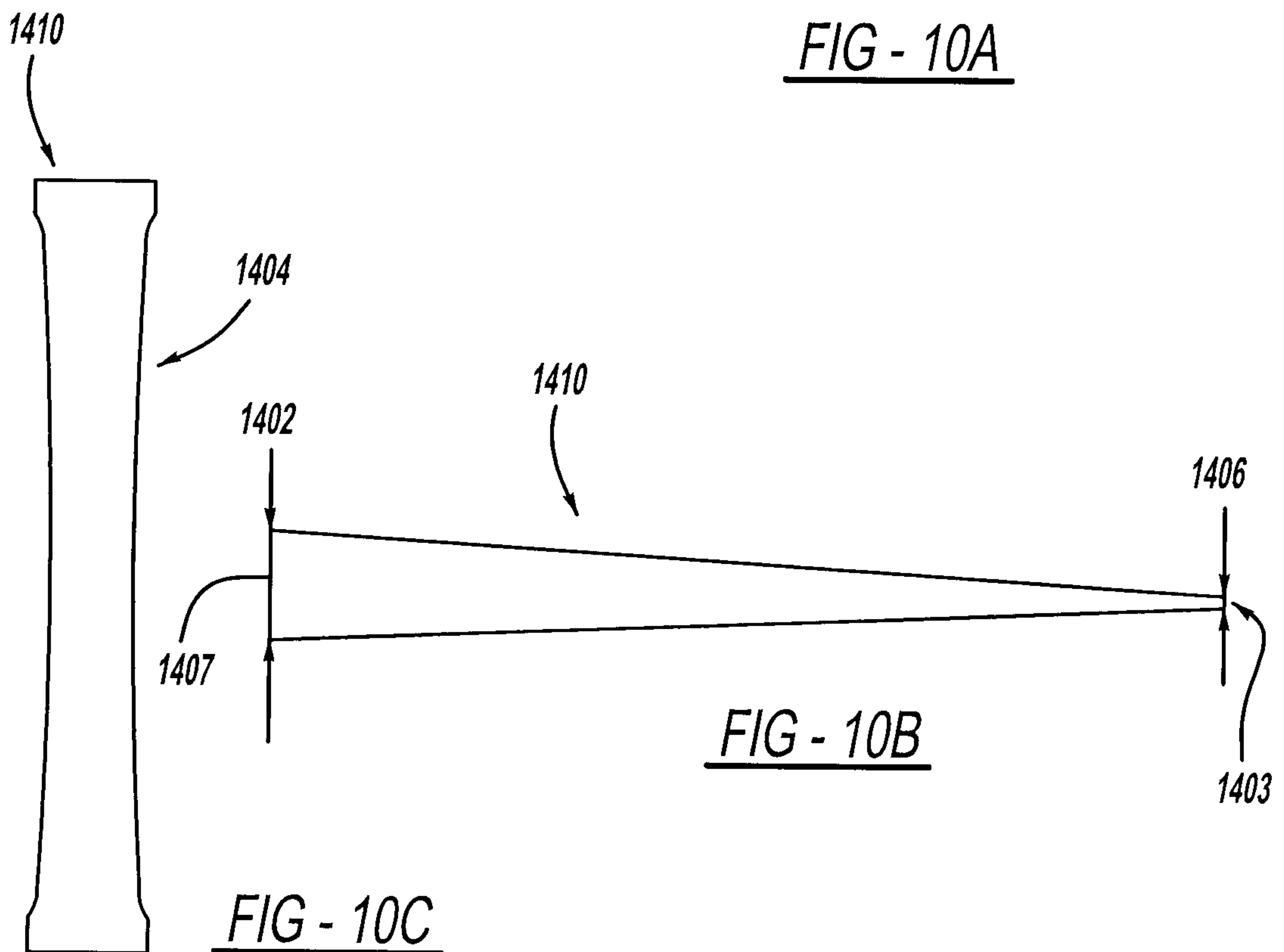

FIG - 10B

FIG - 10C

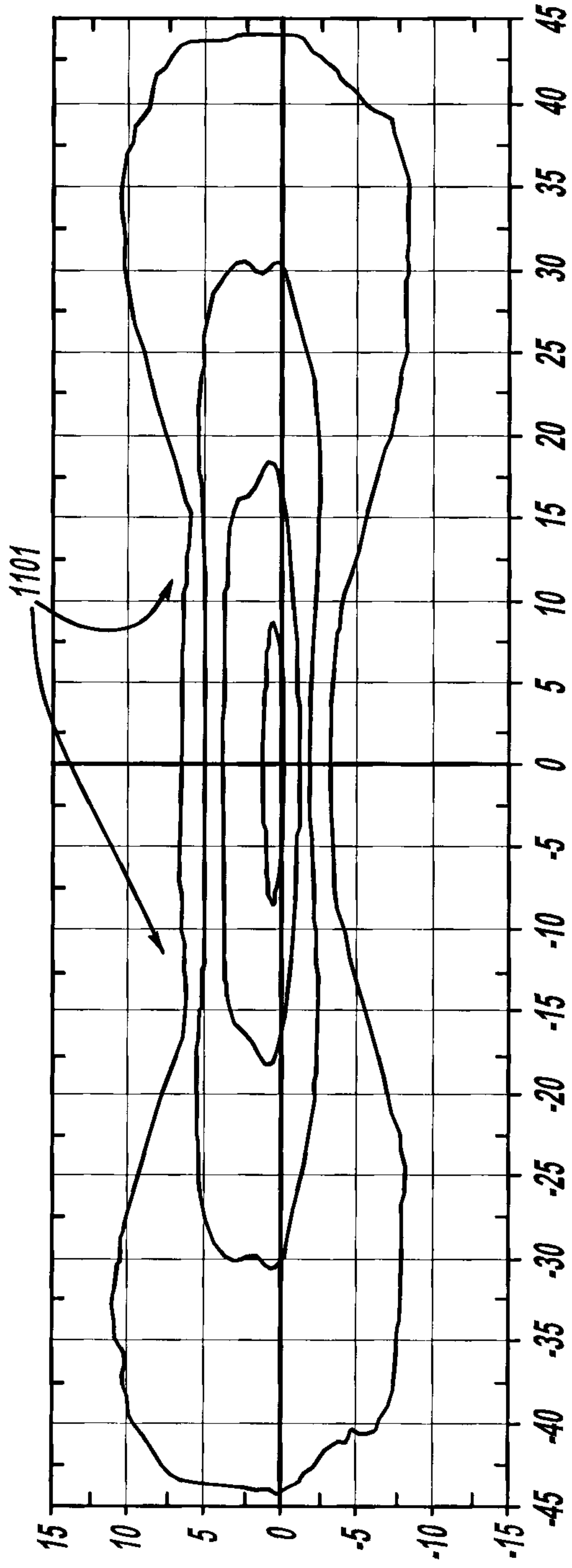

FIG - 8

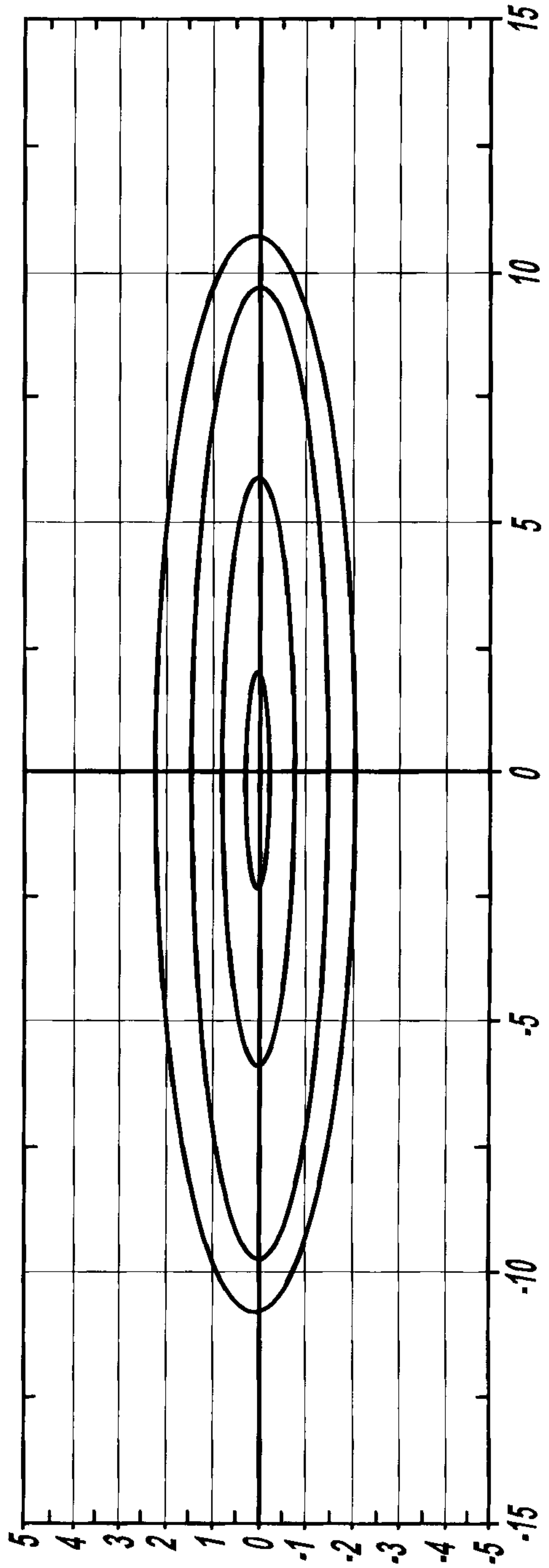

FIG - 11

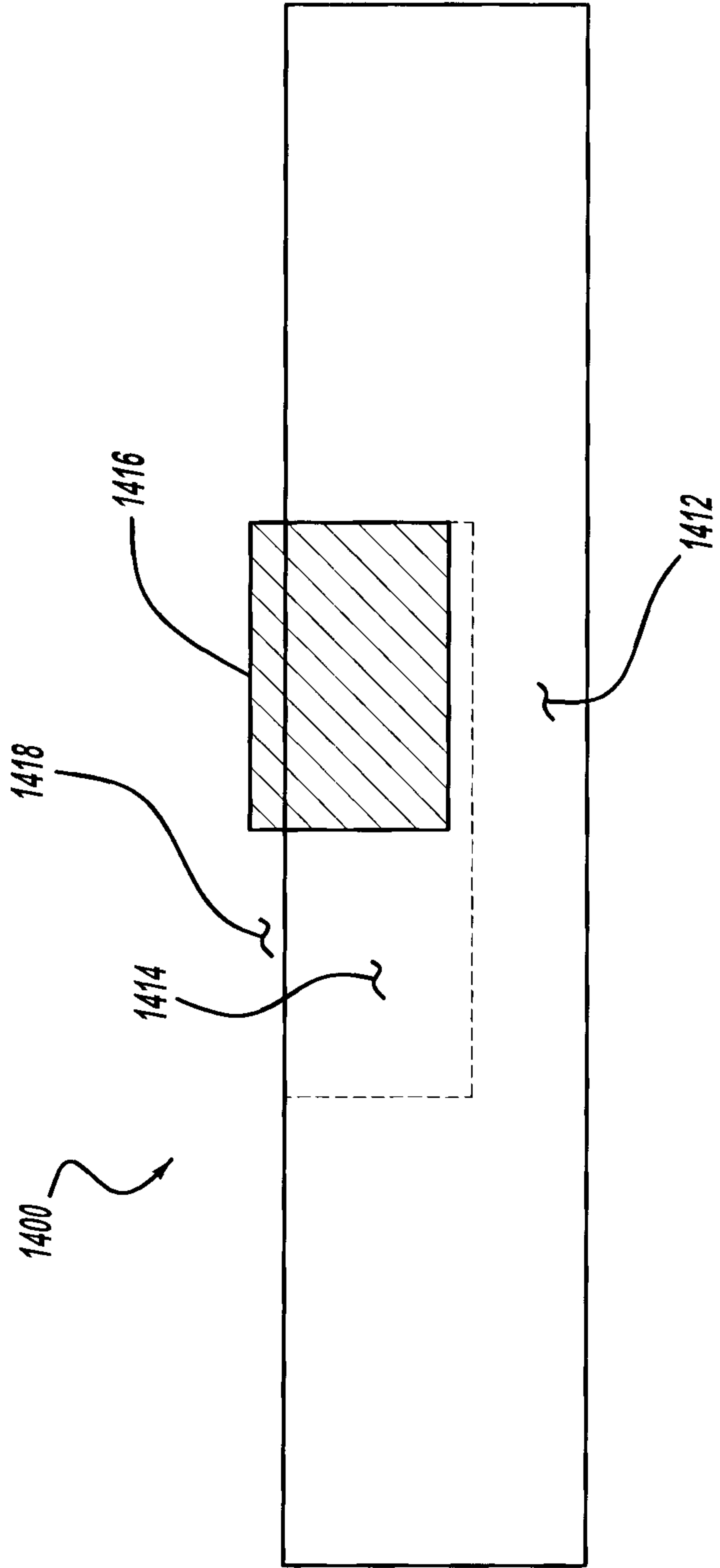
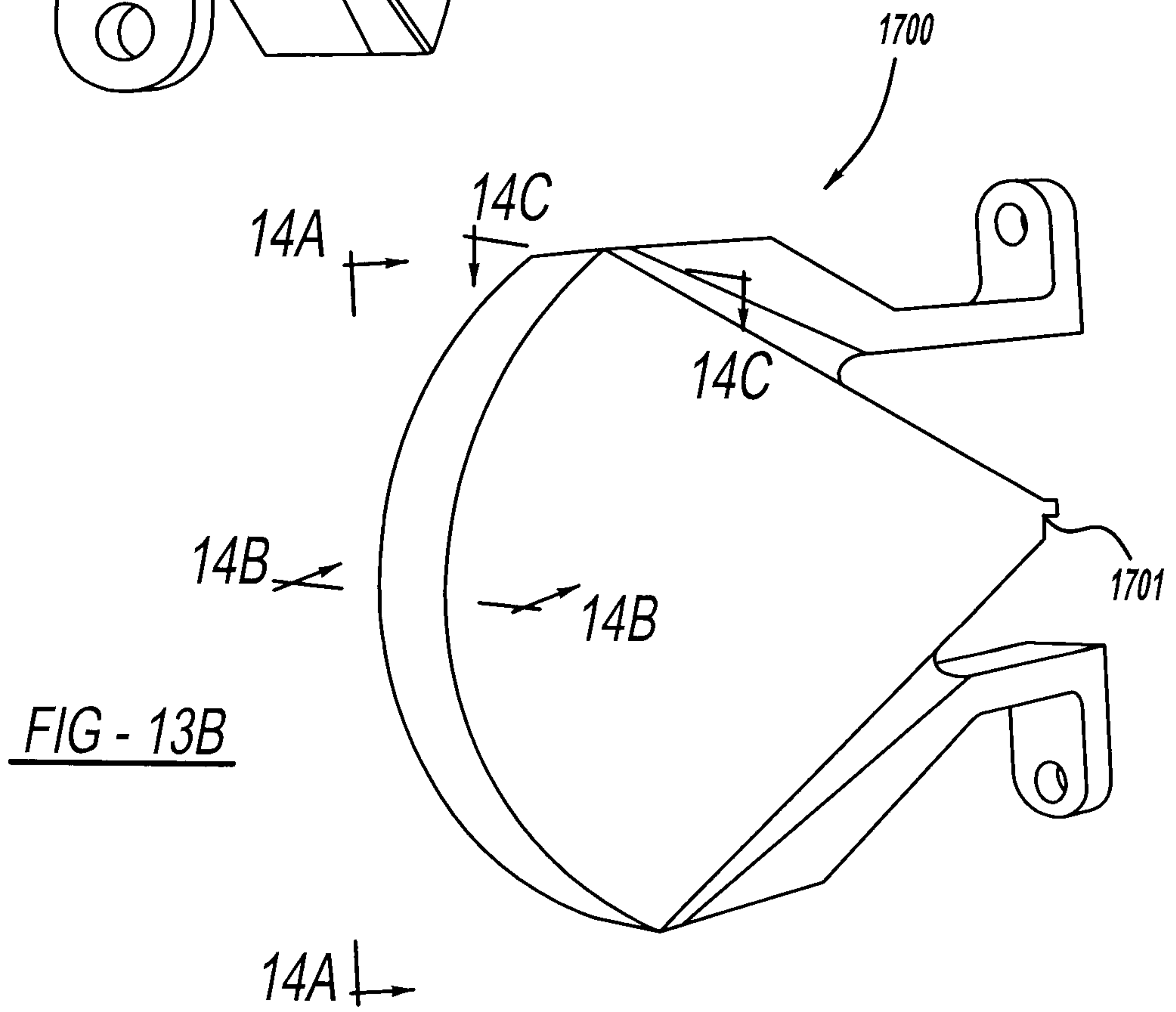
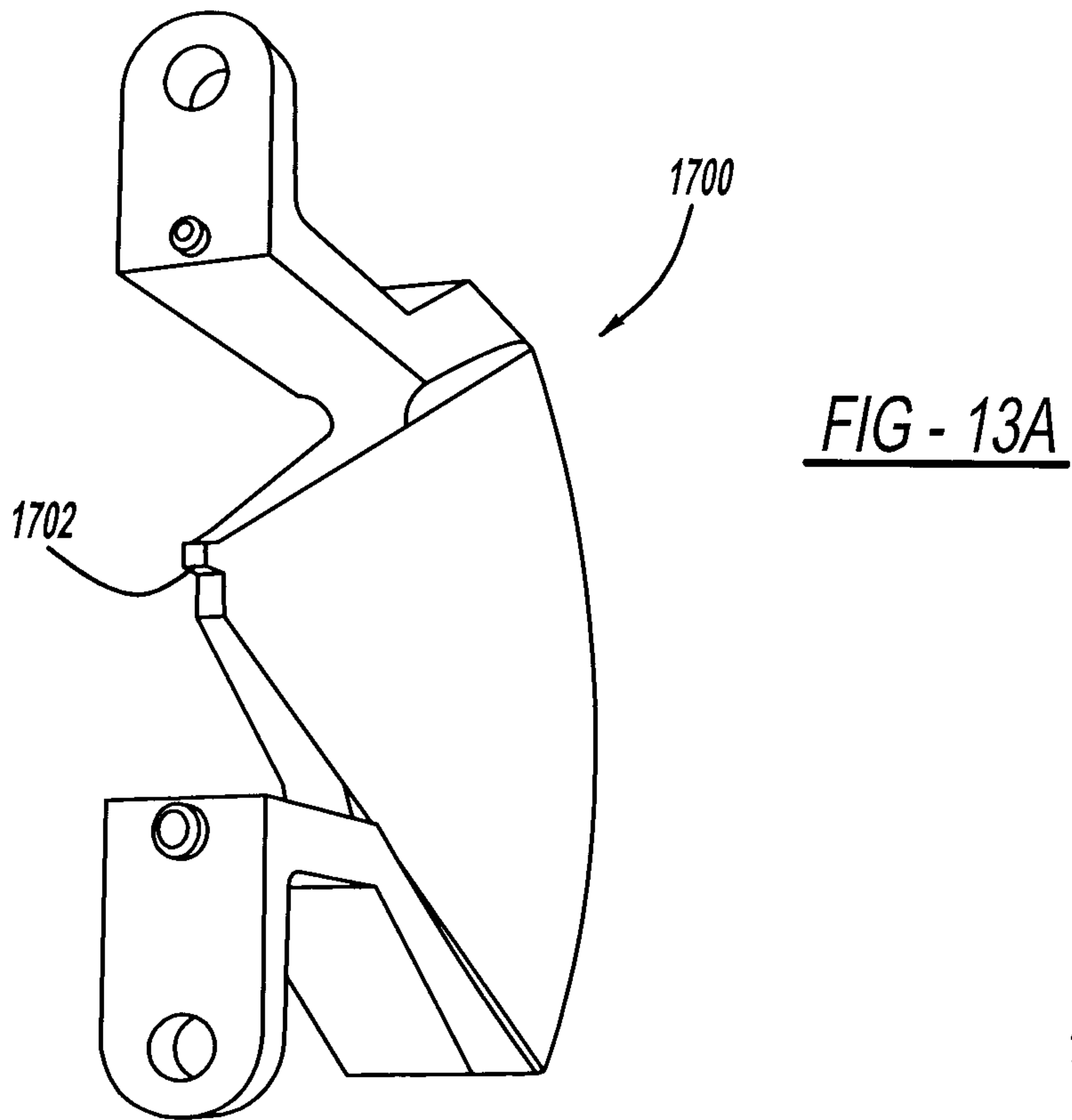

FIG - 12



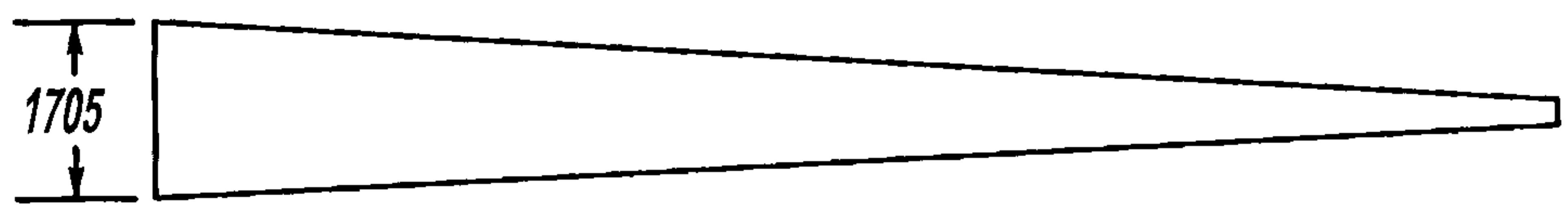
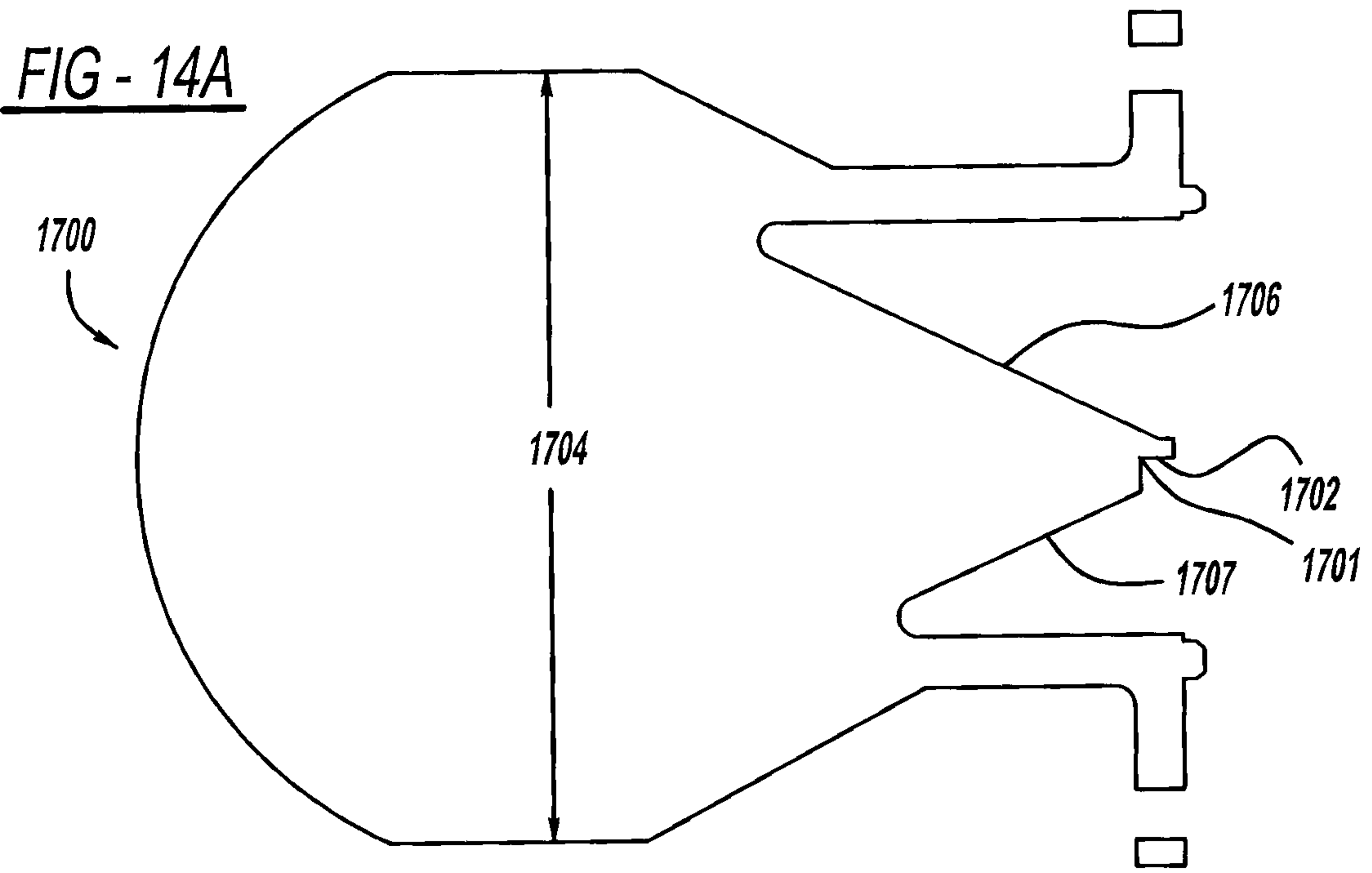
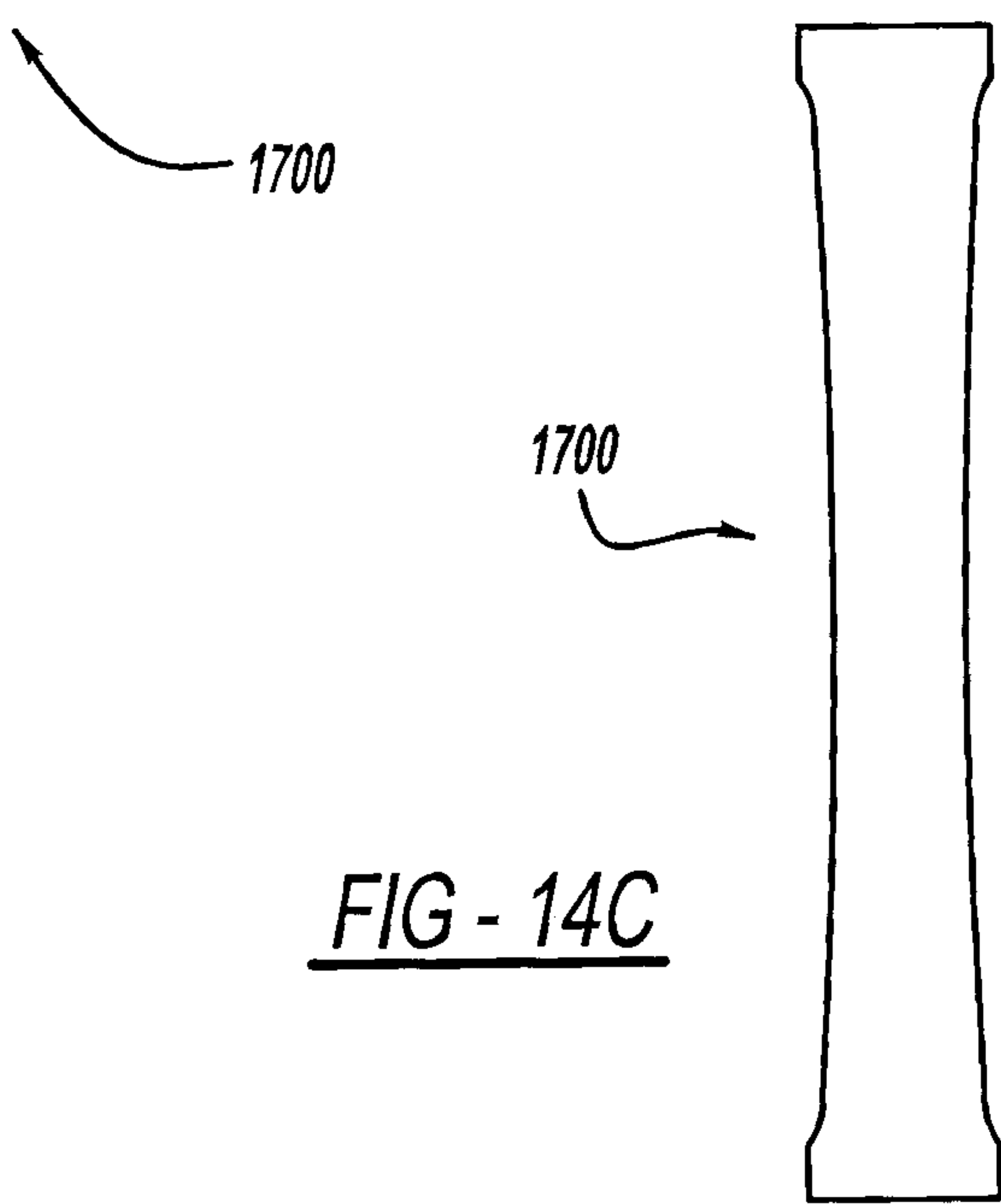

FIG - 14B



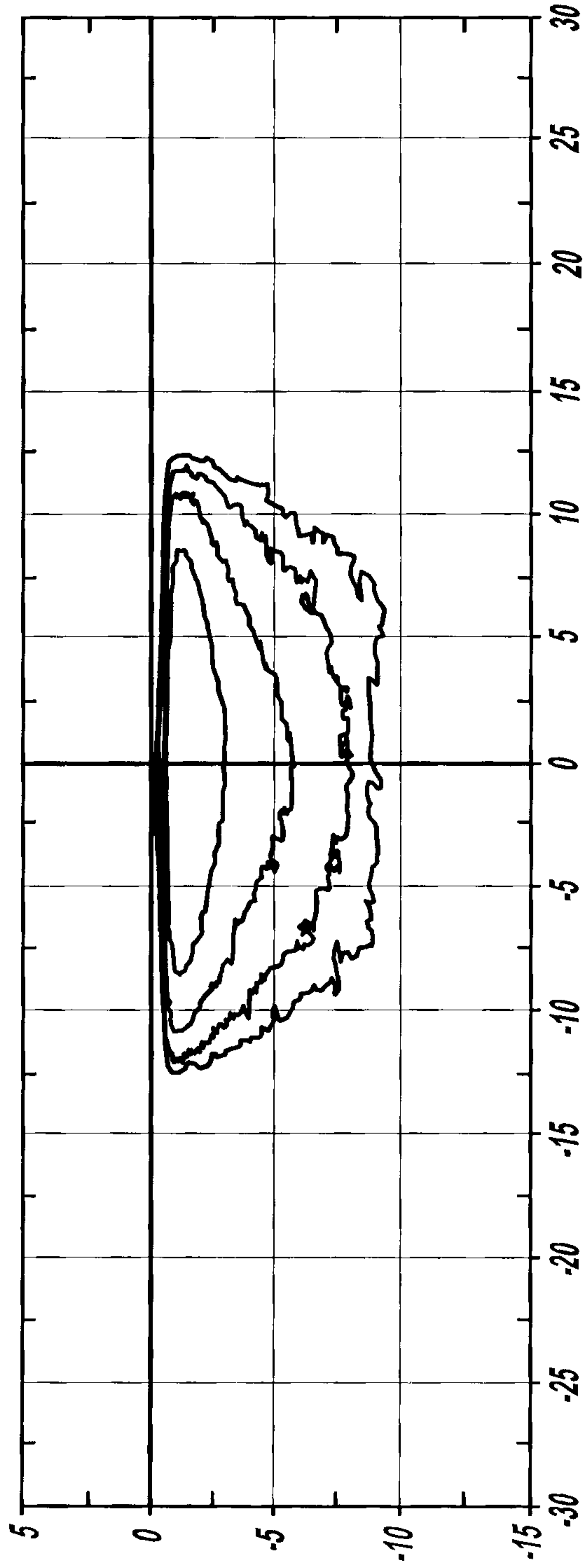
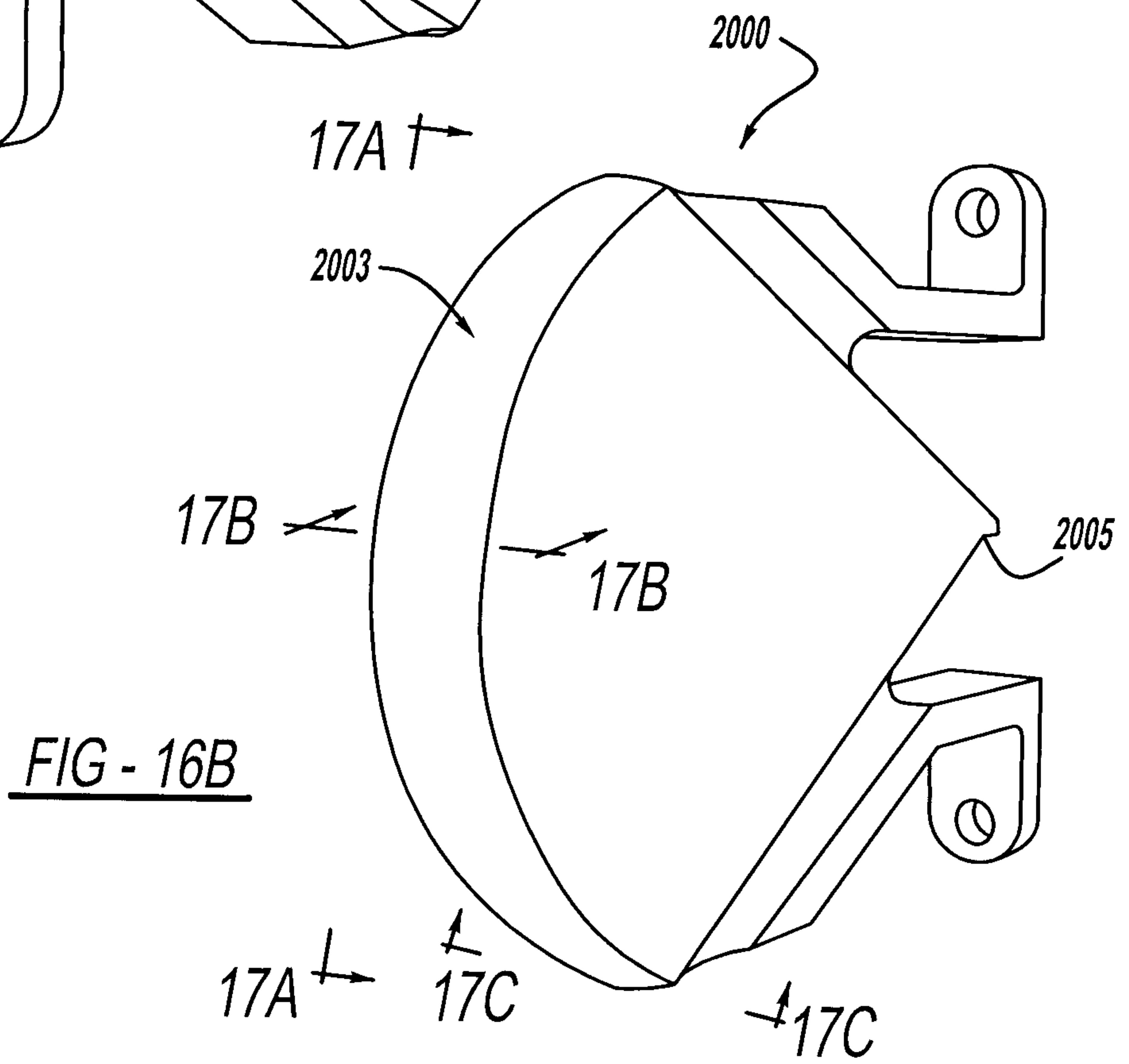
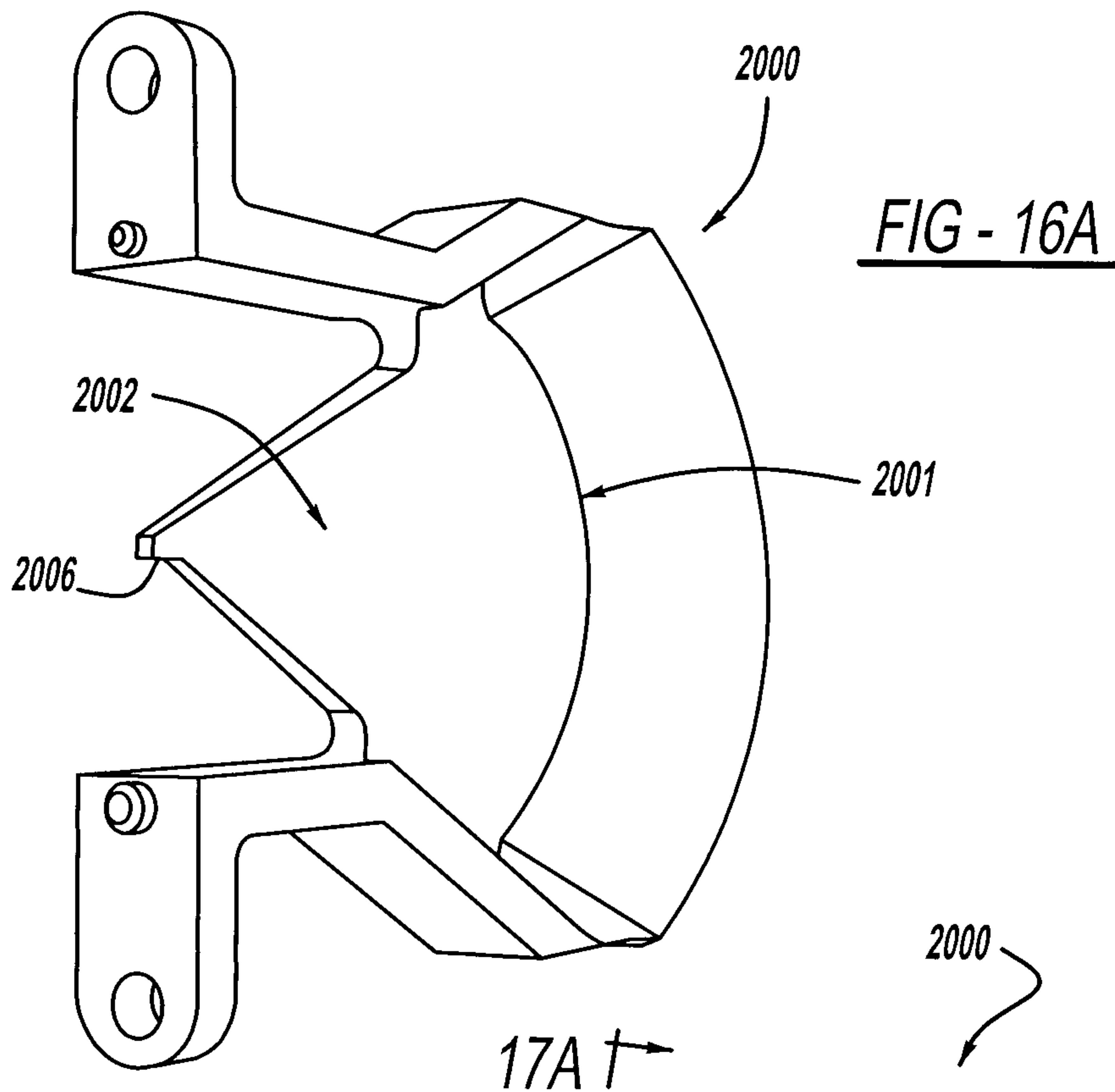

FIG - 15



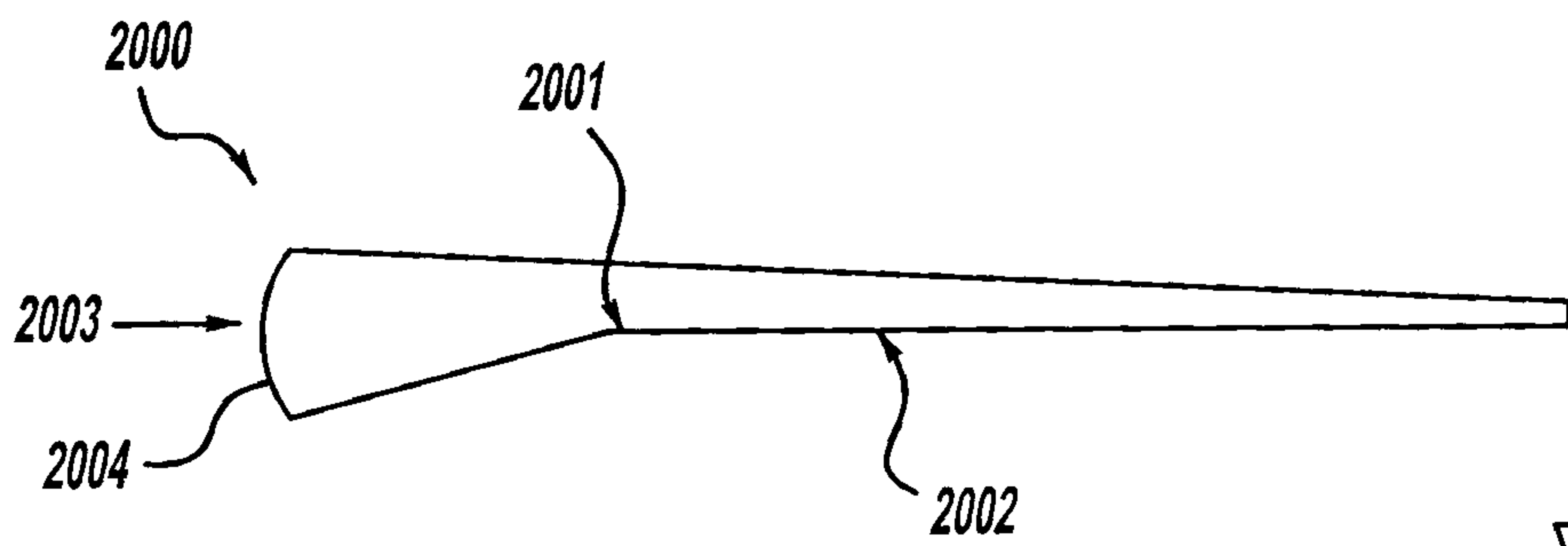
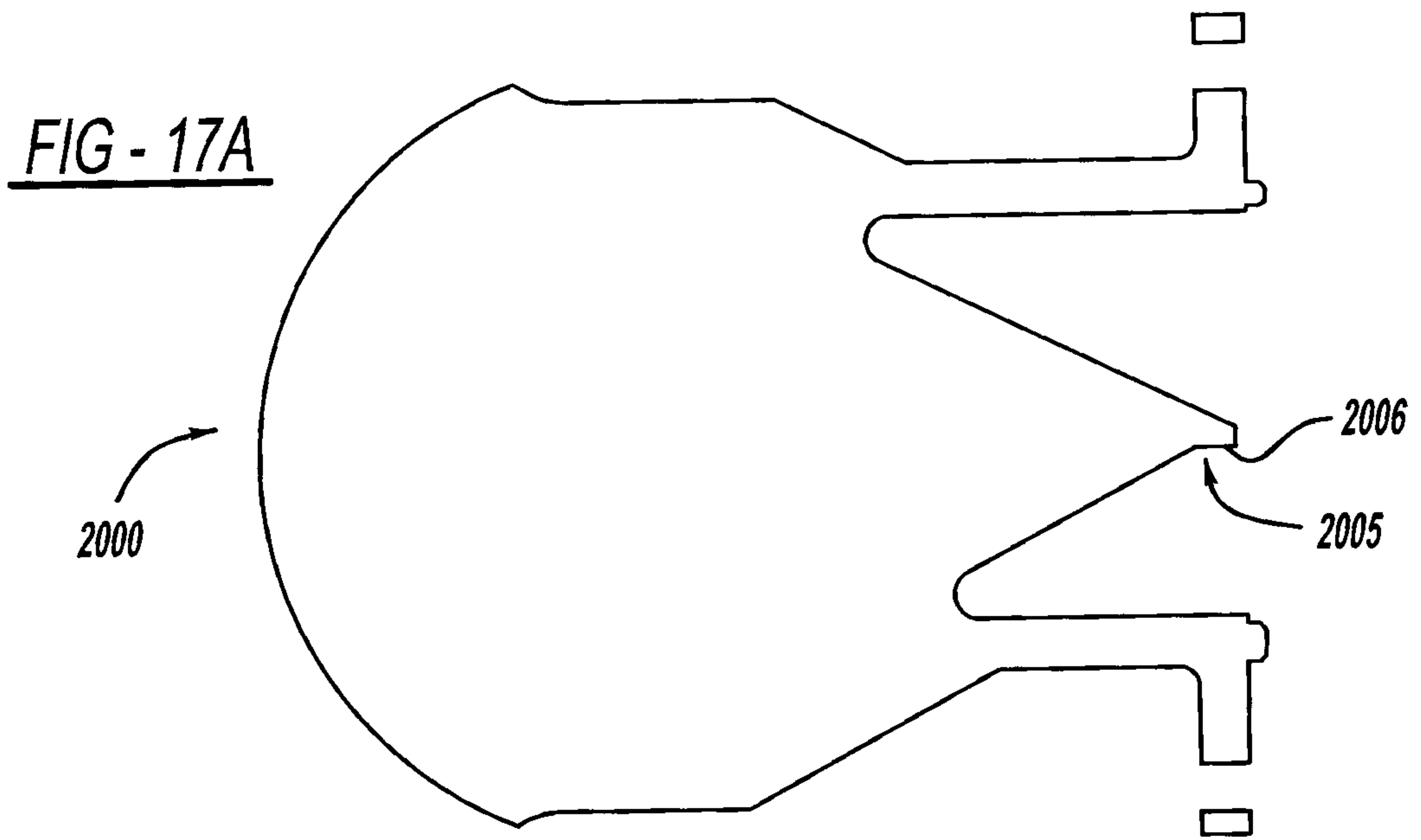
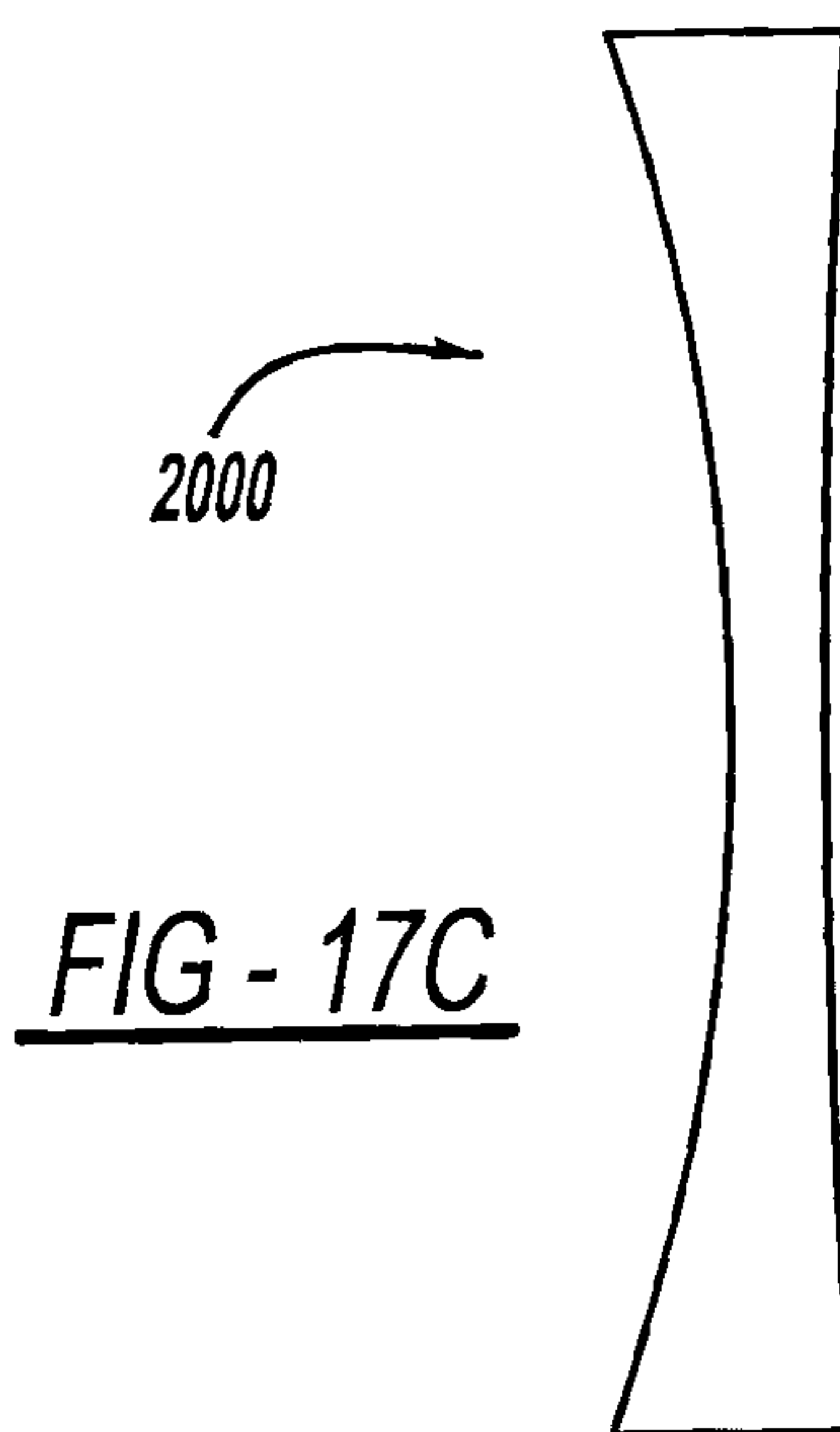

FIG - 17B



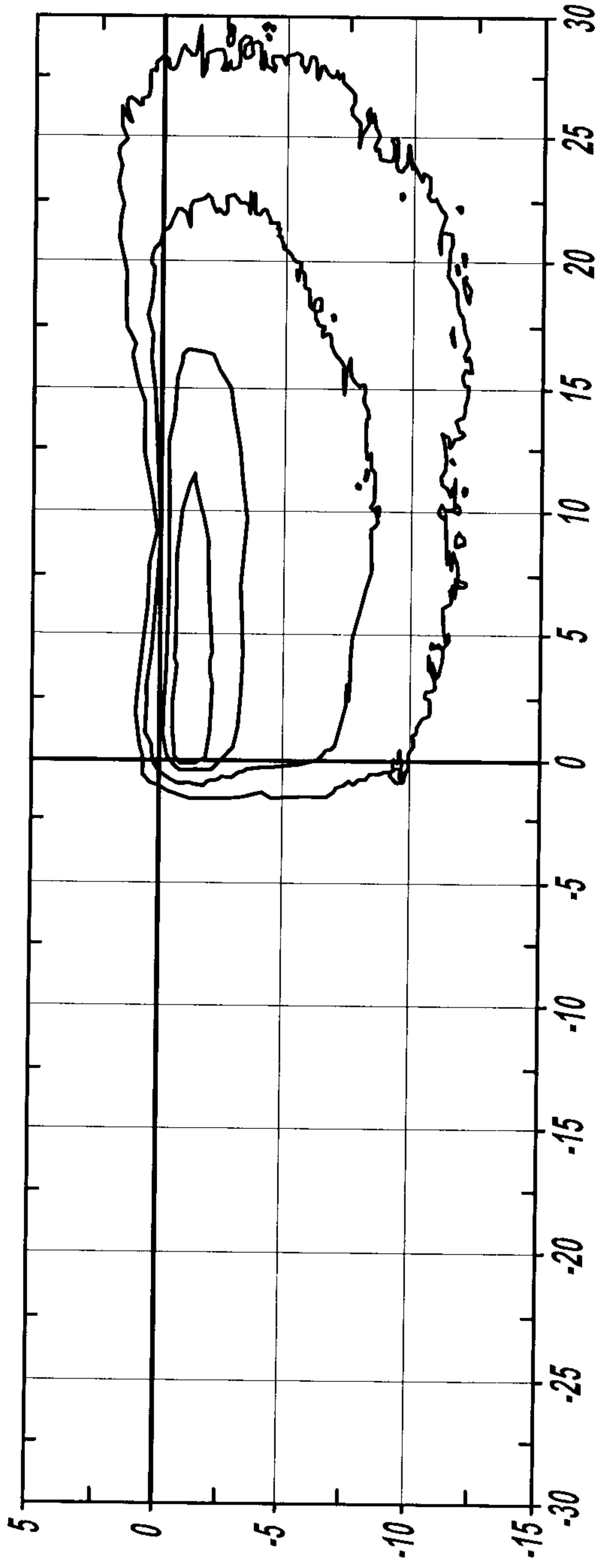

FIG - 18

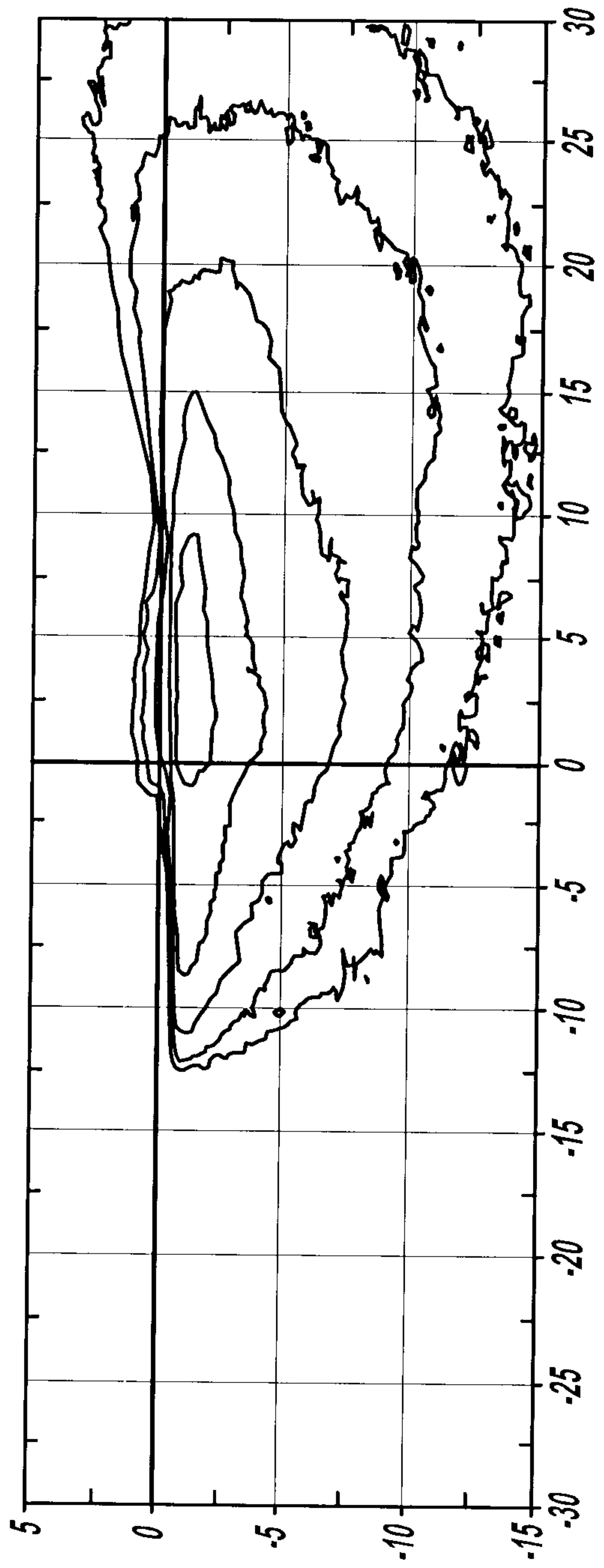

FIG - 19

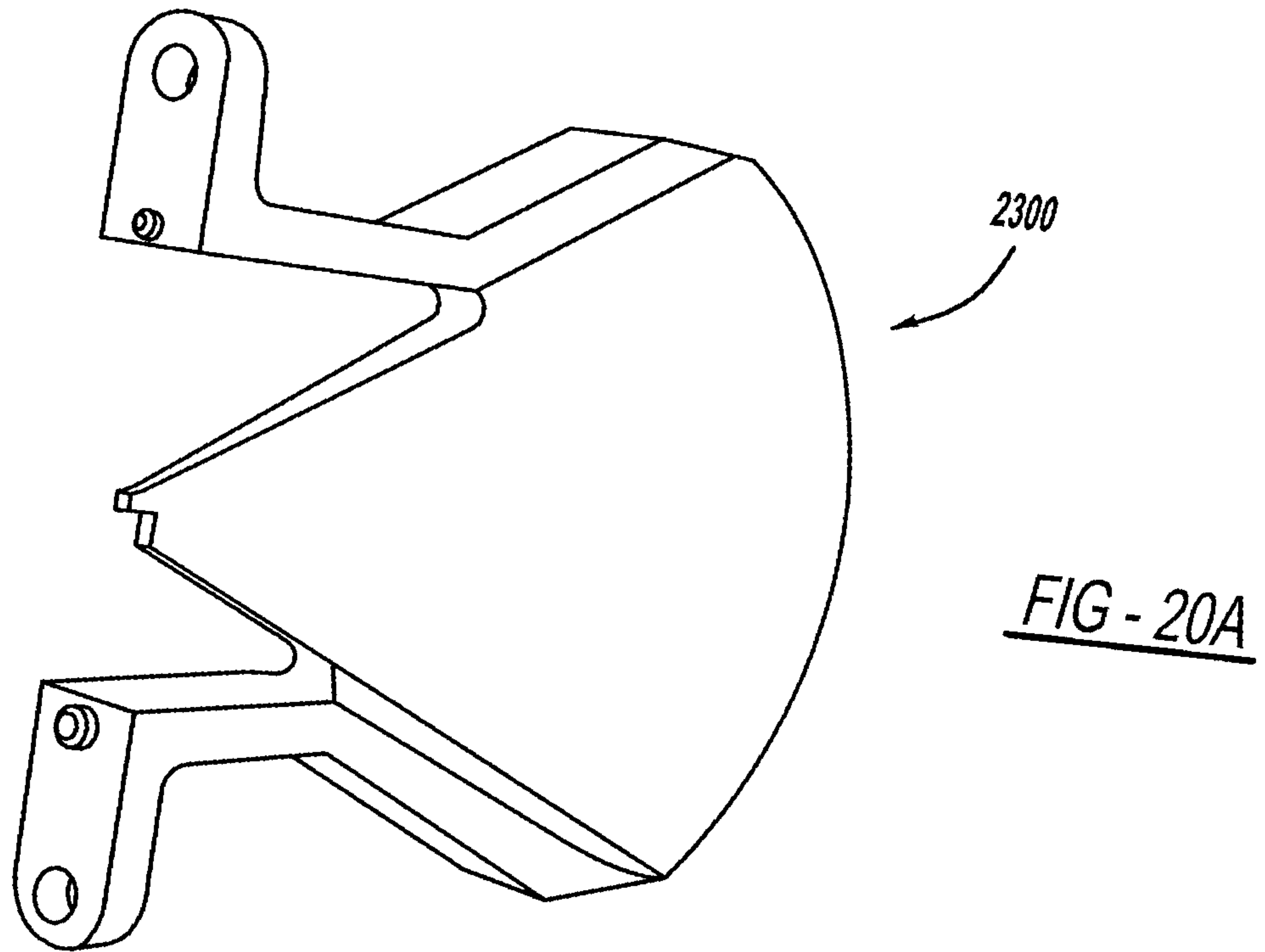

FIG - 20A

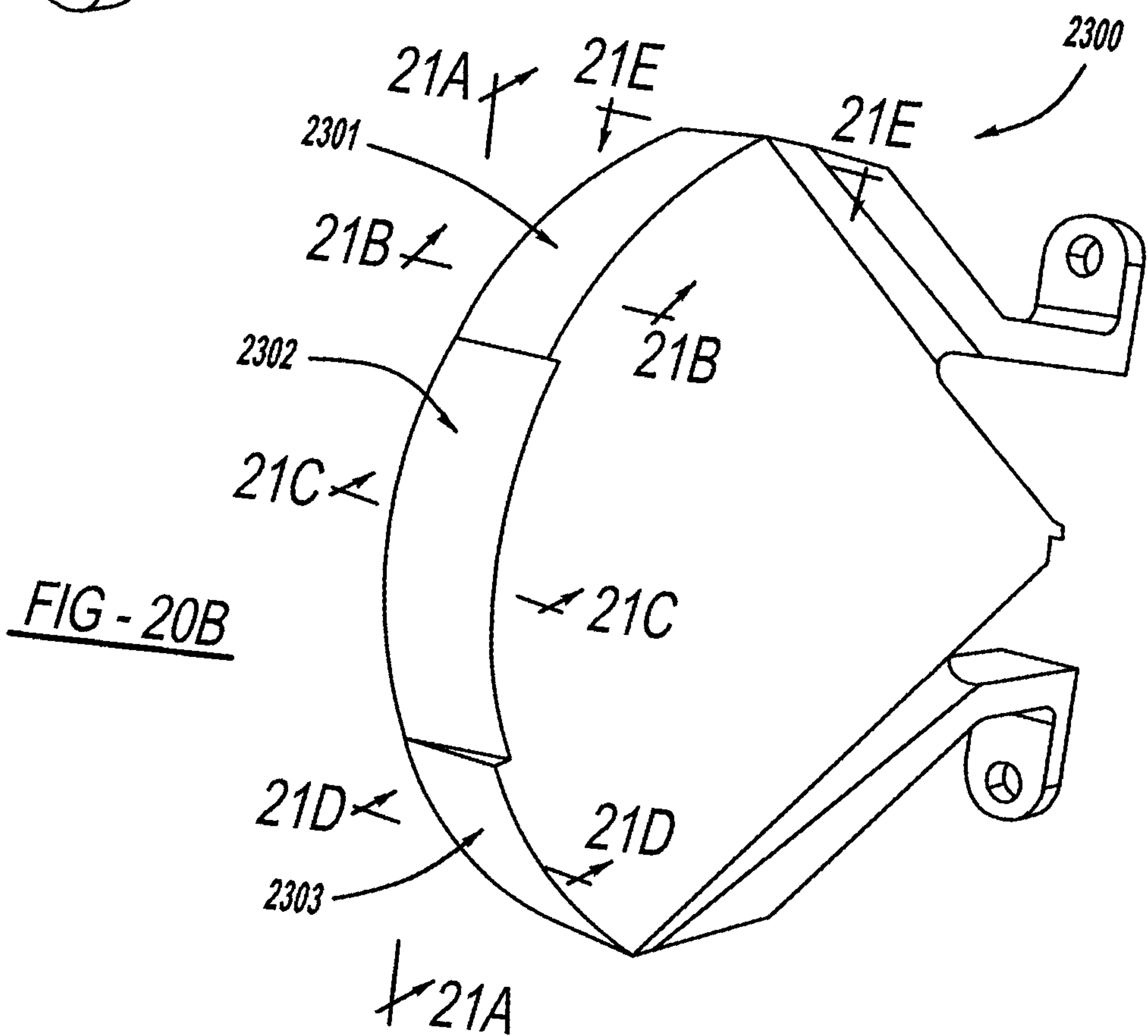
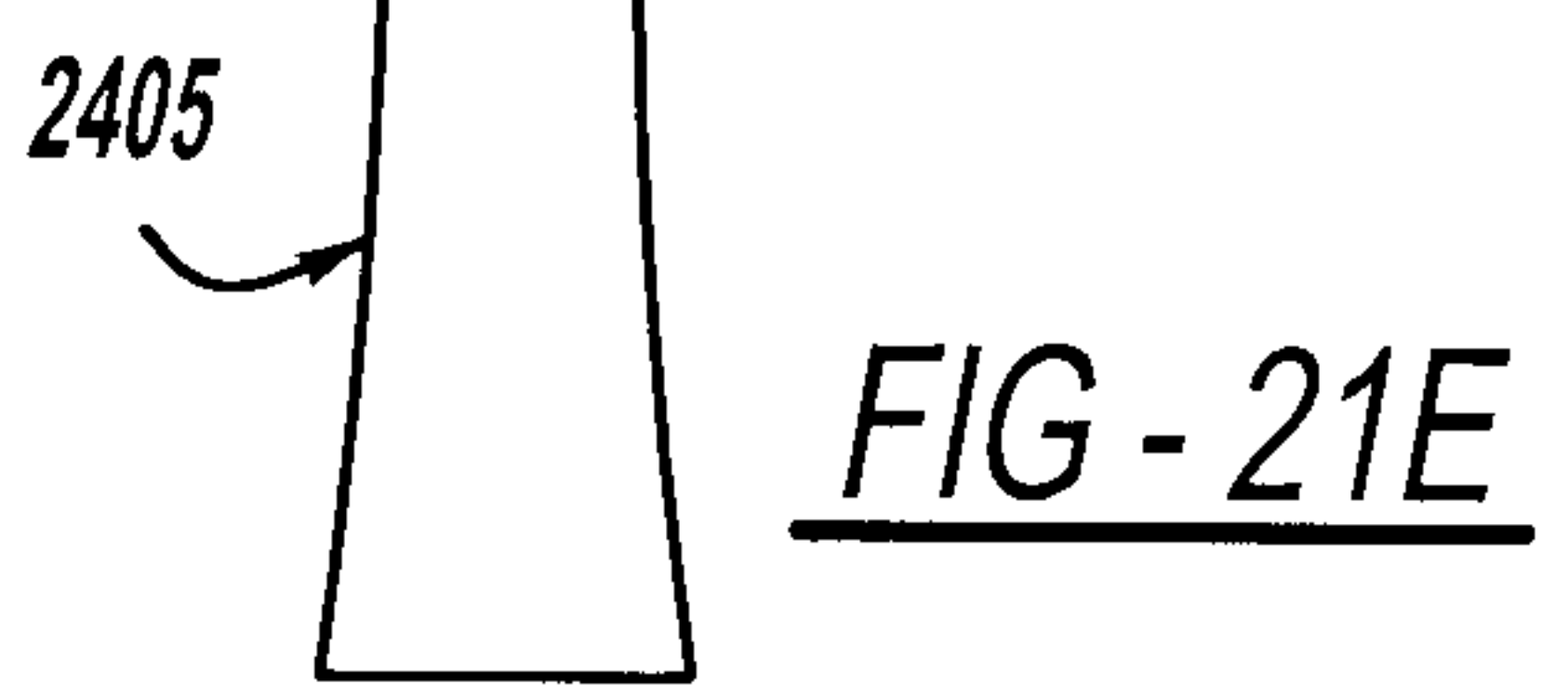
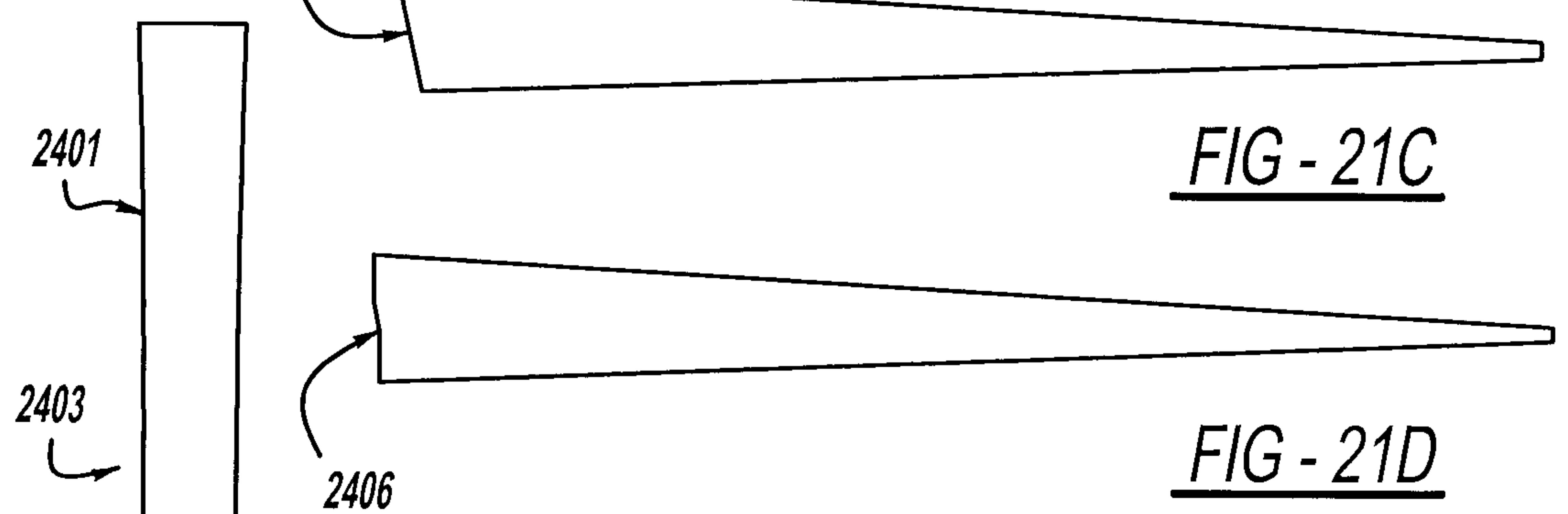
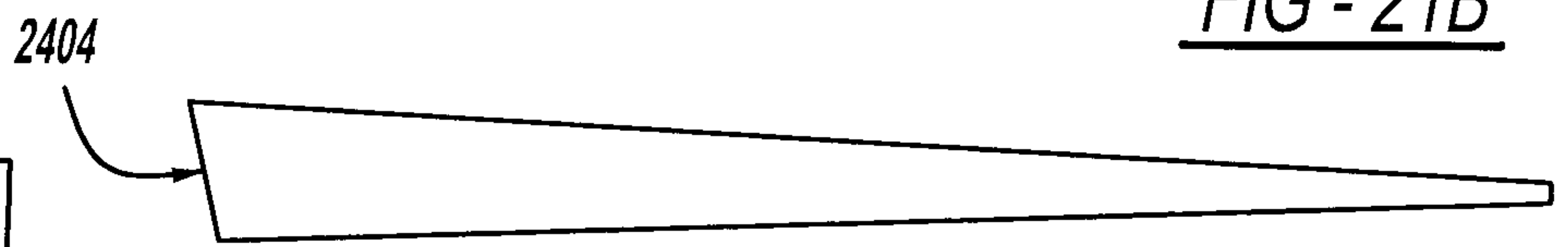
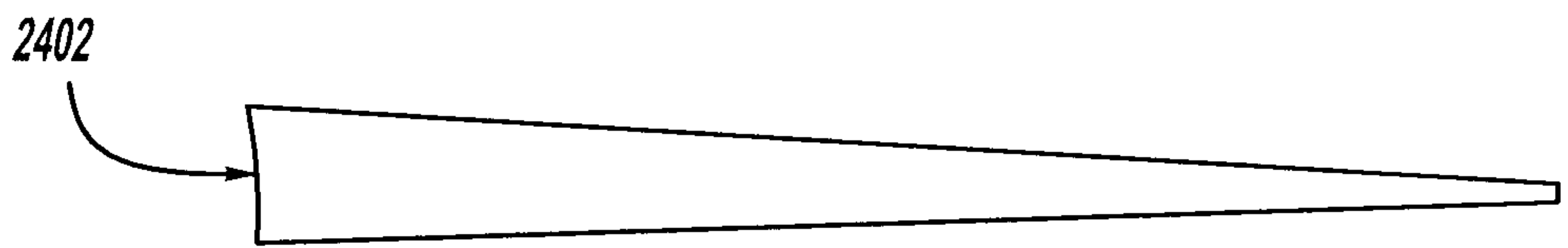
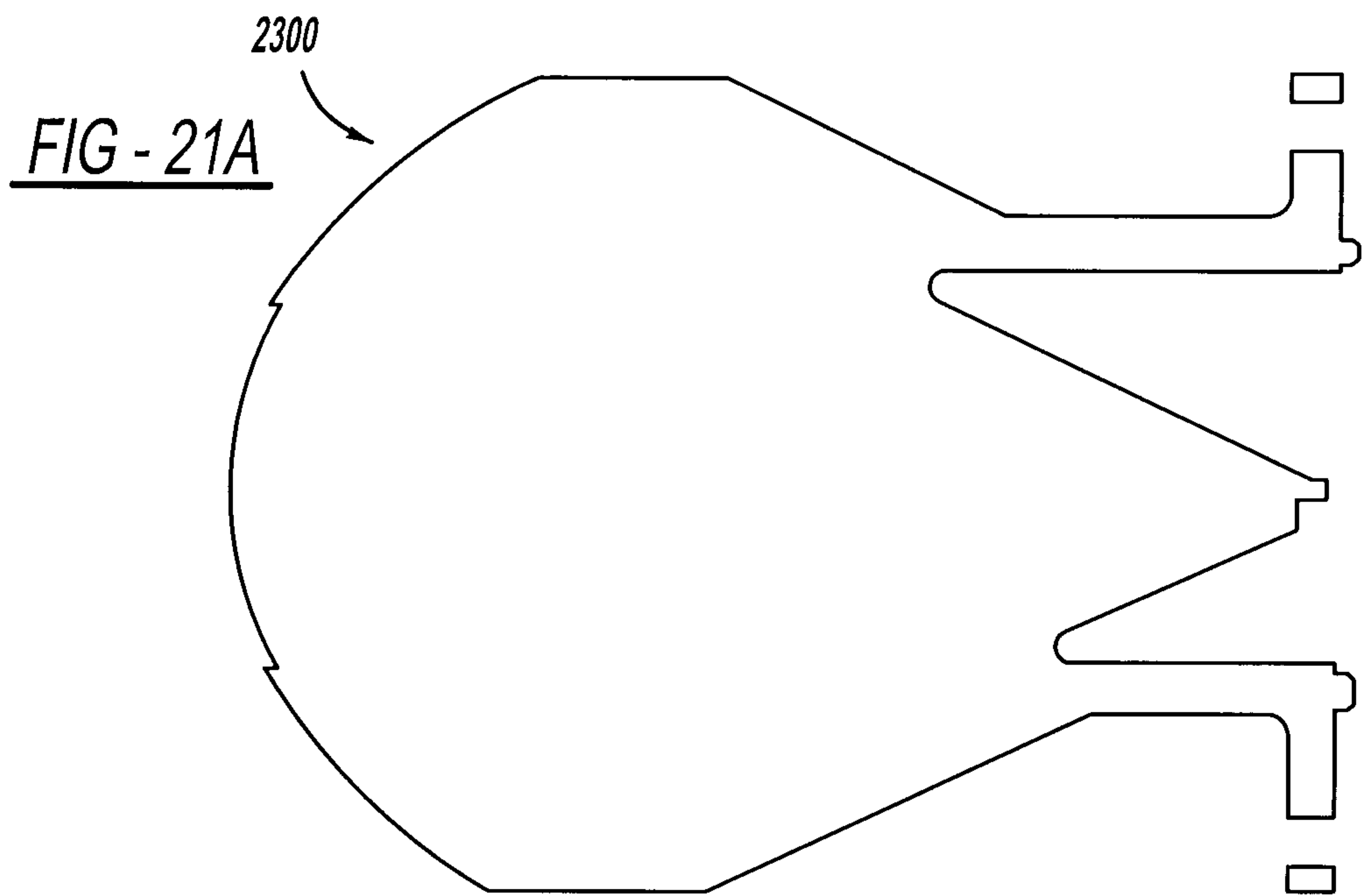

FIG - 20B



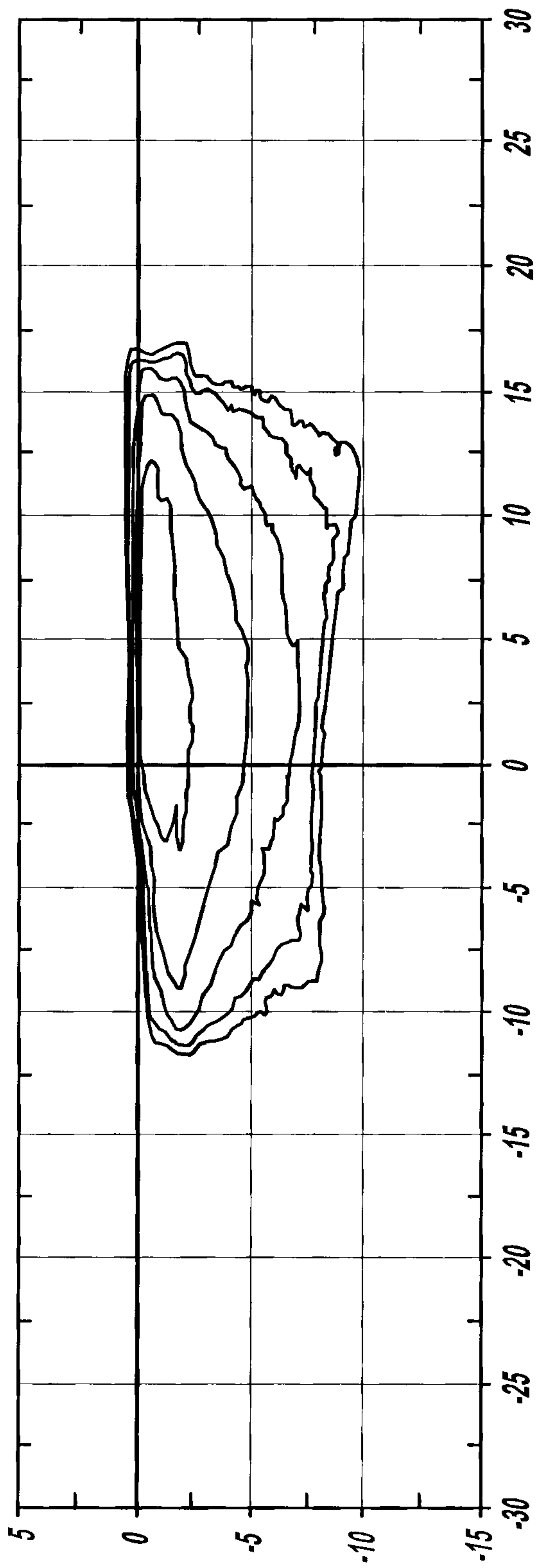

FIG - 22

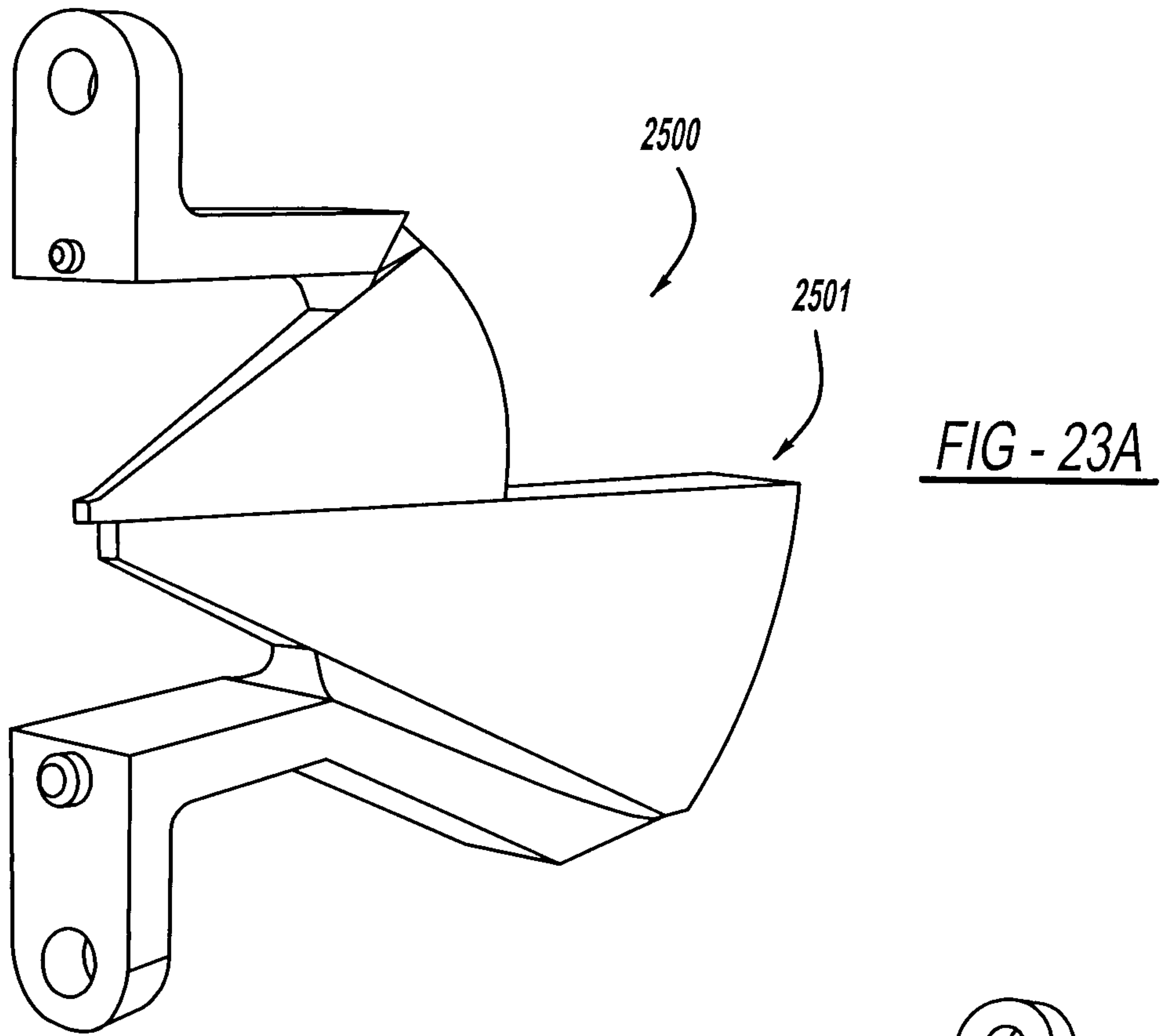

FIG - 23A

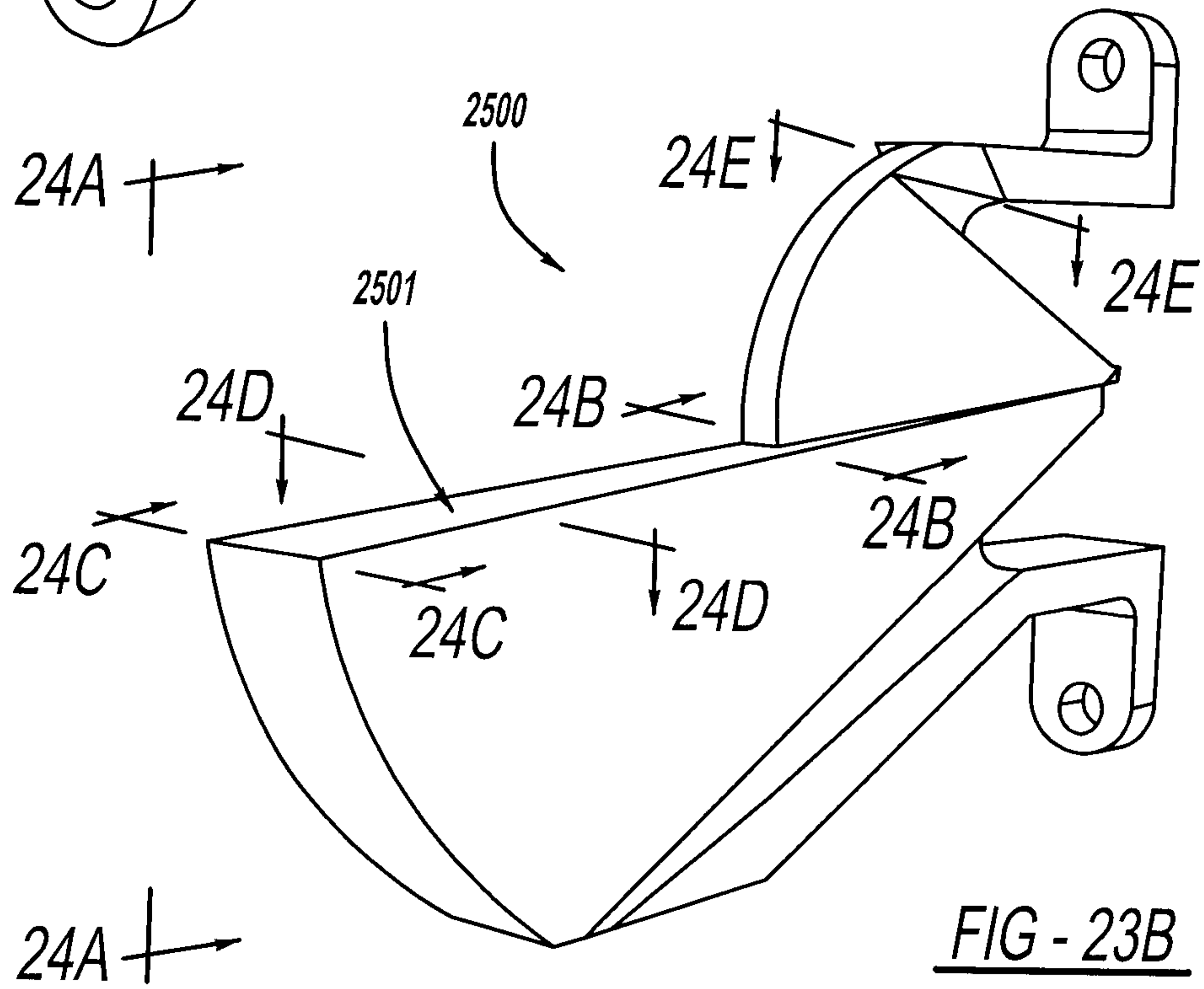

FIG - 23B

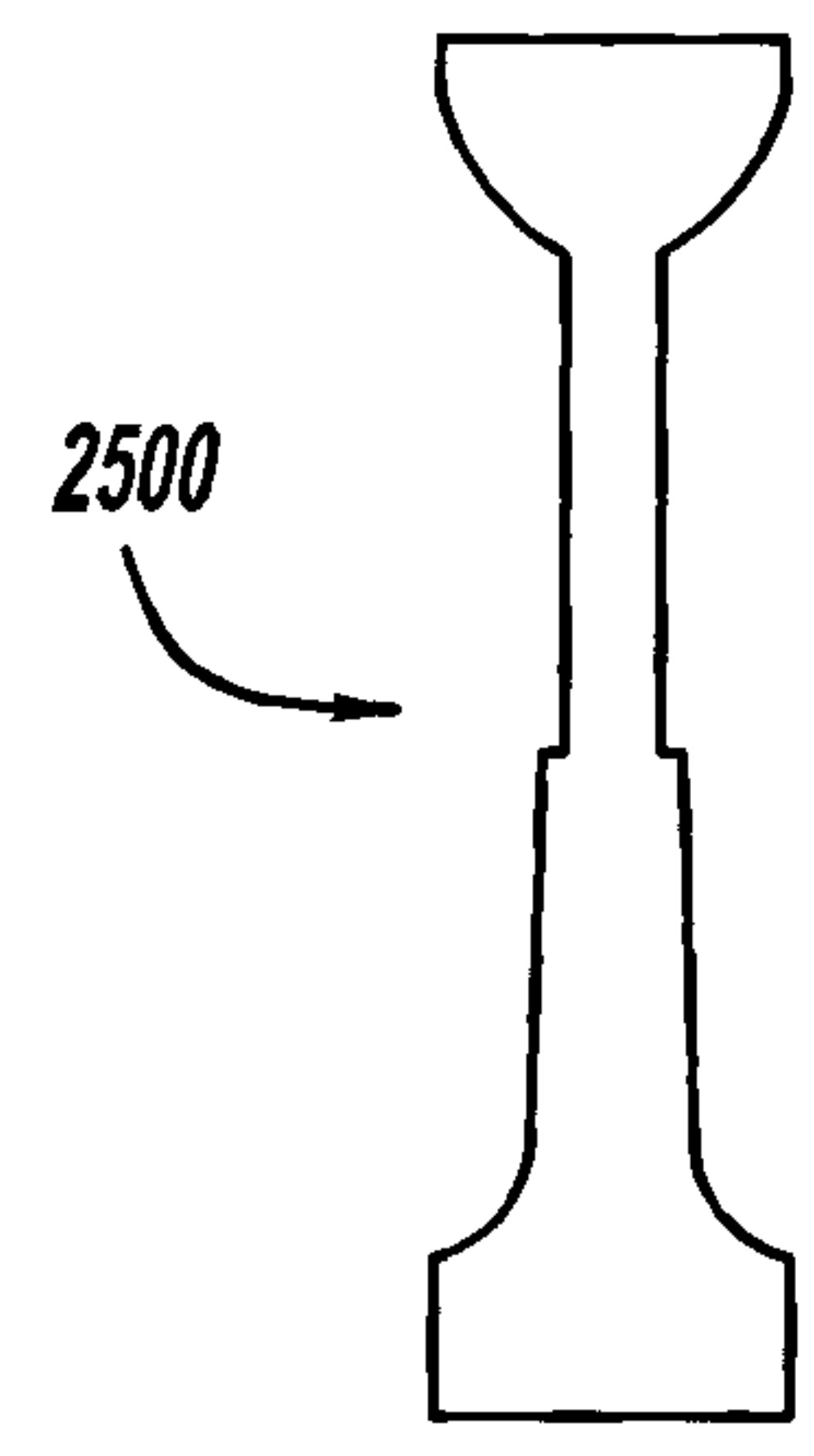
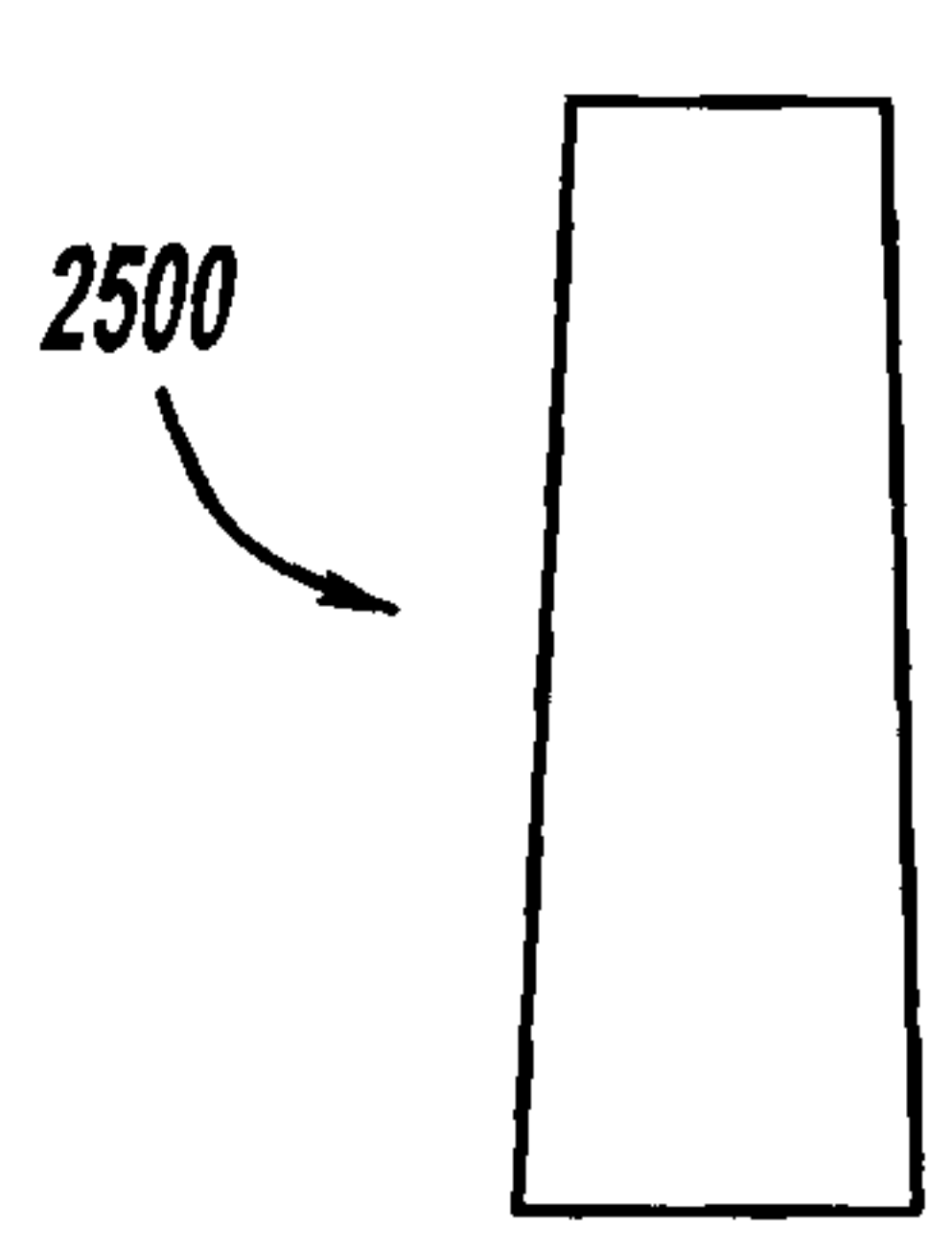
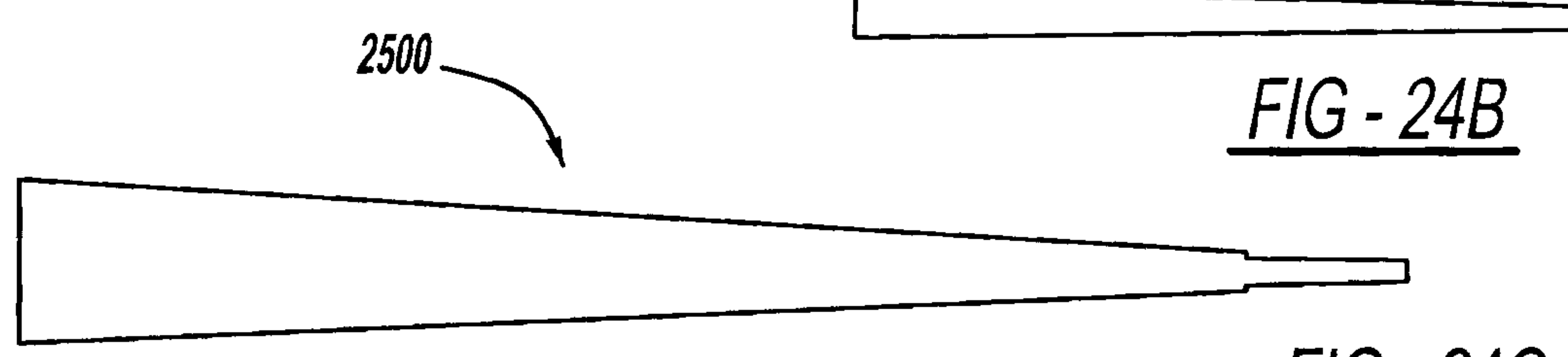
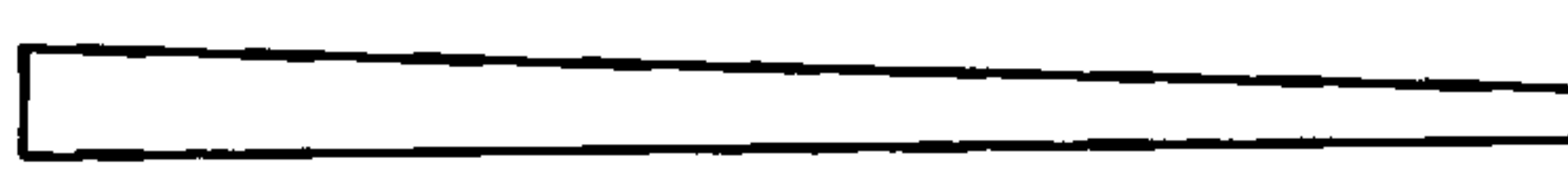
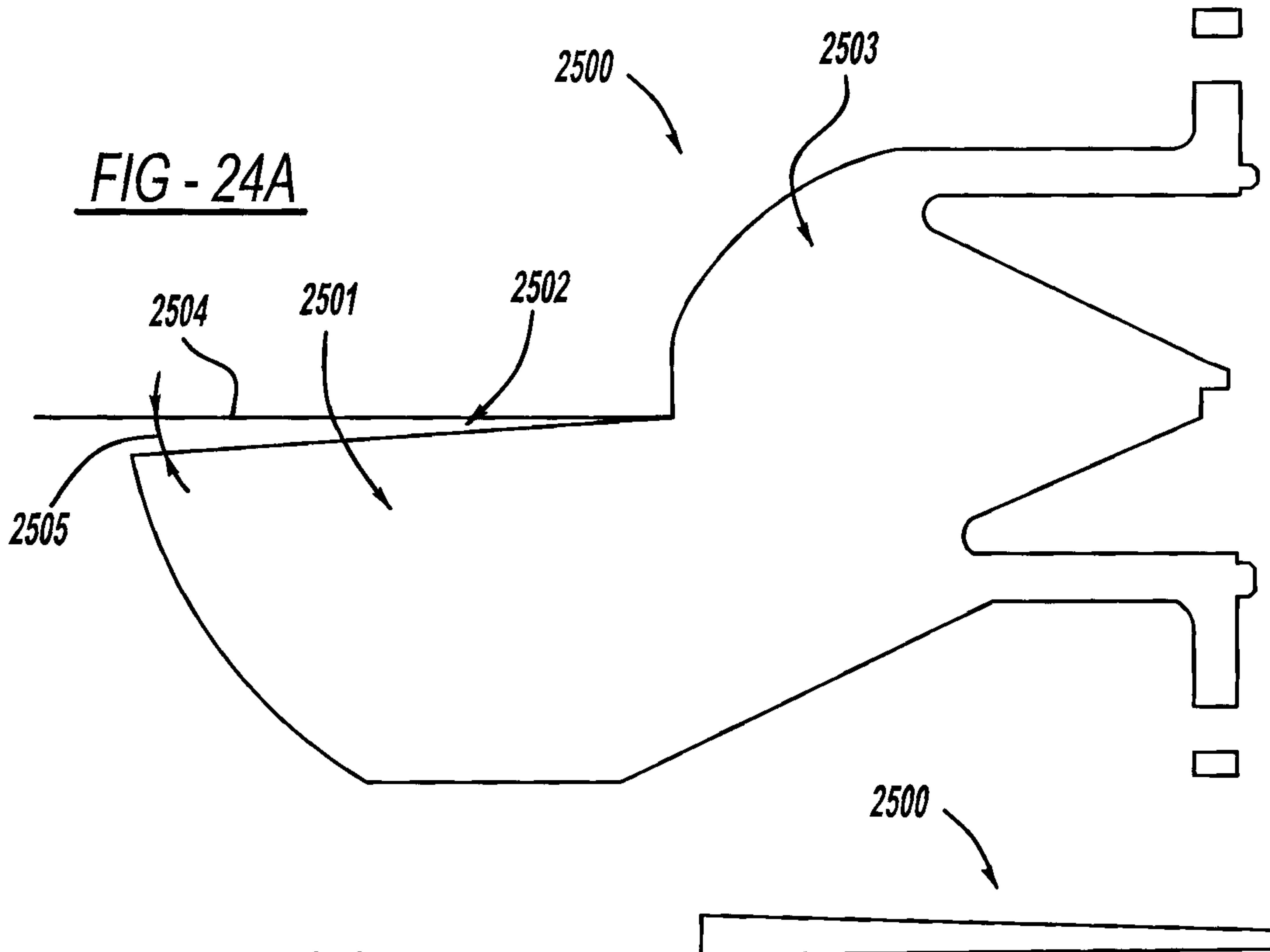

FIG - 24D

FIG - 24E

FIG - 24B

FIG - 24C

FIG - 24A

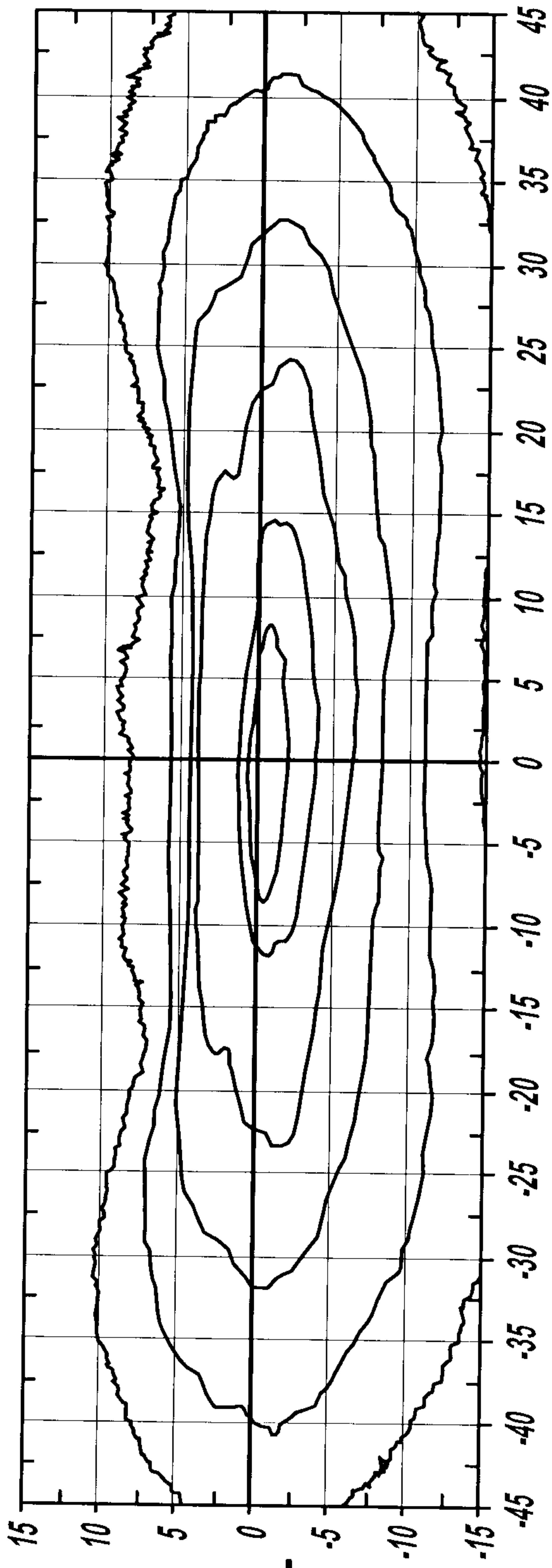

FIG - 25

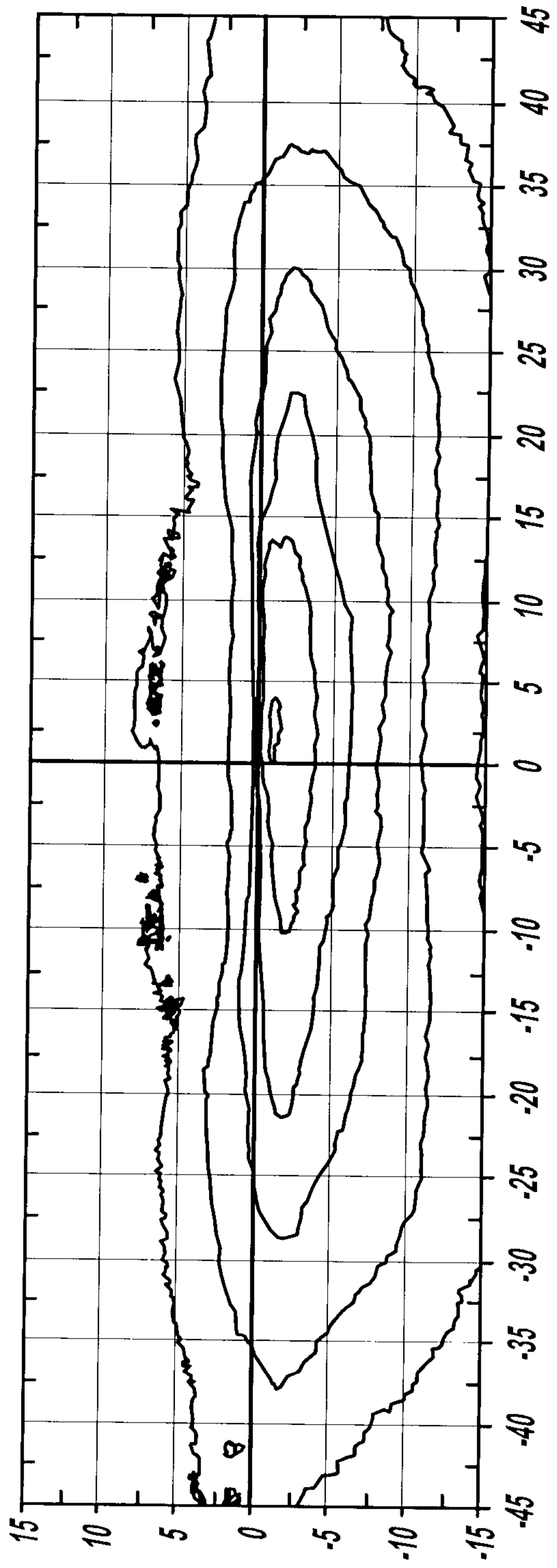

FIG - 26

