

(19) **DANMARK**

(10) **DK/EP 2928794 T4**



Patent- og
Varemærkestyrelsen

(12) **Oversættelse af ændret
europæisk patentskrift**

-
- (51) Int.Cl.: **B 65 G 1/04 (2006.01)**
- (45) Oversættelsen bekendtgjort den: **2024-08-05**
- (80) Dato for Den Europæiske Patentmyndigheds bekendtgørelse om opretholdelse af patentet i ændret form: **2024-07-10**
- (86) Europæisk ansøgning nr.: **13807954.6**
- (86) Europæisk indleveringsdag: **2013-12-05**
- (87) Den europæiske ansøgnings publiceringsdag: **2015-10-14**
- (86) International ansøgning nr.: **EP2013075671**
- (87) Internationalt publikationsnr.: **WO2014090684**
- (30) Prioritet: **2012-12-10 NO 20121488**
- (84) Designerede stater: **AL AT BE BG CH CY CZ DE DK EE ES FI FR GB GR HR HU IE IS IT LI LT LU LV MC MK MT NL NO PL PT RO RS SE SI SK SM TR**
- (73) Patenthaver: **Autostore Technology AS, Stokkastrandvegen 85, 5578 Nedre Vats, Norge**
- (72) Opfinder: **HOGNALAND, Ingvar, Stokkastrandvegen 334, N-5578 Nedre Vats, Norge**
- (74) Fuldmægtig i Danmark: **NORDIC PATENT SERVICE A/S, Bredgade 30, 1260 København K, Danmark**
- (54) Benævnelse: **ROBOT TIL TRANSPORT AF OPBEVARINGSBEHOLDERE**
- (56) Fremdragne publikationer:
WO-A1-2005/077789
WO-A1-2013/167907
JP-A- H04 235 822
JP-A- H10 203 647
JP-A- H11 165 980
JP-A- 2012 116 651
US-A1- 2003 229 416
NO-B1- 317 366

DESCRIPTION

Description

[0001] The present invention relates to a remotely operated vehicle for picking up storage bins from a storage system as defined in the preamble of claim 1.

The invention also relates to a storage system using the inventive vehicle.

A remotely operated vehicle for picking up storage bins from a storage system is known. A detailed description of a relevant prior art storage system is given in WO 98/49075. Further, details of a prior art vehicle being suitable for such a storage system is disclosed in Norwegian patent NO317366, which discloses the features of the preamble of claim 1. More specifically the prior art storage system comprises a three dimensional storage grid containing storage bins that are stacked on top of each other to a certain height. The storage grid is normally constructed as aluminium columns interconnected by top rails. A number of remotely operated vehicles, or robots, are arranged on the top rails. Each vehicle is equipped with a lift for picking up, carrying, and placing bins that are stored inside the storage grid.

Such a prior art storage system and prior art robot is illustrated in figures 1 and 2, respectively. The storage system 3 comprises a robot 1 which is arranged to move on dedicated supporting rails 13 and to receive a storage bin 2 from a storage column 8 within a bin storing grid 15. The storage system 3 includes a plurality of such robots 1 and a dedicated bin lift device 50, the latter being arranged to receive a storage bin 2 from the robot 1 at the top level of the bin storing grid 15 and to convey the storage bin 2 down in a vertical direction to a delivery station 60.

However, the prior art robot 1 shown in both fig. 1 and fig. 2 suffers from several important disadvantages during their operation. Firstly, the particular design of the robot prevents access to all off the available storage columns in the storage system. Furthermore, this particular design may cause an undesirable high torque during lifting and transportation of storage bins, thereby creating potential instability problems, as well as a clear limitation of the robots maximum handling weight. An additional disadvantage caused by the prior art robot design is the fact that only one particular bin and one particular bin height may be accepted for each type of robot in order to ensure adequate stability. Finally, the presence of an integrated yoke / overhang in the upper part of the section receiving the storage bin necessitates an undesired speed reduction at the final stage of the lifting process performed by the yoke suspended vehicle lifting device. The object of the present invention is to solve, or at least substantially alleviate, the above-described disadvantages, that is to provide a vehicle / robot with higher stability properties, higher maximum handling weights, a more effective use of available space during operation and a less time consuming lifting and transporting process of storage bins.

[0002] The above-identified objects are achieved by a remotely operated vehicle as defined in claim 1 and storage system as defined in claim 10. Further beneficial features are defined in

the dependent claims.

In particular, the present invention concerns a remotely operated vehicle or robot for picking up storage bins from a storage system. The inventive vehicle or robot comprises a vehicle body, which vehicle body further comprises a first section for storing vehicle driving means and a second section for receiving any storage bin stored in a storage column within the storage system, a vehicle lifting device which is at least indirectly connected to the vehicle body in order to lift the storage bin into the second section, a first set of vehicle rolling means connected to the vehicle body in order to allow movement of the vehicle along a first direction (X) within the storage system during use and a second set of vehicle rolling means connected to the vehicle body in order to allow movement of the vehicle along a second direction (Y) in the storage system during use. The second direction (Y) is oriented perpendicular to the first direction (X).

[0003] The inventive vehicle is characterized in that the second section comprises a cavity arranged centrally within the vehicle body. This cavity has at least one bin receiving opening facing towards the underlying storage columns during use. In addition, at least one of the two sets of vehicle rolling means is arranged fully within the vehicle body.

[0004] In order to allow easy entrance of the storage bin into the central cavity, its volume should be larger than the largest storage bin intended to be picked from the storage system. Likewise, the cross sectional area of at least one of the at least one bin receiving opening should be larger than the cross sectional area of the storage bin walls oriented parallel to the cavity opening(s).

[0005] The vehicle further comprises means for reversibly and selectively displacing either the first set of vehicle rolling means or the second vehicle rolling means away from an underlying vehicle support within the storage system during a change of vehicle direction between the first direction (X) and the second direction (Y).

[0006] Furthermore, in an embodiment the first section may be arranged relative to the second section in such a way that the cross section of the vehicle parallel to the underlying vehicle support deviates from a quadratic shape.

[0007] In a preferred embodiment the vehicle body covers less or equal to the lateral cross sectional area of one central storage column in the first direction (X) and covers the lateral cross sectional area of more than one central storage column in the second direction (Y) during use. In a more specific example the vehicle body extends beyond the lateral cross sectional area of the central storage column at both sides facing the second direction (Y), i.e. covering also some of the cross sectional areas of the adjacent storage columns extending in the second direction (Y). The degree of extension from the central storage column is preferably equal on both of these sides. Central storage column is defined as the storage column which is immediately below a robot when the latter has reached a position allowing pick-up of a storage bin.

[0008] In order to inter alia allow high vehicle stability both sets of vehicle rolling means is

preferably arranged symmetrically around the cavity, for example near the lower corners of the vehicle. At least one, and most preferably both, set(s) of vehicle rolling means may comprise at least four wheels. Other embodiments such as the use two perpendicular oriented caterpillar belts may be envisaged. Furthermore, both sets have an exterior design matching a corresponding exterior design on supporting rails constituting the vehicle support in order to provide increased lateral stability when interconnected. Such supporting rails would be arranged in a two dimensional matrix on top of a bin storing structure or grid, where the principal directions of both the matrix and the grid are congruent with the vehicle's first direction (X) and second direction (Y).

[0009] The vehicle may advantageously also include position sensing means to allow measurements of the vehicle position within the storage system during use. This position sensing means may comprise a plurality of position sensors arranged in at least some of the positions on the vehicle body which would transverse the locations of vehicle support where the supporting rails are crossing, for example underneath the vehicle, close to its lower corners.

[0010] The present invention also concerns a storage system which comprises a remotely operated vehicle in accordance with the above mentioned features, a vehicle support comprising a plurality of supporting rails forming a two dimensional matrix of guiding meshes, wherein the vehicle support is configured to guide the movements of the vehicle in the first direction (X) and the second direction (Y) during use, a bin storing structure or grid supporting the vehicle support comprising a plurality of storage columns, wherein each of the storage columns is arranged to accommodate a vertical stack of storage bins and wherein the main part of the bin storing structure coincides with positions on the vehicle support where the supporting rails are crossing, and a bin lift device arranged to convey a vehicle delivered storage bin in a direction perpendicular to the lateral plane of the vehicle support between the vehicle support and a delivery station.

[0011] In a preferred embodiment at least some of the supporting rails arranged at the outer lateral border areas of the vehicle support form outer guiding meshes having reduced average cross sectional areas compared to the average cross sectional area of the remaining guiding meshes in the vehicle support. For example, the average reduced cross sectional areas of the outer guiding meshes may be about half of the average cross sectional area of the remaining guiding meshes in the vehicle support. In a particularly preferred embodiment these cross sectional areas of the outer guiding meshes are reduced only along the second direction (Y) of the vehicle support.

[0012] The central arrangement of the cavity in the vehicle body relative to the second direction (Y) effectively remove the undesired torque, thereby improving the stability of the robot or vehicle. This arrangement also results in a lifting and transporting process having a weight distribution with a high degree of symmetry. Furthermore, the novel design allows the same vehicle to be used for lifting and transporting storage bins of heights significantly less than the cavity height (i.e. the height extending from the suspension points of the lifting device

and to the lower edge of the vehicle) since the framework / body surrounding at least part of the bin receiving cavity effectively hinders any undesired bin reeling / wobbling. The presence of the cavity surrounding body also allows maintaining full or nearly full lifting speed almost all the way to its end position within the cavity, as well as initiation of stable bin transportations towards the delivery station prior to a fully completed bin lifting from a storage column. The protective body around the cavity also gives the possibility of starting a descent of the lifting device event prior to the time the vehicle has come to a final halt above the storage column in question. A significantly higher stability and time efficiency is thus achieved.

By arranging at least one set of vehicle rolling means fully within the vehicle or robot body additional stability is obtained during the lifting process since the rolling means is situated closer to the storage bin to be lifted. Of the same reason this arrangement reduces the total load on the lifting device. Furthermore, the arrangement is more space efficient relative to the prior art robot illustrated in figure 2 since the roller means does not give any additional extensions in at least one of the two robots moving directions (X and Y). Production of smaller sized robots / vehicles is also rendered possible.

These and other characteristics of the invention will be clear from the following description of a preferential form of embodiment, given as a non-restrictive example, with reference to the attached drawings wherein:

Fig. 1 is a perspective view of a prior art storage system;

Fig. 2 is a sectional view of a prior art robot or vehicle forming part of a storage system as illustrated in fig. 1;

Fig. 3 is a perspective base view of a remotely operated vehicle according to the present invention;

Fig. 4 is a perspective top view of a remotely operated vehicle according to the present invention;

Fig. 5 is a perspective top view of a robot assembly comprising a remotely operated vehicle according to the present invention, a storage bin and a fully enclosing cover,

Fig. 6 is a perspective top view of a bin storing grid and a vehicle support in accordance with the present invention;

Fig. 7 is a perspective side view of a bin storing grid and a vehicle support in accordance with the present invention;

Fig. 8 is a perspective side view of part of a storage system in accordance with the present invention including a bin storing grid, a vehicle support and a remotely operated vehicle; and

Fig. 9 is a schematic top view of a remotely operated vehicle moving on a two dimensional matrix of supporting rails.

[0013] Fig. 1 is a schematic, partly cut perspective view of a storage system according to the prior art, and fig. 2 is a sectional view of a corresponding prior art robot. Both figures have already been referred to earlier in the text. Fig. 3 and 4 gives a perspective view in two different angles of the inventive robot 1 comprising a rectangular vehicle body or framework 4 with a cavity 7 centrally arranged within the body 4, a top lid 72 covering the top part of the body 4, a first set of four wheels 10 mounted inside the cavity 7 and in parallel to the interior walls of the body 4 and a second set of four wheels 11 mounted in parallel to the exterior walls of the body 4. The first and second set of wheels 10,11 are oriented perpendicular to each other. Further, the vehicle body 4 also includes side parts 5,5a,5b arranged on both sides of the cavity 7 along at least one of the robots 1 direction of movements. For the sake of clarity a Cartesian coordinate system is shown with its X, Y and Z axes aligned along the principal directions of the rectangular vehicle body 4. The size of the cavity 7 is adapted to contain necessary component for a lifting device 9 and to at least completely contain the largest storage bin 2 intended to be picked up by the robot 1.

[0014] Fig. 5 gives a perspective view of a robot assembly where the body 4 is completely covered by an enclosing cover 73 comprising handles 74 and transmission means / control panel 75. The design of the enclosing cover 73 is adapted to the particular shape given by the body 4 and the protruding wheels 10. Fig. 5 also shows a small part of a storage bin 2 arranged fully inside the cavity 7 and a small part of the lifting device 9. The latter is preferably composed of inter alia four vertically moveable metal bands suspended on the cavity facing side of the top lid 72 in their upper ends and steering rods at the lower ends capable of being steered and fastened into adapted cavities / areas in the storage bin 2 to be picked.

[0015] The structural principles of a grid assembly comprising a bin storing structure or grid 15, integrated supporting rails 13 constituting the vehicle support 14 and a grid supporting base 76 are illustrated in figs. 6 and 7. The grid 15 comprises a plurality of pillars being arranged with internal distances adapted to accommodate storage bins 2 to be stored in stacks inside the grid 15. The rectangular arrangements of four adjacent pillars therefore constitute a storage column 8. Both the pillars and the rails 13 may be made of Aluminium. As for fig. 3 and 4 a Cartesian coordinate system is shown aligned along the principal directions of the grid assembly to ease the understanding. The supporting rails 13 form a two dimensional matrix of rectangular meshes, and the cross sectional area of most of these meshes coincide with the cross sectional area of each storage columns 8 set up by the underlying grid 15. The meshes at the border area 17,18 of the vehicle support 14 (at both sides in direction Y) is illustrated with cross sectional areas smaller than the remaining meshes. The size of the border meshes 17,18 should preferably be adapted to the degree of extension beyond a central storage column 8a situated immediately below the cavity 7 of the robot 1 when the latter is in a position for initiating pick up of a storage bin 2 contained in the central storage column 8a (see fig. 8 and 9). In this way the robot 1 may reach all the storage columns 8 in the storage system 3, i.e. independently of the robot orientation in the Y direction. For example, if the robot 1 extends exactly over the cross sectional area of one central storage column 8a in the X direction and over $\frac{1}{2}$ of the cross sectional area of the adjacent storage column 8b in the Y direction, the cross sectional area of the meshes 17,18 at the border area in the Y direction should be

approximately $\frac{1}{2}$ of the cross sectional area of the remaining meshes. The primary function of these border meshes 17,18 is thus to allow sufficient space for the robot 1 having the novel design.

[0016] Fig. 8 shows the robot 1 in a lifting position above the central storage column 8a adjacent to the border area 17,18 of the grid assembly. The vehicle lifting device 9 is in this embodiment lowered a distance into the central storage column 8a in order to hook onto and lift up the underlying storage bin 2. As seen in the exemplary situation in figs. 8 the robot 1, having the body 4 extended in the Y direction compared to the X direction, may be driven all the way to the edge of the grid 15 when the border area is designed with additional border meshes 17,18 with a Y directional width approximately $\frac{1}{2}$ of the Y directional widths of the remaining meshes in the grid 15.

[0017] To better illustrate the movement of the robot 1 on the supporting rails 13 constituting the vehicle support 14 some exemplary positions of robots 1 on a grid assembly is illustrated in fig. 9. The thick arrows drawn in the centre of the robots 1 indicate allowed moving directions. When the robot 1 is situated with its cavity 7 exactly above a central storage column 8a, as is the case for the top left and mid centred robot 1, the arrangement of the supporting rails 13 allow movement in both X and Y directions. Any other positions on the grid assembly restrict the robot's 1 movement on the vehicle support 14 either in X direction (lower right robot 1) or in Y direction (top centered and bottom left robot 1). To allow determination of the robot position it is considered advantageous to equip each robot 1 with one or more position sensors 16, for example optical sensors. Such sensors should 16 preferably be mounted in one or more areas of the robot 1 which ensures that the sensors 16 have both non-obstructed view to the underlying supporting rails 13 and that they pass directly above or close to the positions on the vehicle support 14 in which the rails 13 are crossing. The readings from the sensors 16 may inter alia dictate the further movement of the robot 1 and/or the operation of the vehicle lifting device 9. All operations of the robot 1 are controlled by wireless communication means 75 and remote control units. This includes control of the robot movement, the vehicle lifting device and the position measurements.

In the preceding description, various aspects of the apparatus according to the invention have been described with reference to the illustrative embodiment. For purposes of explanation, specific numbers, systems and configurations were set forth in order to provide a thorough understanding of the apparatus and its workings.

List of reference numerals / letters:

[0018]

- 1 Remotely operated vehicle / robot
- 2 Storage bin

- 3 Storage system
- 4 Vehicle body / framework
- 5 First section (of vehicle body) / component section / side parts
 - 5a First section, left
 - 5b First section, right
- 6 Vehicle driving means / motor unit
- 7 Vehicle storage space / second part / cavity / centrally arranged cavity
- 8 Storage column
 - 8a Central storage column
 - 8b Adjacent storage column
- 9 Vehicle lifting device
- 10 First set of vehicle rolling means / First set of wheels
- 11 Second set of vehicle rolling means / Second set of wheels
- 12 Bin receiving opening
- 13 Supporting rail
- 14 Vehicle support
- 15 Bin storing structure / grid
- 16 Position sensing means / position sensor
- 17 Left outer lateral border area of vehicle support / left border mesh
- 18 Right outer lateral border area of vehicle support / right border mesh
- 50 Bin lift device
- 60 Delivery station / port

70	Yoke / overhang
72	Top lid
73	Enclosing cover
74	Handles
75	Transmission means / control panel / wireless communication means
76	Grid supporting base

REFERENCES CITED IN THE DESCRIPTION

Cited references

This list of references cited by the applicant is for the reader's convenience only. It does not form part of the European patent document. Even though great care has been taken in compiling the references, errors or omissions cannot be excluded and the EPO disclaims all liability in this regard.

Patent documents cited in the description

- [WO9849075A \[0001\]](#)
- [NO317366 \[0001\]](#)

PATENTKRAV

1. Fjernstyret køretøj (1) til opsamling af opbevaringsbeholdere (2) fra et opbevaringssystem (3), der omfatter

et køretøjslegeme (4), der omfatter en første sektion (5, 5a, 5b) til opbevaring af køretøjsdrivmidler (6) og en anden sektion (7) til modtagelse af en hvilken som helst opbevaringsbeholder (2) opbevaret i en opbevaringssøjle (8, 8a, 8b) inde i opbevaringssystemet (3),

en køretøjsløfteanordning (9) mindst indirekte forbundet med køretøjslegemet (4) til løft af opbevaringsbeholderen (2) ind i den anden sektion (7),

et første sæt af køretøjsrullemidler (10) forbundet med køretøjslegemet (4), der muliggør bevægelse af køretøjet (1) langs en første retning (X) inde i opbevaringssystemet (3) under anvendelse og

et andet sæt af køretøjsrullemidler (11) forbundet med køretøjslegemet (4), der muliggør bevægelse af køretøjet (1) langs en anden retning (Y) i opbevaringssystemet (3) under anvendelse,

hvor den anden retning (Y) er vinkelret på den første retning (X),

kendetegnet ved, at

den anden sektion (7) omfatter et centralt anbragt hulrum (7) inde i køretøjslegemet (4), hvilket hulrum (7) har mindst én beholdermodtagelsesåbning (12), der vender ind mod opbevaringssøjlerne (8, 8a, 8b) under anvendelse, og

mindst ét af sættene af køretøjsrullemidler (11) er anbragt helt inde i køretøjslegemet (4), og

køretøjet endvidere omfatter midler til reversibelt og selektivt at flytte enten det første sæt af køretøjsrullemidler eller det andet køretøjsrullemiddel væk fra en underliggende køretøjsbærer (14) inde i opbevaringssystemet (3) under en ændring af køretøjsretning mellem den første retning (X) og den anden retning (Y).

2. Fjernstyret køretøj (1) ifølge krav 1, **kendetegnet ved, at** køretøjslegemet (4) dækker maksimalt det laterale tværsnit af én central opbevaringssøjle (8a) i den første retning (X) og dækker det laterale tværsnit af mere end én central opbevaringssøjle (8a, 8b) i den anden retning (Y) under anvendelse.

3. Fjernstyret køretøj (1) ifølge krav 2, **kendetegnet ved, at** køretøjslegemet (4) strækker sig ud over det laterale tværsnit af den centrale opbevaringssøjle (8a, 8b) i begge sider i den

anden retning (Y).

4. Fjernstyret køretøj (1) ifølge krav 3, **kendetegnet ved, at** forlængelsen ud over det laterale tværsnit af den centrale opbevaringssøjle (8a,8b) er ens på begge sider i den anden retning (Y).
- 5
5. Fjernstyret køretøj (1) ifølge et af de foregående krav, **kendetegnet ved, at** begge sæt af køretøjsrullemidler (10, 11) er symmetrisk fordelt omkring det centralt anbragte hulrum (7).
- 10
6. Fjernstyret køretøj (1) ifølge et af de foregående krav, **kendetegnet ved, at** mindst ét sæt af køretøjsrullemidler (10, 11) omfatter mindst fire hjul.
7. Fjernstyret køretøj (1) ifølge et af de foregående krav, **kendetegnet ved, at** begge sæt af køretøjsrullemidler (10, 11) har et ydre design, der matcher et tilsvarende ydre design på bæreskiner (13), der udgør køretøjsbæreren (14) for at tilvejebringe øget lateral stabilitet ved forbindelse med hinanden,
- 15
- hvor bæreskinerne (13) er anbragt i en todimensional matrix oven på en beholderopbevaringsstruktur (15), hvor hovedretningen for matrixen og beholderopbevaringsstrukturen (15) er sammenfaldende med køretøjets (1) første retning (X) og anden retning (Y).
- 20
8. Fjernstyret køretøj (1) ifølge et af de foregående krav, **kendetegnet ved, at** køretøjet (1) omfatter positionsdetekteringsmidler (16) til at muliggøre målinger af køretøjspositionen inden i opbevaringssystemet (3) under anvendelse.
- 25
9. Fjernstyret køretøj (1) ifølge krav 8, **kendetegnet ved, at** positionsbestemmelsesmidlet (16) omfatter en flerhed af sensorer anbragt i mindst nogle af positionerne på køretøjslegemet (4) der, under anvendelse, krydser positionerne for køretøjsbærer (14), hvor bæreskinerne (13) krydser hinanden.
- 30
10. Opbevaringssystem (3), **kendetegnet ved at** omfatte
- et fjernstyret køretøj (1) ifølge et af kravene 1-9,
 - en køretøjsbærer (14), der omfatter en flerhed af bæreskiner (13), der danner en todimensional matrix af føringsfelter, hvor køretøjsbæreren (14) er konfigureret til at føre

køretøjets (1) bevægelser i den første retning (X) og den anden retning (Y) under anvendelse,

- en beholderopbevaringsstruktur (15), der bærer køretøjsbæreren (14), hvilken struktur (15) omfatter en flerhed af opbevaringssøjler (8, 8a, 8b),

5 hvori hver opbevaringssøjle (8, 8a, 8b) er anbragt til at rumme en vertikal stak af opbevaringsbeholdere (2), og

hoveddelen af beholderopbevaringsstrukturen (15) falder sammen med positioner på køretøjsbæreren (14), hvor bæreskinne (13) krydser hinanden, og

10 - en beholderløfteanordning (50) anbragt til at transportere en køretøjsleveret opbevaringsbeholder (2) i en retning vinkelret på køretøjsbærerens (14) laterale plan mellem køretøjsbæreren (14) og en afleveringsstation (60).

11. Opbevaringssystem (3) ifølge krav 10, **kendetegnet ved, at** mindst nogle af bæreskinne (13) anbragt ved det ydre grænseområder (17, 18) af køretøjsbæreren (14) danner ydre føringsnet med reduceret middeltværsnit sammenlignet med middeltværsnittet af de resterende føringsnet i køretøjsbæreren (14).

12. Opbevaringssystem (3) ifølge krav 11, **kendetegnet ved, at** det reducerede middeltværsnit af de ydre føringsnet er ca. det halve af middeltværsnittet af de resterende føringsnet i køretøjsbæreren (14).

20 13. Opbevaringssystem (3) ifølge krav 11 eller 12, **kendetegnet ved, at** størrelsen af de ydre føringsnet kun er reduceret langs den anden retning (Y) af køretøjsbæreren (14).

DRAWINGS

Drawing

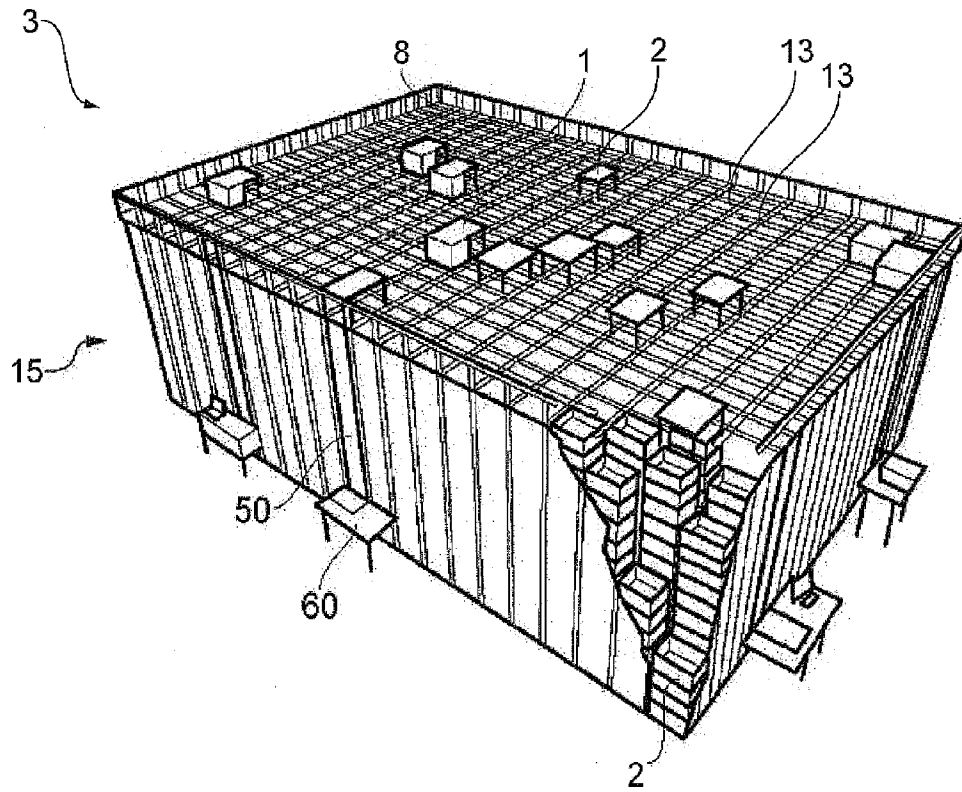

FIG. 1(Prior Art)

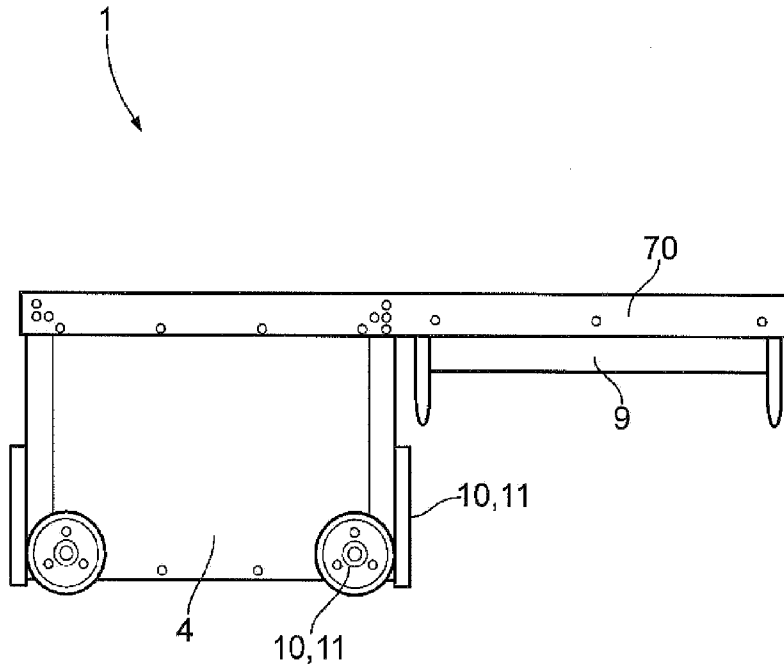

FIG. 2 (Prior Art)

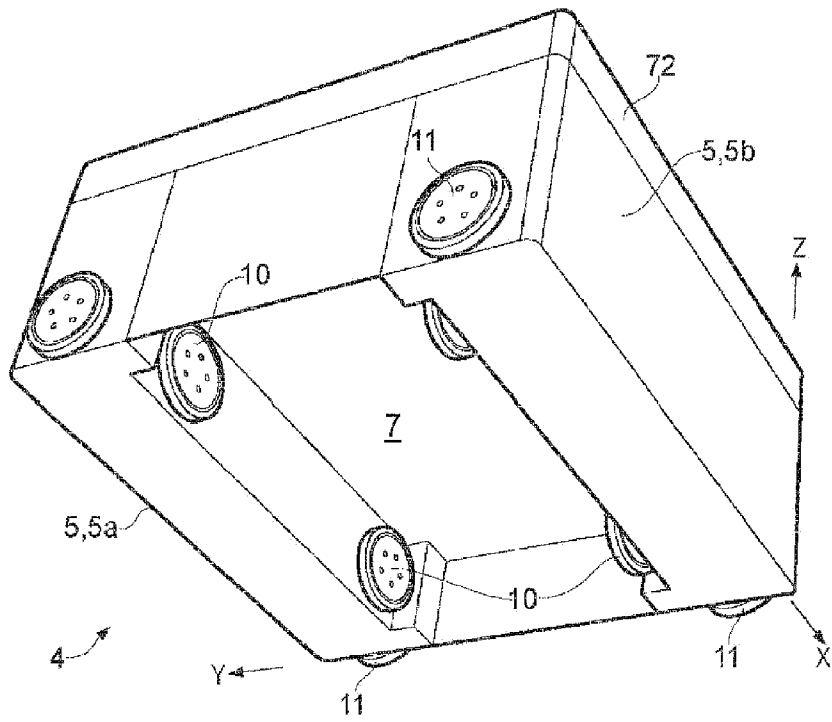

FIG. 3

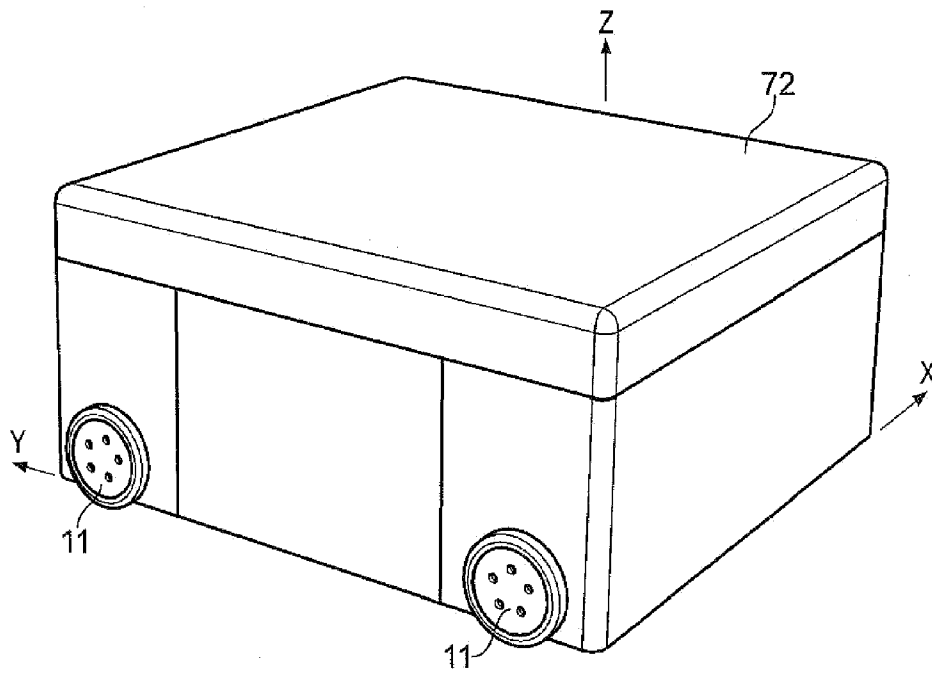

FIG. 4

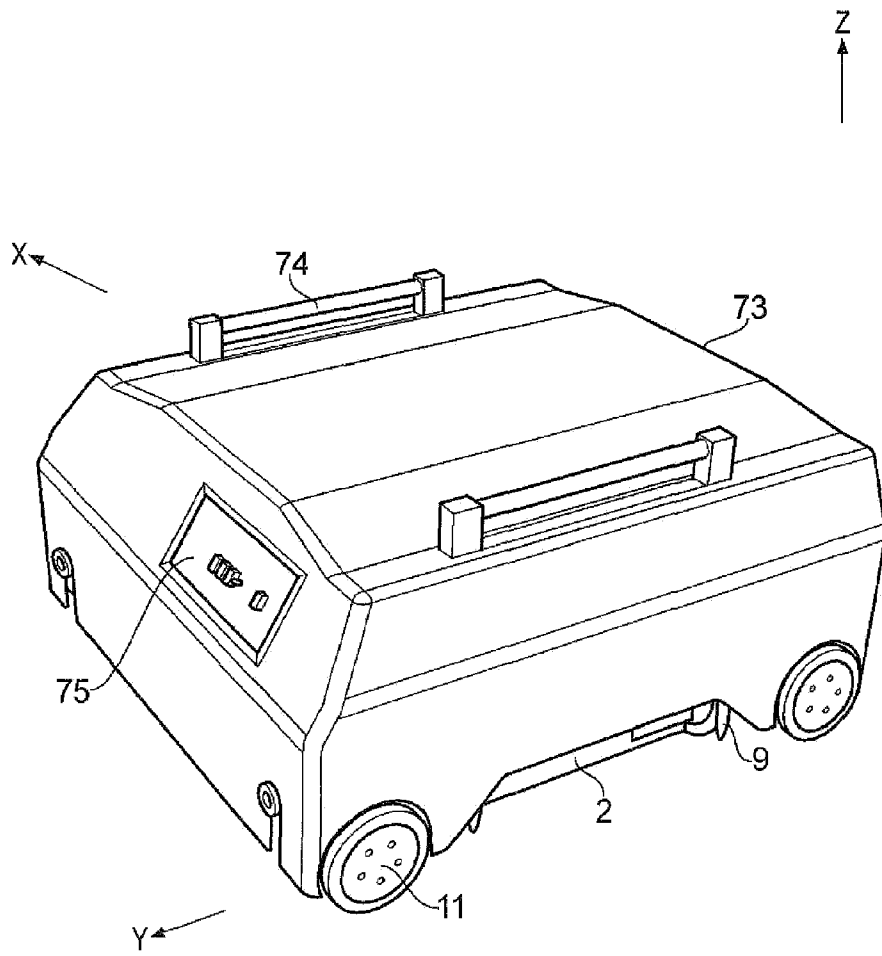

FIG. 5

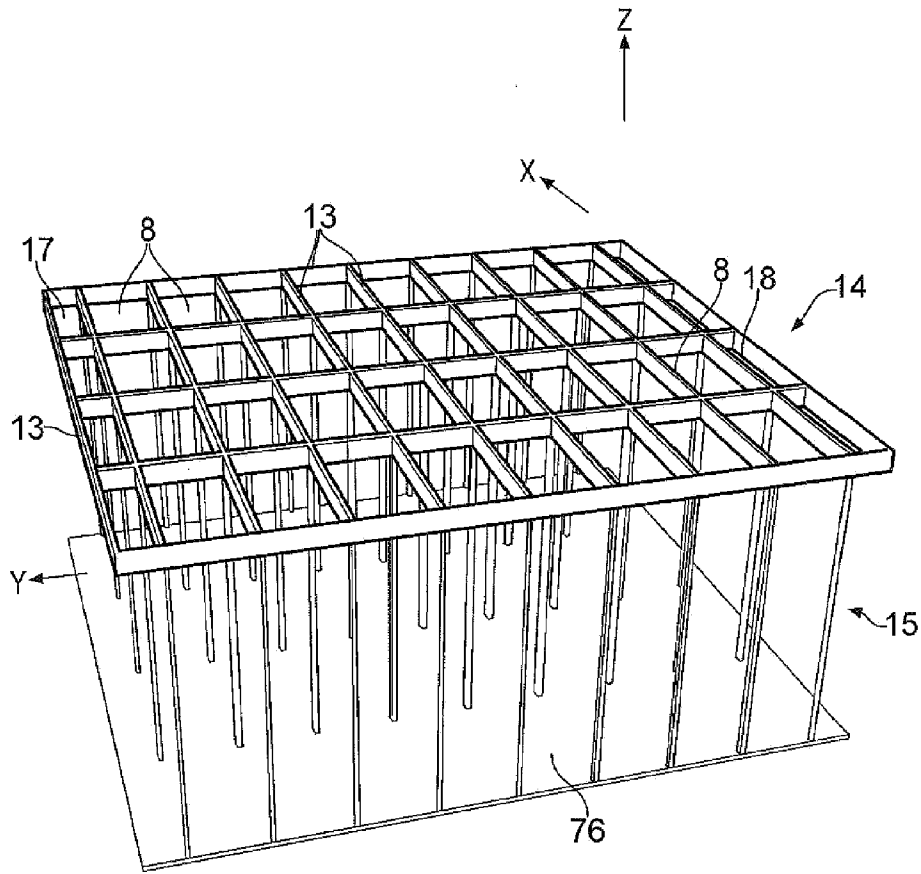

FIG. 6

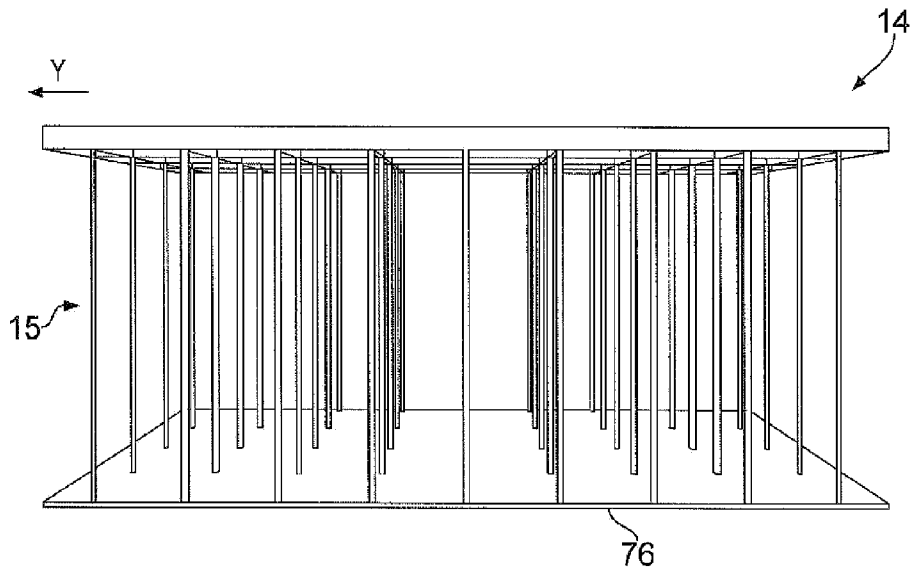

FIG. 7

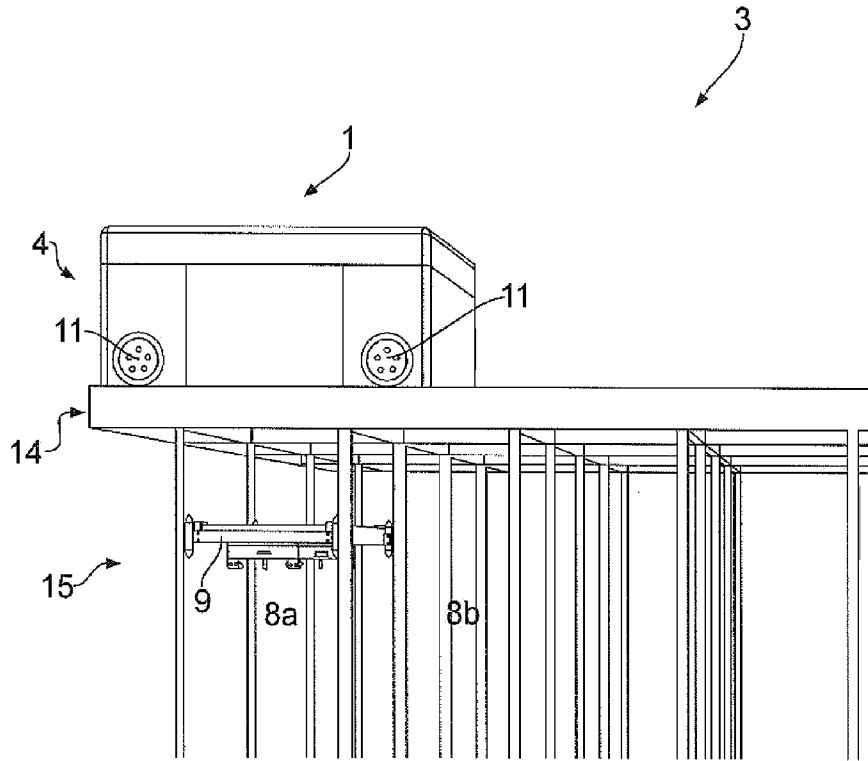

FIG. 8

