

(No Model.)

3 Sheets—Sheet 1.

S. TUTTLE.
ROLLER PRESS.

No. 522,243.

Patented July 3, 1894.

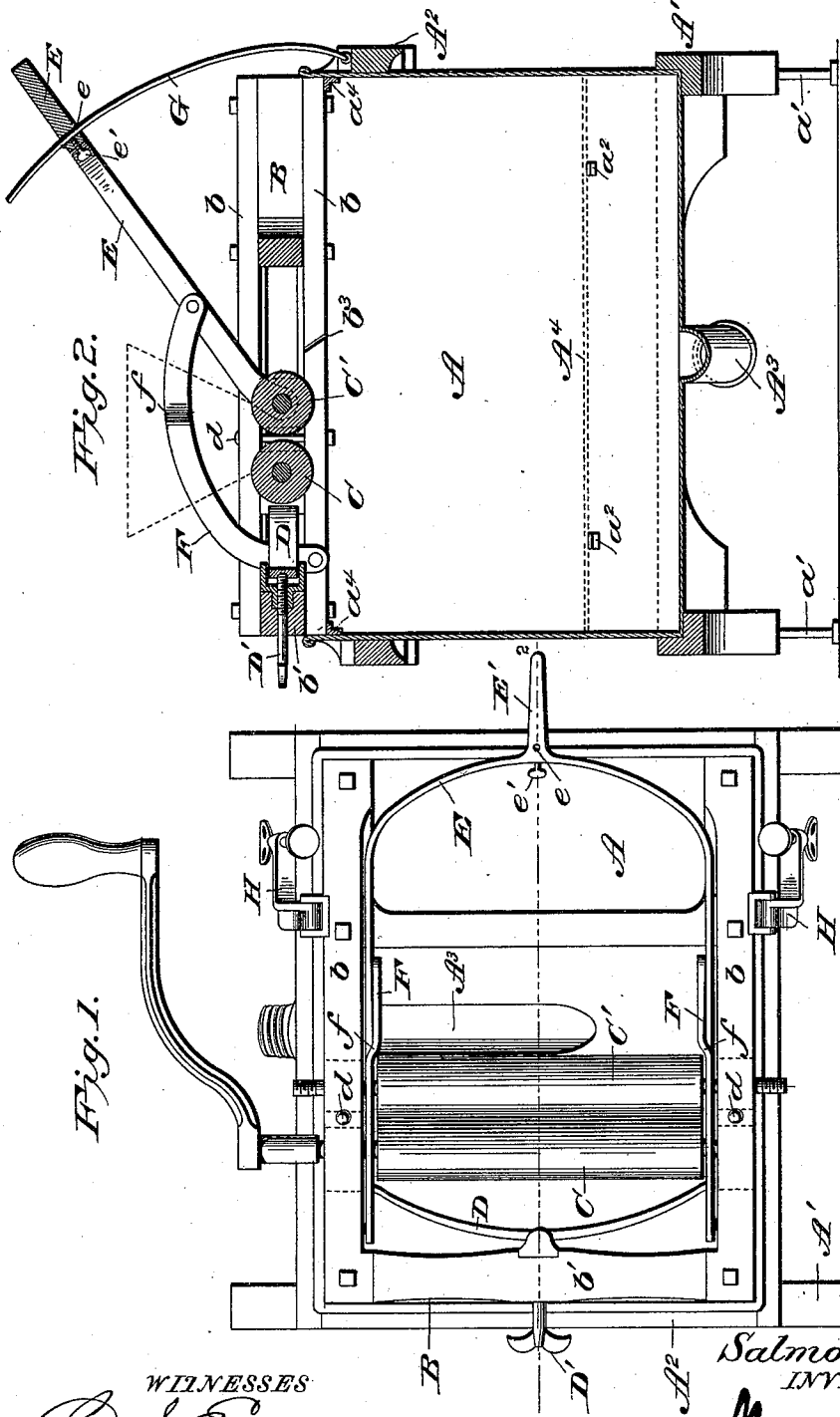

Fig. 1.

Fig. 2.

WITNESSES

G. S. Elliott.
M. Johnson

Salmon Tuttle
INVENTOR

by *[Signature]* Attorney

(No Model.)

3 Sheets—Sheet 2.

S. TUTTLE.
ROLLER PRESS.

No. 522,243.

Patented July 3, 1894.

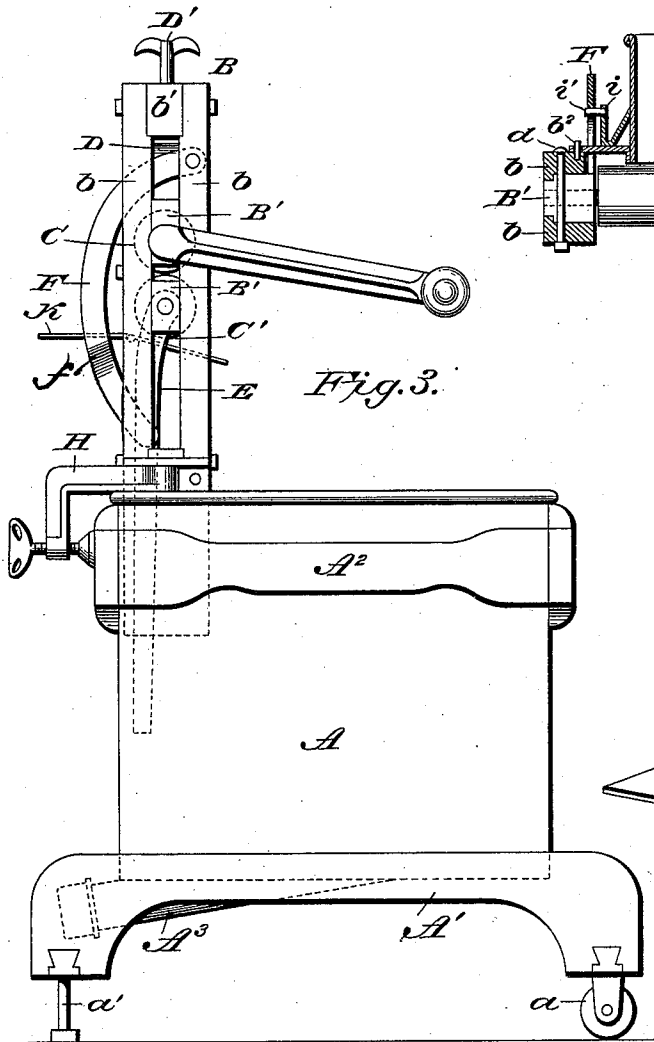

Fig. 4.

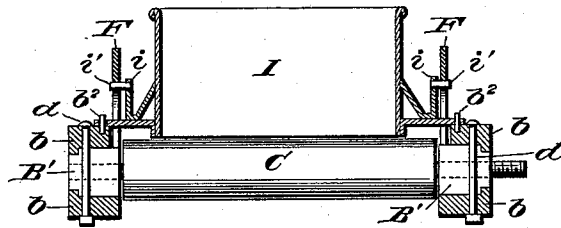

Fig. 5.

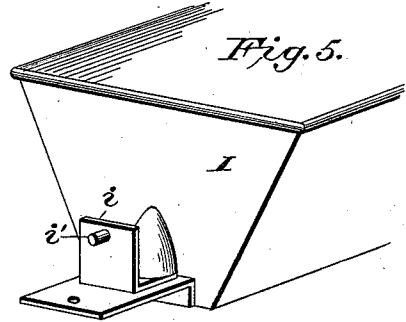
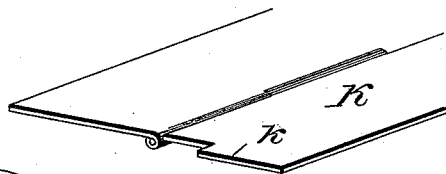

Fig. 6.



WITNESSES
G. S. Elliott,
M. Johnson

Salmon Tuttle
 INVENTOR

by *[Signature]*
 Attorney

(No Model.)

3 Sheets—Sheet 3

S. TUTTLE.
ROLLER PRESS.

No. 522,243.

Patented July 3, 1894.

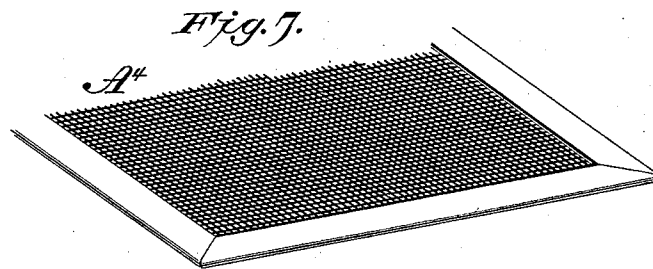
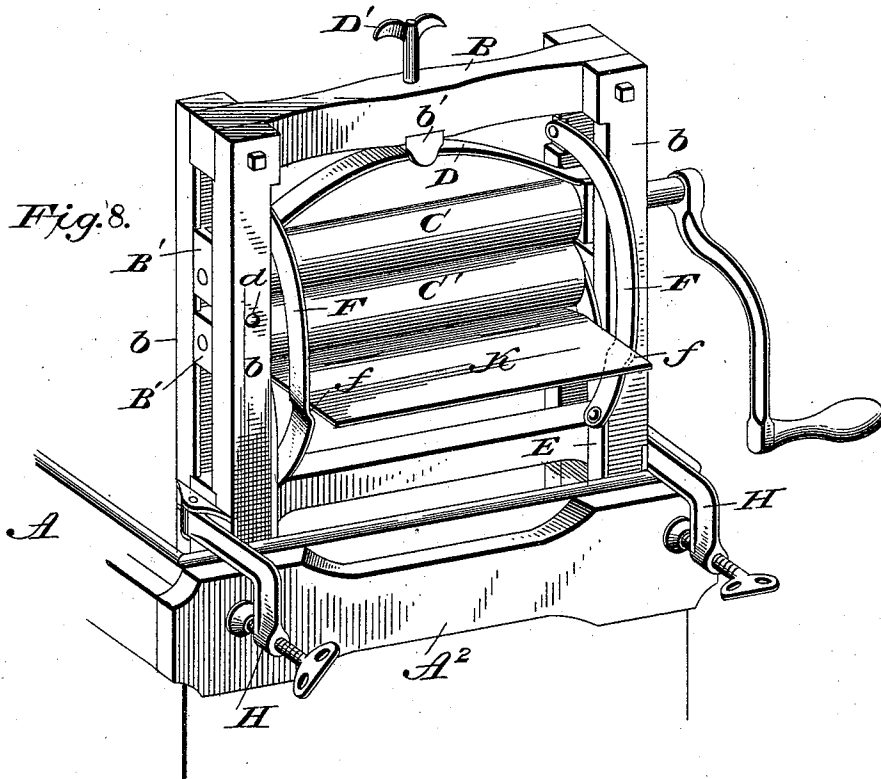

WITNESSES
G. S. Elliott.
M. Johnson.

Salmon Tuttle,
 INVENTOR

by [Signature] Attorney

UNITED STATES PATENT OFFICE.

SALMON TUTTLE, OF CALDWELL, KANSAS, ASSIGNOR TO IDA LEA TUTTLE,
OF SAME PLACE.

ROLLER-PRESS.

SPECIFICATION forming part of Letters Patent No. 522,243, dated July 3, 1894.

Application filed February 1, 1894. Serial No. 498,804. (No model.)

To all whom it may concern:

Be it known that I, SALMON TUTTLE, a citizen of the United States of America, residing at Caldwell, in the county of Sumner and State of Kansas, have invented certain new and useful Improvements in Roller-Presses; and I do hereby declare the following to be a full, clear, and exact description of the invention, such as will enable others skilled in the art to which it appertains to make and use the same, reference being had to the accompanying drawings, and to letters of reference marked thereon, which form a part of this specification.

The object of this invention is to provide a roller-press of improved construction which may be advantageously used for a number of different purposes.

In the accompanying drawings, Figure 1 is a plan view showing my improved roller-press placed in such a position in the tub or receptacle so that it may be used as a mop-wringer. Fig. 2 is a sectional view taken on the line 2—2 of Fig. 1. Fig. 3 is a side elevation showing the organization of the parts as a wringer. Figs. 4 and 5 are detail views of the hopper, and Fig. 6 is a detail perspective view of the deflector-plate employed when the device is used as a wringer. Fig. 7 is a detail view showing a part of the foraminous plate which is supported within the receptacle or tub, and Fig. 8 is a view showing the application of the deflector-plate to the frame.

A designates a receptacle which is preferably made of sheet-metal and is supported upon a base frame A' which is provided with caster-wheels a and supporting legs a' , so that when one side of the receptacle is raised it can be wheeled from place to place. The upper part of the receptacle is braced by a frame A², as shown. The receptacle is provided with an outlet-spout A³ which is adapted to be closed by a screw-cap, and interiorly is provided with ledges or rests a^2 upon which a foraminous plate A⁴ is adapted to rest; there are also ledges or rests a^4 at the corners of the receptacle near the upper edge upon which the roller-frame rests when placed in the position shown in Figs. 1 and 2.

B designates the roller-frame the side

pieces bb of which have placed between them movable blocks B' in which are journaled rollers C and C'. The blocks through which the shaft of the roller C passes are limited in their movement in one direction by bolts dd which pass through the side pieces of the roller frame, and upon these blocks a spring D bears the tension of which is adjusted by means of a set-screw D' which passes through a threaded aperture in the cross-piece b' of the roller-frame. The shaft of the roller C' passes through the ends of a yoke-lever E and is journaled in the movable blocks B', the yoke-lever being shaped into a handle E'; this arrangement locates the ends of the yoke-lever between the ends of the roller and side pieces of the roller-frame.

F F designate links which are pivoted to the members of the yoke-lever E and to the side pieces of the roller-frame between the cross-piece b' thereof and the roller C. These links are slightly bent, as at f , so that they may be pivoted to the inner side of the members of the yoke-lever, and said bends also serve as rests for the deflector-plate shown in Fig. 6, when the same is used. The handle of the yoke-lever is provided with an aperture, e , and with a set-screw e' , and through the aperture a rod G is adapted to be passed one end of which engages an eye at the upper part of the receptacle, and by means of this rod and the set-screw the yoke-lever can be set in an adjusted position.

To the side pieces of the roller-frame are pivotally attached clamps H H which can be used to hold the roller-frame in a vertical position in the receptacle or swung to one side to hold the roller-frame upon the receptacle in the position shown in Fig. 3, with the yoke-lever clamped between the side pieces of the roller-frame and side of the receptacle.

The side pieces of the roller-frame B are provided with projecting pins b^2 which are adapted to engage apertures in flanges projecting from the ends of a hopper I. The flanges are provided with uprights, i , having outwardly-projecting pins i' with which the curved links F are adapted to engage when the yoke-lever is lowered to its fullest extent and retains the hopper securely in place.

The inner side pieces of the roller frame

are provided with inclined grooves or recesses b^3 in which are adapted to be placed a deflector-plate K made up of two pieces hinged to each other, one piece having a projecting portion k at each end which rest in the inclined recesses while the ends of the other piece rest upon the offsets or bends in the links F, when the device is used as a wringer as shown in Fig. 3; this arrangement leading the water which is wrung from the clothes into the receptacle A.

When the device is used as a mop-wringer the roller-frame is placed in a horizontal position upon the ledges a^4 of the receptacle A, and by raising the yoke-lever the rollers C and C' can be separated and the mop placed between them, then by depressing the yoke-lever the roller C' will be moved toward the roller C and by turning one of the rollers the water can be wrung from the mop, the pressure of the rollers upon the mop being regulated by the pressure exerted upon the yoke-lever.

In Fig. 2, where the device is shown applied as a fruit press the roller-frame is placed upon the receptacle in the same position as for a mop-wringer, but in connection therewith I use the hopper shown in Figs. 4 and 5. In pressing such fruit as have stones, seeds or skins and in which it is desired to have the rollers spaced at a predetermined distance from each other I use the rod G for clamping the yoke-lever at an angle as shown in Fig. 2, and also place in the receptacle a foraminous or reticulated screen plate A^4 ; and in pressing cherries, for instance, the fruit is placed in the hopper and the yoke-lever adjusted; the rollers may then be turned to press the stones from the cherries, the pulp and stones falling upon the plate A^4 , after which the yoke-lever can be adjusted to bring the rollers closer together and the pulp passed through them to extract all the juice therefrom.

The outer ends of the curved links F F are pivoted to the side bars of the frame between which the rollers C C' are journaled and the other ends are pivoted to the side pieces of the lever E, said lever being pivoted upon the journal of the roller C'; thus providing a construction in which the pivotal points of connection can be brought into line with each other, so that when the lever E is moved to its fullest extent to bring the rollers close together the lever will be locked against movement when pressure is applied to the rollers, the parts being positioned as shown in Fig. 3. This means of locking the roller against movement is utilized in extracting the juice from fruit and when the device is used as a clothes-wringer.

When the device is used as a wringer for light articles it is attached to the receptacle as shown in Fig. 3 and the deflector-plate used in connection therewith; but in wringing heavy articles, as carpets, blankets, &c., the deflector-plate is not used and the roller-

frame is turned round so that the yoke-lever may be used to adjust the roller C', the clamps being swung upon their pivots to engage the frame A^2 of the receptacle.

It will be observed that the rollers C and C' are turned by a crank-handle having a projecting portion which engages one of the shafts, and for convenience I provide one of the rollers with a shaft which extends beyond each side of the roller-frame so that the device may be used by either a right or left-handed person.

Having thus described my improved roller-press and recited a number of uses to which the same may be put, I will now proceed to claim my invention, which consists—

1. In a roller-press, the combination with a frame having rollers movable therein to and from each other, of a yoke-lever pivoted to the supporting shaft of one of the movable rollers, and curved links pivoted to the yoke-lever and to the roller-frame, the curved links having offsets or bent portions f , together with a deflector-plate supported upon the bent portions of the curved links, substantially as shown and described.

2. In a roller-press, the combination, of the rollers C and C' movably mounted in a frame, one of the rollers being connected to a yoke-lever, curved links F F pivoted to the yoke-lever and to the frame, a hopper adapted to rest upon the frame above the rollers, said hopper having projections with which the curved links engage when the lever is lowered, substantially as shown and for the purpose set forth.

3. In combination with a roller-carrying frame and rollers provided with means for adjusting said rollers to or from each other, the roller carrying frame having upwardly-projecting pins b^2 , of a hopper having flanges with perforations through which the pins pass and upwardly-projecting portions with outwardly-projecting pins with which links F F engage for holding the hopper securely in place upon the roller-frame, substantially as shown and for the purpose set forth.

4. In a roller-press, the combination, of a roller-frame having movable rollers one of which is attached to a yoke-lever, curved links F F having offsets, said links being pivoted to the roller-frame and to the yoke-lever, inclined grooves or recesses b^3 in the side pieces of the roller-frame, and a two-part plate K one part of which is adapted to engage with the inclined grooves or recesses and the other rest upon the offsets of the curved links, substantially as shown and described.

In testimony whereof I affix my signature in presence of two witnesses.

SALMON TUTTLE.

Witnesses:

SAM SWAYER,
D. W. BALL.