

19



Europäisches Patentamt
European Patent Office
Office européen des brevets



11 Publication number:

0 362 924 B1

12

EUROPEAN PATENT SPECIFICATION

45 Date of publication of patent specification: **11.05.94** 51 Int. Cl.⁵: **C25D 7/06**

21 Application number: **89202386.2**

22 Date of filing: **21.09.89**

The file contains technical information submitted after the application was filed and not included in this specification

54 **Apparatus for the continuous electrolytic treatment of wire-shaped objects.**

30 Priority: **06.10.88 BE 8801152**

43 Date of publication of application:
11.04.90 Bulletin 90/15

45 Publication of the grant of the patent:
11.05.94 Bulletin 94/19

64 Designated Contracting States:
BE DE ES FR GB IT LU NL

56 References cited:
US-A- 2 229 423
US-A- 2 708 181

73 Proprietor: **N.V. BEKAERT S.A.**
Bekaertstraat 2
B-8550 Zwevegem(BE)

72 Inventor: **Catteeuw, Mario**
Albertstraat 25
B-8550 Zwevegem(BE)
Inventor: **Cosaert, Pierre**
Lode de Boningestraat 34
B-8500 Kortrijk(BE)

EP 0 362 924 B1

Note: Within nine months from the publication of the mention of the grant of the European patent, any person may give notice to the European Patent Office of opposition to the European patent granted. Notice of opposition shall be filed in a written reasoned statement. It shall not be deemed to have been filed until the opposition fee has been paid (Art. 99(1) European patent convention).

Description

The invention relates to an apparatus for the continuous electrolytic treatment of wire-shaped objects such as e.g. filaments, yarns, cables or strip-shaped bands or ribbons. This treatment can be either a coating treatment or a pickling treatment.

The continuous electrolytic galvanizing of wire-shaped objects in a continuous apparatus whereby the wires are conducted nearly horizontally past a succession of cathodes and inert anodes is known from U.S. patent 2.695.269. The current-transmitting sliding-contact points of the cathodes are located just below the electrolyte bath surface. The anodes plates are completely immersed in the electrolyte. This apparatus makes a relatively fast electrodeposition possible. However, this set-up of the cathodic supporting arms with downwardly extending contact fingers above the bath is rather cumbersome and not very practical. Indeed, this set-up hinders an easy accessibility of the upper bath surface. Moreover, in the course of time, salt crystals from the bath precipitate on the supporting arms and the cathode fingers above the bath, which entails frequent cleaning and maintenance. Besides, the requirement of an even and constant sliding contact between the cathode fingers and the wires is hard to fulfil. The cathode fingers have as it were the tendency to vibrate or dance up and down on the wires as a result of which there are frequent contact interruptions which result in sparking and consequently in an irregular deposition quality.

Similar arrangements with downwardly extending cathode carrying hangers respectively contactors are also known from U.S. patent 2.229.423 respectively from U.S. patent 2.708.181. The object of the invention is now to overcome these drawbacks by immersing the supporting and current-carrying arms of the successive cathodes in the electrolyte. This precludes the formation of salt crystals and the maintenance that it entails. Besides, this set-up has the added advantage that the immersed cathode can cool down more easily. Indeed, as the wires have a relatively high running speed through the installation, high current densities are to be used which can cause the cathodes to heat up considerably. Cooling in liquid and circulating electrolyte is much more effective than air cooling such as for contact fingers or contact rollers placed above the bath or at the bath entry and exit, respectively. The accessibility of the bath surface that is markedly improved in accordance with the invention is particularly advantageous upon starting the apparatus when a new series of wires is to be pulled through from entry (pay-off) to exit (take-up unit). It also improves the surveyability of

the installation, which makes process control easier for the operator.

It is therefore an object of the invention to provide an apparatus for the continuous electrolytic treatment of wire-shaped objects, the latter being conducted predominantly horizontally via suitable transport means through an electrolyte bath past a succession of anodes and cathodes. In the apparatus, the objects follow a zigzag path of travel in sliding contact with the successive current-transmitting electrodes connected to one and the same pole of the power source. The electrodes, i.e. their parts assuring the sliding-contact, and the elements supporting them are immersed in the electrolyte bath. Actually, the apparatus comprises an electrode arrangement as stated in the appended claims.

In addition to the aforementioned advantages, the application of the zigzag path of travel over the sliding contacts of said electrodes precludes the tendency to sparking which occurs with state-of-the-art electrode fingers. Indeed, the considerable transport tension on the wires between pay-off and take-up unit guarantees a constant and even contact of the wire with the electrodes at the peaks and valleys of the zigzag path of travel. It follows that operational reliability and the assurance of a constant process quality are obtained via a strong simplification of the prior art apparatuses.

If the treatment apparatus is an electroplating line, said electrodes with sliding contacts will be connected as cathodes. The wires conducted against the sliding contacts then constitute the cathode in the coating line and the positive ions of the metal (e.g. zinc) to be applied will precipitate on them from the electrolyte in the path of travel at the anodes located opposite the wires.

For a treatment apparatus in the form of a pickling apparatus, said electrodes will be connected as anodes. The metal coating to be removed from the passing wires then dissolves in the electrolyte and deposits on the stationary cathodes at the path of travel of the wire near these cathodes.

A coating apparatus as embodiment of the invention will hereinafter be illustrated with reference to the accompanying figures.

Figure 1 is a vertical section through the set-up of successive electrodes in the electrolyte bath of the coating line.

Figure 2 represents a view from above of the apparatus with a zigzag path of travel for the series of wires.

Figure 3 is a cross-section through an inert anode plate of the apparatus as electroplating line.

Figure 4 shows a vertical section through another electrode set-up for a zigzag path of trav-

el.

The electrolysis apparatus in accordance with figure 1 basically comprises an elongate tank or channel 1 as electrolyte bath. This bath 1 is filled with a suitable electrolyte up to level 3 so that both the anodes 4 and the cathodes 5 are immersed in it. The cathode pins 5 are fixed on successive supporting arms 6, 7, 8 (e.g. of copper). The successive anode sections 9, 10 are mounted between said supporting arms. Said sections comprise the supporting arms 11 (e.g. of copper) for the anode plates 4, 12. These are e.g. inert lead anodes. The respective supporting arms for cathodes and anodes are connected to the current-supply bars 13 and 14. The electrode-supporting parts (6, 7, 8) of these arms are immersed with the electrodes 5 in bath 1 under the bath surface 3.

In order to realize a good electrolysis efficiency, the electrolyte can be continuously circulated by means of pumps (not shown) and through the bores 16 in the anode plates towards the surface level 3 of the bath 1. The circulation increases the turbulence in the bath, which increases the electrolysis efficiency.

The wire-shaped objects 2 to be coated are now continuously conducted past a succession of anodes 4, 12 and cathode supports 6, 7, 8 below the electrolyte surface 3. In the process, the wires drag against the pins 5 fixed on the respective current-carrying supporting arms 6, 7, 8 as a result of which they are connected as cathode, tracing a horizontal zigzag path of travel as shown in figure 2. So, the successive peaks and valleys of the zigzag path of travel are located at these pins 5. The electrodes themselves comprise a highly conductive but preferably also wear-resistant metal alloy, e.g. tungsten carbide at the sliding contacts at the zigzag peak/valley positions.

In each space between two consecutive peak/valley positions, the wires come in the vicinity of the inert anode plates 4, 12 where the desired metal deposition from the bath 1 takes place. The anode plates 4, 12 can be designed flat but will preferably comprise channel-shaped recesses 15 (as sketched in figure 3) at the path of travel of the wires 2 between two consecutive cathode pins 5. This way, a more even metal deposition is obtained over the whole wire circumference.

Figure 4 schematically shows another nearly horizontal zigzag path of travel for the wires 2. An insulated (ceramic) counterpressure bar 17 or 18 is mounted near each cathode-supporting arm 6 or 7 respectively. These can e.g. be tilted upwards out of and away from the bath for the purpose of making the bath surface easily accessible when starting the apparatus for a new series of wires. The cathode-supporting arms 6, 7 are each coated with a wear-resistant layer 19 as sliding contact for

the transmission of current to the wires.

Claims

- 5 1. Apparatus for the continuous electrolytic treatment of wire-shaped objects (2) comprising an electrolyte bath (1) and means for conducting the objects (2) predominantly horizontally through the bath (1) past a succession of anodes and cathodes, wherein the objects (2) follow a zigzag path of travel in sliding contact with the successive current-transmitting electrodes (5, 19) that are immersed in the electrolyte and connected to one and the same pole (14) of the power source characterized in that the supporting arm parts (6, 7, 8) for said electrodes, each extending horizontally across the bath, thereby carrying a number of said electrodes (5, 19), are also immersed under the surface (3) of the electrolyte bath.
- 10
- 15
- 20 2. Electroplating apparatus in accordance with claim 1, characterized in that said electrodes (5, 19) are connected as cathodes.
- 25 3. Electrolytic pickling apparatus in accordance with claim 1, characterized in that the electrodes (5, 19) are connected as anodes.
- 30 4. Apparatus in accordance with claim 1, characterized in that the electrodes (5, 19) comprise a wear-resistant metal alloy at the sliding contacts.
- 35 5. Apparatus in accordance with claim 2, characterized in that the successive anodes (4, 12) between each pair of cathodes (6, 7, 8) comprise channel-shaped recesses (15) at the paths of travel of the objects.
- 40 6. Apparatus in accordance with claim 5, characterized in that the anodes are inert.

Patentansprüche

- 45 1. Vorrichtung zur kontinuierlichen elektrolytischen Behandlung drahtförmiger Objekte (2), umfassend ein Elektrolytbad (1) und Mittel zum Führen der Objekte (2) überwiegend horizontal durch das Bad (1) an einer Aufeinanderfolge von Anoden und Kathoden vorbei, wobei die Objekte (2) einem Zickzack-Laufweg in Gleitkontakt mit den aufeinanderfolgenden stromübertragenden Elektroden (5, 19) folgen, welche in das Elektrolyt eingetaucht und mit ein und demselben Pol (14) der Stromquelle verbunden sind, dadurch gekennzeichnet, daß die Haltearmteile (6, 7, 8) für die Elektroden, die
- 50
- 55

sich jeder horizontal quer zum Bad erstrecken und dabei eine Anzahl der Elektroden (5, 19) tragen, ebenfalls unter die Oberfläche (3) des Elektrolytbads eingetaucht sind.

2. Elektroplattier Vorrichtung nach Anspruch 1, dadurch gekennzeichnet, daß die Elektroden (5, 19) als Kathoden angeschlossen sind. 5
3. Elektrolytische Beizvorrichtung nach Anspruch 1, dadurch gekennzeichnet, daß die Elektroden (5, 19) als Anoden angeschlossen sind. 10
4. Vorrichtung nach Anspruch 1, dadurch gekennzeichnet, daß die Elektroden (5, 19) eine verschleißfeste Metallegierung an den Gleitkontakten umfassen. 15
5. Vorrichtung nach Anspruch 2, dadurch gekennzeichnet, daß die aufeinanderfolgenden Anoden (4, 12) zwischen jedem Paar von Kathoden (6, 7, 8) kanalförmige Ausnehmungen (15) bei den Laufwegen der Objekte umfassen. 20
6. Vorrichtung nach Anspruch 5, dadurch gekennzeichnet, daß die Anoden inert sind. 25

Revendications

1. Appareil pour le traitement électrolytique continu d'objets (2) en forme de fil, comportant un bain d'électrolyte (1) et des moyens pour faire passer les objets (2), principalement horizontalement, à travers le bain (1) devant une succession d'anodes et de cathodes, appareil dans lequel les objets (2) suivent un chemin en zigzag en contact glissant avec les électrodes successives (5, 19) de transmission du courant qui sont immergées dans l'électrolyte et sont reliées à une seule et même borne (14) de la source d'énergie, appareil caractérisé par le fait que les pièces (6, 7, 8) formant bras supports pour lesdites électrodes, qui s'étendent chacune horizontalement en travers du bain, et portant un certain nombre de dites électrodes (5, 19), sont également immergées sous la surface (3) du bain d'électrolyte. 30
35
40
45
2. Appareil d'électroplacage selon la revendication 1, caractérisé par le fait que lesdites électrodes (5, 19) sont reliées en tant que cathodes. 50
3. Appareil de décapage électrolytique selon la revendication 1, caractérisé par le fait que les électrodes (5, 19) sont reliées en tant qu'anodes. 55

4. Appareil selon la revendication 1, caractérisé par le fait que les électrodes (5, 19) comportent un alliage métallique résistant à l'usure aux contacts glissants.

5. Appareil selon la revendication 2, caractérisé par le fait que les anodes successives (4, 12) situées entre chaque paire de cathodes (6, 7, 8) présentent des niches (15) en forme de canal sur les chemins des objets.
6. Appareil selon la revendication 5, caractérisé par le fait que les anodes sont inertes.

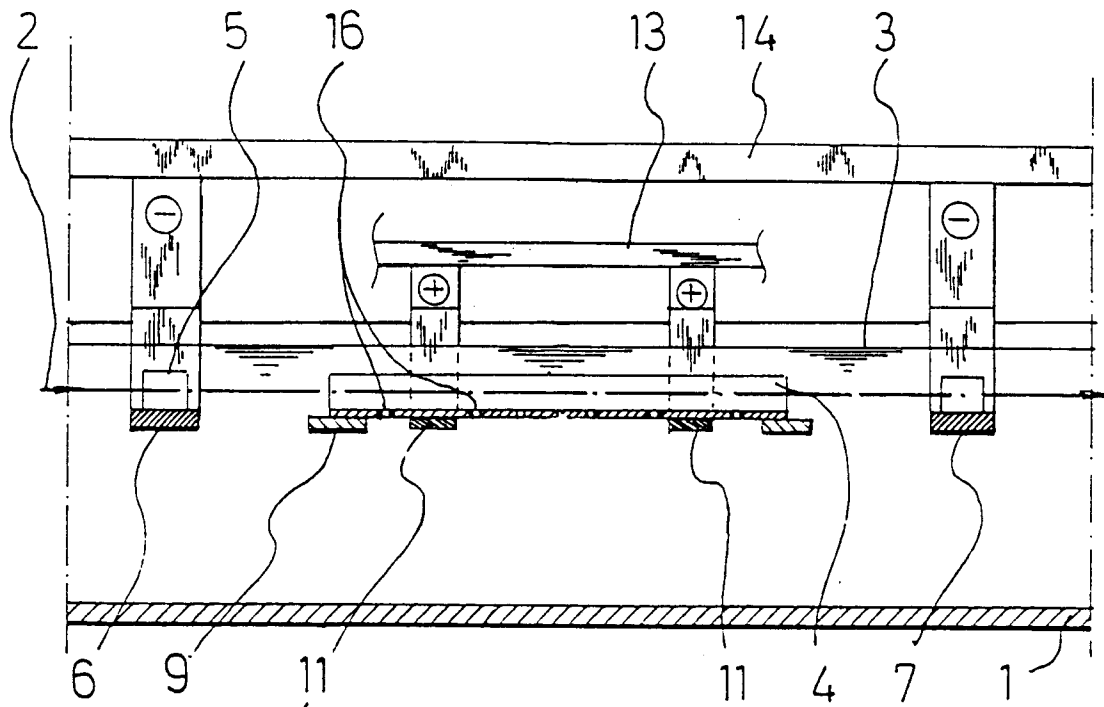

FIG. 1

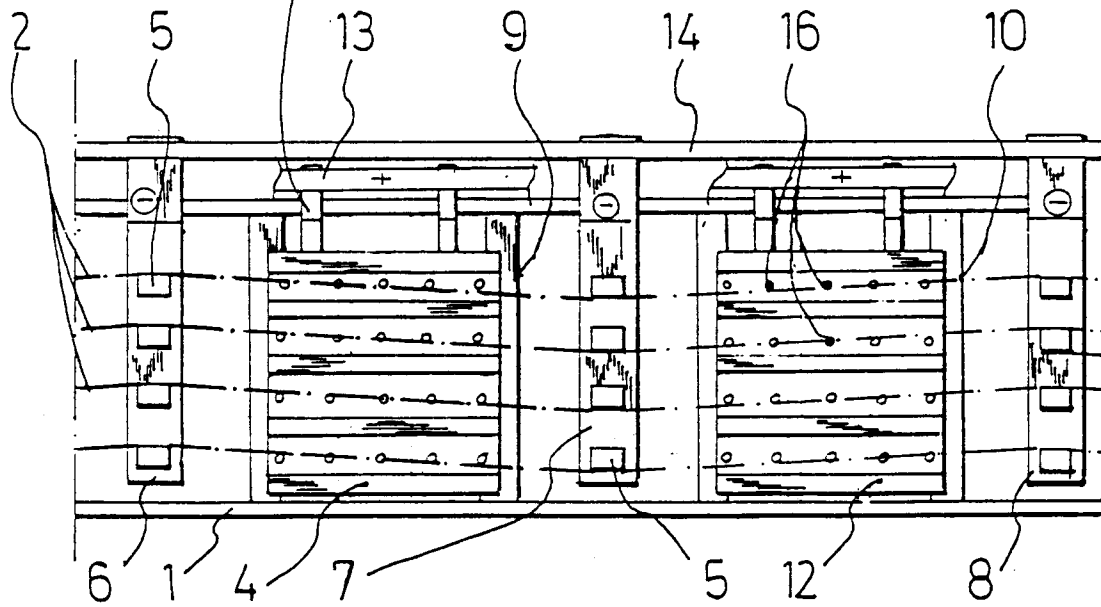

FIG. 2

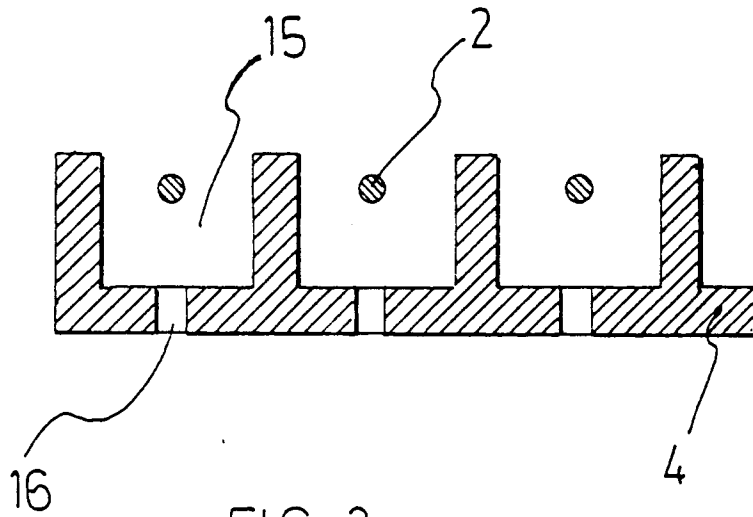

FIG. 3

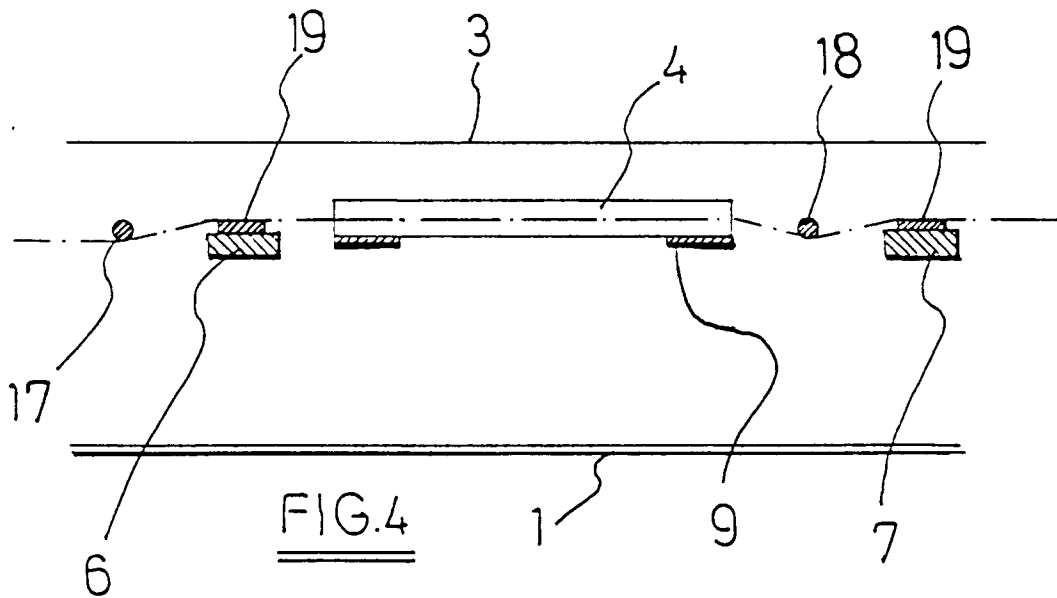

FIG. 4