

[54] CLOSURE FOR A LIGHT FIXTURE OR THE LIKE

3,309,565 3/1967 Clark et al240/51.11 X
3,370,164 2/1968 Green.....240/147

[72] Inventor: Ralph M. McFarlin, Pasadena, Tex.

Primary Examiner—Jerry W. Myracle
Attorney—Hyer, Eickenroht, Thompson & Turner

[73] Assignee: Esquire, Inc., New York, N.Y.

[22] Filed: June 15, 1970

[21] Appl. No.: 45,957

[57] ABSTRACT

[52] U.S. Cl.240/73 BC, 220/35
[51] Int. Cl.F21v 17/00
[58] Field of Search240/73 BC, 147, 146; 220/35

A closure for a light fixture or the like comprising a wall having an access opening therethrough and a window connected to the wall for swinging between a closed position in which it is over the opening and an open position to one side of the opening to provide access to the interior of the fixture.

[56] References Cited

UNITED STATES PATENTS

11 Claims, 6 Drawing Figures

2,639,368 5/1953 Pryne220/35 UX

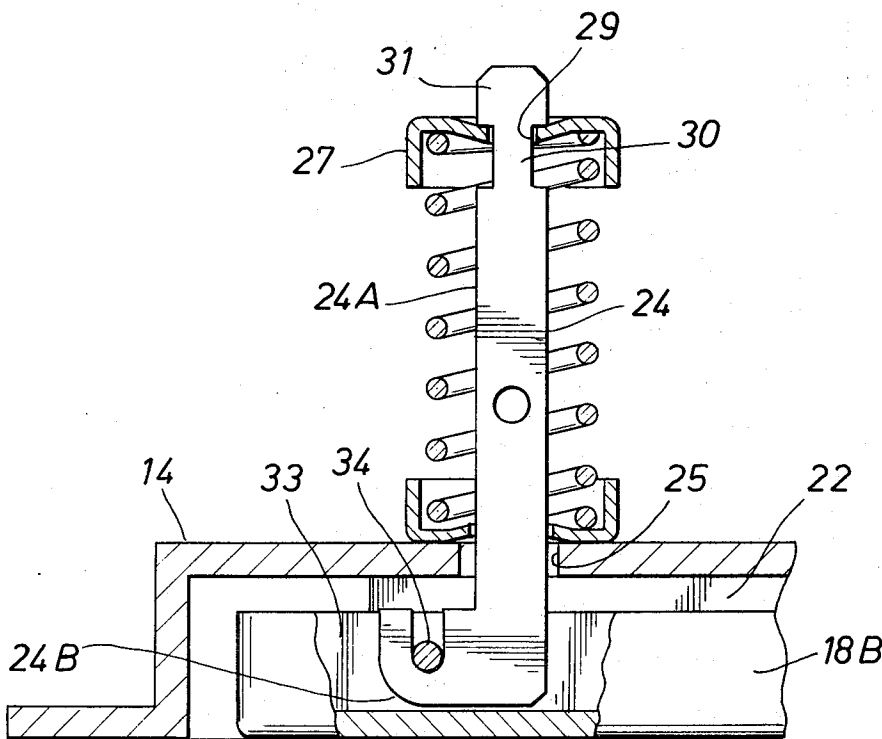

FIG. 1

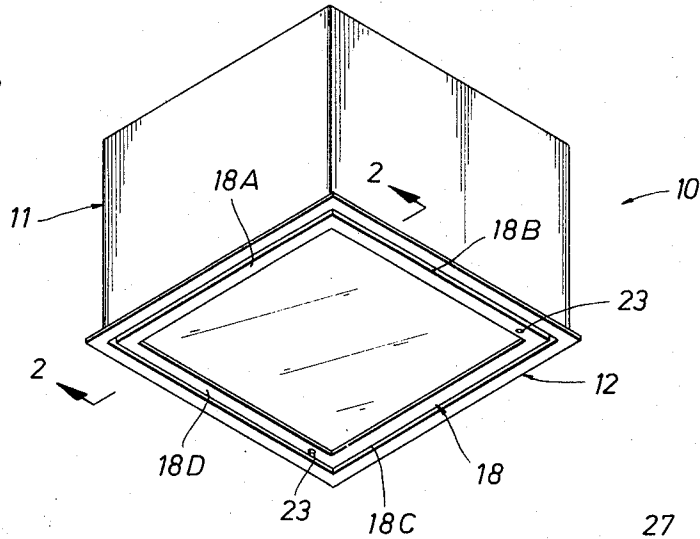

FIG. 2

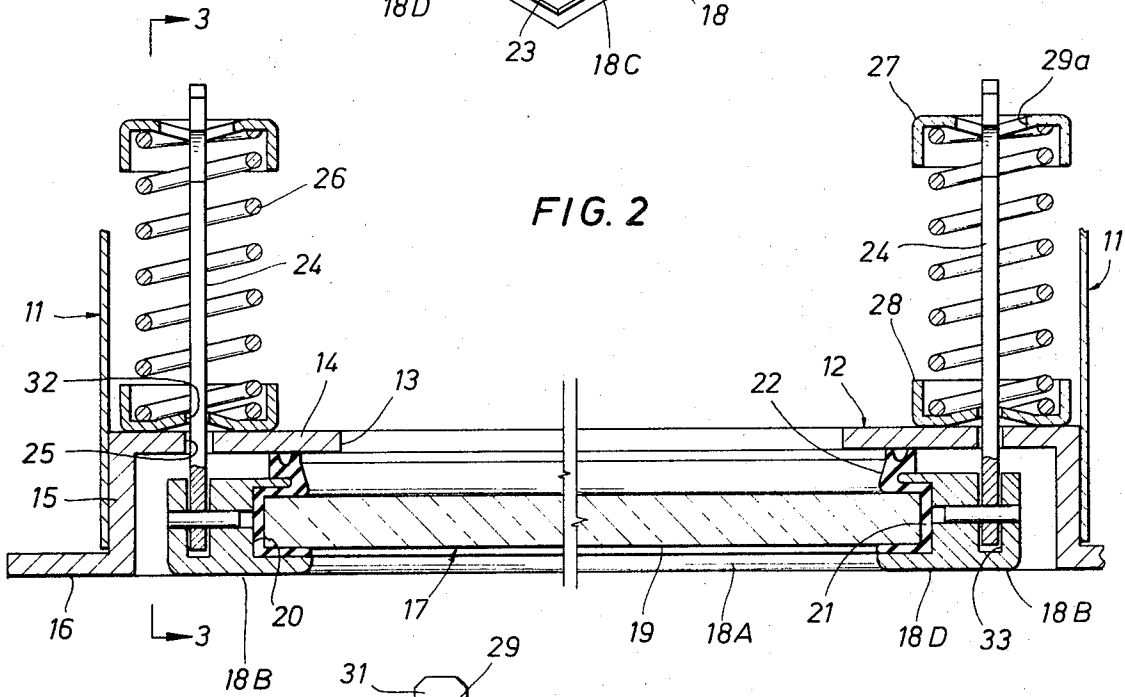
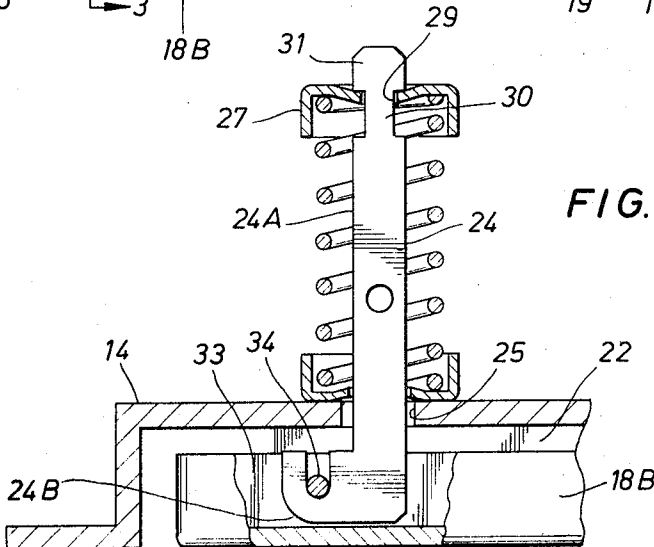

FIG. 3



Ralph M. McFarlin
INVENTOR

BY *Wyer, Eickenrodt,
Thompson & Turner*
ATTORNEYS

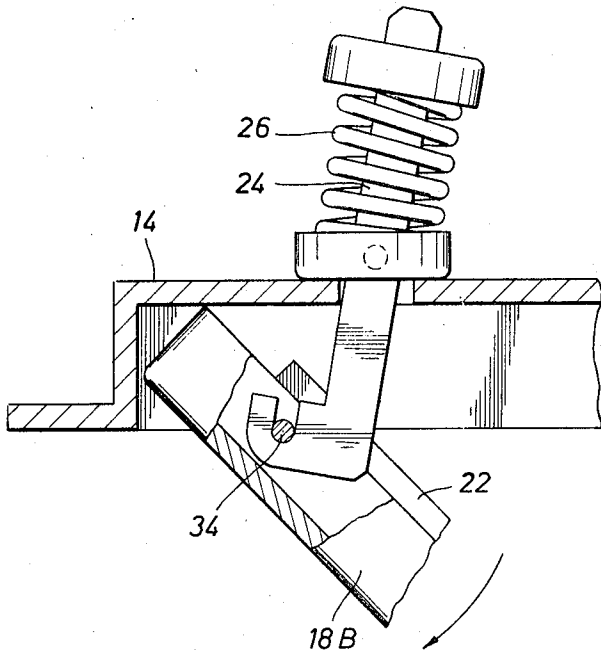

FIG. 4

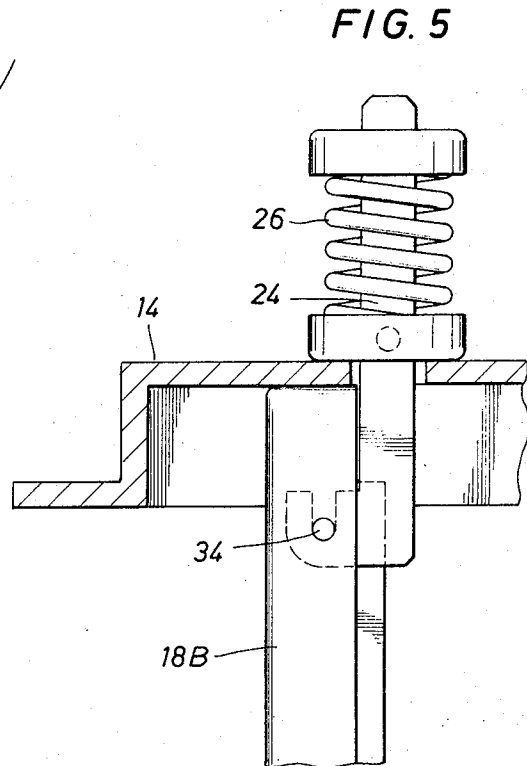

FIG. 5

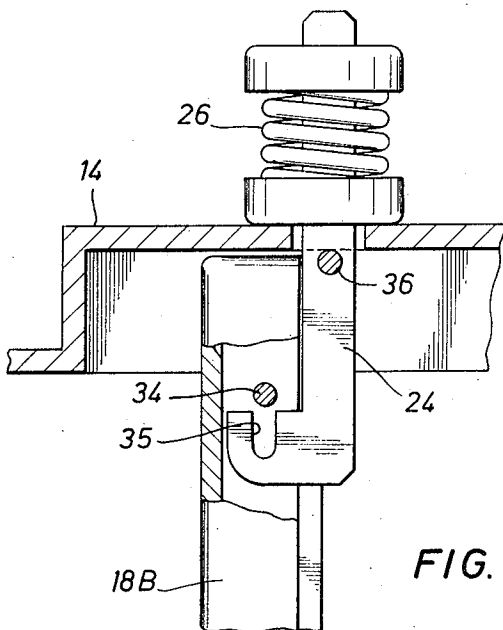

FIG. 6

Ralph M. McFarlin
INVENTOR

BY *Dyer, Eickenrodt,
Hompson & Turner*
ATTORNEYS

CLOSURE FOR A LIGHT FIXTURE OR THE LIKE

This invention relates to a closure for a light fixture or the like. More particularly, it relates to improvements in a closure of the type comprising a panel, such as a window, connected to a wall of a light fixture through which an opening to the interior of the fixture is provided for movement between a position closing the opening in dust proof fashion, and a position to one side of the opening for providing access to the interior of the fixture. A closure of this type is particularly useful as a window for an access opening into a ceiling mounted fixture wherein relamping and other operations must be performed from beneath the fixture.

One objection to the use of an ordinary hinge for connecting the window to the wall of a fixture of this type is that it may be seen from beneath the fixture, thus detracting to this extent from the appearance of the fixture. Also, the inherent tolerance in the ordinary hinge makes it difficult to maintain dust proof contact between the window and the wall when the window is closed.

It has also been proposed to connect the inner face of the window to the wall by various fasteners which urge the window to closed position with spring pressure, but enable the window to be lowered to open position when pulled downwardly against the spring pressure. As shown and described in U.S. Pat. No. 2,701,299, one of such fasteners may connect each of two opposite sides of the window to the wall to permit it to be lowered to a position below the access opening, and, then, upon detachment of one of the fasteners from one side of the window, to permit it to be swung about its connection to the other fastener to a position to one side of the opening.

One problem with the use of such a fastener for this purpose is that its spring pressure is not sufficient to maintain a dust-tight seal between the wall and window. This results at least in part from the fact that the fastener must be of sufficient length to permit the window to be lowered and then swung to one side. Another problem with their use is that the window is left dangling to one side of the access opening as the fixture is relamped or otherwise serviced.

An object of this invention is to provide a closure in which the panel is connected to the wall by parts which are concealed from view, is held in dustproof fashion against the wall when in closed position, and is held securely to one side of the access opening when in open position.

This and other objects are accomplished, by a closure which, in the illustrated embodiment of the invention, comprises a window having a frame and a pair of rods extending through the wall and pivotally connected to the inner face of the window frame near one side thereof. A spring means engages each rod on the inner face of the wall to urge the inner face of the window frame toward and into engagement with the outer face of the wall, in the closed position of the window, and the outer edge of the one side of the frame toward and into engagement with the outer face of the wall to one side of the wall opening, in the open position of the window.

As the window swings between open and closed positions, the spring means causes the corner of the outer edge of the one side of the frame to slide over the outer face of the wall. Since the rods are pivotally connected to the frame near its one side, the spring is required to change in length no more than that necessary for this camming action. That is, as compared with the prior closures above described, it's not necessary to considerably alter the length of the spring by raising and lowering the window as a whole. As a result, the spring means may comprise a coil spring having a high spring rate which will cause the window to engage the wall with sufficient force to maintain the gasket on the inner face of the frame in dust tight engagement with the outer face of the wall about the opening when the window is closed, and to maintain the bearing surface on the outer edge of the frame securely against the outer face of the wall the window is open.

The rod preferably includes a first portion which extends through the wall and a second portion which extends laterally of the first portion, and the inner face of the window frame has

a pair of slots each receiving the second portion of one of the rods. A pair of axially aligned pins pivotally connect the second portions of the rods to the frame within the slots, and the first portion of each rod lies adjacent the inner face of the frame in the open position of the window to prevent movement of the window beyond its open position. The second portion of the rod has a groove through which the pin, which is carried by the frame, may be moved when the window is in its open position and the rod is pulled down to move the bearing surface of the frame away from the outer face of the wall against the force of the spring means, thereby permitting release of the window from the wall.

The pivotal axis of the pins is spaced from the bearing surface on the outer edge of the one side of the frame a greater distance than it is spaced from the inner face of the gasket, whereby the force of the spring is even greater. Also, each rod has a hole in it which moves from a position inwardly of the outer face of the wall to a position outwardly thereof as the rod is pulled down. Thus, a pin may be passed through this hole for bearing on the outer face of the wall and thereby holding the window in open position with even more force as the window is removed or installed.

In the drawings, wherein like reference characters are used throughout to designate like parts:

FIG. 1 is a perspective view of a ceiling mounted light fixture having a window connected to the lower wall thereof in accordance with the present invention;

FIG. 2 is an enlarged cross-sectional view of the fixture, with the window closed, and as seen along broken line 2—2 of FIG. 1;

FIG. 3 is a partial cross-sectional view of the frame, with the window closed, and as seen along broken line 3—3 of FIG. 2;

FIG. 4 is a view similar to FIG. 3, but during swinging of the window from the closed to open position;

FIG. 5 is another view similar to FIG. 3, but with the window in open position; and

FIG. 6 is a view similar to FIG. 5, but with the rod lowered to permit release of the window therefrom.

With reference now to the details of the above described drawings, the light fixture shown in FIG. 1, and indicated in its entirety by reference character 10, comprises a housing 11 adapted to be received within a ceiling recess for containing the usual internal components of the light fixture, such as a socket, a lamp for the socket, and electrical wiring connecting it to a suitable power source (not shown). A wall 12 disposed across the lower end of the housing 11 has an opening 13 through it which permits access to the interior of the fixture housing 11 for relamping or other operations from beneath the ceiling. The wall 12 includes a support plate 14 in which opening 13 is formed, a flange 15 about the outer edge of the support plate for attachment to the sidewalls of the housing, and a trim plate 16 about the flange for normally concealing the sidewalls of the housing 11 as well as the ceiling recess in which the housing is received in the case of a recessed fixture.

The support plate 14 is thus disposed inwardly of the trim plate 16 to form a recess in which a window 17 is received for closing the access opening 13 in dusttight fashion. Thus, as will be apparent from FIGS. 1, 2 and 3, the outer face of the window is substantially flush with the trim plate of the wall to provide a relatively smooth exterior appearance. As will also be apparent from the drawings, and for reasons which will be obvious from the description to follow, the sides of the window are spaced from the flange 15, when the window is in closed position, and the outer face of the window is spaced from the adjacent side of the flange and to one side of the opening 13 in the wall 12, when the window is open (FIG. 5).

The window 17 includes an open frame 18 having four sides 18A, 18B, 18C and 18D, and a light diffuser 19 carried by the frame for disposal symmetrically over the access opening 13 when the window is closed. A recess 20 is formed in the inner edges of the sides of the frame to receive a seal strip 21 about the outer edges of the diffuser 19, and a gasket 22 on the seal strip adjacent the inner face of the window frame engages the

outer face of the support plate 14 in the closed position of the window.

The window frame is connected to the wall 12 at its opposite sides 18B and 18D near its side 18A for swinging between its opened and closed positions. When the window is closed, it may be releasably secured to the wall 12 near the side 18C of the frame by means of screws 23 (see FIG. 1) or other suitable fasteners carried by sides 18B and 18D.

The novel arrangement for connecting the window frame to the wall 12 includes a pair of rods 24 which extend loosely through holes 25 in support plate 14 to permit some freedom of movement laterally of the holes, as will be described to follow. Each rod is urged upwardly by means of a coil spring 26 which is compressed between a cap 27 releasably secured about the upper end of the rod and a cap 28 surrounding the rod and supported on the inner face of the wall 12. Each rod 24 includes a vertical portion 24A which extends downwardly through the hole 25, and a horizontally extending portion 24B at the lower end of the vertical portion, and the portions 24B are received within slots 33 in the inner face of the sides 18B and 18D outwardly of gasket 22 and are pivotally connected to the sides by means of pins 34 extending across the slots and passing through the lower ends of the rods.

Each rod 24 has an enlarged head 31 above a neck 30 for normally bearing on the top of the cap 27 when the neck is received through a hole 29 in the cap and the head is turned to the position of FIG. 3. However, the hole 29 is enlarged at 29a (see FIG. 2) to pass the head 31 when the cap is turned 90°. Thus, as will be obvious from a comparison of FIGS. 2 and 3, the cap 27 may be forced downwardly against the force of spring 26 and then rotated 90° to align its enlarged head 31 with the enlargement 29a to permit the cap to be removed by allowing the enlargement 29a to move upwardly over the head 31. The cap 28 merely has a hole 32 through which the rod 24 extends for free movement vertically therein.

As will be appreciated from the foregoing, when the window is in the closed position shown in FIGS. 1, 2 and 3, the spring-compressed rods 24 and the releasable fasteners 23 maintain the gasket 22 tightly engaged against the support plate 14 in surrounding relation to the access opening 13. Upon release of the fasteners 23, the window may be swung downwardly to open position in which the outer edge of frame side 18B bears upon the support plate with the frame extending generally vertically to one side of the access opening 13. More particularly, and as illustrated in FIG. 4, the corner of the outer edge of side 18A will slide over the support plate as the opposite side 18C is swung downwardly toward a position beneath the side 18A.

During this time, and as will be apparent from FIG. 4, the springs 26 are first compressed from their expanded positions, when the window is closed, and then expanded to the positions they occupy when the window is open. As will also be apparent from the drawings, the pivotal axis of the aligned pins 34 is spaced from the bearing surface on the outer edge of frame side 18A a greater distance than it is from the inner face of gasket 22, so that the springs 26 will be more fully compressed when the frame has been moved to its fully open position (FIG. 5), and thus hold the window open with ever greater force.

As will also be apparent from FIG. 5, the axis of the pins 34 are so spaced from the inner face of the frame 18 that the edge of the vertical portion 24A of each rod will be substantially adjacent the inner face of the frame in the open position of the window shown in FIG. 5. This, of course, also serves to stabilize the window in its open position since it will prevent any retrograde movement of the window—i.e., movement to the left beyond the vertical position shown in FIG. 5.

The pins 34 are received within grooves 35 in the horizontally extending portions 24B of the rods 24, and normally held in the ends thereof by the force of springs 26. As will be apparent from FIG. 6, the slots 33 in which the lower ends of the rods are received are of such length that, with the window in the open position, the rods 24 may be pulled downwardly so as to move the upper ends of the grooves 35 therein below the

pins 34, as shown in FIG. 6, and thus permit the window to be released from the rods by movement laterally of the rods.

During removal or installation of the window, the rods 24 may be maintained in the position of FIG. 6 by means of pins 36 engaging with the outer or lower face of support plate 14. Thus, the holes in the rods for receiving these pins are, in the closed position of the window, normally disposed above the outer or lower face of the wall portion 14 a distance which causes them to move into the FIG. 6 position as the window is opened.

As will be apparent from FIG. 4, the spacing between the outer edges of the frame sides and the flange 15 facilitates swinging of the window between opened and closed positions without the necessity of first moving the window downwardly beneath the recess formed by the wall portions. It will also be apparent from FIG. 4 that the enlarged holes 25 through which the rods extend loosely permit the rods to move slightly out of the vertical as they are lowered and raised and the corner of one edge of the window frame moves across the outer face of the wall upon swinging of the window.

From the foregoing it will seen that this invention is one well adapted to attain all of the ends and objects hereinabove set forth, together with other advantages which are obvious and which are inherent to the apparatus.

It will be understood that certain features and subcombinations are of utility and may be employed without reference to other features and subcombinations. This is contemplated by and is within the scope of the claims.

As many possible embodiments may be made of the invention without departing from the scope thereof, it is to be understood that all matter herein set forth or shown in the accompanying drawings is to be interpreted as illustrative and not in a limiting sense.

The invention having been described, what is claimed is:

1. A closure, comprising a wall with an access opening therethrough, a panel, and means connecting the panel to the wall for swinging between a closed position in which it is over the opening and an open position to one side of said opening, said panel having a gasket on its inner face for engaging the outer face of the wall about said opening, in its closed position, and a surface on the outer edge of one side thereof for bearing on said outer face of the wall, in its open position, said connecting means including a pair of rods extending through the wall, means pivotally connecting the ends of said rods to the inner face of the panel near said one side thereof, and spring means engaging each said rod on the inner face of the panel to urge the inner face of the panel toward and into engagement with the outer face of said wall, in the closed position of the panel, and the bearing surface on the outer edge of said one side of the panel toward and into engagement with the outer face of said wall, in the open position of the panel, and means for releasably attaching the panel to the wall near the opposite side thereof.

2. A closure of the character defined in claim 1, wherein each said spring means engages at one end with said rod and at the other end with the inner face of the wall.

3. A closure of the character defined in claim 2, wherein each spring means is a coil spring.

4. A closure of the character defined in claim 1, wherein each said spring means is a coil spring.

5. A closure of the character defined in claim 1, wherein the ends of the rods are connected to the inner face of the panel outwardly of said gasket.

6. A closure of the character defined in claim 1, including means for releasing the means pivotally connecting the ends of said rods to the panel.

7. A closure of the character defined in claim 1, wherein each rod includes a first portion extending through said wall and a second portion extending laterally of the first portion, the inner face of said panel has a pair of slots each receiving the second portion of one of said rods, and said pivotally connecting means includes a pair of axially aligned pins each pivotally connecting the second portion of one rod to the panel within one of said slots.

5

6

8. A closure of the character defined in claim 7, wherein said first portion of each rod lies adjacent the inner face of the panel in the open position of the panel.

9. A closure of the character defined in claim 7, wherein the slots are formed in sides of the panel on opposite ends of said one side. 5

10. A closure of the character defined in claim 7, wherein each pin is carried by the panel, and the second portion of each rod has a groove through which the pin may be moved when the panel is in open position and the second portion of 10 the rod is moved away from the outer face of said wall against

the force of the spring means.

11. Apparatus of the character defined in claim 1, wherein the axis about which the rods pivot is spaced farther from the bearing surface of the outer edge of said one side of the panel than from the inner face of the panel, and each rod has a hole therein which moves from a position inwardly of the outer face of the wall to a position outwardly thereof, as the panel is moved from closed to open position, so as to receive a pin therethrough for bearing on the outer face of said wall.

* * * * *

15

20

25

30

35

40

45

50

55

60

65

70

75

UNITED STATES PATENT OFFICE
CERTIFICATE OF CORRECTION

Patent No. 3,644,729

Dated February 22, 1972

Inventor(s) Ralph M. McFarlin

It is certified that error appears in the above-identified patent and that said Letters Patent are hereby corrected as shown below:

In the claims, column 4, line 47, change "panel" (first occurrence) to --wall--.

Signed and sealed this 29th day of May 1973.

(SEAL)
Attest:

EDWARD M. FLETCHER, JR.
Attesting Officer

ROBERT GOTTSCHALK
Commissioner of Patents