



HU000031938T2

(19) **HU**(11) Lajstromszám: **E 031 938**(13) **T2****MAGYARORSZÁG**
Szellemi Tulajdon Nemzeti Hivatala**EURÓPAI SZABADALOM**
SZÖVEGÉNEK FORDÍTÁSA(21) Magyar ügyszám: **E 13 742414**(51) Int. Cl.: **B65D 85/804** (2006.01)(22) A bejelentés napja: **2013. 07. 19.**

(86) A nemzetközi (PCT) bejelentési szám:

PCT/EP 13/065270

(96) Az európai bejelentés bejelentési száma:

EP 20130742414

(87) A nemzetközi közzétételi szám:

WO 14016208

(97) Az európai bejelentés közzétételi adatai:

EP 2877412 A1 **2014. 01. 30.**

(97) Az európai szabadalom megadásának meghirdetési adatai:

EP 2877412 B1 **2016. 11. 23.**

(30) Elsőbbségi adatok:

12177645 **2012. 07. 24.** **EP**

(73) Jogosult(ak):

Nestec S.A., 1800 Vevey (CH)

(72) Feltalálók(k):

TALON, Christian, CH-1134 Vufflens-le-château (CH)

(74) Képviselő:

**Danubia Szabadalmi és Jogi Iroda Kft.,
Budapest**

(54)

Kapszula élelmiszerkészítő gépben való használatra

Az európai szabadalom ellen, megadásának az Európai Szabadalmi Közlönyben való meghirdetésétől számított kilenc hónapon belül, felszólalást lehet benyújtani az Európai Szabadalmi Hivatalnál. (Európai Szabadalmi Egyezmény 99. cikk(1))

A fordítást a szabadalmat az 1995. évi XXXIII. törvény 84/H. §-a szerint nyújtotta be. A fordítás tartalmi helyességét a Szellemi Tulajdon Nemzeti Hivatala nem vizsgálta.

(19)



(11)

EP 2 877 412 B1

(12)

EUROPEAN PATENT SPECIFICATION

(45) Date of publication and mention of the grant of the patent:
23.11.2016 Bulletin 2016/47

(51) Int Cl.:
B65D 85/804 (2006.01)

(21) Application number: **13742414.9**

(86) International application number:
PCT/EP2013/065270

(22) Date of filing: **19.07.2013**

(87) International publication number:
WO 2014/016208 (30.01.2014 Gazette 2014/05)

(54) A CAPSULE FOR USE IN A FOOD PREPARATION MACHINE

KAPSEL ZUR VERWENDUNG IN EINER LEBENSMITTELHERSTELLUNGSMASCHINE

CAPSULE DESTINÉE À ÊTRE UTILISÉE DANS UNE MACHINE DE PRÉPARATION D'ALIMENT

(84) Designated Contracting States:
AL AT BE BG CH CY CZ DE DK EE ES FI FR GB GR HR HU IE IS IT LI LT LU LV MC MK MT NL NO PL PT RO RS SE SI SK SM TR

(72) Inventor: **TALON, Christian**
CH-1134 Vufflens-le-Château (CH)

(30) Priority: **24.07.2012 EP 12177645**

(56) References cited:
EP-A1- 1 710 173 EP-A1- 2 210 827
EP-A1- 2 444 339 DE-U1-202005 021 160
US-A1- 2009 032 454 US-A1- 2010 077 928
US-A1- 2010 307 930

(43) Date of publication of application:
03.06.2015 Bulletin 2015/23

(73) Proprietor: **Nestec S.A.**
1800 Vevey (CH)

EP 2 877 412 B1

Note: Within nine months of the publication of the mention of the grant of the European patent in the European Patent Bulletin, any person may give notice to the European Patent Office of opposition to that patent, in accordance with the Implementing Regulations. Notice of opposition shall not be deemed to have been filed until the opposition fee has been paid. (Art. 99(1) European Patent Convention).

Description

Field of the invention

[0001] The present invention concerns an ingredient capsule for use in a food preparation machine, typically a beverage preparation machine.

Background of the invention

[0002] Beverage preparation machines are well known in the food science and consumer goods area. Such machines allow a consumer to prepare at home a given type of beverage, for instance a coffee-based beverage, e.g. an espresso or a brew-like coffee cup.

[0003] Today, most beverage preparation machines for in-home beverage preparation comprise a system made of a machine which can accommodate portioned ingredients for the preparation of the beverage. Such portions can be soft pods or pads, or sachets, but more and more systems use semi-rigid or rigid portions such as rigid pods or capsules. In the following, it will be considered that the beverage machine of the invention is a beverage preparation machine working with a rigid or semi-rigid capsule.

[0004] The machine comprises a receptacle or cavity for accommodating said capsule and a fluid injection system for injecting a fluid, preferably water, under pressure into the capsule. Water injected under pressure in the capsule, for the preparation of a coffee beverage according to the present invention, is preferably hot, that is to say at a temperature above 70°C. However, in some particular instances, it might also be at ambient temperature, or even chilled. The pressure inside the capsule chamber during extraction and/or dissolution of the capsule contents is typically about 1 to about 8 bar for dissolution products and about 2 to about 12 bar for extraction of roast and ground coffee. Such a preparation process differs a lot from the so-called "brewing" process of beverage preparation - particularly for tea and coffee, in that brewing involves a long time of infusion of the ingredient by a fluid (e.g. hot water), whereas the beverage preparation process allows a consumer to prepare a beverage, for instance coffee, within a few seconds.

[0005] The principle of extracting and/or dissolving the contents of a closed capsule under pressure is known, and consists typically of inserting the capsule in a receptacle or cavity of a machine, injecting a quantity of pressurized water into the capsule, generally after piercing a face of the capsule with a piercing injection element such as a fluid injection needle mounted on the machine, so as to create a pressurized environment inside the capsule either to extract the substance or dissolve it, and then release the extracted substance or the dissolved substance through the capsule. Capsules allowing the application of this principle have already been described for example in applicant's European patents n° EP 1472156 B1, and EP 1784344 B1.

[0006] Machines allowing the application of this principle have already been described for example in patents CH 605 293 and EP 242 556. According to these documents, the machine comprises a receptacle or cavity for the capsule and a perforation and injection element made in the form of a hollow needle comprising in its distal region one or more liquid injection orifices. The needle has a dual function in that it opens the top portion of the capsule on the one hand, and that it forms the water inlet channel into the capsule on the other hand.

[0007] The machine further comprises a fluid tank - in most cases this fluid is water - for storing the fluid that is used to dissolve and/or infuse and/or extract under pressure the ingredient(s) contained in the capsule. The machine comprises a heating element such as a boiler or a heat exchanger, which is able to warm up the water used therein to working temperatures (classically temperatures up to 80-90°C). Finally, the machine comprises a pump element for circulating the water from the tank to the capsule, optionally through the heating element. The way the water circulates within the machine is e.g. selected via a selecting valve means, such as for instance a peristaltic valve of the type described in applicant's European patent application EP 2162653 A1.

[0008] When the beverage to be prepared is coffee, one interesting way to prepare the coffee is to provide the consumer with a capsule containing roast and ground coffee powder, which is to be extracted with hot water injected therein.

[0009] In many instances, the machine comprises a capsule holder for holding a capsule, which is intended to be inserted in and removed from a corresponding cavity or receptacle of the machine. When a capsule holder is loaded with a capsule and inserted within the machine in a functional manner, the water injection means of the machine can fluidly connect to the capsule to inject water therein for a food preparation, as described above. A capsule holder was described for example in applicant's European patent EP 1967100 B1.

[0010] Capsules have been developed for such an application of food preparation, and in particular for beverage preparation, which are described and claimed in applicant's European patent EP 1784344 B1, or in European patent application EP 2062831.

[0011] In short, such capsules comprise typically:

- a hollow body and an injection wall which is impermeable to liquids and to air and which is attached to the body and adapted to be punctured by e.g. an injection needle of the machine,
- a chamber containing a bed of roast and ground coffee to be extracted, or a soluble ingredient or mix of soluble ingredients,
- an aluminium membrane disposed at the bottom end of the capsule, closing the capsule, for retaining the internal pressure in the chamber.

[0012] The aluminium membrane is designed for being

pierced with piercing means that are either integral with the capsule, or located outside of said capsule, for example within a capsule holder of the machine.

[0013] In the field of the present invention, it is considered that the piercing means is located outside of the capsule, for instance the piercing means is integrated to a capsule holder.

[0014] Usually, the piercing means is a plate having a substantially disc-shaped surface covered with piercing elements such as small pyramids or spikes, adapted in shape and size to pierce through the bottom membrane of the capsule when the latter is bent due to internal fluid pressure building-up within the capsule. Beyond the piercing effect, the piercing means also has a function of support of the bottom membrane, and ensures that the latter does not bend too much when subject to internal pressure within the capsule. It therefore prevents that the bottom membrane is completely torn open by the pressure. This would be particularly undesirable, since a wide opening through the membrane could allow ingredient material (e.g. roast and ground coffee) to pass through, and fall into the consumer cup, which would result in beverage contamination giving very poor in-cup product quality. The opening of the bottom membrane by the piercing means is therefore the result of a balanced mechanical effect, providing small openings through the membrane, which are due to action of the piercing elements, while the same piercing means prevents wide opening, bursting, or similarly wide tearing of the same bottom membrane.

[0015] As described and illustrated in the prior art publications, for instance in EP 1472156 B1, or in EP 2444339 A1 the surface of the piercing means - which in the cited prior art is a piercing plate - substantially corresponds to the surface of the capsule pierceable bottom membrane.

[0016] In some instances though, particularly when the beverage machine is made compatible with several capsule types, the piercing means can be designed such that its surface does not correspond to the entire surface of the bottom membrane. For example, the centre of the piercing means can be made hollow, and the piercing elements are distributed across a ring-shaped area rather than a disc-shaped area.

[0017] In such instances when the surface of the piercing means does not correspond to the surface of the capsule pierceable bottom membrane, the latter can burst or be torn before the appropriate pressure is reached within the capsule.

[0018] Capsule bursting can be such that a too wide opening is created through the bottom membrane of said capsule, through which some non-consumable ingredient e.g. coffee particles, can escape and flow into the cup, which is of course highly undesirable, as it results in a messy product dispensing, and poor quality of the resulting product in cup (e.g. mix of liquid coffee with solid coffee particles). This is especially the case if the piercing means of the machine comprise a zone which is hollow,

i.e. does not comprise.

[0019] Moreover, product to be prepared inside the capsule requires an appropriate pressure and temperature, in order to achieve the best texture and taste. If the bottom membrane of the capsule opens too rapidly, the adequate internal pressure within the capsule is not reached and the resulting product does not have appropriate sensory quality.

[0020] Capsules are described in a certain number of prior art publications, in particular in EP1710173, US2010077928, EP2210827, US2010307930 and in US2009032454, which comprise rigid structure in association with frangible or otherwise permeable thin walls, however, none of the capsules described in these documents requires or teaches a solution to prevent that an impermeable flexible thin wall of the capsule ruptures or is otherwise damages accidentally due to a high pressure differential between the two sides of said wall.

[0021] It is therefore a main objective of the invention to provide an ingredient capsule for use in a food, e.g. a beverage, preparation machine, that prevents inadequate (typically too early and/or too wide) capsule opening, and therefore to provide the best in-cup quality to the consumer, in particular when the piercing means of the machine is not specifically adapted to opening such a capsule.

Summary of the invention

[0022] The main objective set out above is met with a capsule for containing a food ingredient, adapted for use in a food preparation machine able to inject a fluid under pressure inside said capsule to prepare a food product, said capsule comprising a capsule body with side walls, a top wall, and an impermeable flexible pierceable bottom membrane, characterized in that it further comprises a rigid support structure located adjacent and outside of said flexible pierceable bottom membrane, such that said structure covers and supports partially said membrane.

[0023] The supporting effect achieved by the supporting structure is against a vertical deformation of the pierceable bottom membrane, in some area where deformation, and piercing of said membrane is not required. This is for instance the case in the centre of said bottom membrane. Since the latter is deformable, when pressure builds up within the capsule compartment, the pressure acts vertically against the bottom membrane, which tends to bend downwards. Bursting or tearing of said membrane occurs too rapidly, preferentially in the centre, in absence of the supporting structure according to the invention.

[0024] In a highly preferred embodiment of the invention, the support structure comprises:

- (i) at least one support area having a thickness and a rigidity sufficient to withstand internal pressure within said capsule, up to 12 bar, preferably up to 15 bar, more preferably up to 20 bar, and

(ii) at least one open-worked, punched, or otherwise open area that does not support the bottom membrane of the capsule.

[0025] At least one support area of the support structure is located so as to support the centre of the bottom membrane.

[0026] Also advantageously, the support structure can be integrally formed with the capsule side walls, for instance by injection moulding the capsule side walls with the support structure at the bottom. In such a case, the pierceable bottom membrane of the capsule can be welded at the inside bottom portion of the capsule side walls thereafter.

[0027] In a preferred embodiment of the invention, the flexible bottom membrane is pierceable when the pressure inside the capsule is comprised between 0.1 and 20 bar, preferably between 1 and 15 bar, more preferably between 2 and 12 bar.

[0028] Advantageously, the bottom membrane can be made of aluminium and has a thickness comprised between 10 μm and 100 μm , preferably 20 μm and 50 μm .

[0029] Also advantageously, the thickness of the side walls can be between 50 μm and 1000 μm , preferably between 100 μm and 500 μm .

[0030] In any case, the ingredient is preferably a beverage ingredient, such as roast and ground coffee, leaf tea, a soluble powdered coffee, tea, chocolate, fruit and/or vegetable juice, soup, milk or creamer, infant nutrition product, or a combination thereof.

Brief description of the drawing

[0031] Additional features and advantages of the present invention are described in, and will be apparent from, the description of the presently preferred embodiments which are set out below with reference to the drawings in which:

Figure 1 is a schematic, partially cut, perspective view of a first embodiment of a capsule according to the present invention;

Figure 2 is a schematic, partially cut, perspective view of a second embodiment of a capsule according to the present invention.

Detailed description of the invention

[0032] The capsule 1 illustrated in **figure 1** is adapted for containing a beverage ingredient, such as roast and ground coffee. It comprises a thermoformed rigid or semi-rigid capsule body with side walls 2, a top pierceable membrane 3 that is sealed onto the upper edges of the side walls, and a bottom pierceable flexible membrane 4 that is sealed onto the internal surface of the side walls, at their lower part.

[0033] According to the invention, the capsule comprises a support structure 5 which is integrally made with

the side walls 2 when said capsule is thermoformed from a single plastic sheet. The capsule further comprises punched out windows 6 that define dispensing holes. Through the bottom windows, the bottom membrane 4 is visible, and accessible from the outside, since said membrane is adjacent to the support structure 5, as shown in **figure 1**.

[0034] When the capsule is functionally inserted into the receptacle of a beverage preparation machine, and said machine injects a fluid under pressure through the top membrane 3, into the capsule, fluid pressure builds up within the capsule. As fluid pressure increases, the bottom membrane is able to deflect and bend downwards, until it contacts piercing elements such as small sharp pyramids of piercing means - for instance a piercing plate - disposed there below. The piercing plate is part of the machine, for instance it can be integrated to the capsule holder of said machine. When the membrane bends and presses sufficiently onto the piercing elements, it is pierced and the beverage prepared within the capsule by mixing the beverage ingredient and the fluid under pressure, can escape and flow into a cup placed below. The surface of the rounded windows is sufficient to ensure that the bottom membrane 4 does not flex too much so that it is not torn open, in particular in its centre portion.

[0035] Alternatively, to a thermoformed and punched out manufacturing process, the capsule according to the invention, and as illustrated in **figure 1**, can be injected in one piece. Or as another possible alternative, the capsule can be injected in two pieces, one for the capsule side walls 2 and another for the support structure 5, both parts being then assembled to complete the capsule body.

[0036] All constitutive parts of the capsule, including the top 3 and bottom 4 membranes, are impermeable, and preferably they are made of a gas-tight material. It is important that none of the capsule walls be permeable to liquids, in order to ensure that a proper fluid pressure can build up inside the capsule during the preparation of the food or beverage product. Fluid leakage through a wall of the capsule could lead to a poor internal pressure build-up which would impact negatively on the product quality, and in some cases, it could even prevent the bottom membrane 4 from bending sufficiently towards the machine piercing means, resulting in a capsule not opening at all, which is of course highly undesirable.

[0037] An alternative embodiment of the invention is illustrated in **figure 2**. The capsule 1 shown therein is very similar to that of **figure 1** described above. However, in that case, the capsule side walls 2 do not extend to the bottom side of the capsule body, such that the bottom pierceable membrane 4 is largely accessible from below said capsule. The support structure comprises a main central portion 5 that is linked to the lower edge of the capsule side walls 2 by at least two, preferably three, more preferably four linking arms 7.

[0038] When the capsule is functionally inserted inside

the corresponding capsule receptacle of a food (e.g. beverage) preparation machine, and when a fluid is injected under pressure within said capsule through the top membrane 3, fluid pressure within the capsule increases as said fluid is mixed with a food ingredient contained therein. As capsule pressure builds up, the bottom membrane 4 flexes downward and contacts the piercing elements (e.g. sharp pyramid-like protrusions) of the machine piercing means (not illustrated in the drawing). When fluid pressure inside the capsule is sufficient, the portions of the bottom membrane 4 in contact with the piercing elements is sufficient to pierce through said membrane and allow the product prepared within said capsule to be released. In spite of the relatively high opening pressure, which can be up to 15 bar, but is preferably within the range of 2 to 12 bar, the whole membrane cannot flex downward such that a mechanical forces exerted on said membrane are insufficient to tear the latter completely.

[0039] With a capsule according to the invention, a proper balance is achieved between:

- the support effect of the support structure 5, which ensures that the whole membrane does not flex and therefore prevents complete tearing, and
- the possibility of some parts of said bottom membrane to flex down onto the piercing means such that they can be pierced with small dispensing holes having a diameter sufficiently small to let a liquid through but not solid particles, e.g. pierced holes having a diameter within the range of 10 to 1000 μ m, preferably between 50 and 700 μ m.

[0040] In order to achieve such a proper balanced deformation effect of the bottom membrane, the surface of the support structure 5 is preferably such that the surface of the bottom membrane 4 which is not supported, i.e. which is free to flex under internal capsule pressure, corresponds to the surface of the piercing means being covered with piercing elements. As explained above, said piercing elements do not only play the role of opening structures, but at the same time, they limit the deformation of the bottom membrane, such that the latter is pierced without tearing.

[0041] Lastly, the support of the bottom membrane can be manufactured by coating said bottom membrane with a glue or other suitable polymeric material that solidifies, which provides a solid, un-deformable coated support.

[0042] It should be understood that various changes and modifications to the presently preferred embodiments described herein will be apparent to those skilled in the art. Such changes and modifications can be made without departing from the

[0043] scope of the present invention and without diminishing its attendant advantages. It is therefore intended that such changes and modifications be covered by the appended claims.

Claims

1. A capsule (1) for containing a food ingredient, adapted for use in a food preparation machine able to inject a fluid under pressure inside said capsule to prepare a food product, said capsule comprising a capsule body with side walls (2), a top wall (3), and an impermeable flexible pierceable bottom membrane (4), **characterized in that** it further comprises a rigid support structure (5, 7) located adjacent and outside of said flexible pierceable bottom membrane, such that said structure covers and supports partially said membrane (4), wherein at least one support area of the support structure (5, 7) is located so as to support the centre of the bottom membrane (4) of said capsule (1).
2. A capsule (1) according to claim 1, wherein said support structure (5, 7) comprises:
 - (i) at least one support area (5) having a thickness and a rigidity sufficient to withstand internal pressure within said capsule, up to 12 bar, preferably up to 15 bar, more preferably up to 20 bar, and
 - (ii) at least one open-worked, punched, or otherwise open area (6) that does not support the bottom membrane (4) of the capsule (1).
3. A capsule (1) according to any of the preceding claims, wherein said support structure is integrally formed with the capsule side walls.
4. A capsule (1) according to any of the preceding claims, wherein the flexible bottom membrane (4) is pierceable when the pressure inside the capsule is comprised between 0. and 20 bar, preferably between 1 and 15 bar, more preferably between 2 and 12 bar.
5. A capsule (1) according to claim 4, wherein said bottom membrane (4) is made of aluminium and has a thickness comprised between 10 μ m and 100 μ m, preferably 20 μ m and 50 μ m.
6. A capsule (1) according to any of the preceding claims, wherein the thickness of the side walls (2) is between 50 μ m and 1000 μ m, preferably between 100 μ m and 500 μ m.
7. A capsule (1) according to any of the preceding claims, wherein the ingredient is a beverage ingredient, such as roast and ground coffee, leaf tea, a soluble powdered coffee, tea, chocolate, fruit and/or vegetable juice, soup, milk or creamer, infant nutrition product, or a combination thereof.

Patentansprüche

1. Kapsel (1) zur Aufnahme eines Lebensmittel-Inhaltsstoffs, angepasst für die Verwendung in einer Lebensmittelherstellungsmaschine, die dazu ausgelegt ist, ein Fluid unter Druck in die Kapsel zu injizieren, um ein Lebensmittelprodukt herzustellen, wobei die Kapsel umfasst: einen Kapselkörper mit Seitenwänden (2), eine obere Wand (3) und eine undurchlässige, flexible, durchstechbare Bodenmembran (4), **dadurch gekennzeichnet, dass** sie weiterhin eine starre Trägerstruktur (5, 7) umfasst, die sich angrenzend an die und außerhalb der flexiblen, durchstechbaren Bodenmembran befindet, sodass die Struktur die Membran (4) teilweise bedeckt und trägt, wobei mindestens ein Trägerbereich der Trägerstruktur (5, 7) so angeordnet ist, dass er die Mitte der Bodenmembran (4) der Kapsel (1) trägt.
2. Kapsel (1) nach Anspruch 1, wobei die Trägerstruktur (5, 7) umfasst:
 - (i) mindestens einen Trägerbereich (5) von hinreichender Dicke und Starrheit, um dem Innendruck in der Kapsel standzuhalten: bis zu 1,2 MPa (12 bar), vorzugsweise bis zu 1,5 MPa (15 bar), mehr bevorzugt bis zu 2 MPa (20 bar), und
 - (ii) mindestens einen durchbrochenen, gelochten oder anderweitig offenen Bereich (6), der die Bodenmembran (4) der Kapsel (1) nicht trägt.
3. Kapsel (1) nach einem der vorstehenden Ansprüche, wobei die Trägerstruktur einstückig mit den Seitenwänden der Kapsel ausgebildet ist.
4. Kapsel (1) nach einem der vorstehenden Ansprüche, wobei die flexible Bodenmembran (4) durchstechbar ist, wenn der Druck innerhalb der Kapsel im Bereich zwischen 0,01 und 2 MPa (zwischen 0,1 und 20 bar), vorzugsweise zwischen 0,1 und 1,5 MPa (zwischen 1 und 15 bar), mehr bevorzugt zwischen 0,2 und 1,2 MPa (zwischen 2 bis 12 bar) umfasst ist.
5. Kapsel (1) nach Anspruch 4, wobei die Bodenmembran (4) aus Aluminium gefertigt ist und eine Dicke aufweist, die zwischen 10 μm und 100 μm , vorzugsweise zwischen 20 μm und 50 μm umfasst ist.
6. Kapsel (1) nach einem der vorstehenden Ansprüche, wobei die Dicke der Seitenwände (2) zwischen 50 μm und 1000 μm , vorzugsweise zwischen 100 μm und 500 μm , liegt.
7. Kapsel (1) nach einem der vorstehenden Ansprüche, wobei der Inhaltsstoff ein Getränke-Inhaltsstoff ist, wie z. B. gerösteter und gemahlener Kaffee, Teeblätter, löslicher Pulverkaffee, Tee, Schokolade,

Frucht- und/oder Gemüsesaft, Suppe, Milch oder Kaffeeweißler, Säuglingsnahrungsprodukt, oder eine Kombination davon.

Revendications

1. Capsule (1) destinée à contenir un ingrédient alimentaire, adapté à l'utilisation dans une machine de préparation d'aliments apte à injecter un fluide sous pression à l'intérieur de ladite capsule pour préparer un produit alimentaire, ladite capsule comprenant un corps de capsule avec des parois latérales (2), une paroi supérieure (3) et une membrane de fond flexible imperméable (4) pouvant être percée, **caractérisée en ce qu'elle** comprend en outre une structure de support rigide (5, 7) adjacente et à l'extérieur de ladite membrane de fond flexible pouvant être percée, de sorte que ladite structure recouvre et supporte partiellement ladite membrane (4), dans laquelle au moins une zone de support de la structure de support (5, 7) est située de manière à supporter le centre de la membrane de fond (4) de ladite capsule (1).
2. Capsule (1) selon la revendication 1, dans laquelle ladite structure de support (5, 7) comprend :
 - (i) au moins une zone de support (5) ayant une épaisseur et une rigidité suffisantes pour résister à la pression interne à l'intérieur de ladite capsule, jusqu'à 1,2 MPa (12 bar), de préférence jusqu'à 1,5 MPa (15 bar), plus préférablement jusqu'à 2 MPa (20 bar), et
 - (ii) au moins une zone ajourée, poinçonnée ou autrement ouverte (6) qui ne supporte pas la membrane de fond (4) de la capsule (1).
3. Capsule (1) selon l'une quelconque des revendications précédentes, dans laquelle ladite structure de support est solidaire des parois latérales de la capsule.
4. Capsule (1) selon l'une quelconque des revendications précédentes, dans laquelle la membrane de fond flexible (4) peut être percée lorsque la pression à l'intérieur de la capsule est comprise entre 0,01 et 2 MPa (entre 0,1 et 20 bar), de préférence entre 0,1 et 1,5 MPa (entre 1 et 15 bar), plus préférablement entre 0,2 et 1,2 MPa (entre 2 et 12 bar).
5. Capsule (1) selon la revendication 4, dans laquelle ladite membrane de fond (4) est constituée d'aluminium et a une épaisseur comprise entre 10 μm et 100 μm , de préférence 20 μm et 50 μm .
6. Capsule (1) selon l'une quelconque des revendications précédentes, dans laquelle l'épaisseur des pa-

rois latérales (2) est entre 50 μm et 1000 μm , de préférence entre 100 μm et 500 μm .

7. Capsule (1) selon l'une quelconque des revendications précédentes, dans laquelle l'ingrédient est un ingrédient de boisson, tel que du café torréfié et moulu, du thé en feuilles, un café en poudre soluble, du thé, du chocolat, du jus de fruits et/ou de légumes, de la soupe, du lait ou de la crème à café, un produit d'alimentation pour bébé ou une combinaison de ces éléments.

5

10

15

20

25

30

35

40

45

50

55

7

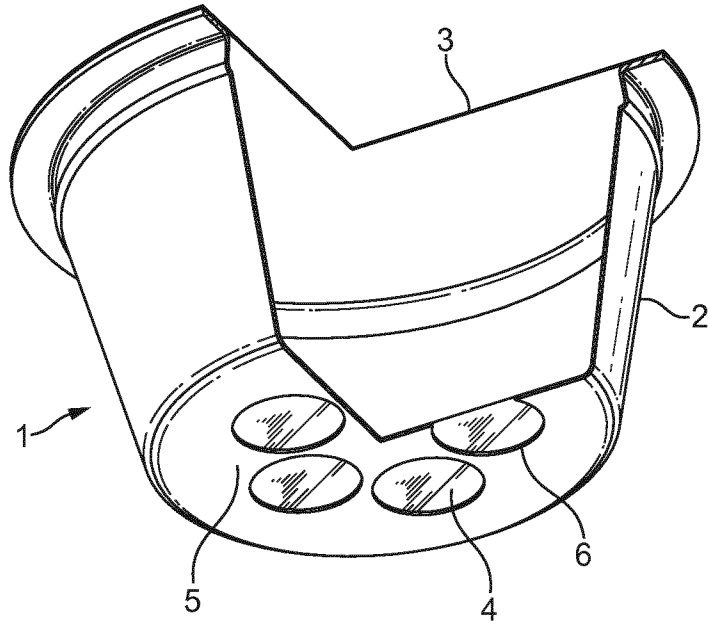

FIG. 1

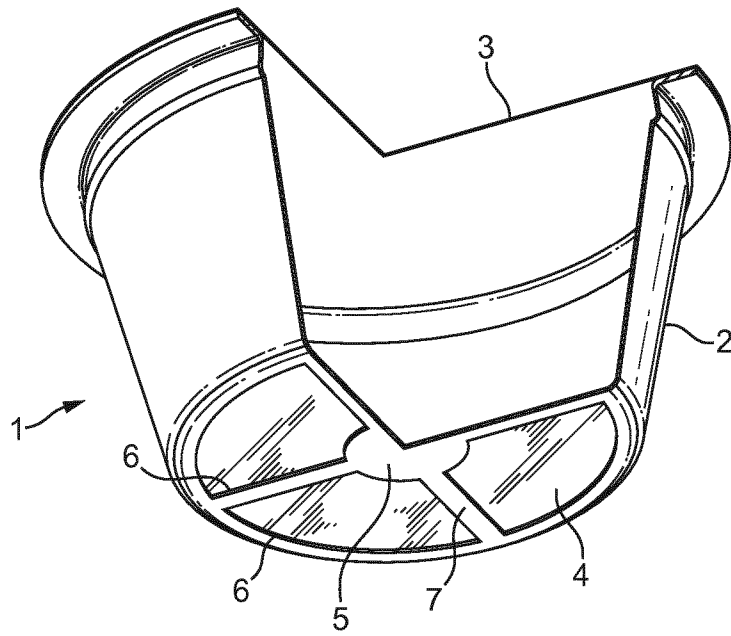

FIG. 2

REFERENCES CITED IN THE DESCRIPTION

This list of references cited by the applicant is for the reader's convenience only. It does not form part of the European patent document. Even though great care has been taken in compiling the references, errors or omissions cannot be excluded and the EPO disclaims all liability in this regard.

Patent documents cited in the description

- EP 1472156 B1 [0005] [0015]
- EP 1784344 B1 [0005] [0010]
- CH 605293 [0006]
- EP 242556 A [0006]
- EP 2162653 A1 [0007]
- EP 1967100 B1 [0009]
- EP 2062831 A [0010]
- EP 2444339 A1 [0015]
- EP 1710173 A [0020]
- US 2010077928 A [0020]
- EP 2210827 A [0020]
- US 2010307930 A [0020]
- US 2009032454 A [0020]

KAPSZULA ÉLELMISZERKÉSZÍTŐ GÉPBE VALÓ HASZNÁLATRA

Szabadalmi igénypontok

1. Kapszula (1) élelmiszerösszetevő tárolására, amely élelmiszertermék készítéséhez a kapszulába nyomás alatt lévő fluidum injektálására alkalmas élelmiszerkészítő gépben való használatra alkalmasan van kiképezve, a kapszulának oldalfalakkal (2), felső fallal (3) és áthatolhatatlan, flexibilis, áttörhető alsó membránnal (4) rendelkező kapszulateste van, **azzal jellemezve**, hogy merev tartószerkezete (5, 7) van, amely a flexibilis áttörhető alsó membránnal szomszédosan és azon kívül olyan módon van elhelyezve, hogy fedí és részben tartja a membránt (4), ahol a tartószerkezet (5, 7) legalább egy tartótartománya a kapszula (1) alsó membránja (4) közepét tartón van elhelyezve.
2. Az 1. igénypont szerinti kapszula (1), ahol a tartószerkezet (5, 7) tartalmaz
 - (i) a kapszulában fellépő legfeljebb 12 bar, előnyösen legfeljebb 15 bar, ennél előnyösebben legfeljebb 20 bar belső nyomással szembeni ellenálláshoz elegendő vastagsággal és merevséggel rendelkező legalább egy tartótartományt (5), továbbá
 - (ii) a kapszula (1) alsó membránját (4) nem tartó legalább egy áttört, átlyukasztott vagy másként megnyitott tartományt (6).
3. Az előző igénypontok bármelyike szerinti kapszula (1), ahol a tartószerkezet a kapszula oldalfalaival egyetlen darabként van kiképezve.
4. Az előző igénypontok bármelyike szerinti kapszula (1), ahol a flexibilis alsó membrán (4) a kapszulában fellépő 0,1 bar és 20 bar közé, előnyösen 1 és 15 bar közé, ennél előnyösebben 2 és 12 bar közé eső nyomáson áttörhető.
5. A 4. igénypont szerinti kapszula (1), ahol az alsó membrán (4) alumíniumból van, továbbá vastagsága 10 µm és 100 µm között, előnyösen 20 µm és 50 µm között van.
6. Az előző igénypontok bármelyike szerinti kapszula (1), ahol az oldalfalak (2) vastagsága 50 µm és 1000 µm között, előnyösen 100 µm és 500 µm között van.
7. Az előző igénypontok bármelyike szerinti kapszula (1), ahol az összetevőt italösszetevő, például pörkölt és őrölt kávé, tealevél, oldható porított kávé, tea, csokoládé, gyümölcs- és/vagy zöldséglé, leves, tej vagy krémesítő, csecsemőtápszer vagy ezek kombinációja képezi.