

(19) World Intellectual Property Organization  
International Bureau



(43) International Publication Date  
12 June 2003 (12.06.2003)

PCT

(10) International Publication Number  
WO 03/049025 A1

- (51) International Patent Classification<sup>7</sup>: G06K 19/07, 19/04, B65H 75/18
- (72) Inventor: SCHWANDNER, Frank; Franz-Pauly-Str. 85, 52080 Aachen (DE).
- (21) International Application Number: PCT/US02/37900
- (74) Agent: THURNAU, Jeffrey; The Gates Corporation, Mail Stop: 31-4-1-A3, 900 S. Broadway, Denver, CO 80209 (US).
- (22) International Filing Date: 25 November 2002 (25.11.2002)
- (81) Designated States (national): AE, AG, AL, AM, AT, AU, AZ, BA, BB, BG, BR, BY, BZ, CA, CH, CN, CO, CR, CU, CZ, DE, DK, DM, DZ, EC, EE, ES, FI, GB, GD, GE, GH, GM, HR, HU, ID, IL, IN, IS, JP, KE, KG, KP, KR, KZ, LC, LK, LR, LS, LT, LU, LV, MA, MD, MG, MK, MN, MW, MX, MZ, NO, NZ, OM, PH, PL, PT, RO, RU, SD, SE, SG, SI, SK, SL, TJ, TM, TN, TR, TT, TZ, UA, UG, UZ, VN, YU, ZA, ZM, ZW.
- (25) Filing Language: English
- (26) Publication Language: English
- (30) Priority Data: 10/005.083 4 December 2001 (04.12.2001) US
- (84) Designated States (regional): European patent (AT, BE, BG, CH, CY, CZ, DE, DK, EE, ES, FI, FR, GB, GR, IE, IT, LU, MC, NL, PT, SE, SK, TR).
- (71) Applicant: THE GATES CORPORATION [US/US]; 900 South Broadway, Denver, CO 80209 (US).

[Continued on next page]

(54) Title: SPINDLE SLEEVE WITH TRANSPONDER

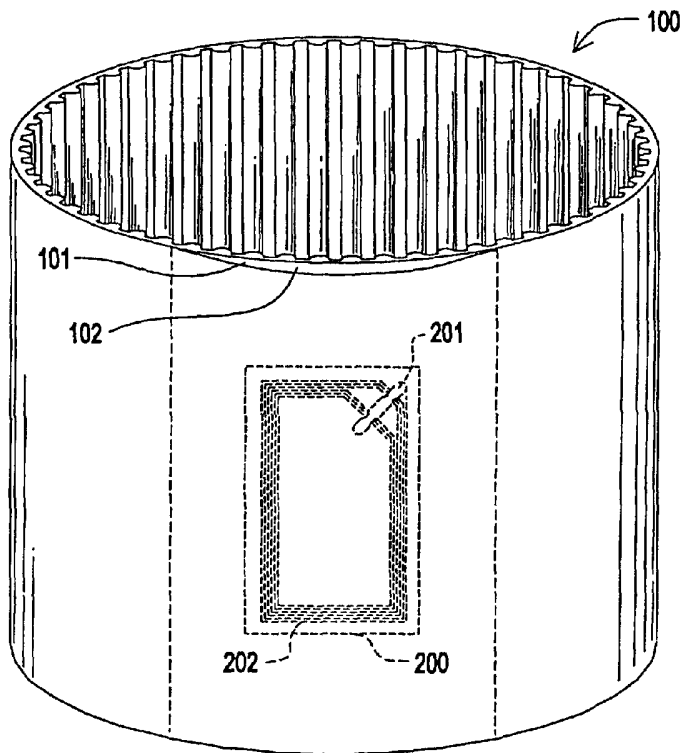

(57) Abstract: The invention comprises a transponder (200) moveably implanted into a pocket (101) on an elastomeric spindle sleeve (100). The pocket comprises a plastic lining which is formed in the sleeve during cure or vulcanization. The transponder is inserted into the pocket once cure or vulcanization of the sleeve is complete. The open ends of the pocket are then sealed closed with an adhesive. Since the transponder is not molded into or otherwise bonded to the pocket during fabrication the transponder may move within the pocket. This minimizes stresses that may otherwise be transmitted to the transponder during flexing of the sleeve, thereby extending a transponder life. The transponder collects, stores and transmits manufacturing data which can be read by hand-held or stationary electronic devices. The transponder comprises a microchip and antenna in addition to a plastic or paper laminate upon which it is mounted. The transponder is activated by RF energy received by the antenna and therefore needs no battery.



WO 03/049025 A1



**Published:**

- with international search report
- with amended claims

*For two-letter codes and other abbreviations, refer to the "Guidance Notes on Codes and Abbreviations" appearing at the beginning of each regular issue of the PCT Gazette.*

Docket Number O01-035PCT

Title

Spindle Sleeve with Transponder

5 Field of the Invention

The invention relates a spindle sleeve having a transponder, and more particularly, a spindle sleeve having a pocket to receive a transponder wherein the transponder is not bound to the pocket.

10 Background of the Invention

Various spun materials, including glass fibers, are manufactured by a spinning process. As the fibers are spun they are wound on a spindle. The spindle will generally  
15 comprise a cardboard cylinder.

It is necessary to the manufacturing process that certain information be marked on each spindle once the manufacturing process is complete. This allows identification and tracking of the glass fiber on each  
20 spindle.

Typically, the information is marked on each spindle optically for reading by a person, or with a bar code reader.

Other non-optical means of marking and reading  
25 information are available. For example, transponders may be molded into a product. The transponder stores and transmits information as required by a user. The transponders are generally queried by an interrogator when the stored information is needed.

30 Representative of the art is US 5,028,918 to Giles et al. (1991) which discloses a phase encoded transponder circuit which may be a passive device capable of response

to an interrogating signal and is capable of transmitting an individual unique identification code.

Also representative of the art is EP 956537A1 to PAV Card GmbH which discloses a transmission module for  
5 contactless transmission of data between a ship and a reading device.

Also representative of the art is WO99/23024 to Wibmer GmbH which discloses a spool sleeve having interconnected layers, an inner layer fitted with a notch in which a  
10 correspondingly formed transponder is embedded whose mass is at least approximately the same as that of the piece of strip that has been cut out so no imbalance between the sleeve and transponder arises.

However, the prior art transponders are molded into  
15 the product. As such, they are susceptible to mechanical damage caused by stresses transmitted to the transponder resulting from flexing of the product. Repeated flexing of the transponder during use results in premature failure.

What is needed is a spindle sleeve having means for  
20 electronically processing data. What is needed is a spindle sleeve having a transponder for receiving and transmitting data. What is needed is a spindle sleeve having a sealable pocket for receiving a transponder. What is needed is a spindle sleeve having means for non-fixedly  
25 receiving a transponder. What is needed is a spindle sleeve having a sealable pocket located radially outward from tensile cords to minimize transmitted stresses. The present invention meets these needs.

30

Summary of the Invention

The primary aspect of the invention is to provide a spindle sleeve having means for electronically processing data.

5        Another aspect of the invention is to provide a spindle sleeve having a transponder for receiving and transmitting data.

10        Another aspect of the invention is to provide a spindle sleeve having a sealable pocket for receiving a transponder.

      Another aspect of the invention is to provide a spindle sleeve having means for non-fixedly receiving a transponder.

15        Another aspect of the invention is to provide a spindle sleeve having a sealable pocket located radially outward from tensile cords to minimize transmitted stresses.

20        Other aspects of the invention will be pointed out or made obvious by the following description of the invention and the accompanying drawings.

25        The invention comprises a transponder moveably implanted into a pocket on an elastomeric spindle sleeve. The pocket comprises a plastic lining which is formed in the sleeve during cure or vulcanization. The transponder is inserted into the pocket once cure or vulcanization of the sleeve is complete. The open ends of the pocket are then sealed closed with an adhesive. Since the transponder is not molded into or otherwise bonded to the pocket during fabrication the transponder may move within the pocket.

30        This minimizes stresses that may otherwise be transmitted to the transponder during flexing of the sleeve, thereby extending a transponder life. The transponder collects,

stores and transmits manufacturing data which can be read by hand-held or stationary electronic devices. The transponder comprises a microchip and antenna in addition to a plastic or paper laminate upon which it is mounted.

5 The transponder is activated by RF energy received by the antenna and therefore needs no battery.

#### Brief Description of the Drawings

Fig. 1 is a perspective view of the transponder in the sleeve pocket.

0

Fig. 2 is a plan view of a transponder.

Fig. 3 is a perspective view of a spinning machine mandrel portion including an inventive sleeve.

Fig. 4 is a cross-sectional view of the inventive sleeve at 4-4 in Fig. 5.

15

Fig. 5 is a sleeve tooth profile.

The accompanying drawings, which are incorporated in and form a part of the specification, illustrate preferred embodiments of the present invention, and together with a description, serve to explain the principles of the invention.

20

#### Detailed Description of the Preferred Embodiment

Fig. 1 is a perspective view of the transponder in a sleeve pocket. The transponder 200 comprises a microprocessor 201 connected to a coil antenna 202. The transponder and antenna are sealed into a pocket 101 formed in elastomeric sleeve 100. The sleeve is then used, for example, on a spinning machine.

25

Sleeve 100 is fabricated in a manner known in the elastomeric belt fabricating art, namely, successive layers of elastomeric are built up on a build mandrel (not shown).

30

During fabrication, a single piece 102 of polyester plastic is placed between elastomeric layers. Piece 102 may also comprise a woven or non-woven material depending on the temperature during use. Tensile cords are also wound on the sleeve build, see Fig. 4. The sleeve is fabricated with tensile cords wound in a longitudinal direction in order to resist the centrifugal forces generated by the spinning process. The sleeve may experience rotational speeds of 5000 RPM or greater. The tensile cords may comprise polyester, fiberglass, nylon 6.6, nylon 4.6, aramid, cotton and equivalent materials known in the art. The built-up belt is then cured or vulcanized by application of heat and pressure. The vulcanized slab may then be cut into individual sleeves.

Piece 102 is laminated between successive layers of elastomeric to form a void comprising a receiving portion or pocket 101. Piece 102 prevents adjacent elastomeric layers from bonding together across the piece. Piece 102 is oriented radially outwardly of the tensile cords, between the tensile cords and an overcord elastomeric layer 105, see Fig. 4. This prevents the transponder from being crushed between a spinner mandrel and the tensile cords when the sleeve is installed on a spinning machine, see Fig. 3. Piece 102 may comprise any non-metallic material that will bond on only a single side to the elastomeric during cure or vulcanization. This assures a receiving pocket will be formed and maintained during vulcanization or cure without the layers of elastomeric bonding together. Further, piece 102 is non-metallic so as not to interfere with the RF signals received by or transmitted from the transponder antenna. Alternatively, piece 102 may be removed from the sleeve after curing or vulcanization in

order to give the proper finished sleeve thickness  $t$ , see Fig. 4, once the transponder is inserted. Various thicknesses of piece 102 may be used to achieve a proper finished sleeve thickness.

5        Alternatively, a portion of the elastomeric layer containing the pocket may be omitted during fabrication representing the thickness of the transponder plus piece 102 so that a proper uniform finished thickness about an entire circumference will be achieved when the transponder  
10 is inserted into the pocket.

Once the vulcanization or cure is complete, the belt built is cut into the appropriate widths, each width having a pocket 101. Transponder 200 is inserted into pocket 101. Once the transponder is inserted, the open ends of the  
15 pocket 111 are sealed shut using any suitable adhesive such as cyanacrylate or any equivalents thereof, see Fig. 4.

Although the ends of the pocket are sealed closed, the transponder is not sealed to the pocket. Instead, the transponder is free to move about within the sealed pocket,  
20 minimizing or eliminating stresses otherwise transmitted to the transponder by flexing of the sleeve during removal from a spinning machine, or during removal from a glass coil.

Fig. 2 is a plan view of a transponder. The  
25 transponder 200 is a passive device without an internal power supply. The transponder receives a radio frequency (RF) or clock signal from an interrogator. It accumulates voltage through the coil antenna 202 from the input signal. The transponder uses the accumulated voltage from the  
30 interrogating signal to power the processor 201, which reads the memory and transmits the appropriate response back to the interrogator.

Transponders of the type described above are known in the art. For example, and not by way of limitation, a suitable transponder is manufactured by PAV Card GmbH, Germany. The specific product is PAV model no. 16A-MIR.

5 The processor 201 and coil antenna 202 are laminated on a durable flexible plastic material 203. An overall thickness of the laminated transponder is less than 1mm. This form of transponder is extremely thin and wear resistant and is especially suitable to the application where sleeve overall  
10 thickness is limited to a maximum of approximately 3mm. This example is not offered by way of limitation as any equivalent transponder will perform as well. Material 203 is non-metallic so as not to interfere with RF signals.

Fig. 3 is a perspective view of a spinning machine  
15 portion including an inventive sleeve. In use, the rubber sleeve containing the transponder is mounted in a spinning machine, for spinning glass fibers for example. The spinning machine comprises a mandrel portion, shown in part in Fig. 3, upon which a coil is spun. The depiction of the  
20 mandrel portion M in Fig. 3 is an illustrative example and not offered as a limitation to a particular form or style of spinning machine. Mandrel projections M describe a generally cylindrical form. The mandrel portion is manipulated by a spinning machine in a manner known in the  
25 art. The inventive sleeve has a generally belt-like shape that is placed over the mandrel portion.

The material is then spun onto the sleeve during fabrication. Once the sleeve is loaded with a fiber coil, the mandrel portion M is collapsed inward and removed from  
30 an inner diameter of the sleeve. The coil remains on the flexible sleeve during handling and shipping. Once the coil is received by a user the transponder is read. The

flexible sleeve is folded inward upon itself and removed from the glass fiber coil. This results in a considerable savings over methods that require a spindle, such as a cardboard spindle, that must be dedicated to each coil of glass fibers and are discarded after a single, or very few uses. Unlike cardboard spindles, the inventive sleeve can then be reused by the manufacturer, the number of uses only limited by the durability of the sleeve itself.

In operation, prior to or during the spinning operation, the manufacturing information relating to the material wound upon the sleeve is determined by a user. The information is loaded into the transmitter. The transmitter then transmits the information to the transponder in the sleeve. The information is stored in the memory portion of the transponder.

An interrogator at the point of use queries the transponder in the sleeve. In response to the interrogator signal, the transponder transmits the information loaded during manufacture which is descriptive of the particular material wound on the sleeve. The transponder is read without use of any optical reader, such as one would use with a bar-code reader. As noted, the transponder processor has a read/write capability that allows the sleeve to be used repeatedly.

Fig. 4 is a cross-sectional view of the inventive sleeve at 4-4 in Fig. 5. Transponder 200 is shown contained in pocket 101. Pocket 101 is formed of piece 102 between elastomeric layer 105 and tensile cords 107. Elastomeric layer 108 comprises an undercord layer. The sleeve may have a toothed profile 109, see Fig. 5, to enhance engagement between the sleeve and a mandrel portion. The sleeve may also omit a toothed profile, or

have a toothed profile on a side opposite that shown in Fig. 5.

Although a single form of the invention has been described herein, it will be obvious to those skilled in the art that variations may be made in the construction and relation of parts without departing from the spirit and scope of the invention described herein.

Claims

I claim:

1. A data system comprising:

5 an elastomeric product having a receiving portion  
cured therein;

a transponder circuit comprising a processor and  
signal antenna for interaction with a remote  
electrical device; and

10 the transponder circuit sealed into said receiving  
portion.

2. The data system as in claim 1 further comprising:

an interrogator unit for signaling the transponder  
to receive or transmit product information.

3. The data system as in claim 1 wherein the  
transponder circuit comprises:

a memory portion for storing product information;

20 a receiver for receiving a signal from the  
interrogator; and

a transmitter for accessing and transmitting  
information stored in the memory portion.

4. The data system as in claim 1, wherein the  
25 transponder is sealed into the receiving portion by  
an adhesive.

5. The data system as in claim 1, wherein the receiving  
portion further comprise a piece that binds to an  
30 elastomeric on a single side during a vulcanization  
process.

6. The data system as in claim 5, wherein the piece comprises a flexible and non-metallic material.

7. A sleeve comprising:

5

an elastomeric body;

a receiving portion formed in the elastomeric body;

and

the receiving portion having a shape suitable for receiving an electronic data logger.

10

8. The sleeve as in claim 7, wherein the receiving portion further comprises:

a material bondable only to the elastomeric.

15

9. The sleeve as in claim 8, wherein the electronic data logger further comprises:

a transponder sealed within the receiving portion after a vulcanization of the elastomeric body; and

the transponder comprising a data receiving portion,

20

a data storage portion and a data transmitting portion.

10. The sleeve as in claim 9, wherein the transponder is moveable within the receiving portion.

25

11. The sleeve as in claim 10, wherein the transponder comprises a thickness less than 2mm.

12. The sleeve as in claim 10 further comprising tensile cords wound in the elastomeric body in a longitudinal direction.

30

13. The sleeve as in claim 10, wherein the receiving portion is sealable.

5 14. The sleeve as in claim 13, wherein the receiving portion is radially outward from a tensile cord.

15. The sleeve as in claim 14 further comprising a toothed profile.

10 16. A method of manufacturing spun material comprising the steps of:

using a sleeve having a pocket for moveably containing an electronic data logging device; and

15 transmitting a data to the electronic data logging device as part of a winding process for forming a spun material coil; and

receiving a data from the electronic data logging device.

20 17. The method as in claim 16 further comprising the step of:

storing the data in a memory portion of the electronic data logging device.

25 18. The method as in claim 17 further comprising the step of removing the sleeve from a spun material coil.

30 19. The method as in claim 17 further comprising the step of sealing the pocket.

20. The method as in claim 16 further comprising the step of mounting the electronic data logger device to a flexible non-metallic material.

## AMENDED CLAIMS

[Received by the International Bureau on 26 March 2003 (26.03.03):  
original claims 1-20 replaced by amended claims 1-20 ]

Claims

I claim:

1. A data system comprising:
  - an elastomeric product having a receiving portion cured therein;
  - a transponder circuit comprising a processor and signal antenna for interaction with a remote electrical device;
  - the transponder circuit sealed into said receiving portion; and
  - wherein the receiving portion further comprise a piece that binds to an elastomeric on a single side during a vulcanization process.
2. The data system as in claim 1 further comprising:
  - an interrogator unit for signaling the transponder to receive or transmit product information.
3. The data system as in claim 1 wherein the transponder circuit comprises:
  - a memory portion for storing product information;
  - a receiver for receiving a signal from the interrogator; and
  - a transmitter for accessing and transmitting information stored in the memory portion.
4. The data system as in claim 1, wherein the transponder is sealed into the receiving portion by an adhesive.
5. Cancelled.
6. The data system as in claim 1, wherein the piece comprises a flexible and non-metallic material.

7. A sleeve comprising:
  - an elastomeric body;
  - a receiving portion formed in the elastomeric body;
  - and
  - the receiving portion having a shape suitable for receiving an electronic data logger.
8. The sleeve as in claim 7, wherein the receiving portion further comprises:
  - a material bondable only to the elastomeric.
9. The sleeve as in claim 8, wherein the electronic data logger further comprises:
  - a transponder sealed within the receiving portion after a vulcanization of the elastomeric body; and
  - the transponder comprising a data receiving portion, a data storage portion and a data transmitting portion.
10. The sleeve as in claim 9, wherein the transponder is moveable within the receiving portion.
11. The sleeve as in claim 10, wherein the transponder comprises a thickness less than 2mm.
12. The sleeve as in claim 10 further comprising tensile cords wound in the elastomeric body in a longitudinal direction.
13. The sleeve as in claim 10, wherein the receiving portion is sealable.

14. The sleeve as in claim 13, wherein the receiving portion is radially outward from a tensile cord.

15. The sleeve as in claim 14 further comprising a toothed profile.

16. A method of manufacturing spun material comprising the steps of:

using a sleeve having a sealed pocket for moveably containing an electronic data logging device;

transmitting a data to the electronic data logging device as part of a winding process for forming a spun material coil; and

receiving a data from the electronic data logging device.

17. The method as in claim 16 further comprising the step of:

storing the data in a memory portion of the electronic data logging device.

18. The method as in claim 17 further comprising the step of removing the sleeve from a spun material coil.

19. Cancelled.

20. The method as in claim 16 further comprising the step of mounting the electronic data logger device to a flexible non-metallic material.

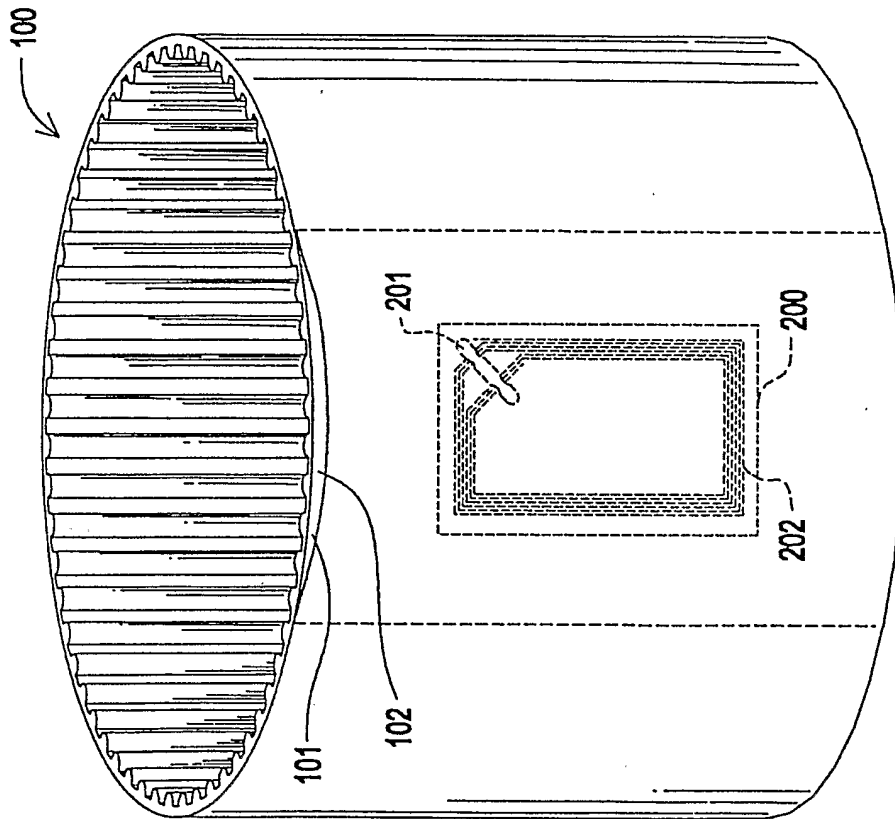

FIG.1

2/3

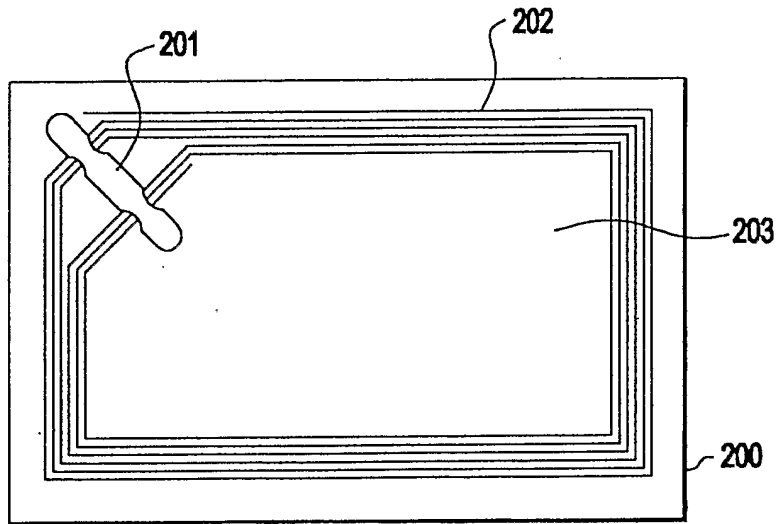

FIG. 2

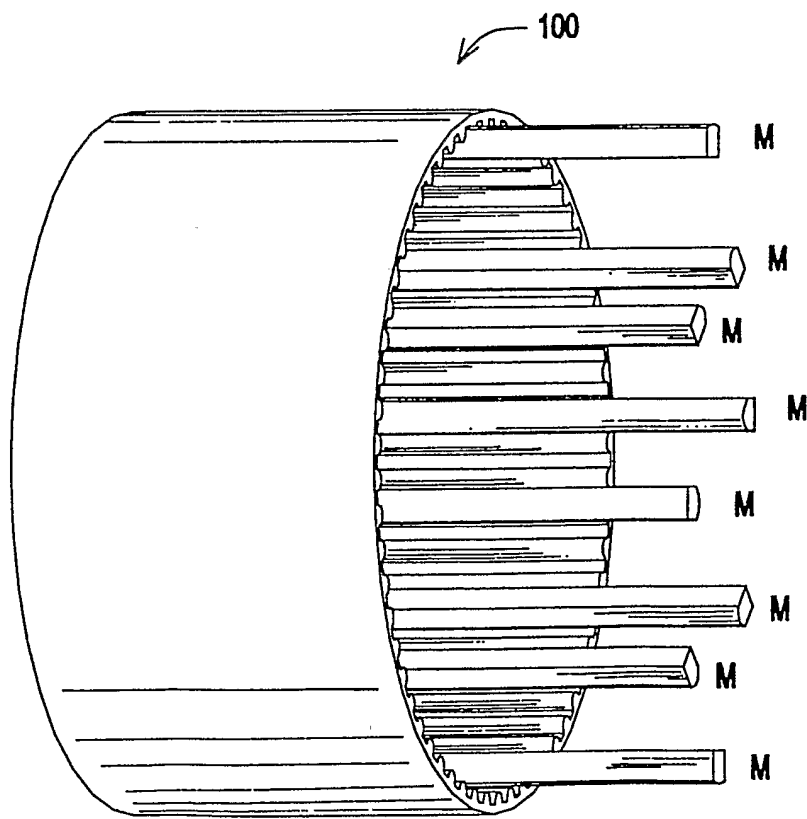
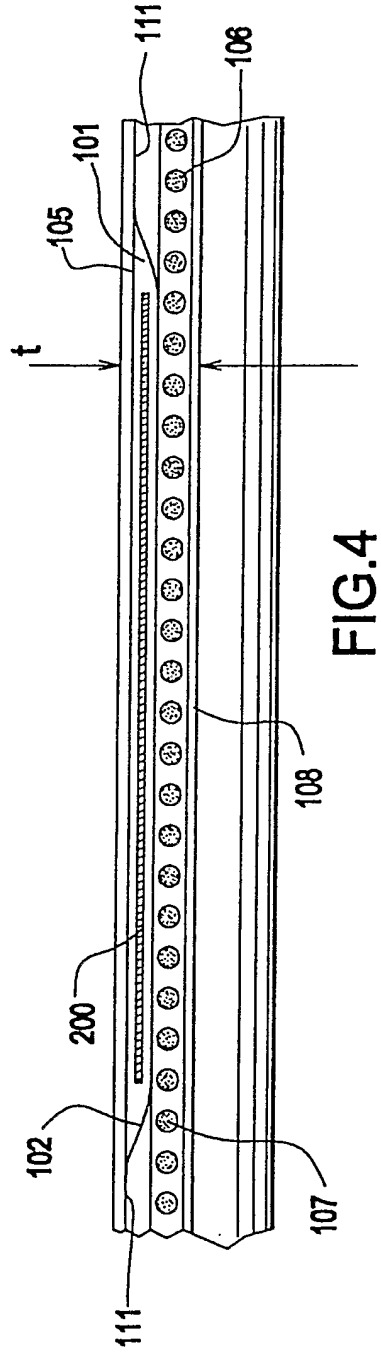
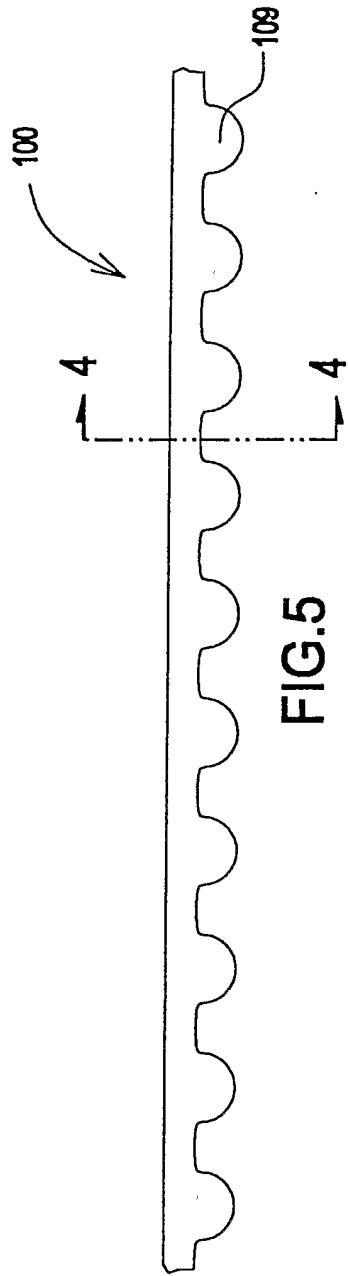

FIG. 3



INTERNATIONAL SEARCH REPORT

International Application No  
PCT/US 02/37900

**A. CLASSIFICATION OF SUBJECT MATTER**  
IPC 7 G06K19/07 G06K19/04 B65H75/18

According to International Patent Classification (IPC) or to both national classification and IPC

**B. FIELDS SEARCHED**  
Minimum documentation searched (classification system followed by classification symbols)  
IPC 7 G06K B65H

Documentation searched other than minimum documentation to the extent that such documents are included in the fields searched

Electronic data base consulted during the international search (name of data base and, where practical, search terms used)  
EPO-Internal, WPI Data, PAJ

**C. DOCUMENTS CONSIDERED TO BE RELEVANT**

Category °	Citation of document, with indication, where appropriate, of the relevant passages	Relevant to claim No.
X	DE 299 03 840 U (DIALOG TEXTIL BEKLEIDUNG) 22 July 1999 (1999-07-22) page 6, paragraphs 1-4; figures 2A,2B,2C ----	1-4,7,8, 16,17
X	EP 0 398 301 A (STAR MFG CO) 22 November 1990 (1990-11-22) column 2, line 53 -column 4, line 13 ----	1,7,16
X	WO 98 28213 A (ROEDER KLAUS WALTER ;KOENIG & BAUER ALBERT AG (DE)) 2 July 1998 (1998-07-02) page 3, paragraphs 2,3 ----	1,7
A	FR 2 697 801 A (ALLIBERT EQUIPEMENT) 13 May 1994 (1994-05-13) page 4, line 17 -page 6, line 26; figures 2,3 -----	16
A		1,7,16

Further documents are listed in the continuation of box C.  Patent family members are listed in annex.

° Special categories of cited documents :

*A* document defining the general state of the art which is not considered to be of particular relevance	*T* later document published after the international filing date or priority date and not in conflict with the application but cited to understand the principle or theory underlying the invention
*E* earlier document but published on or after the international filing date	*X* document of particular relevance; the claimed invention cannot be considered novel or cannot be considered to involve an inventive step when the document is taken alone
*L* document which may throw doubts on priority claim(s) or which is cited to establish the publication date of another citation or other special reason (as specified)	*Y* document of particular relevance; the claimed invention cannot be considered to involve an inventive step when the document is combined with one or more other such documents, such combination being obvious to a person skilled in the art.
*O* document referring to an oral disclosure, use, exhibition or other means	*Z* document member of the same patent family
*P* document published prior to the international filing date but later than the priority date claimed	

Date of the actual completion of the international search  28 February 2003	Date of mailing of the international search report  11/03/2003
---	--

Name and mailing address of the ISA European Patent Office, P.B. 5818 Patentlaan 2 NL - 2280 HV Rijswijk Tel. (+31-70) 340-2040, Tx. 31 651 epo nl, Fax: (+31-70) 340-3016	Authorized officer  Schauler, M
--	---------------------------------------

**INTERNATIONAL SEARCH REPORT**  
Information on patent family members

International Application No  
PCT/US 02/37900

Patent document cited in search report		Publication date	Patent family member(s)	Publication date
DE 29903840	U	22-07-1999	DE 29903840 U1	22-07-1999
EP 0398301	A	22-11-1990	JP 2305233 A EP 0398301 A2	18-12-1990 22-11-1990
WO 9828213	A	02-07-1998	DE 19653814 A1 WO 9828213 A1 DE 59706138 D1 EP 0946403 A1 JP 2000506826 T US 6334587 B1	25-06-1998 02-07-1998 28-02-2002 06-10-1999 06-06-2000 01-01-2002
FR 2697801	A	13-05-1994	FR 2697801 A1	13-05-1994