

June 6, 1967

L. O. BODDY

3,323,846

DRY BOX GLOVE RETAINING MEANS

Filed March 25, 1965

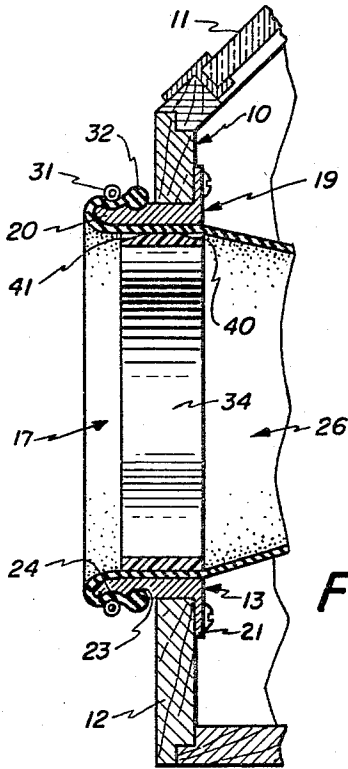

Fig. 1

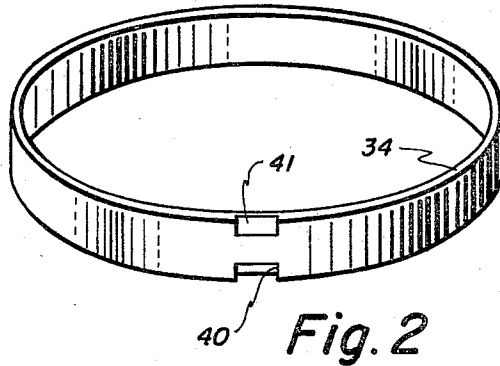

Fig. 2

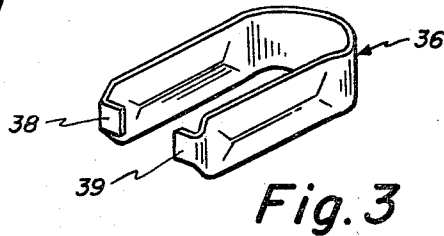

Fig. 3

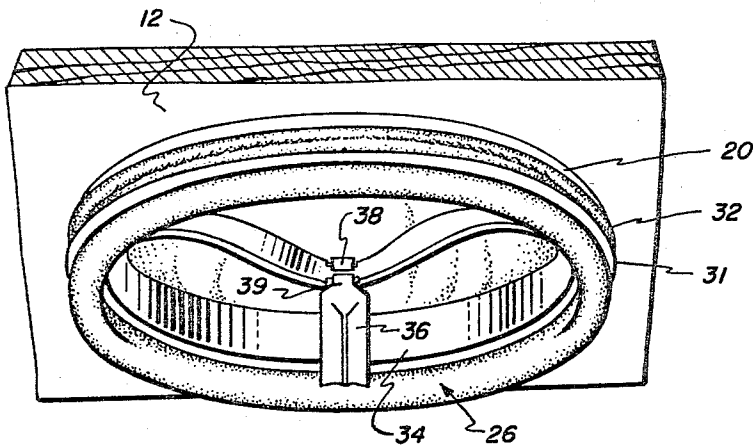

Fig. 4

INVENTOR.

Lawrence O. Boddy

BY

Robert A. Gaudin

ATTORNEY

1

3,323,846

DRY BOX GLOVE RETAINING MEANS

Lawrence O. Boddy, Westminster, Colo., assignor to the United States of America as represented by the United States Atomic Energy Commission
 Filed Mar. 25, 1965, Ser. No. 442,836
 3 Claims. (Cl. 312-1)

ABSTRACT OF THE DISCLOSURE

A plastic sealing band of continuous circumference fitting on the inner circumference of a ring defining the glove opening of a dry box and sealing the glove intermediate said band and ring, said band having a recessed surface on its outer circumference for engagement of a tool to facilitate inward deformation and removal thereof.

The present invention relates generally to dry boxes and more particularly to a continuous collapsible band means for sealing and retaining gloves against the inner surface of a dry box window glove ring and yet facilitating ready removal of the band.

Dry boxes and similar type enclosures may be advantageously utilized as confining or controlling work stations for hazardous materials, e.g., alpha emitters, low energy beta sources, biological preparations, and toxic materials. Oftentimes these enclosures may contain an inert atmosphere, such as argon gas, to enable the confinement and the working upon of particular materials in the enclosures.

In order to work upon or otherwise handle hazardous materials in any of the enclosures, access openings, glove ports, or glove windows are usually provided through a wall of the enclosure. These glove ports are, in turn, fitted with gloves which are secured in a fluid tight manner to the glove window ring surrounding the glove ports. Thus, a technician may reach into the enclosure and work upon the confined materials while being protected from the hazards of the confined materials by the gloves, and without adversely affecting an inert atmosphere in the enclosure.

Constructions for retaining the glove against the inner surface of the glove window ring as previously known suffer several shortcomings or drawbacks which render their use objectionable. For example, with these previous constructions a safety factor was involved in that they did not always readily fit properly so as to prevent radioactive products or other contaminants from creeping between the glove and the glove window ring to the outside of the glove ring and thereby create a contamination problem once the glove has to be changed. Another drawback was that a significant percentage of the gloves were damaged or punctured by being pinched between the ends of the retaining structures previously used. In addition to the above, hand injuries were sometimes incurred due to the metal constructions previously used.

Accordingly, an object of the present invention is to provide a new and improved glove band for retaining gloves against the inner surface of a dry box or similar type enclosure window ring.

Another object of the present invention is to provide means for facilitating removal of glove bands of the present invention from dry box window rings.

A further object of the present invention is to provide glove bands wherein a substantial savings in the cost of the glove bands and in the time required for installation and removal of the bands are realized.

A still further object of the present invention is to provide continuous glove bands capable of minimizing leak-

2

age of contaminants from within the dry box or similar type enclosure and in substantially reducing or obviating damage to gloves during glove band installation.

Other and further objects of the invention will be obvious upon an understanding of the illustrative embodiment about to be described, or will be indicated in the appended claims, and various advantages not referred to herein will occur to one skilled in the art upon employment of the invention in practice.

A preferred embodiment of the invention has been chosen for purposes of illustration and description. The preferred embodiment illustrated is not intended to be exhaustive nor to limit the invention to the precise form disclosed. It is chosen and described in order to best explain the principles of the invention and their application in practical use to thereby enable others skilled in the art to best utilize the invention in various embodiments and modifications as are best adapted to the particular use contemplated.

In the accompanying drawing:

FIG. 1 is a sectional view of a dry box or similar type enclosure showing the relationship of a glove to the enclosure with a preferred form of an inner glove retaining band of the present invention in place;

FIG. 2 is a perspective view of a preferred form of a glove retaining band of present invention;

FIG. 3 is a perspective view of a preferred form of an element that cooperates with the glove band of FIG. 2 in removal from a dry box window; and

FIG. 4 is a perspective view showing the improved means of the present invention appearing during removal from a dry box window ring.

With reference to FIG. 1 there is shown a glove box or dry box generally indicated at 10 that may be of any desired conventional construction. For example, the glove box 10 may comprise an enclosed space defined by a shell including a transparent viewing section 11, a panel 12 forming a portion of the shell beneath the transparent section and containing a pair of horizontally spaced glove windows, one of which is shown in section at 13. The glove box 10 may be attached to or include an air or gas supply and exhaust system (not shown) for maintaining the box interior at a pressure slightly less than ambient pressure, e.g., one-sixteenth of an inch of water, to minimize the passage of hazardous materials into the surrounding room through openings in the shell.

A glove window may comprise any suitable ring-like structure capable of adequately supporting and maintaining a glove in position with respect to a passageway extending through the glove window and communicating with the interior of the enclosure. Such a glove window may comprise a tubular metal ring 19 encircling the opening or passageway 17 and extending in a lateral direction away from the panel 12 such as to form an annular glove mounting and retaining lip or rim 20. The ring 19 may be formed as an integral part of the panel 12 or be attached thereto by bolting or otherwise securing an annular flange 21 of the ring 19 to the panel 12. The rim 20 may be provided with a circumferentially extending notch or groove 23 about the outer surface of the rim 20 for receiving a glove retaining member such as a bead of the glove or a band of elastic material as will be described in greater detail below. Oftentimes the rim 20 may be provided with another notch or groove 24 slightly spaced from the groove 23 such that both the bead of the glove and the band of elastic material may be utilized to secure the glove in place.

The gloves used in glove boxes and the like may be of any suitable material and of any desired length depending upon the particular use envisioned for the gloves.

Thus, the description of the gloves hereinafter set forth is merely an illustrative example of one type glove usable in a glove box and is not intended as limiting the invention to this particular glove arrangement. The gloves, one of which is shown in fragmentary form in FIG. 1 at 26 may be made of a rubber or rubber-like material such as neoprene and be of an overall length of about twenty-seven inches. Each glove may comprise a hand portion and a gauntlet or sleeve portion. The end of the sleeve portion remote from the hand portion may be provided with a bead of thickened neoprene or other material to aid in securing the glove to the glove port structure. In an unexpanded condition the bead, such as shown in FIG. 1 at 32 has a circumference less than the circumference of the rim 20 so that in order to place a glove over the rim 20 its bead must first be stretched to a circumference sufficient to pass over the rim surface. Consequently, when the bead is released after it is passed a desired distance onto the rim 20 it contracts into one of the grooves 23 or 24 and binds the glove to the rim in an air-tight or leak-proof manner.

In addition to a glove bead it may be desirable to affix the glove to the glove port structure in a more secure manner by placing a retaining band 31 (FIG. 1) about the outer surface of the glove sleeve portion adjacent the glove bead such that the band 31 clamps the glove material into the groove 24. The band 31 like the bead 32 is preferably of an elastic material and of dimensions less than that of the rim 20 such as to require stretching prior to placing it over the glove and rim.

With the glove mounted on the ring 20 as above described the inner glove band 34 of the present invention (FIG. 2) may be inserted into the glove 26 as to bear against the glove for forcing it against the inner surface of the glove ring 19. The glove band 34 maintains the glove against the inner surface of the glove ring 19 to assure that leakage of contaminants between the glove and the ring to the outer surface of the ring is minimal and also facilitates the admittance of a technician's hand into the glove. The glove band 34 is in the form of an uninterrupted or "unbroken" annulus or cylinder which has a generally rectangular cross-sectional configuration with the corners between the parallel inner and outer surfaces and the oppositely disposed edges or side surfaces being slightly rounded and is preferably molded or otherwise formed from polyethylene or polypropylene or from any other suitable plastic material. The circumferential dimensions of the continuous band 34 should be slightly less than the circumferential dimensions of the inner surface of the glove ring and at least equal to the inner circumferential dimensions of the adjacent glove portion to assure that the outer peripheral surface of the glove 26 is held against the inner peripheral surface of the ring. For example, with the opening through the ring 19 having a diameter of eight inches the outer diameter of the glove band should be about 7.95 inches.

To install the glove band 34 within the glove, the band may be temporarily deformed or collapsed such as by pulling one side towards the other or opposite side to decrease its effective diameter and then moved into place within the glove and released so that the band returns to its initial configuration to force the glove against the ring.

In order to facilitate deformation of the glove band 34 within the glove 26, such as occasioned by a glove changing, an element 36 (FIGS. 3 and 4) interengaging or carried with the band may be used by a technician to "collapse" or deform the band so that it may be readily pulled or removed from within the glove 26. This element 36 may be of relatively flexible thin material or metal, such as, for example, a 10.75 inch long by one inch wide piece of 16 gauge stainless steel or the like, that is bent at the middle about—say, a one and one-sixteenth inch radius into a generally U-shaped configuration. The body portion between the bight and the ends may be reinforced by providing a slight bow such as shown in FIG. 3. The por-

tion adjacent the ends thereof may be tapered—say at a 45 degree angle, from opposite edges towards the end to provide relatively narrow fingers 38 and 39 of about 0.375 of an inch in length, which may have rounded leading edges, may be bent towards each other about an angle of approximately 90 degrees to the bowed body portion so that the fingers may be positioned or retained between the band 34 and the glove 26 to enable a technician to pull the glove band 34 away from the glove 26 as shown in FIG. 4. While the finished element 36 may be about 4.5 inches long, it will appear clear that the tool may be shorter if desired.

To assure that the fingers 36 can be placed between the glove 26 and the band 34 without difficulty or without damaging the glove 26, the band 34 may be provided with gradually tapering outer surfaces defining oppositely disposed recessed surfaces or notches 40 and 41 in the outer surface thereof to facilitate the reception of the fingers 38 and 39. These notches 40 and 41, as shown in FIGS. 1 and 2, each preferably extend less than half the distance across the length of the band to assure that the band bears against the glove 26 about the full circumference of the band. While the notches may be of any suitable configuration, satisfactory results have been attained by tapering each of the notches so that the deepest part of the notch is at and interrupts the edge of the band 34 while the shallowest part of the notch is substantially common with the end of the notch remote to the band edge. Also, while the notches may be of desired circumferential dimension, they should have a minimum circumferential dimension greater than the width of the fingers 38 and 39 so as to enable the fingers to be readily placed into engagement with the notches. For example, with fingers about 0.375 of an inch wide and a band having a generally rectangular cross section with dimensions of about 1.25 inches in length, i.e., the longitudinal or width dimension of the band disposed parallel to the axis of rotation for said band, and about 0.125 of an inch in thickness, each notch may circumferentially extend about the band about 0.5 of an inch and about 0.25 of an inch across the length of the band with the deepest portion of the notch being about three-fourths the thickness of the band. The taper angle of a notch having the above dimensions may be about 20 degrees.

It will be seen that the glove band of the present invention provides a novel approach to the problems and expense incurred with the glove bands previously used in that the present glove band provides easier installation, greater safety, and is less expensive. Also, the cost of the present glove band is further reduced by the fact that thickness of the glove band need not be as great as the "broken" plastic glove bands previously employed.

As various changes may be made in the form, construction and arrangement of the parts herein without departing from the spirit and scope of the invention and without sacrificing any of its advantages, it is to be understood that all matter herein is to be interpreted as illustrative and not in a limiting sense.

I claim:

1. In combination with a dry box having a ring defining a glove opening and a glove sleeve portion within the confines of the ring and abutting at its outer periphery against an inner periphery of said ring, an endless self-supporting glove retaining and sealing band within said sleeve portion for abutting against the inner periphery thereof and maintaining said sleeve portion in firm engagement against said inner periphery of the ring, said endless band being of flexible readily inwardly deformable plastic material and having spaced apart marginal edges separated by a relatively wide outer surface contacting and sealing said sleeve portion over a correspondingly wide area and having at said outer surface facing toward said glove at least a pair of oppositely disposed sloping portions of gradually reducing thickness extending toward each other from locations communicating with said marginal edges and ter-

5

minating at locations spaced apart from each other with said sloping portions together occupying a distance not greater than half the distance across the band, said outer surface intermediate the terminating locations of said sloping portions providing throughout the circumference of the endless band a smooth sealing surface of width not less than half the distance across the band, said band being smooth and uninterrupted throughout its entire inner circumference.

2. The combination claimed in claim 1, wherein said plastic material is selected from the group consisting of polypropylene and polyethylene.

3. The combination as claimed in claim 1, wherein there is provided means in engagement with each of said sloping portions of gradually reduced thickness for facilitating inward deformation and removal of said band.

5

10

15

6

References Cited

UNITED STATES PATENTS

655,688	8/1900	Coleman et al. ---	285—321	X
1,177,338	3/1916	Kayfetz -----	285—338	X
1,211,349	2/1917	Prahl -----	285—162	X
2,314,315	3/1943	Scheele -----	285—239	X
2,366,067	12/1944	Smith -----	285—260	X
2,836,445	5/1958	Baudry -----	285—321	X
3,237,821	3/1966	Hayne et al. -----	2—270	X

FOREIGN PATENTS

498,073 9/1954 Italy.

CARL W. TOMLIN, *Primary Examiner*.

THOMAS F. CALLAGHAN, *Examiner*.