

(19) World Intellectual Property Organization
International Bureau



(43) International Publication Date
9 December 2004 (09.12.2004)

PCT

(10) International Publication Number
WO 2004/105660 A1

- (51) International Patent Classification⁷: **A61F 9/007**, 9/008, H01S 3/067, 3/094
- (21) International Application Number: PCT/IB2004/001781
- (22) International Filing Date: 28 May 2004 (28.05.2004)
- (25) Filing Language: English
- (26) Publication Language: English
- (30) Priority Data:
 - 60/475,583 2 June 2003 (02.06.2003) US
 - 10/625,797 23 July 2003 (23.07.2003) US
- (71) Applicants (for all designated States except US): **CARL ZEISS MEDITEC AG** [DE/DE]; Goeschwitzer Strasse 51-52, 07745 Jena (DE). **IMRA AMERICA, INC.** [US/US]; 1044 Woodridge Avenue, Ann Arbor, MI 48105 (US).
- (72) Inventors; and
- (75) Inventors/Applicants (for US only): **BENDETT, Mark** [US/US]; 2770 Gladstone, Ann Arbor, MI 48104 (US). **BISCHOFF, Mark** [DE/DE]; Am Bach 3, 99334 Elleben OT Riechheim (DE). **GERLACH, Mario** [DE/DE]; Klosterlausnitzer Strasse 14, 07607 Eisenberg (DE). **MUEHLHOFF, Dirk** [DE/DE]; Am Moenchenberge 2, 07751 Kunitz (DE).
- (74) Agent: **KIEL, Gerald, H.**; Reed Smith LLP, 599 Lexington Avenue, New York, NY 10022-7650 (US).
- (81) Designated States (unless otherwise indicated, for every kind of national protection available): AE, AG, AL, AM, AT, AU, AZ, BA, BB, BG, BR, BW, BY, BZ, CA, CH, CN, CO, CR, CU, CZ, DE, DK, DM, DZ, EC, EE, EG, ES, FI, GB, GD, GE, GH, GM, HR, HU, ID, IL, IN, IS, JP, KE, KG, KP, KR, KZ, LC, LK, LR, LS, LT, LU, LV, MA, MD, MG, MK, MN, MW, MX, MZ, NA, NI, NO, NZ, OM, PG, PH, PL, PT, RO, RU, SC, SD, SE, SG, SK, SL, SY, TJ, TM,

[Continued on next page]

(54) Title: APPARATUS AND METHOD FOR OPHTHALMOLOGIC SURGICAL PROCEDURES USING A FEMTOSECOND FIBER LASER

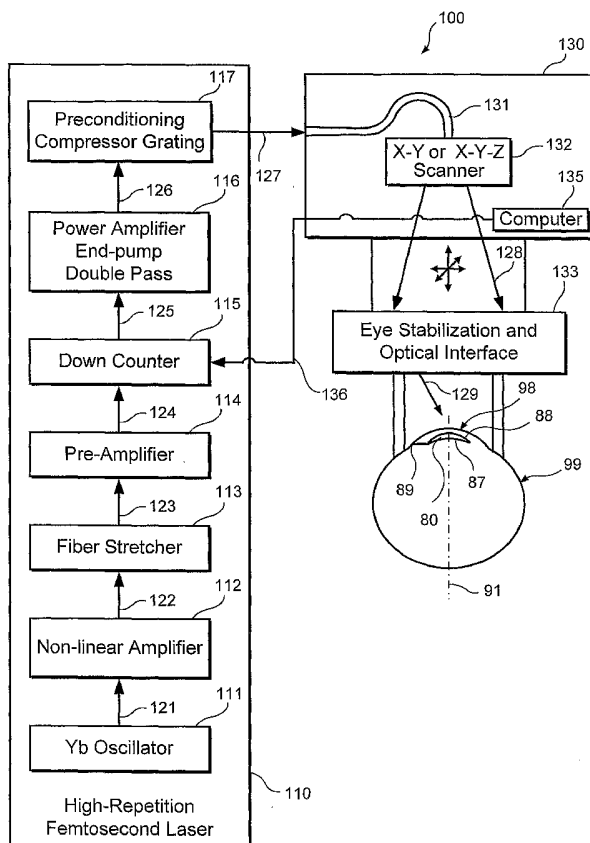

(57) Abstract: Apparatus and method to generate a stream of pulses having a pulse repetition rate of at least about 50000 pulses per second and a per-pulse length of less than one picosecond, and to scan and focus the stream to an output light pattern suitable to sculpt tissue for a surgical procedure (e.g., ophthalmologic) using at least a high number of pulses to complete the operation in a matter of a few seconds, e.g., 100000 pulses in less than ten seconds. Some embodiments create a preconditioning negative dispersion that compensates for positive dispersion in the scanning system, in some embodiments; a lenticule is cut using the laser and scanning system and is mechanically removed through a side slit formed through the cornea surface.

WO 2004/105660 A1



TN, TR, TT, TZ, UA, UG, US, UZ, VC, VN, YU, ZA, ZM, ZW.

SK, TR), OAPI (BF, BJ, CF, CG, CI, CM, GA, GN, GQ, GW, ML, MR, NE, SN, TD, TG).

(84) Designated States (*unless otherwise indicated, for every kind of regional protection available*): ARIPO (BW, GH, GM, KE, LS, MW, MZ, NA, SD, SL, SZ, TZ, UG, ZM, ZW), Eurasian (AM, AZ, BY, KG, KZ, MD, RU, TJ, TM), European (AT, BE, BG, CH, CY, CZ, DE, DK, EE, ES, FI, FR, GB, GR, HU, IE, IT, LU, MC, NL, PL, PT, RO, SE, SI,

Published:

— *with international search report*

For two-letter codes and other abbreviations, refer to the "Guidance Notes on Codes and Abbreviations" appearing at the beginning of each regular issue of the PCT Gazette.

APPARATUS AND METHOD FOR OPHTHALMOLOGIC SURGICAL PROCEDURES USING A FEMTOSECOND FIBER LASER

Related Application

[0001] This claims priority to U.S. Provisional Patent Application No. 60/475,583 filed June 2, 2003 and U.S. Non-Provisional Patent Application No. 10/625,797 filed July 23, 2003, both entitled APPARATUS AND METHOD FOR OPTHALMOLOGIC SURGICAL PROCEDURES USING A FEMTOSECOND FIBER LASER, the complete disclosure of which are incorporated in its entirety by reference.

Field of the Invention

[0002] This invention relates to the field of surgical laser tools, and more specifically to a method and apparatus for ophthalmologic surgical procedures using a femtosecond fiber laser.

Background of the Invention

[0003] Laser-based apparatus for refraction-correction ophthalmologic surgery, such as the-LASIK (laser in situ keratomileusis) procedure, can correct various vision impairments such as myopia (i.e. near-sightedness), hyperopia (i.e. farsightedness) and astigmatism by surgically reshaping the cornea of the eye.

[0004] Hyperopia is measured in terms of positive diopters. Myopia is measured in terms of negative diopters. The most common refractive errors ranged between +6 to -6 diopters. For example, if part of the corneal stroma (the interior bulk of the cornea) is removed, the created void can be made to close. The result is a reshaped cornea.

[0005] Conventionally, LASIK procedures use a mechanical knife, called a keratome, to create a flap. The mechanical flap-creation procedure can damage the cornea and stroma tissue, possibly requiring an extended healing period and leaving undesirable artifacts such as haze, scarring, and/or instability of the correction, which interfere with vision in some cases.

[0006] Further, once the flap is created and folded back, conventional LASIK

procedures typically use a high-powered ultraviolet excimer laser to photoablate a pattern (e.g., of spots) to reshape the stroma. Such a process is relatively crude, due to the relatively large size of the spots and possibly due to heating and acoustic shockwaves from the excimer photoablation. That is, the relatively coarse granularity of the excimer laser procedure and its higher energy pulses leaves something to be desired. After shaping the stroma, the flap is repositioned to complete the surgery.

[0007] As described in U.S. Patent 6,110,166 issued August 29, 2000 entitled "Method for corneal laser surgery" (and incorporated herein by reference), a LASIK-type surgery procedure can be made more effective and efficient if the flap that is created can be repositioned in an interlocking relationship with the undisturbed corneal tissue. A flap with an interlockable configuration can be created. The flap could then be lifted to expose the corneal tissue that is to be removed and, next, after the desired amount of corneal tissue is removed, the flap could be repositioned and interlocked with undisturbed corneal tissue to hold the flap in place during the healing process. The use of laser systems for ophthalmic surgical procedures, such as for other procedures contemplated for the present invention, is particularly appropriate due to the extreme precision required when corneal tissue is to be removed. Depending on the diameter and the general shape of the tissue volume to be removed, the removal of a layer of stromal tissue that is only approximately ten microns thick can result in a one diopter change. The removal of a lens shaped volume of tissue that is four millimeters in diameter and approximately fifty microns thick at its center can result in a refractive correction of approximately four diopters. Thus, for vision corrections to achieve accuracy within one-diopter, the surgical procedure employed must be capable of precisely removing corneal tissue having a thickness which is accurate to within less than ten microns. Further, this degree of accuracy applies for any refractive correction regardless of the total amount of correction required.

[0008] The correction of myopia requires removal of a volume of corneal tissue having a different shape than does the correction of hyperopia. Also, the limits of potential correction are different. For a myopic correction, a lentoid or lens-shaped volume of stromal tissue is removed. At the present time, myopic corrections of up

to approximately thirty diopters can be reasonably expected. On the other hand, corrections of hyperopic conditions can be made up to only about fifteen diopters. Furthermore, for a hyperopic correction the volume of stromal tissue that is removed is thicker towards the edges than in the center.

[0009] Conventional femtosecond laser apparatus for eye surgery takes a relatively long time to form the cuts, typically in the order of one minute, during which time the eye must be held in a fixed position in order that the cuts are contiguous and formed in the shape that was predefined.

[0010] There is thus a need for an improved apparatus for fast refraction-correction ophthalmologic surgery in order to change the corneal curvature in a controlled way without affecting the corneal clarity or the integrity of the various membranes surrounding the stroma.

Summary of the Invention

[0011] The present invention provides a high-repetition rate femtosecond laser coupled to a high-speed scanner, which results in a finer granularity in forming cuts in the stroma of the eye, and a much shorter duration of the surgical procedure, thus reducing the chance that the eye could move during the operation.

[0012] In some embodiments, the individual spots are created in a pattern wherein temporally sequential pulses are in a spaced-apart configuration in the stroma, in order to reduce the cumulative heating of and/or shock to local areas. For example, most or all spots can be formed wherein temporally adjacent pulses are used to create spots having a spacing at least two times the spot-to-spot spacing of spots in the array.

Brief Description of the Drawings

[0013] FIG.1 shows a schematic view of an apparatus 100 according to one embodiment of the present invention.

[0014] FIG.2 is a plan view of a scan pattern 200 for an array of spots;

[0015] FIG.3 is a plan view of a scan pattern 300 for an array of spots;

[0016] FIG.4A is a side cross-section view of an eye 99 after a flap cut 77;

[0017] FIG.4B is a front view of the eye 99 of FIG.4A;

- [0018] FIG.5A is a side cross-section view of an eye 99 after a posterior lenticule cut 78;
- [0019] FIG.5B is a front view of the eye 99 of FIG.5A.;
- [0020] FIG.6A is a side cross-section view of an eye 99 after the flap has been resealed;
- [0021] FIG.6B is a front view of the eye 99 of FIG.6A;
- [0022] FIG.7A is a side cross-section view of an eye 99 after two lenticule cuts;
- [0023] FIG.7B is a front view of the eye 99 of FIG.7A;
- [0024] FIG.8A is a side cross-section view of an eye 99 as lenticule 80 is removed;
- [0025] FIG.8B is a front view of the eye 99 of FIG.8A;
- [0026] FIG.9A is a side cross-section view of an eye 99 after the cornea surface layer has been resealed;
- [0027] FIG.9B is a front view of the eye 99 of FIG.9A; and
- [0028] FIG.10 is a side cross-section view of the eye 99 of FIG.1, showing more details.

Description of Preferred Embodiments

[0029] In the following detailed description of the preferred embodiments, reference is made to the accompanying drawings that form a part hereof, and in which are shown by way of illustration specific embodiments in which the invention may be practiced. It is understood that other embodiments may be utilized and structural changes may be made without departing from the scope of the present invention.

[0030] The leading digit(s) of reference numbers appearing in the Figures generally corresponds to the Figure number in which that component is first introduced, such that the same reference number is used throughout to refer to an identical component which appears in multiple Figures. Signals and connections may be referred to by the same reference number or label, and the actual meaning will be clear from its use in the context of the description.

[0031] The use of femtosecond laser pulses allows the laser-induced optical breakdown (LIOB) spot size to be drastically reduced, and thus a smoother shape can be obtained. (See Juhasz et al. "CORNEAL REFRACTIVE SURGERY WITH

FEMTOSECOND LASERS", IEEE Journal of Selected Topics in Quantum Electronics, Vol. 5, No. 4, July/August 1999, which is incorporated herein by reference). The tissue effects are achieved by plasma formation that results from applying a sufficient fluence (energy/area) to reach a threshold, and thus destroy tissue in the focal volume. This creates a very small cavitation bubble, however a large number of such spots next to one another can form a quite-precise plane or curved surface. In fact, the traditional keratome knife can be replaced by using an array of closely spaced LIOB spots to create a cut, and a smoother surface can be achieved using sufficiently small focused laser spots in a well-controlled pattern. However, a larger number of laser pulses are required to cover a given area with spots having the smaller spot size.

[0032] Nanosecond lasers require a relatively large energy (on the order of one or more millijoules per pulse) to achieve threshold fluence for photodisruption. The large energy then causes undesirable secondary effects such as heating, large cavitation bubbles and/or shockwaves to the surrounding tissues. Decreasing the pulse duration to the femtosecond range significantly reduces threshold fluence, and also significantly reduces shockwave damage and heating.

[0033] With conventional ophthalmologic machines, femtosecond pulsed lasers operating in the range of 5000 pulses per second are used and a field of 100,000 to 300,000 or more pulses can be needed to effect each ophthalmologic cut. It can take up to a minute or more to complete a laser-based cut or series of cuts using these slow pulse rates. Some way is therefore required to hold the eye motionless for that approximately minute-long procedure. For that purpose, various techniques and procedures have been devised, such as holding the eyeball with a suction-activated ring fitted circumferentially around the edge of the cornea for the duration of the operation. Even so, some researchers have reported experiencing loss of immobilization in up to two percent of the eyes operated on. Such complications can result in having to undergo multiple operations, or possibly in loss of vision due to cutting the wrong area of the eye.

[0034] Figure 1 shows a schematic view of an apparatus 100 according to one embodiment of the present invention. Apparatus 100 includes a laser system 110 and a scanner system 130. Laser system 110 produces outputted laser pulses at a

high repetition rate (e.g., from 50,000 to 1,000,000 pulses per second or more are output, although a much higher rate of pulses is originally generated internally in some embodiments). The pulses have a pulse shape and dispersion preconditioning such that once passed through scanning system 130, the light will produce femtosecond pulses (i.e., as used herein, these are pulses each having a duration of less than one picosecond, meaning pulses between about one femtosecond and about 999 femtoseconds). In some embodiments, each pulse is focused to a very small volume (e.g., about 1 micron by 1 micron by 1 micron, in some embodiments) to cause a femtosecond photodisruption event. By choosing a short pulse duration (e.g., in some embodiments, a 350-femtosecond duration) and small focal size (e.g., 5 microns or less), a very precise surface can be formed by an array of photodisruption-volume spots (herein called "spots"). In some embodiments, the energy of each pulse as it leaves laser system 110 is about two microJoules, and after passing through scanning system 130, is about one microJoule as it reaches the eye 99.

[0035] Apparatus 100 generates a scanned pulsed laser beam 129 directed onto an eye 99 of a patient. In some embodiments, laser section 110 includes one or more sections that have a fiber optical gain medium used to initially create the stream of very short optical pulses, or to amplify the pulses, or to condition, select (i.e., allow some pulses to go through and eliminate other pulses), and/or shape the temporal and/or spatial characteristics of the pulses. The fiber optic gain sections are typically pumped with optical energy having a shorter wavelength than the wavelength of the laser light, in order to create an inverted population of lasing species. In some embodiments, the laser section 110 is capable of generating a pulsed laser beam 127 having physical characteristics similar to those of the laser beams generated by a laser system as disclosed and claimed in U.S. Patent No.6,249,630 (incorporated herein by reference), which is also assigned to the assignee of the present invention. Furthermore, the present invention contemplates the use of a scanned pulsed laser beam 129 which has pulses with durations as long as a few picoseconds or as short as only a few femtoseconds.

[0036] As shown in more detail in Figure 10, the anatomical structure of eye 99

includes cornea 98 anterior to the pupil 95, the iris 96, and the sclera 92. Optical axis 91 of eye 99 passes through the cornea 98. The tissue of cornea 98 is transparent to visible and near-infrared light. Going in a direction from top (anterior of cornea 98) to bottom (posterior of cornea 98) in Figure 10, the tissue layers of the cornea include the epithelium 981, Bowman's membrane 982 (5-10 microns thick), stroma 983, Decemet's membrane 984 (5 microns thick), and endothelium 985. In some embodiments, the stroma 983 is most important for the present invention, as it contains the only tissue that is removed for correction of the patient's vision.

[0037] As indicated above, the correction for myopia, hyperopia, and/or astigmatism can be accomplished by the removal of a predetermined volume of stromal tissue. The particular volume and shape of stromal tissue to be removed for the correction of myopia depends on the type and amount of correction required. To correct myopia, a lens-shaped (lentoid) volume is removed. Such a lentoid volume 80 is shown in cross-section in Figures 1 and 10. The lentoid volume 80 is defined by an anterior surface 88 and a posterior surface 87. Together, the anterior surface 88 and the posterior surface 87 completely enclose and separate the lentoid volume 80 of stromal tissue 983 that is to be removed from the rest of the stroma. To obtain the lens shape of the lentoid volume 80 for myopic correction, anterior surface 88 may be convex in shape and the posterior surface 87 may be planar, convex, or concave in shape.

[0038] In some embodiments, a corneal-aplanation device such as described in U.S. Patent No.6,254,595 issued July 3, 2001 (and incorporated herein by reference) is used to aplanate (flatten) the anterior surface of the cornea for at least a portion of the surgical procedure, in order to reduce coma and/or spherical aberration of the focused laser spot. Further, this allows the anterior surface 88 to be cut as parallel to the flat contact surface of the aplanating lens, and then the cornea and the anterior surface 88 will restore to a curved shaped when the aplanating lens is removed.

[0039] This is useful for making a flap for LASIK procedures, but would require a custom-made curved contact lens (rather than other contact lens) to make a cut that is not conforming to a surface equidistant to the cornea surface when completed.

[0040] In other embodiments, a curved contact lens 1010, such as shown in Figure

10, is used instead of a planar contact lens, in order to reduce excess pressure on the cornea, which can cause undesirable secondary effects like glaucoma. In these embodiments, the scanner optics precompensates for the combined optical effects of contact lens 1010 and cornea 98 to reduce or eliminate coma and spherical aberration. Further, three-dimensional shapes can be cut, allowing much better correction of astigmatism, and a better corneal surface shape of the final result. Note that as a laser pulse is shortened, its bandwidth (i.e., range of colors) increases, and the optics of Scanner system 130, in some embodiments, is corrected for spherical aberration that would otherwise smear the focus of the light, with some colors focused too near and other colors focused too far.

[0041] In some embodiments, a cleaning device such as described in U.S. Patent No. 6,344,040 issued February 5, 2002 (and incorporated herein by reference) is used to aspirate resulting gas and debris from the surgical procedure.

In other embodiments, a saline flush is directed, for example, either freehand or from tubing attached to the frame of scanning system 130.

[0042] In some embodiments, a laser system 110 is built according to the teaching of U.S. Patent 6,249,630 (incorporated herein by reference) by Stock et al, issued June 19, 2001 and assigned to one of the assignees of the present invention.

[0043] Referring to Figure 1, in some embodiments, a Yb oscillator 111 such as a passively modelocked fiber laser, generates a series of optical pulses (a pulse stream) 121. In some embodiments, the pulses of optical pulse stream 121 have a wavelength of 1050 nm, a bandwidth of 2.5 nm, a pulse length of 1.5 ps, a power of 10 mW, a pulse rate of 50 MHz (i.e., 50,000,000 pulses per second), and a per-pulse energy of 0.2 nJ. Since the wavelength centered at 1050 nm in these embodiments is in the infrared (visible light being about 400 nm (blue-violet) to 700 nm (red)), there is less chance of startling the patient or causing stress and discomfort during the procedure than if visible light were used.

[0044] In some embodiments, pulse stream 121 is amplified by non-linear fiber amplifier 112 to generate pulse stream 122, which has a wavelength of 1050 nm, a bandwidth of 20 nm, a pulse length of 1.5 ps, a power of 60 mW, a pulse rate of 50 MHz (i.e., 50,000,000 pulses per second), and a per-pulse energy of 1.2 nJ.

[0045] I.e., pulse stream 122 is conditioned by fiber pulse stretcher 113 to

generate pulse stream 123, which has a wavelength of 1050 nm, a bandwidth of 20 nm, a pulse length of 200 ps, a power of 1 mW, and a pulse rate of 50 MHz (i.e. 50,000,000 pulses per second).

[0046] In some embodiments, pulse stream 123 is amplified by fiber pre amplifier 114 to generate pulse stream 124, which has a wavelength of 1050 nm, a bandwidth of 15 nm, a pulse length of 150 ps, a power of 500 mW, a pulse rate of 50 MHz (i.e., 50,000,000 pulses per second), and a per-pulse energy of 10 nJ.

[0047] In some embodiments, pulse stream 124 is decimated (i.e., all but selected pulses are removed) by downcounter 115 (e.g., in some embodiments, an acousto-optic modulator) to generate pulse stream 125, which has a wavelength of 1050 nm, a bandwidth of 15 nm, a pulse length of 150 ps, a power of 0.7 mW, and a pulse rate of 200 KHz (i.e., 200,000 pulses per second).

[0048] In some embodiments, pulse stream 125 is amplified by fiber power amplifier 116 to generate pulse stream 126, which has a wavelength of 1050 nm, a bandwidth of 10 nm, a pulse length of 100 ps, a power of 800 mW, and a pulse rate of 200 KHz (i.e., 200,000 pulses per second).

[0049] In some embodiments, pulse stream 126 is pre-conditioned by grating compressor 117 to generate pulse stream 127, which has a wavelength of 1050 nm, a bandwidth of 10 nm, a pulse length of 350 fs, a power of 400 mW, a pulse rate of 200 KHz (i.e., 200,000 pulses per second), and a per-pulse energy of 2.0 microJoules. Grating compressor 117 not only recompresses the pulse stretching from fiber pulse stretcher 113 and the other optics internal to laser system 110, but also precompresses (provides dispersion that is the same magnitude and opposite sign) for the dispersion of the optical path through scanner system 130.

[0050] In some embodiments, scanner system 130 and laser system 110 are packaged as a single integrated unit, as viewed from the outside.

[0051] In some embodiments, scanner system 130 includes an input optical path 131 (such as an optical fiber) and an X-Y (two dimensional) or X-Y-Z (three-dimensional) scanner 132 controlled by computer 135 to generate 3D scan pattern 128 that, when passed through the optical interface portion of eye-stabilization and optical interface 133, creates the desired pattern of spots. Scanner 132 also includes compensation optics that, when combined with the optical path inside Scanner 132 and

the optical path in eye-stabilization and optical interface 133, forms well-focused spots within the stroma of cornea 98.

[0052] In some embodiments, computer 135 also outputs control signal 136 that controls the timing of each pulse. E.g., when a slightly longer time is needed to move the scanning mechanics of scanner 132, the corresponding pulse can be delayed by control signal 136 to the desired time.

[0053] In some embodiments, a procedure, called herein femtosecond lamellar keratoplasty (FLK) is performed. FLK uses an array of individual photodisruption spots to define a lens-shaped block of tissue (a "lenticule") that is removed from the stroma through a side incision or from the surface of stroma exposed by a folded-back flap. A conventional procedure using a microkeratome is referred to as "automated lamellar keratoplasty", or ALK. The precision and flexibility associated with femtosecond photodisruption allows FLK to compete favorably and directly with LASIK. Many variations on this procedure are possible. A first cut 87 (planar, convex or concave) is made inside the cornea, defining the lenticule posterior surface. A second cut 88 (usually convex) is made defining the lenticule anterior surface. This cut may be extended to form a slit 89, or extended circumferentially further to form a flap to allow fuller access. Through the slit, or after the flap is lifted, the lenticule is then removed with hand instruments. Then the flap is replaced to form the new cornea shape, resulting in a direct refractive correction.

[0054] Figure 2 is a plan view of a scan pattern 200 for an array of spots according to some embodiments of the invention. In the embodiment shown, adjacent scan pattern 200 forms a spiral, wherein each temporally successive laser pulse forms a spot that adjoins the just previous spot. Reference numbers 1 through 22 represent the temporal order in which the spots are formed. Other similar embodiments use a Cartesian scan pattern (where each successive X-value is from a temporally successive pulse across an entire Y line, and then the next adjacent Y line is scanned (like the pattern of a progressive-scan TV scan pattern)). These adjacent scan patterns are advantageous where slight eye movement may be expected, since only very small incremental changes in height due to movement of the eye will occur between successive spots, and minor changes will occur between successive lines.

However there can be artifacts caused by accumulated heat from large numbers of spots formed in a small area in a small amount of time.

[0055] Figure 3 is a plan view of a scan pattern 300 for an array of spots. Hopping scan pattern 300 forms spaced-apart spots with successive laser pulses, i.e., successive pulses are scanned to spaced-apart spot locations, both in the X and Y directions, and later pulses fill in the intermediate spots later in the operation. In the embodiment shown, reference numbers 1 through 22 again represent the temporal order in which the spots are formed. After forming spot 1 in the lower left, two spot locations are skipped, and spot 2 is formed in the third spot over, next to the lower right. Spot 3 is then formed at the left of the middle line, spot 4 near the middle, and spot 5 towards the right. Note that each spot is moved to some minimal distance that is a multiple (>1) of the final spatial spot-to-spot spacing from the prior spot formed. In this example the spot 8 and spot 15 are located between spot 1 and spot 2, but are formed at a much later time (e.g., after spots 7 and 14, respectively, on the top line). In other embodiments, other spatial spacings for successive temporal pulses are used, for example, 10 spots, 20 spots, 50 spots, 100 spots, or other values. For example, some embodiments use a 100-spot spacing on a Cartesian grid of say, 500 spots by 500 spots, wherein the 1st, 101st, 201st, 301st and 401st spot on line one are formed, then the 1st, 101st, 201st, 301st and 401st spot on line 101 are formed, then the 1st, 101st, 201st, 301st and 401st spot on line 201 are formed, and so on such that the minimum spatial distance between temporally successive spots is 100 times the final minimum spot-to-spot spacing. The next pass forms the 2nd, 102nd, 202nd, 302nd and 402nd spot on line one, then the 2nd, 102nd, 202nd, 302nd and 402nd spot on line 101 are formed, and so on, until all 500 by 500 spots that form the desired cut are formed. The present invention, which greatly speeds up the cutting process, makes such a spot-hopping process possible, since much less eye movement is possible with the shorter operation time, on the order of one to two seconds, or less, in some embodiments.

[0056] Figures 4A-6A and 4B-6B represent a LASIK-like procedure.

[0057] Figure 4A is a side cross-section view of an eye 99 after a flap cut 77.

[0058] Figure 4B is a front view of the eye 99 of Figure 4A. Eye 99 includes sclera 92, cornea 98, stroma 97, iris 96, pupil 95, lens 94 and lens muscle 93, and has an optical axis 91. A cut 77 is e.g., parallel to the corneal surface, and is extended to the surface with a cut 76 that extends in a partial arc (e.g., in some embodiments, a 270-degree to 315-degree arc centered on the optical axis) leaving a hinge 74. In some embodiments, a fiducial mark 76 is formed, e.g., as a small subsurface cut on both flap 75 and the surrounding corneal tissue, in order that the flap can be realigned for a better fit when later replaced to its attached configuration.

[0059] Figure 5A is a side cross-section view of an eye 99 after a posterior lenticule cut 78. Figure 5B is a front view of the eye 99 of Figure 5 A. Flap 75 has been folded back. In some embodiments, traditional excimer laser sculpting is performed in the LASIK manner that ablates the surface of the exposed stroma. In other embodiments, a lenticule 70 is formed by an additional FSK cut 78. In some embodiments, cut 78 is formed before cut 77 of Figure 4A (such as described in Figures 7A and 7B but with a flap rather than a slit cut to the surface). In some embodiments, lenticule 70 is mechanically removed (e.g., grabbed with tweezers, or flushed with a saline stream from a small jet).

[0060] Figure 6A is a side cross-section view of an eye 99 after the flap has been resealed. Figure 6B is a front view of the eye 99 of Figure 6A. With lenticule 70 removed, the surface of cornea 98 above the surgery area is altered to correct the visual focus and improve vision.

[0061] Figures 7A-9A, and 7B-9B represent an FLK procedure.

[0062] Figure 7A is a side cross-section view of an eye 99 after two lenticule cuts. Figure 7B is a front view of the eye 99 of Figure 7A. In the embodiment shown, a posterior surface cut 87 is made and an anterior surface cut 88 is made, defining lenticule 80 having a circumference 86, an access slit 89 is made through the surface of the cornea and connecting to lenticule 80.

[0063] Figure 8A is a side cross-section view of an eye 99 as lenticule 80 is removed. Figure 8B is a front view of the eye 99 of Figure 8A. In some embodiments, lenticule 80 is mechanically removed (e.g., grabbed with tweezers 801, or flushed with a saline stream from a small jet).

[0064] Figure 9A is a side cross-section view of an eye 99 after the cornea surface

has been reseated. Figure 9B is a front view of the eye 99 of Figure 9A. With lenticule 80 removed, the surface of cornea 98 above the surgery area is altered to correct the visual focus and improve vision.

[0065] Figure 10 is a side cross-section view of eye interface 1000 with eye 99, showing more details of a typical eye-stabilization and optical interface device 133 of Figure 1 used in some embodiments. The anatomical structure of eye 99, as described above in the description for Figure 1, includes cornea 98 anterior to the pupil 95, the iris 96, and the sclera 92. Optical axis 91 of eye 99 passes through the cornea 98. Cornea 98 includes five tissue layers including the epithelium 981, Bowman's membrane 982, stroma 983, Decemet's membrane 984, and endothelium 985. In some embodiments, suction ring 1016, on the end of support 1014, is placed against sclera 92 and a small vacuum is formed through piping 1015 to chamber 1017 to hold the eye 99 in a fixed location. In some embodiments, actuator 1012 moves disposable contact lens 1010 into contact with the anterior surface of cornea 98. In some embodiments, the index of refraction of contact lens 1010 is made to match the index of refraction of cornea 98, in order that only anterior surface 1011 of lens 1010 changes the direction or focus of beam 129. This allows Computer 135 of Figure 1 to control Scanner 132 in a manner that is more easily calculated, since only the shape of anterior surface 1011 of contact lens 1010 changes the light direction. In some embodiments, the refraction of the eye is checked both before and with contact lens 1010 in place by focusing light on various locations across the entire retina in order to obtain the amount and type of correction needed, and thus to calculate the size and shape of lenticule 80 that will be cut. In some embodiments, scanned laser beam 129 moves the beam 129 such that temporally successive pulses are focused to spaced-apart spot locations (e.g., spatial Spots 1, 2, 3, 4, 5, 6, 7, 8, and 9 on cut 87 at the posterior lenticule surface are more than the minimum final spot-to-spot spacing, as are later formed spatial Spots 11, 12, 13, 14, 15, 16, 17, 18, and 19 on cut 88 at the anterior surface of lenticule 80). In some embodiments, once the cuts are complete (e.g., in one to two seconds or less), contact lens 1010 is withdrawn, and lenticule 80 is mechanically removed through access slit 89. In some embodiments, slit 89 includes an

interlocking configuration, such that unless forced by some threshold amount of force, it will not open, in order to improve the post-operative healing process.

Repetition rate

[0066] Rather than using a low repetition rate laser (e.g., few kHz), the present invention uses a laser system 110 that runs at a repetition rate between about 50 kHz and 1 MHz or greater. In some embodiments, the pulse rate is adjustable by design. In some embodiments, the laser system 110 is combined with a Zeiss optical scanning system 130, and the laser section's pulse-repetition rate is set at 200 kHz. In some embodiments, the power out of laser system 110 is lower than that used in lower-repetition-rate lasers (in some embodiments, the pulse energy leaving laser system 110 is two microJoules), but this is sufficient for the application. The high repetition rate and high scan rate means that the cutting can occur much more rapidly. This is important because the longer the cutting time, the longer the eye must be maintained stationary (or be tracked which is also difficult). For low-repetition-rate lasers to shorten the cutting time, they need to cut larger areas at once (bigger spot size). They can do this because they have higher pulse energy than laser system 110, but it results in a coarser cut, and with more acoustic shock and heat damage that does not heal as well and does not provide as accurate a refractive correction. Therefore system 100 producing many small spots very quickly is a superior method to producing fewer large spots in a similar timeframe.

[0067] Note that the high repetition rate laser system 110 is only useable because optical scanning system 130 (in some embodiments, made by Zeiss) has a very fast scanner that can raster the beam across the eye fast enough to place spots in the desired pattern at 200 kHz.

[0068] Because the laser can be turned on and off rapidly and precisely (using downcounter 115, e.g., under the control of computer 135) and the scanner 132 can be moved rapidly, this enables the user to define unique raster patterns on the eye (such as spaced-apart spots from temporally successive pulses), not achievable with other systems. For example, a pattern in which each successive pulse is focused to a second spot at a distance from a respective previous first spot, and at a later time pulses are focused to other spots between the first and second spot. These patterns

may be used to reduce thermal damage by not cutting in adjacent spots in consecutive exposures, or may enable the creation of unique eye correction patterns by allowing shaping of the cornea in new ways.

Pre-compression

[0069] Femtosecond pulses are distorted (due to dispersion) as they go through optical fibers, lenses, or other elements along an optical path (e.g., in scanning system 130). Therefore, the pulse of light available for cutting at the eye 99 will not be the same as the pulse that comes out of the laser system due to dispersion from the complex optical system between these two points. Since it is desirable, in some embodiments, to have a pulse of about 350 fs at the eye 99, we need to produce a pulse (of stream 127) back at the exit of laser system 110 that, after going through all of the optics, will have this duration at the focal point in the eye. This is achieved by precompression of the pulse at, e.g., the last stage (preconditioning grating compressor 117) of the laser system 99. In other embodiments, the preconditioning is performed earlier, and accommodates later stages within laser system 110. Instead of the normal grating compressor that would be used to produce a 350-fs pulse at the output of the laser, a compressor is used that adds a second-order dispersion to the pulse that exactly compensates for the second-order dispersion of the optical system leading to the eye. In some embodiments using the Zeiss scanning system 130, this precompression is $-2 \times 10^4 \text{ fs}^{-2}$.

[0070] It should also be noted that the optical energy is also dissipated throughout the system, so that while at the laser the pulse energy is 2 μJ , when it reaches the eye, it will be significantly lower (in some embodiments, on the order of 1 μJ or less). This cutting energy is also important to the overall process. Too little energy does not cut because the threshold for LIOB is not achieved, while too much energy can cause thermal damage to adjacent tissue or larger spots.

[0071] Some embodiments of the present invention provide an apparatus that includes a pulsed laser 110 having a pulse repetition rate of more than 50000 pulses per second and a per-pulse length of less than one picosecond, and an optical path including a scanning head operably coupled to receive laser light from the pulsed laser and operable to scan an output light pattern suitable to sculpt tissue for a

surgical procedure using at least 100000 pulses in less than ten seconds. In some embodiments, the pulsed laser 110 includes one or more sections of fiber-optic gain medium.

[0072] In some embodiments, the surgical procedure is a complete surface cut of an ophthalmologic surgical procedure, the cut defining a surface, at least a portion of which is within a corneal stroma.

[0073] In some embodiments, the surgical procedure uses at least 500000 pulses in less than five seconds.

[0074] In some embodiments, the surgical procedure uses at least 500000 pulses in less than four seconds.

[0075] In some embodiments, the surgical procedure uses at least 500000 pulses in less than three seconds.

[0076] In some embodiments, the surgical procedure uses at least 500000 pulses in less than two seconds.

[0077] In some embodiments, the surgical procedure uses at least 500000 pulses in one second or less.

[0078] In some embodiments, the surgical procedure uses at least 500000 pulses in one-half second or less.

[0079] In some embodiments, the surgical procedure uses at least 500000 pulses in one-quarter second or less.

[0080] In some embodiments, the surgical procedure uses at least 400000 pulses in less than five seconds.

[0081] In some embodiments, the surgical procedure uses at least 400000 pulses in less than four seconds.

[0082] In some embodiments, the surgical procedure uses at least 400000 pulses in less than three seconds.

[0083] In some embodiments, the surgical procedure uses at least 400000 pulses in less than two seconds.

[0084] In some embodiments, the surgical procedure uses at least 400000 pulses in less than one second.

[0085] In some embodiments, the surgical procedure uses at least 300000 pulses in less than five seconds.

- [0086] In some embodiments, the surgical procedure uses at least 300000 pulses in less than four seconds.
- [0087] In some embodiments, the surgical procedure uses at least 300000 pulses in less than three seconds.
- [0088] In some embodiments, the surgical procedure uses at least 300000 pulses in less than two seconds.
- [0089] In some embodiments, the surgical procedure uses at least 300000 pulses in less than one second.
- [0090] In some embodiments, the surgical procedure uses at least 200000 pulses in less than five seconds.
- [0091] In some embodiments, the surgical procedure uses at least 200000 pulses in less than four seconds.
- [0092] In some embodiments, the surgical procedure uses at least 200000 pulses in less than three seconds.
- [0093] In some embodiments, the surgical procedure uses at least 200000 pulses in less than two seconds.
- [0094] In some embodiments, the surgical procedure uses at least 200000 pulses in less than one second.
- [0095] In some embodiments, the surgical procedure uses at least 100000 pulses in less than five seconds.
- [0096] In some embodiments, the surgical procedure uses at least 100000 pulses in less than four seconds.
- [0097] In some embodiments, the surgical procedure uses at least 100000 pulses in less than three seconds.
- [0098] In some embodiments, the surgical procedure uses at least 100000 pulses in less than two seconds.
- [0099] In some embodiments, the surgical procedure uses at least 100000 pulses in less than one second.
- [00100] In some embodiments, the surgical procedure uses at least 100000 pulses in one-half second or less.
- [00101] In some embodiments, the surgical procedure uses at least 50000 pulses in less than five seconds.

- [00102] In some embodiments, the surgical procedure uses at least 50000 pulses in less than four seconds.
- [00103] In some embodiments, the surgical procedure uses at least 50000 pulses in less than three seconds.
- [00104] In some embodiments, the surgical procedure uses at least 50000 pulses in less than two seconds.
- [00105] In some embodiments, the surgical procedure uses at least 50000 pulses in less than one second.
- [00106] In some embodiments, the surgical procedure uses at least 50000 pulses in one-half second or less.
- [00107] In some embodiments, the surgical procedure uses at least 25000 pulses in one-quarter second or less.
- [00108] In some embodiments, the surgical procedure uses at least 50000 pulses in one-quarter second or less.
- [00109] In some embodiments, the surgical procedure uses at least 100000 pulses in one-quarter second or less.
- [00110] In some embodiments, the surgical procedure forms a first cut that defines a posterior surface of a lenticule within a corneal stroma, a second cut that defines a lenticule anterior surface of the lenticule, and a slit cut that extends to the cornea surface, wherein the three cuts are completed within five seconds. In some such embodiments, the slit cut either forms or subtends an arc of less than 180 degrees measured from the lenticule's center.
- [00111] In some embodiments, the surgical procedure forms a first cut that defines a posterior surface of a corneal flap that can be folded back to expose a stroma surface to allow a conventional LASIK operation on the exposed stroma surface, wherein the first cut is completed within two seconds.
- [00112] Some embodiments further include a precompressor that creates a negative dispersion in each pulse that compensates for a dispersion of the optical path after the precompressor.
- [00113] In some embodiments, the scanning head focuses at least 100000 pulses per second and the per-pulse length is less than 999 femtoseconds.
- [00114] In some embodiments, the scanning head focuses at least 100000 pulses

per second and the per-pulse length is less than 750 femtoseconds.

[00115] In some embodiments, the scanning head focuses at least 100000 pulses per second and the per-pulse length is less than 500 femtoseconds.

[00116] In some embodiments, the scanning head focuses at least 100000 pulses per second and the per-pulse length is less than 400 femtoseconds.

[00117] In some embodiments, the scanning head focuses at least 100000 pulses per second and the per-pulse length is 350 femtoseconds or less.

[00118] In some embodiments, the scanning head focuses at least 200000 pulses per second and the per-pulse length is less than 999 femtoseconds.

[00119] In some embodiments, the scanning head focuses at least 200000 pulses per second and the per-pulse length is less than 750 femtoseconds.

[00120] In some embodiments, the scanning head focuses at least 200000 pulses per second and the per-pulse length is less than 500 femtoseconds.

[00121] In some embodiments, the scanning head focuses at least 200000 pulses per second and the per-pulse length is less than 400 femtoseconds.

[00122] In some embodiments, the scanning head focuses at least 200000 pulses per second and the per-pulse length is 350 femtoseconds or less.

[00123] In some embodiments, the scanning head focuses at 200000 pulses per second and the per-pulse length is 350 femtoseconds.

[00124] In some embodiments, the scanning head focuses at 200000 pulses per second and the per-pulse length is about 500 femtoseconds.

[00125] In some embodiments, the scanning head focuses at 200000 pulses per second and the per-pulse length is about 450 femtoseconds.

[00126] In some embodiments, the scanning head focuses at 200000 pulses per second and the per-pulse length is about 400 femtoseconds.

[00127] In some embodiments, the scanning head focuses at 200000 pulses per second and the per-pulse length is about 350 femtoseconds.

[00128] In some embodiments, the scanning head focuses at 200000 pulses per second and the per-pulse length is about 300 femtoseconds.

[00129] In some embodiments, the scanning head focuses at 200000 pulses per second and the per-pulse length is about 250 femtoseconds.

[00130] In some embodiments, the scanning head focuses at 200000 pulses per

second and the per-pulse length is about 200 femtoseconds.

[00131] In some embodiments, the scanning head focuses at 200000 pulses per second and the per-pulse length is about 150 femtoseconds.

[00132] In some embodiments, the scanning head focuses -at 200000 pulses per second and the per-pulse length is about 100 femtoseconds.

[00133] In some embodiments, the scanning head focuses at 200000 pulses per second and the per-pulse length is about 50 femtoseconds.

[00134] In some embodiments, the scanning head focuses at least 500000 pulses per second and the per-pulse length is less than 999 femtoseconds.

[00135] In some embodiments, the scanning head focuses at least 500000 pulses per second and the per-pulse length is less than 750 femtoseconds.

[00136] In some embodiments, the scanning head focuses at least 500000 pulses per second and the per-pulse length is less than 500 femtoseconds.

[00137] In some embodiments, the scanning head focuses at least 500000 pulses per second and the per-pulse length is less than 400 femtoseconds.

[00138] In some embodiments, the scanning head focuses at least 500000 pulses per second and the per-pulse length is 350 femtoseconds or less.

[00139] In some embodiments, the scanning head focuses at least 1000000 pulses per second and the per-pulse length is less than 999 femtoseconds.

[00140] In some embodiments, the scanning head focuses at least 1000000 pulses per second and the per-pulse length is less than 750 femtoseconds.

[00141] In some embodiments, the scanning head focuses at least 1000000 pulses per second and the per-pulse length is less than 500 femtoseconds.

[00142] In some embodiments, the scanning head focuses at least 1000000 pulses per second and the per-pulse length is less than 400 femtoseconds.

[00143] In some embodiments, the scanning head focuses at least 1000000 pulses per second and the per-pulse length is 350 femtoseconds or less.

[00144] Other embodiments of the invention include a method that includes generating a stream of pulses having a pulse repetition rate of at least about 50000 pulses per second and a per-pulse length of less than one picosecond, and scanning and focusing the stream to an output light pattern suitable to sculpt tissue for a surgical procedure using at least 100000 pulses in less than ten seconds. In some

embodiments, the stream of pulses is generated by a pulsed laser that includes one or more sections of fiber-optic gain medium.

[00145] In some embodiments of the method, the surgical procedure is a complete surface cut of an ophthalmologic surgical procedure, the cut defining a surface, at least a portion of which is within a corneal stroma.

[00146] In some embodiments of the method, the scanning and focusing uses at least 200000 pulses to form at least one cut that is completed in less than five seconds.

[00147] In some embodiments of the method, the scanning and focusing uses at least 200000 pulses to form at least one cut that is completed in less than two seconds.

[00148] In some embodiments of the method, the scanning and focusing forms a first cut that defines a posterior surface of a lenticule within a corneal stroma, a second cut that defines an lenticule anterior surface of the lenticule, and a slit cut that extends to the cornea surface, wherein the three cuts are completed within five seconds. In some such embodiments, the slit cut either forms or subtends an arc of less than 180 degrees measured from the lenticule's center.

[00149] In some embodiments of the method, the surgical procedure forms a first cut that defines a posterior surface of a corneal flap that can be folded back to expose a stroma surface to allow a LASIK Operation on the exposed stroma surface, wherein the first cut is completed within two seconds.

[00150] Some embodiments of the method further include precompressing each pulse to create a negative dispersion that compensates for a dispersion of an optical path after the precompressor.

[00151] In some embodiments of the method, the scanning and focusing focuses at least 100000 pulses per second and the per-pulse length is less than 500 femtoseconds.

[00152] In some embodiments of the method, the scanning and focusing focuses at least about 200000 pulses per second and the per-pulse length is less than 400 femtoseconds.

[00153] In some embodiments of the method, the scanning and focusing focuses at 200000 pulses per second and the per-pulse length is 350 femtoseconds.

[00154] It is understood that the above description is intended to be illustrative, and not restrictive. Many other embodiments will be apparent to those of skill in the art upon reviewing the above description. The scope of the invention should, therefore be determined with reference to the appended claims, along with the full scope of equivalents to which such claims are entitled. In the appended claims, the terms "including" and "in which" are used as the plain-English equivalents of the respective terms "comprising" and "wherein," respectively. Moreover, the terms "first," "second," and "third," etc., are used merely as labels, and are not intended to impose numerical requirements on their objects.

What is claimed is:

1. An apparatus comprising:
 - a pulsed laser that includes a fiber optical gain medium and having a pulse repetition rate of more than 50000 pulses per second and a per-pulse length of less than one picosecond; and
 - an optical path including a scanning head operably coupled to receive laser light from the pulsed laser and operable to scan an output light pattern suitable to sculpt tissue for a surgical procedure using at least 100000 pulses in less than ten seconds.
2. The apparatus of claim 1, wherein the surgical procedure is a complete surface cut of an ophthalmologic surgical procedure, the cut defining a surface, at least a portion of which is within a corneal stroma.
3. The apparatus of claim 1, wherein the surgical procedure uses at least 200000 pulses in less than five seconds.
4. The apparatus of claim 1, wherein the surgical procedure uses at least 200000 pulses in less than two seconds.
5. The apparatus of claim 1, wherein the surgical procedure forms a first cut that defines a posterior surface of a lenticule within a corneal stroma, a second cut that defines a lenticule anterior surface of the lenticule, and a slit cut that extends to the cornea surface, wherein the three cuts are completed within five seconds.
6. The apparatus of claim 5, wherein the slit cut either forms or subtends an arc of less than 180 degrees measured from the lenticule's center.
7. The apparatus of claim 1, wherein the surgical procedure forms a first cut that defines a posterior surface of a corneal flap that can be folded back to expose a

stroma surface to allow a conventional LASIK Operation on the exposed stroma surface, wherein the first cut is completed within two seconds.

8. The apparatus of claim 1, further comprising a precompressor that creates a negative dispersion in each pulse that compensates for a dispersion of the optical path after the precompressor.
9. The apparatus of claim 1, wherein the scanning head focuses at least 100000 pulses per second and the per-pulse length is less than 500 femtoseconds.
10. The apparatus of claim 1, wherein the scanning head focuses at least about 200000 pulses per second and the per-pulse length is less than 400 femtoseconds.
11. A method comprising:
 - generating a stream of pulses having a pulse repetition rate of at least about 50000 pulses per second and a per-pulse length of less than one picosecond using an optical fiber gain medium; and
 - scanning and focusing the stream to an Output light pattern suitable to sculpt tissue for a surgical procedure using at least 100000 pulses in less than ten seconds.
12. The method of claim 11, wherein the surgical procedure is a complete surface cut of an ophthalmologic surgical procedure, the cut defining a surface, at least a portion of which is within a corneal stroma.
13. The method of claim 11, wherein the scanning and focusing uses at least 200000 pulses to form at least one cut that is completed in less than five seconds.
14. The method of claim 11, wherein the scanning and focusing uses at least 200000 pulses to form at least one cut that is completed in less than two seconds.

15. The method of claim 11, wherein the scanning and focusing forms a first cut that defines a posterior surface of a lenticule within a corneal stroma, a second cut that defines an lenticule anterior surface of the lenticule, and a slit cut that extends to the cornea surface, wherein the three cuts are completed within five seconds.
16. The method of claim 15, wherein the slit cut either forms or subtends an arc of less than 180 degrees measured from the lenticule's center.
17. The method of claim 11, wherein the surgical procedure forms a first cut that defines a posterior surface of a corneal flap that can be folded back to expose a stroma surface to allow a LASIK operation on the exposed stroma surface, wherein the first cut is completed within two seconds.
18. The method of claim 11, further comprising precompressing each pulse to create a negative dispersion that compensates for a dispersion of an optical path after the precompressor.
19. The method of claim 11, wherein the scanning and focusing focuses at least 100000 pulses per second and the per-pulse length is less than 500 femtoseconds.
20. The method of claim 11, wherein the scanning and focusing focuses at least about 200000 pulses per second and the per-pulse length is less than 400 femtoseconds.
21. An apparatus comprising:
optical fiber means for generating a stream of pulses having a pulse repetition rate of at least about 50000 pulses per second and a per-pulse length of less than one picosecond; and
means for scanning and focusing the stream to an Output light pattern suitable to sculpt tissue for a surgical procedure using at least 100000 pulses in less than ten seconds.

22. The apparatus of claim 21, wherein the means for scanning and focusing is operable to form a complete cut for an ophthalmologic surgical procedure, the cut defining a surface, at least a portion of which is within a corneal stroma.
23. The apparatus of claim 21, wherein the scanning and focusing uses at least 200000 pulses to form at least one cut that is completed in less than five seconds.
24. The apparatus of claim 21, wherein the scanning and focusing uses at least 200000 pulses to form at least one cut that is completed in less than two seconds.
25. The apparatus of claim 21, wherein the means for scanning and focusing is operable to form a first cut that defines a posterior surface of a lenticule within a corneal stroma, a second cut that defines an lenticule anterior surface of the lenticule, and a slit cut that extends to the cornea surface, wherein the three cuts are completed within five seconds.
26. The apparatus of claim 25, wherein the slit cut either forms or subtends an arc of less than 180 degrees measured from the lenticule's center.
27. The apparatus of claim 21, wherein the surgical procedure forms a first cut that defines a posterior surface of a corneal flap that can be folded back to expose a stroma surface to allow a LASIK operation on the exposed stroma surface, wherein the first cut is completed within two seconds.
28. The apparatus of claim 21, further comprising means for precompressing each pulse to create a negative dispersion that compensates for a dispersion of an optical path after the precompressor.
29. The apparatus of claim 21, wherein the means for scanning and focusing focuses at least 100000 pulses per second and the per-pulse length is less than 500 femtoseconds.

30. The apparatus of claim 21, wherein the means for scanning and focusing focuses at least about 200000 pulses per second and the per-pulse length is less than 400 femtoseconds.

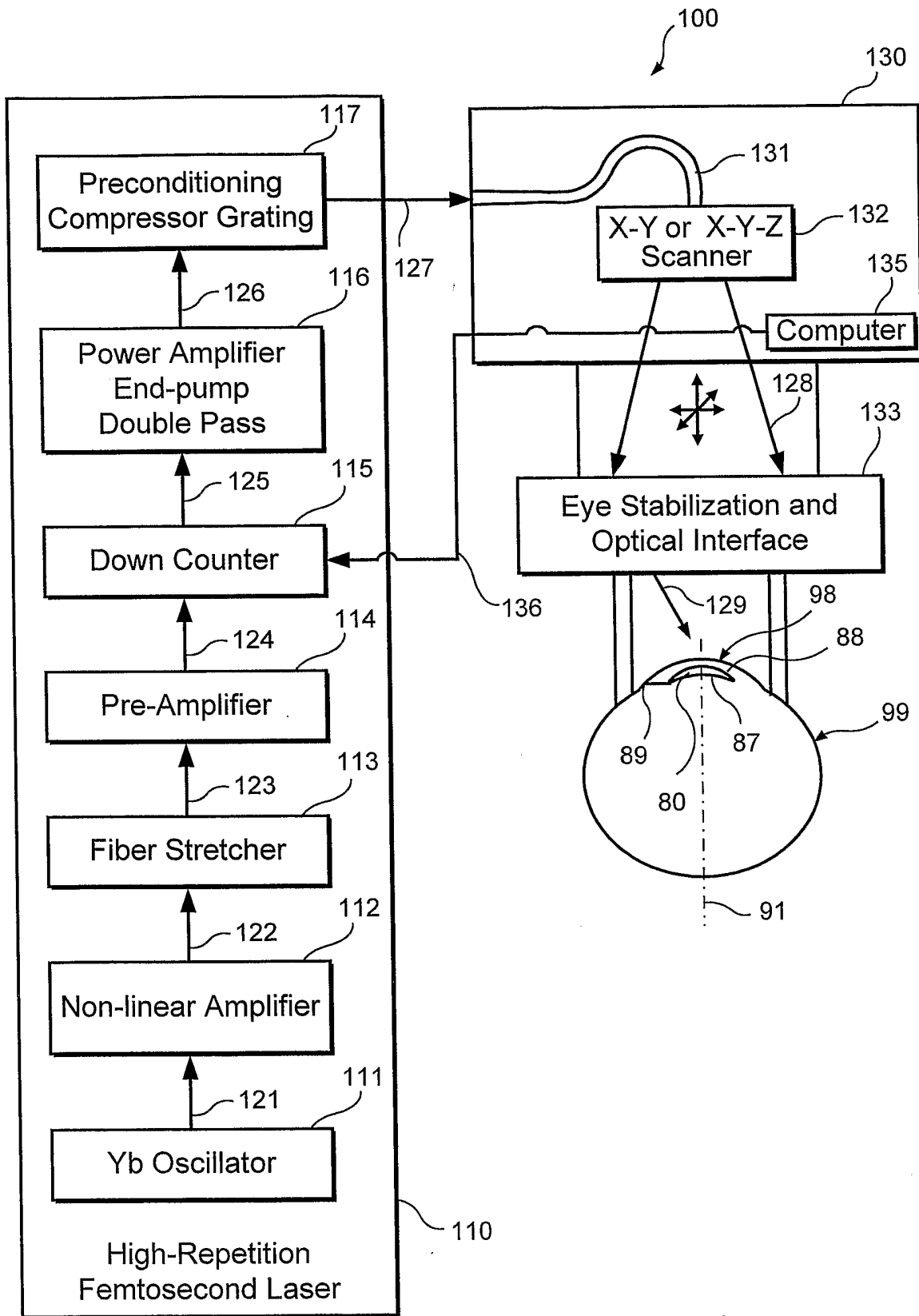

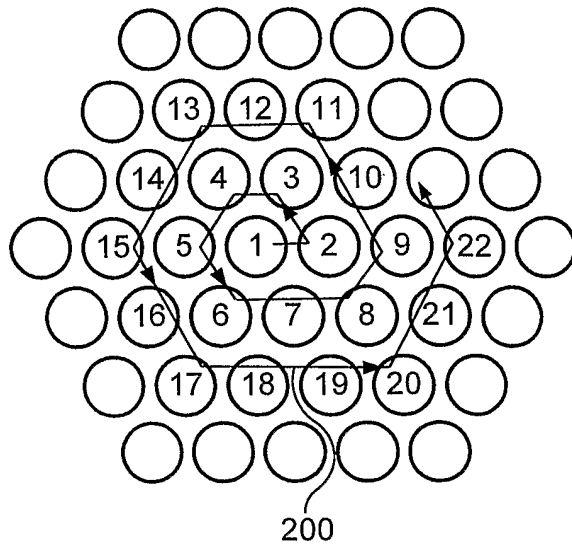

FIG. 2

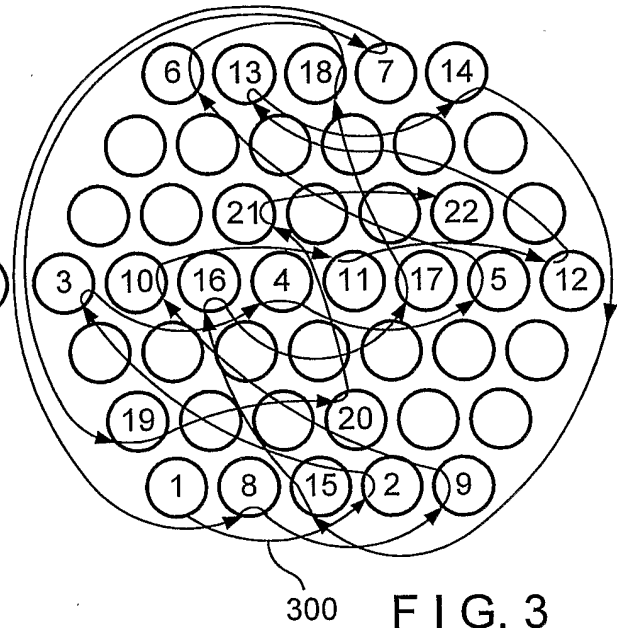

FIG. 3

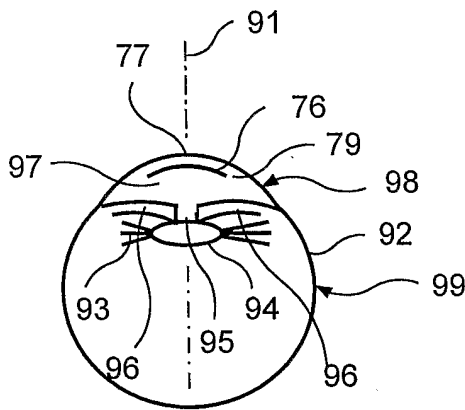

FIG. 4A

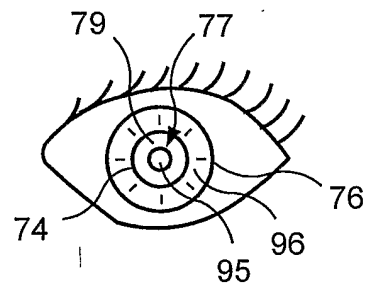

FIG. 4B

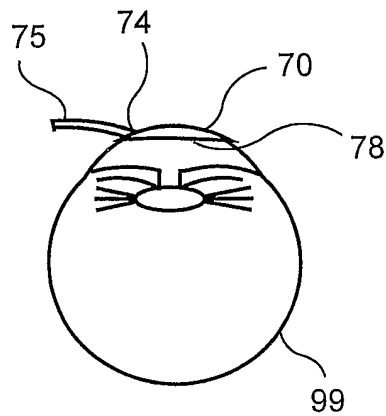

FIG. 5A

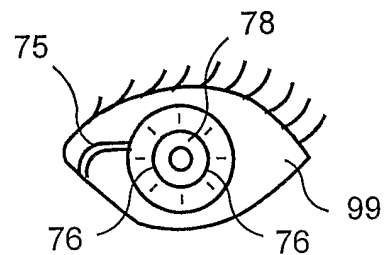

FIG. 5B



FIG. 6A

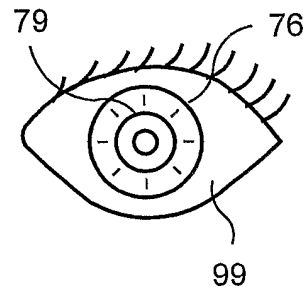

FIG. 6B

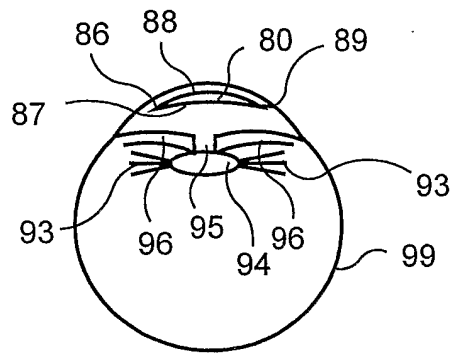

FIG. 7A

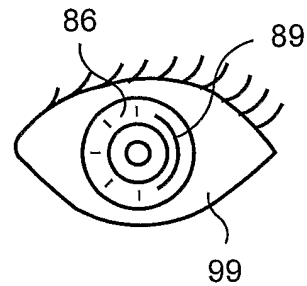

FIG. 7B

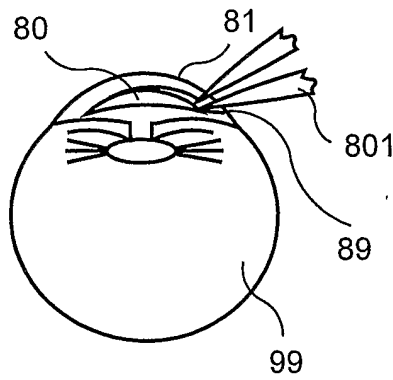

FIG. 8A

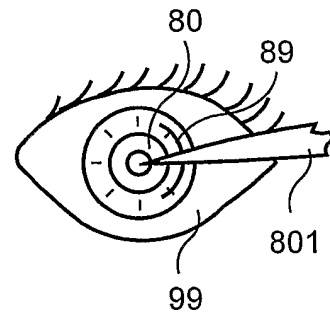

FIG. 8B

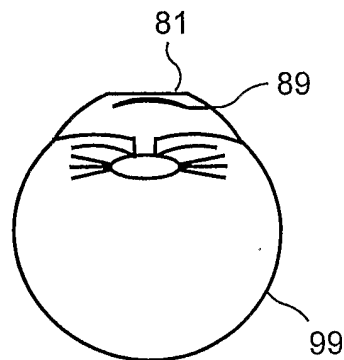

FIG. 9A

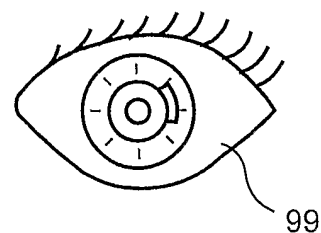

FIG. 9B

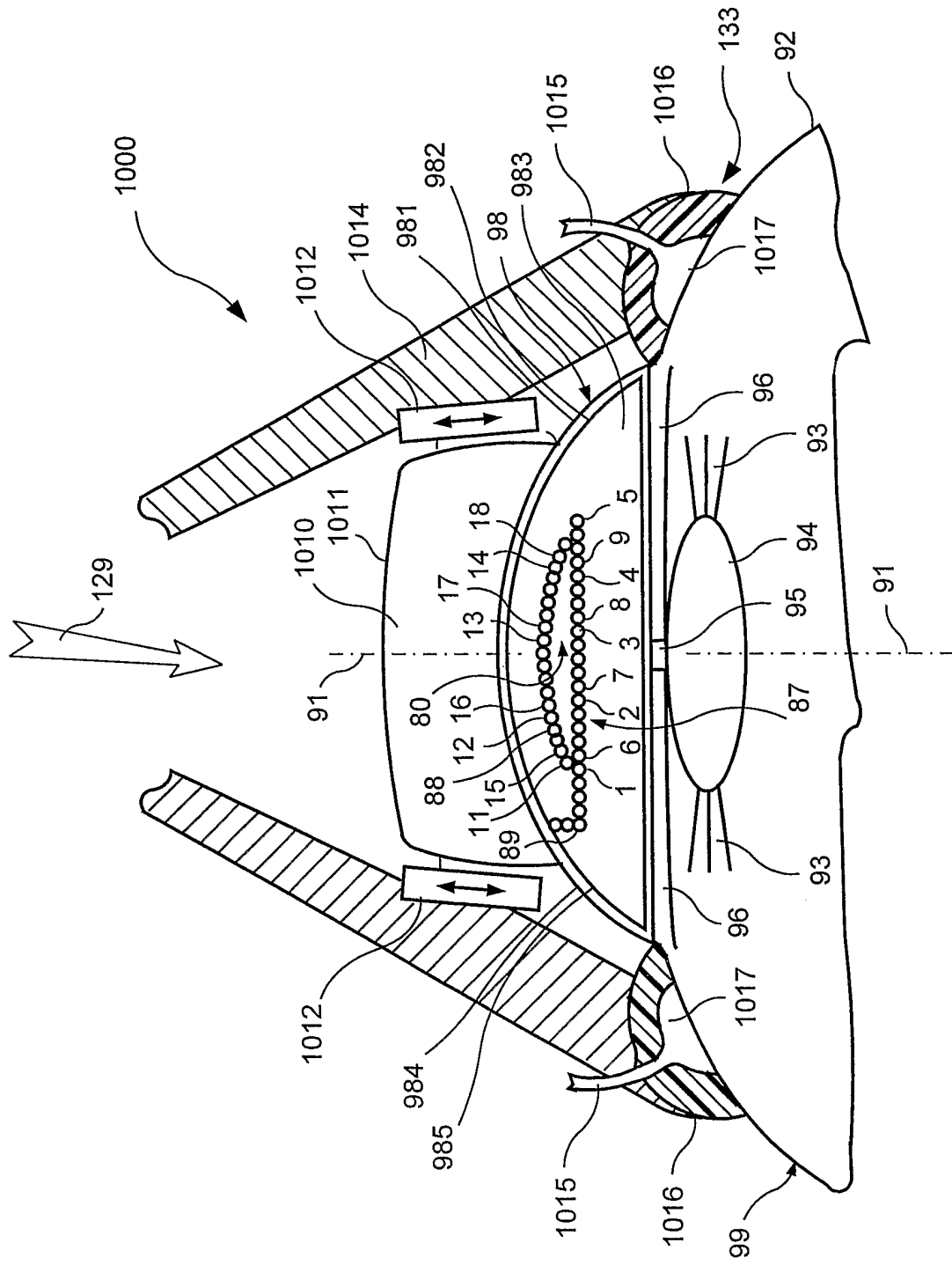

FIG. 10

INTERNATIONAL SEARCH REPORT

tional Application No
/IB2004/001781

A. CLASSIFICATION OF SUBJECT MATTER
IPC 7 A61F9/007 A61F9/008 H01S3/067 H01S3/094

According to International Patent Classification (IPC) or to both national classification and IPC

B. FIELDS SEARCHED

Minimum documentation searched (classification system followed by classification symbols)
IPC 7 A61F H01S

Documentation searched other than minimum documentation to the extent that such documents are included in the fields searched

Electronic data base consulted during the international search (name of data base and, where practical, search terms used)

EPO-Internal

C. DOCUMENTS CONSIDERED TO BE RELEVANT

Category °	Citation of document, with indication, where appropriate, of the relevant passages	Relevant to claim No.
Y	US 6 090 102 A (TELFAIR WILLIAM B ET AL) 18 July 2000 (2000-07-18)	1-4, 9, 10, 21-24, 29, 30
A	column 2, line 40 - column 12, line 41	5-8, 25-28
Y	US 2002/168161 A1 (PRICE JONATHAN HUGH VAUGHAN ET AL) 14 November 2002 (2002-11-14)	1-4, 9, 10, 21-24, 29, 30
A	paragraphs '0010! - '0012! paragraphs '0061! - '0087!	
A	WO 95/04509 A (GWON ARLENE E) 16 February 1995 (1995-02-16) page 12, line 25 - page 13, line 27	1, 21
	-/--	

Further documents are listed in the continuation of box C.

Patent family members are listed in annex.

° Special categories of cited documents:

- *A* document defining the general state of the art which is not considered to be of particular relevance
- *E* earlier document but published on or after the international filing date
- *L* document which may throw doubts on priority claim(s) or which is cited to establish the publication date of another citation or other special reason (as specified)
- *O* document referring to an oral disclosure, use, exhibition or other means
- *P* document published prior to the international filing date but later than the priority date claimed

- *T* later document published after the international filing date or priority date and not in conflict with the application but cited to understand the principle or theory underlying the invention
- *X* document of particular relevance; the claimed invention cannot be considered novel or cannot be considered to involve an inventive step when the document is taken alone
- *Y* document of particular relevance; the claimed invention cannot be considered to involve an inventive step when the document is combined with one or more other such documents, such combination being obvious to a person skilled in the art.
- *Z* document member of the same patent family

Date of the actual completion of the international search

24 August 2004

Date of mailing of the international search report

31/08/2004

Name and mailing address of the ISA

European Patent Office, P.B. 5818 Patentlaan 2
NL - 2280 HV Rijswijk
Tel. (+31-70) 340-2040, Tx. 31 651 epo nl,
Fax: (+31-70) 340-3016

Authorized officer

Rivera Pons, C

INTERNATIONAL SEARCH REPORT

onal Application No
IB2004/001781

C.(Continuation) DOCUMENTS CONSIDERED TO BE RELEVANT		
Category °	Citation of document, with indication, where appropriate, of the relevant passages	Relevant to claim No.
A	US 4 309 998 A (ARON ROSA DANIELE S ET AL) 12 January 1982 (1982-01-12) column 3, line 53 - column 4, line 27 -----	1,21

INTERNATIONAL SEARCH REPORT

International application No.
PCT/IB2004/001781

Box II Observations where certain claims were found unsearchable (Continuation of item 2 of first sheet)

This International Search Report has not been established in respect of certain claims under Article 17(2)(a) for the following reasons:

1. Claims Nos.: 11-20
because they relate to subject matter not required to be searched by this Authority, namely:
Rule 39.1(iv) PCT - Method for treatment of the human or animal body by surgery
2. Claims Nos.:
because they relate to parts of the International Application that do not comply with the prescribed requirements to such an extent that no meaningful International Search can be carried out, specifically:
3. Claims Nos.:
because they are dependent claims and are not drafted in accordance with the second and third sentences of Rule 6.4(a).

Box III Observations where unity of invention is lacking (Continuation of item 3 of first sheet)

This International Searching Authority found multiple inventions in this international application, as follows:

1. As all required additional search fees were timely paid by the applicant, this International Search Report covers all searchable claims.
2. As all searchable claims could be searched without effort justifying an additional fee, this Authority did not invite payment of any additional fee.
3. As only some of the required additional search fees were timely paid by the applicant, this International Search Report covers only those claims for which fees were paid, specifically claims Nos.:
4. No required additional search fees were timely paid by the applicant. Consequently, this International Search Report is restricted to the invention first mentioned in the claims; it is covered by claims Nos.:

Remark on Protest

- The additional search fees were accompanied by the applicant's protest.
- No protest accompanied the payment of additional search fees.

INTERNATIONAL SEARCH REPORT

Information on patent family members

International Application No
PCT/IB2004/001781

Patent document cited in search report	Publication date	Patent family member(s)	Publication date
US 6090102	A	18-07-2000	AU 5930298 A 08-12-1998
			CA 2288139 A1 19-11-1998
			EP 0981312 A1 01-03-2000
			WO 9851245 A1 19-11-1998
US 2002168161	A1	14-11-2002	CA 2443504 A1 24-10-2002
			EP 1378034 A2 07-01-2004
			WO 02084821 A2 24-10-2002
WO 9504509	A	16-02-1995	US 6322556 B1 27-11-2001
			WO 9504509 A1 16-02-1995
			US 2002103478 A1 01-08-2002
US 4309998	A	12-01-1982	FR 2442622 A1 27-06-1980
			AT 15855 T 15-10-1985
			BR 7903628 A 05-02-1980
			DE 2967522 D1 07-11-1985
			EP 0007256 A1 23-01-1980
			ES 8100873 A1 01-03-1981
			IN 152302 A1 17-12-1983
			JP 55002484 A 09-01-1980
			SU 1019993 A3 23-05-1983