



- (51) International Patent Classification:  
*F03D 3/06* (2006.01)
- (21) International Application Number:  
PCT/US2012/000020
- (22) International Filing Date:  
10 January 2012 (10.01.2012)
- (25) Filing Language: English
- (26) Publication Language: English
- (30) Priority Data:  
13/134,049 27 May 2011 (27.05.2011) US
- (72) Inventor; and  
(71) Applicant : SAUER, Dieter [US/US].
- (74) Agent: Law Offices of Roland Tong, PC; 24373 El Molina Avenue, Valencia, CA 91355 (US).
- (81) Designated States (unless otherwise indicated, for every kind of national protection available): AE, AG, AL, AM,

AO, AT, AU, AZ, BA, BB, BG, BH, BR, BW, BY, BZ, CA, CH, CL, CN, CO, CR, CU, CZ, DE, DK, DM, DO, DZ, EC, EE, EG, ES, FI, GB, GD, GE, GH, GM, GT, HN, HR, HU, ID, IL, IN, IS, JP, KE, KG, KM, KN, KP, KR, KZ, LA, LC, LK, LR, LS, LT, LU, LY, MA, MD, ME, MG, MK, MN, MW, MX, MY, MZ, NA, NG, NI, NO, NZ, OM, PE, PG, PH, PL, PT, QA, RO, RS, RU, RW, SC, SD, SE, SG, SK, SL, SM, ST, SV, SY, TH, TJ, TM, TN, TR, TT, TZ, UA, UG, US, UZ, VC, VN, ZA, ZM, ZW.

- (84) Designated States (unless otherwise indicated, for every kind of regional protection available): ARIPO (BW, GH, GM, KE, LR, LS, MW, MZ, NA, RW, SD, SL, SZ, TZ, UG, ZM, ZW), Eurasian (AM, AZ, BY, KG, KZ, MD, RU, TJ, TM), European (AL, AT, BE, BG, CH, CY, CZ, DE, DK, EE, ES, FI, FR, GB, GR, HR, HU, IE, IS, IT, LT, LU, LV, MC, MK, MT, NL, NO, PL, PT, RO, RS, SE, SI, SK, SM, TR), OAPI (BF, BJ, CF, CG, CI, CM, GA, GN, GQ, GW, ML, MR, NE, SN, TD, TG).

[Continued on next page]

- (54) Title: WIND SAIL TURBINE

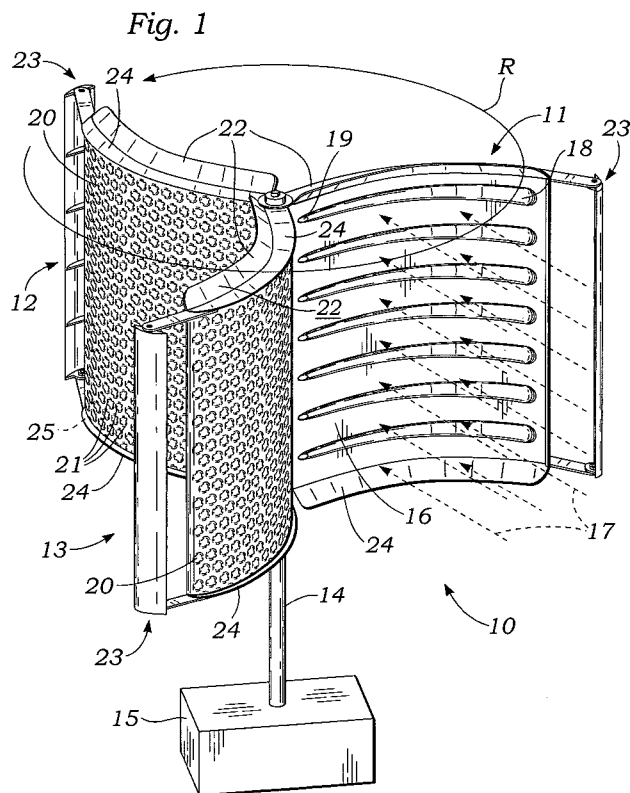

(57) Abstract: A vertical axis omni-wind turbine having a wind sail centrally mounted to a turbine drive shaft, the wind sail consisting of three generally identical vanes, or blades, separated 120 degrees apart. The blades each have a generally concave surface with an opposite or reverse surface that is generally convex. As designed and mounted to the turbine drive shaft, the wind sail provides a self starting air foil in that each blade includes one side having a generally concave configuration to capture impinging wind thrust with the other side having a generally convex configuration to provide minimal wind resistance. The resulting disparate wind resistance causes a stronger reaction on the concave side of a vane which in turn provides rotation about the vertical oriented drive shaft.

WO 2012/166209 A3



**Published:**

**(88) Date of publication of the international search report:**

- *with international search report (Art. 21(3))*
- *before the expiration of the time limit for amending the claims and to be republished in the event of receipt of amendments (Rule 48.2(h))*

16 May 2013

**INTERNATIONAL SEARCH REPORT**

International application No.  
PCT/US2012/000020

**A. CLASSIFICATION OF SUBJECT MATTER**

IPC(8) - F03D 3/06 (2012.01)

USPC - 415/4.2

According to International Patent Classification (IPC) or to both national classification and IPC

**B. FIELDS SEARCHED**

Minimum documentation searched (classification system followed by classification symbols)

IPC(8) - F03D3/04, 3/06(2012.01)

USPC - 415/4.2

Documentation searched other than minimum documentation to the extent that such documents are included in the fields searched  
ECLA - Y02E 10/74 (2012.01)

Electronic data base consulted during the international search (name of data base and, where practicable, search terms used)

PatBase, Google Patents

**C. DOCUMENTS CONSIDERED TO BE RELEVANT**

Category*	Citation of document, with indication, where appropriate, of the relevant passages	Relevant to claim No.
X - Y	US 2011/0008167 A1 (CUMMINGS) 13 January 2011 (13.01.2011) entire document	1, 2 ----- 3-14
Y	US 2009/0003999 A1 (WHITWORTH et al) 01 January 2009 (01.01.2009) entire document	3, 4, 8-10, 12-14
Y	US 7,604,461 B2 (BONNET) 20 October 2009 (20.10.2009) entire document	5, 7-14
Y	US 4,430,044 A (LILJEGREN) 07 February 1984 (07.02.1984) entire document	6, 14
A	US 4,362,470 A (LOCASTRO et al) 07 December 1982 (07.12.1982) entire document	1-14

Further documents are listed in the continuation of Box C.

* Special categories of cited documents:	"T" later document published after the international filing date or priority date and not in conflict with the application but cited to understand the principle or theory underlying the invention
"A" document defining the general state of the art which is not considered to be of particular relevance	"X" document of particular relevance; the claimed invention cannot be considered novel or cannot be considered to involve an inventive step when the document is taken alone
"E" earlier application or patent but published on or after the international filing date	"Y" document of particular relevance; the claimed invention cannot be considered to involve an inventive step when the document is combined with one or more other such documents, such combination being obvious to a person skilled in the art
"L" document which may throw doubts on priority claim(s) or which is cited to establish the publication date of another citation or other special reason (as specified)	"&" document member of the same patent family
"O" document referring to an oral disclosure, use, exhibition or other means	
"P" document published prior to the international filing date but later than the priority date claimed	

Date of the actual completion of the international search  
16 April 2012

Date of mailing of the international search report  
**22 MAR 2013**

Name and mailing address of the ISA/US  
Mail Stop PCT, Attn: ISA/US, Commissioner for Patents  
P.O. Box 1450, Alexandria, Virginia 22313-1450  
Facsimile No. 571-273-3201

Authorized officer:  
Blaine R. Copenheaver

PCT Helpdesk: 571-272-4300  
PCT OSP: 571-272-7774