

T. LAMB.

Sewing Machine.

No. 101,137.

Patented Mar. 22, 1870.

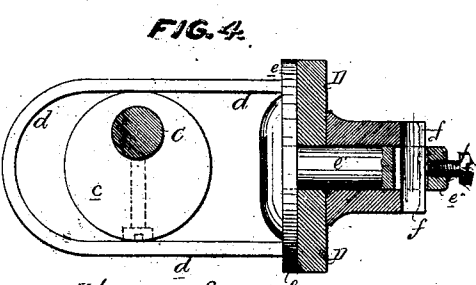
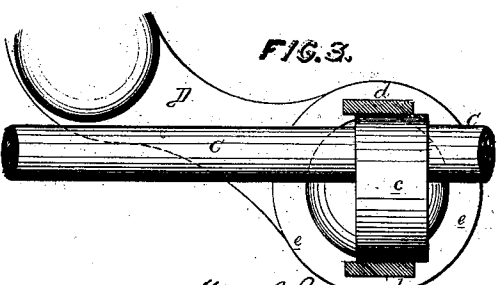
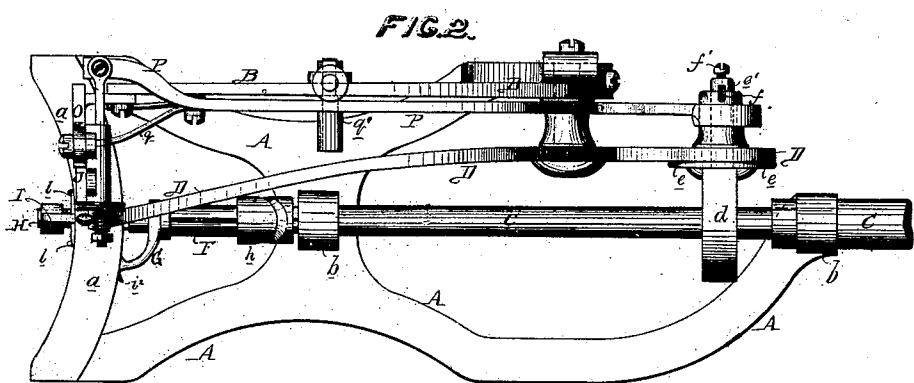
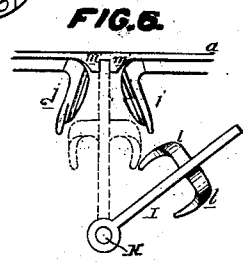
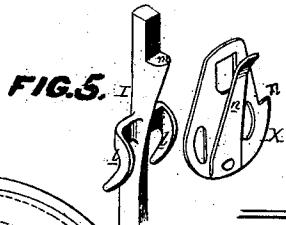
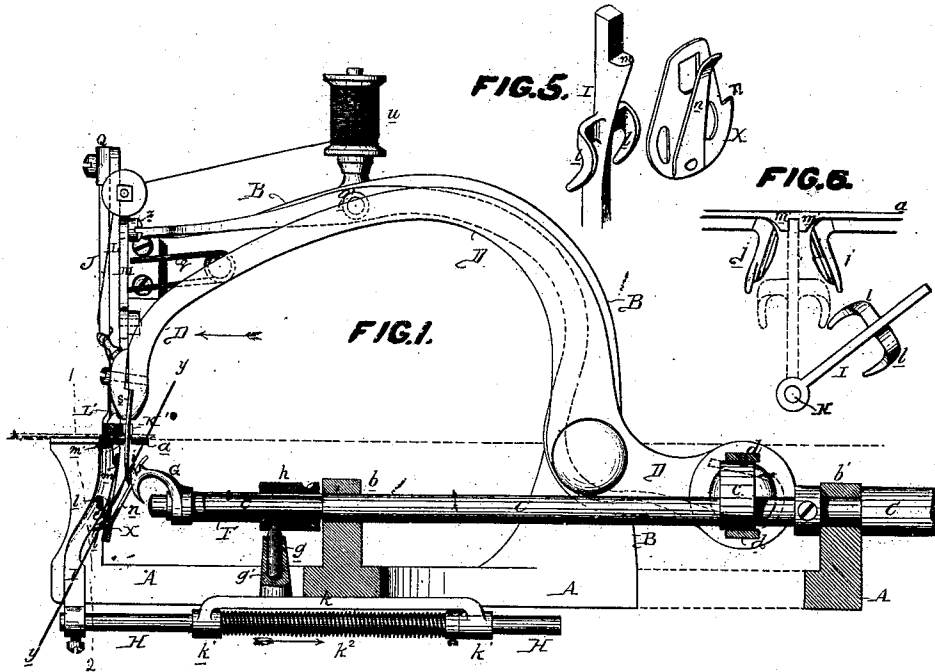

WITNESSES  
*Wm. A. Steel.*  
*John Parker*

*Thomas Lamb*  
 by his atty  
*Howson and*

T. LAMB.  
Sewing Machine.

No. 101,137.

Patented Mar. 22, 1870.

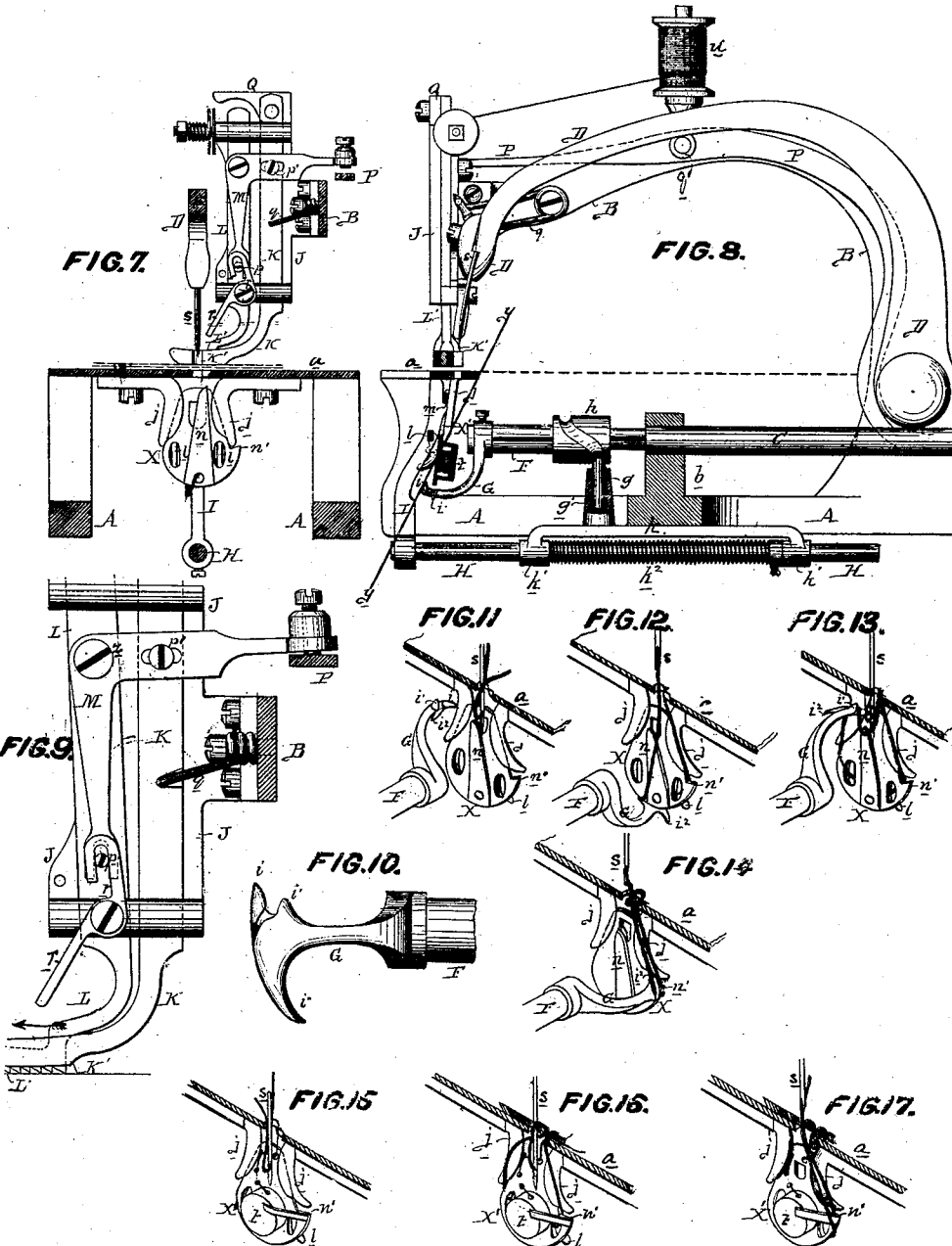

WITNESSES { *Wm. A. Steel.*  
*John Parker*

*Thomas Lamb*  
*by his Attor.*  
*Howson and son*

# UNITED STATES PATENT OFFICE.

THOMAS LAMB, OF PHILADELPHIA, PENNSYLVANIA.

## IMPROVEMENT IN SEWING-MACHINES.

Specification forming part of Letters Patent No. 101,137, dated March 22, 1870.

*To all whom it may concern:*

Be it known that I, THOMAS LAMB, of Philadelphia, county of Philadelphia, State of Pennsylvania, have invented certain Improvements in Sewing-Machines, of which the following is a specification.

My invention consists of a sewing-machine so constructed that by the employment of certain plates, which can be detached and replaced with the greatest facility and without requiring any tedious or delicate adjustment of the parts, the machine can be arranged for forming either the ordinary chain-stitch or double-threaded lock-stitch.

My invention also consists of certain improvements, fully described hereinafter, in the construction of the various parts of the machine.

In the accompanying drawings, Figure 1, Sheet 1, is a vertical section of my improved sewing-machine; Fig. 2, a plan view of the same; Figs. 3 and 4, enlarged views of part of the driving mechanism; Fig. 5, a detached perspective view; Fig. 6, a front view of the lower portion of the machine; Fig. 7, Sheet 2, a transverse section on the line 1 2, Fig. 1, looking in the direction of the arrow; Fig. 8, a vertical section of the machine as it appears when arranged for making the lock-stitch; Fig. 9, an enlarged view of the presser-foot and feeding mechanism, and of the devices for operating the same; Fig. 10, an enlarged view of the loop-catcher; Figs. 11, 12, 13, and 14, perspective views, showing the method of forming the chain-stitch in the machine; and Figs. 15, 16, and 17, views illustrating the formation of the lock-stitch.

The bed-plate A of the machine consists in the present instance of a mere open frame, to which are secured the usual fixed arm B, the work-plate *a*, and projections or bearings *b b* for the horizontal driving-shaft *c*. The needle-arm D is hung to the fixed arm B, and has the required vibrating movement imparted to it by means of an eccentric, *e*, on the driving-shaft, the eccentric being embraced by a strap, *d*, secured to a disk, *e*, which is pivoted to the needle-arm by a pin, *e'*, extending through the latter, as shown in Fig. 4. The disk is held against the needle-arm, but so that it may turn freely, by means of a key, *f*, which passes through a slot in the pin *e'*, and against which bears a set-screw, *f'*. The object of this ar-

angement is to permit the strap *d* to turn and adjust itself to the eccentric as the needle-arm is vibrated, so as to reduce the friction and binding upon the eccentric which would otherwise occur.

On the front end of the driving-shaft *c* is a sleeve, F, which can slide freely upon but is prevented from turning independently of the said shaft by means of a feather on the latter, which enters a slot in the sleeve.

A pin *g*, which fits snugly but is capable of turning freely in a stationary projection, *g'*, of the bed-plate, enters the groove of a scroll-cam, *h*, which is secured to the rear end of the sleeve F, so that as the driving-shaft and sleeve are turned the latter will also have a longitudinal reciprocating motion imparted to it.

To the front end of the sleeve F is secured a loop-catcher, G, of the peculiar curved form best observed in Figs. 1 and 10, the outer end of this loop-catcher being formed into hooks *i*, *i'*, and *i''*, which will be more particularly referred to hereinafter.

To the under side of the work-plate *a* are secured two curved and rounded arms, *j j*, which may be vertical, but in the present instance are slightly inclined, as best observed in Fig. 8, so that as the loop-catcher is turned, and at the same time moved longitudinally, it may pass behind and beneath the said arms, but always remain in close proximity to the same, from which it will be evident that the angle of these arms must be regulated by the extent of longitudinal movement of the loop-catcher.

To the under side of the bed-plate is permanently secured a bar or plate, *k*, having at each end a tubular projection, *k'*, through which slides a cylindrical rod, H, the latter being acted on by a spiral spring, *k''*, which tends to force it in the direction of the arrow, Fig. 1. To the front end of this spring-rod is secured an arm, I, (having on its opposite sides wings *l l*), which can be adjusted to a position midway between the arms *j j*, as indicated by dotted lines in Fig. 6, or turned laterally in either direction, as shown by full lines. The arms *j j* are recessed slightly on the front side for the reception of a plate, X or X', which is held between the said arms and the retaining-lever I, the latter having a shoulder, *m*, from which the plate is suspended, while its wings

enter openings in the plate X or X', and thus prevent the lateral displacement of the same.

The retaining-lever is prevented from turning laterally when adjusted to a vertical position by lugs *m'* of the work-plate, between which the upper end of the said lever is inserted. (See Fig. 6.)

The plate X, which is intended to be used when the usual chain-stitch is to be formed, has on its inner side a tongue, *n*, and on one edge a hook or notch, *n'*, and the plate X', which is to be used for the lock-stitch, has also a notch, *n'*, and a case, *t*, for receiving a bobbin. Each of these plates, it should be understood, when suspended from the shoulder *m* of the lever I, is retained so loosely between the latter and the arms *jj* that a loop of thread can be readily passed around them.

The fixed arm B of the machine is furnished at its outer end with the usual head or enlargement, J, in which are arranged to slide two vertical bars, K and L, which terminate at their lower ends in a presser-foot, K', and feeding-dog L', the lower end of the bar L passing through an oblong slot in the head J, which permits the said arm and its dog L' to be moved laterally to a sufficient extent to effect the required feeding of the work when the presser-foot is raised. (See Fig. 8.)

One arm of a bell-crank lever, M, which is hung to the bar L, projects downward and embraces with its forked end a pin, *p*, of the same bar, L, and the opposite slotted arm of the said lever is connected to the presser-foot bar K by a pin, *p'*.

A spring, *q*, attached to the arm B, bears upon the presser-foot arm, and has a constant tendency to maintain the same in contact with the work-plate *a*.

The bell-crank lever M is operated in such a manner as to raise the presser-foot and operate the feed-bar by means of an arm, P, which partly embraces the rear end of the needle-arm, and is hung to the fixed arm B at the point *q'*.

The presser-foot and feed-bar may be raised simultaneously from the work-plate by means of a lever, Q, hung to the upper end of the bar K.

One arm of a lever, *r*, which is hung to the head J, embraces the pin *p* of the bar L, and its opposite arm projects outward in the path of the needle-arm D, so that on the descent of the latter the said lever may be turned, and thus move the dog L' laterally in the direction of the arrow, Fig. 9, prior to a fresh feeding of the work.

Operation: Motion in the direction of the arrow, Figs. 1 and 2, is imparted to the driving-shaft, and is transmitted through the devices described to the needle-arm D, arm P, and to the loop-catcher G, the latter, owing to the longitudinal movement imparted to it by the cam *h*, traveling in a path represented by the line *yy*, Figs. 1 and 8, this path being inclined in respect to the center of the driving-

shaft and to the inclined plate X or X', it crossing the latter in the manner plainly indicated in the drawings.

The inclination of the path of the loop-catcher in respect to the plate X or X' forms the main peculiarity of this machine, it enabling the loop of the needle-thread to be carried entirely around the said plate by the loop-catcher without the aid of other devices, and either the common chain or lock stitch to be formed, as I will now proceed to describe.

In order to form the chain-stitch, it is first necessary to introduce the plate X between the retaining-lever I and the arms *jj*. This may be readily done by drawing the lever forward and away from the arms and turning it to one side, after which the plate is placed against the arms *jj* and the lever again adjusted to its position, so that the plate may be loosely suspended from the shoulder *m*.

The needle *s*, furnished with thread from a spool, *u*, is now caused to descend through the fabric and hole in the work-plate, so as to form a loop in the path of the loop-catcher, as shown in Fig. 11. This loop is seized by the hook *i* of the loop-catcher, and is carried by the same over the notch or shoulder *n'* of the plate X, and then entirely around the latter, as seen in Fig. 12. While the loop is being thus carried around the plate X that portion of the same on the rear side of the said plate is gradually drawn over the tongue *n*, which so distends the loop as to permit the needle to descend a second time and form a second loop between the tongue and plate X. This second loop is seized by the hook *i* of the loop-catcher, as shown in Fig. 13, and is carried around the plate in the same manner as before, the first loop in the meantime being drawn over the end of the tongue *n*, freed from the loop-catcher, drawn up into the fabric, and its slack taken up to form the second loop and stitch. (See Fig. 14.) In order to form the ordinary lock-stitch, the plate X must be removed and the plate X' inserted in its place, the case *t* of the latter containing a bobbin of under thread. The loop of needle-thread is seized in the same manner as before by the hook *i* of the loop-catcher, and is carried by the same over the notch or shoulder *n'* of the plate, and then entirely around the latter, it being thus interlocked with the under thread in a manner which will be readily understood on referring to Figs. 15, 16, and 17; but as it is not necessary in forming this stitch that the loop of needle-thread should be distended prior to each descent of the needle the tongue *n* is dispensed with.

Another important feature of this machine is the peculiar method of operating the presser-foot and feeding mechanism, the latter being what may be termed a "two-motion" feed, and always remaining in contact with the work, but exerting a pressure upon the latter only when moving forward. Thus when the needle reaches the limit of its upward movement and it becomes necessary to feed the work forward the arm P strikes and raises the slotted arm

of the bell-crank lever M, so that the presser-foot is raised from the work and its spring *g* compressed. During the first part of this movement, or while the lost motion at the forked end of the lever M is being taken up, the pin *p'* serves as a fulcrum for the said lever, so that the feeding-dog is necessarily depressed. During the latter portion of the movement, however, the lever M is turned upon its fulcrum *z*, and, the pin *p* being struck by the same, the feeding-dog is urged forward to effect the required feeding of the work. Should the pressure of the spring *g*, acting through the presser-foot bar and lever M, not be sufficient to return the feeding-dog to its original position, the same end will be attained on the descent of the needle-bar and consequent operation of the lever *r*.

I claim—

1. The combination of the needle-arm disk *e*, oscillating on the arm, and secured by the headed bolt *e'*, yoke *d*, driving-shaft, and eccentric *c*, all arranged and operating as described.

2. The yoke *d*, attached to or forming part of the disk *e*, and having a pin, *e'*, fitted to and arranged to turn in the needle-arm, and confined thereto by the key *f* and set-screw *f'*, all substantially as set forth.

3. The rotating reciprocating loop-catcher arranged on and revolving with the driving-shaft, but in a path inclined in respect to the center of that shaft, in combination with a

plate, X or X', placed opposite the end of the said shaft, whether that plate is arranged for carrying the spool of under thread for making the lock-stitch or whether the plate is arranged for aiding in making the common chain-stitch.

4. The plate X', carrying the spool of under thread, and having on one edge a notch or shoulder, *n'*, all substantially as set forth.

5. The combination of the plate X, shoulder or notch *n'*, and tongue *n*.

6. In combination with the said arms *jj*, the retaining-arm I, constructed substantially as described.

7. The said retaining-arm I, in combination with the spring sliding bar H.

8. The combination, substantially as herein described, of the bell-crank lever M with an arm, P, hung to the fixed arm B and operated by the needle-bar.

9. The two forked levers *r* M, one pivoted to the bar L and the other to a stationary part of the machine, and constructed and operating in connection with the bar K and the needle-arm, as specified.

In testimony whereof I have signed my name to this specification in the presence of two subscribing witnesses.

THOMAS LAMB.

Witnesses:

JOHN WHITE,  
HARRY SMITH.