

V. W. MASON, JR.
 CRUSHER HEAD.
 APPLICATION FILED OCT. 20, 1910.

993,783.

Patented May 30, 1911.

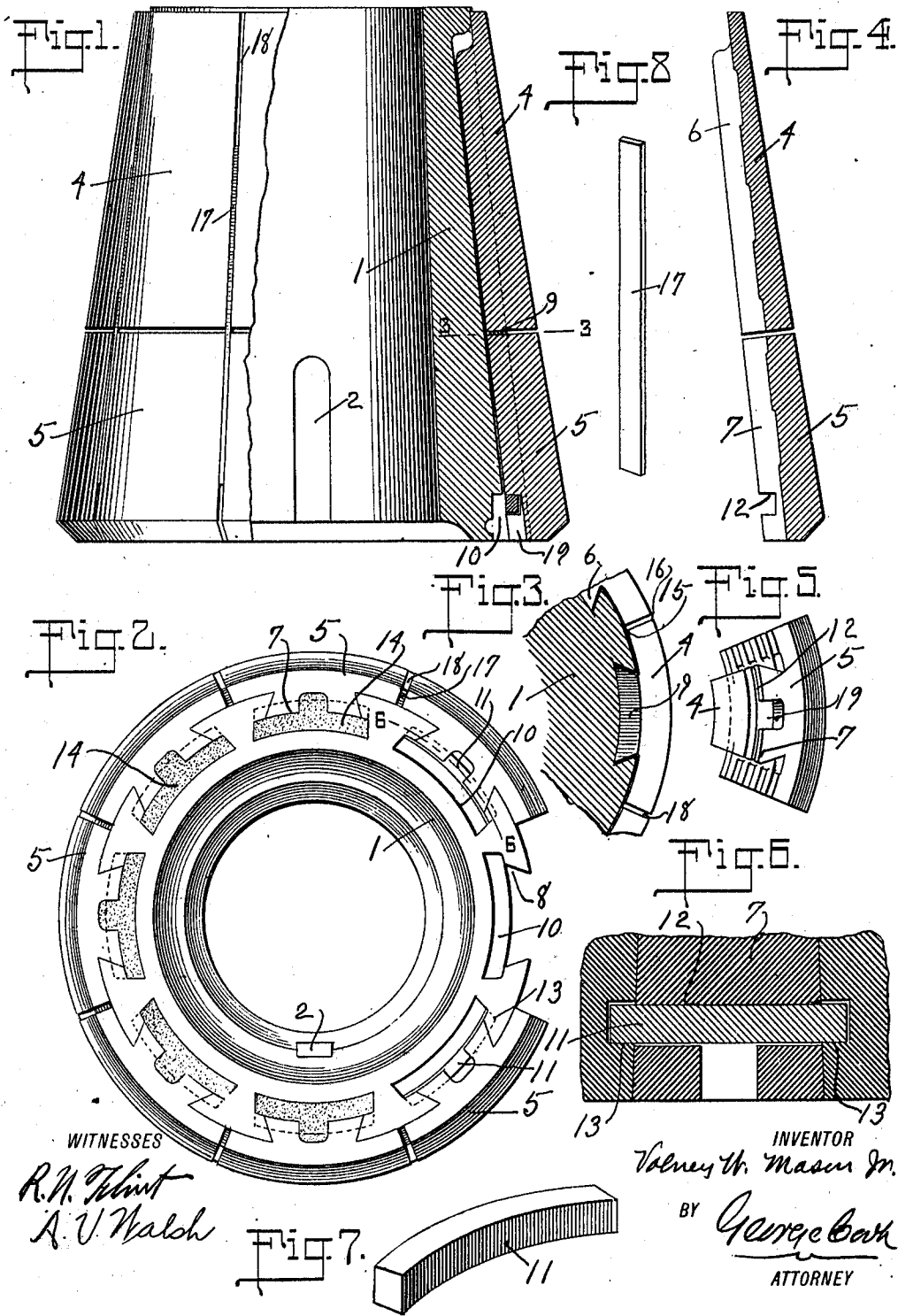

WITNESSES
R. N. Thint
A. V. Walsh

INVENTOR
V. W. Mason Jr.
 BY *George B. ...*
 ATTORNEY

UNITED STATES PATENT OFFICE.

VOLNEY W. MASON, JR., OF NEW YORK, N. Y., ASSIGNOR TO EDGAR ALLEN AMERICAN MANGANESE STEEL COMPANY, OF AUGUSTA, MAINE, A CORPORATION OF MAINE.

CRUSHER-HEAD.

993,783.

Specification of Letters Patent. Patented May 30, 1911.

Application filed October 20, 1910. Serial No. 588,157.

To all whom it may concern:

Be it known that I, VOLNEY W. MASON, Jr., a citizen of the United States, and a resident of New York, borough of Manhattan, in the county of New York and State of New York, have made and invented certain new and useful Improvements in Crusher-Heads, of which the following is a specification.

10 My invention relates to an improved grinding or crushing head designed for use with gyratory head grinding or crushing mills, although certain of the features of my improved crushing head may be used with advantage in the grinding heads of mills of other types.

15 The grinding or crushing heads of mills of the type above referred to are commonly covered or faced with a plurality of plates or segments formed from a hard and tough material such as manganese steel, and more specifically stated, my invention relates to such a facing, the object thereof being to provide a spacing composed of a plurality of segments designed and arranged with reference to securing a maximum service for each segment and to as great an extent as possible, maximum service for every part of each segment exposed to the action of the material being crushed.

20 With the above objects in view, my invention consists in the improved grinding or crushing head illustrated in the accompanying drawing, described in the following specification, and particularly claimed in the clauses of the concluding claim; it being understood, however, that while the preferred form of my invention is illustrated and described, the same is capable of such modifications as are obvious to those skilled in the art to which the invention relates.

25 In the drawing: Figure 1 is a view partly in section upon a vertical plane and partly in side elevation of the preferred embodiment of my invention; Fig. 2 is a view showing my invention as seen from a position beneath Fig. 1. Fig. 3 is a view showing a cross-section taken upon a transverse plane indicated by the line 3—3, Fig. 1, a part only of the head being shown; Fig. 4 is a view showing a section taken upon a plane extending longitudinally of two of the segments of my device; Fig. 5 is a view showing one of the plurality of lower segments in perspective; Fig. 6 is a view showing a sec-

tion at 6—6, Fig. 2; Fig. 7 is a view showing a securing key in perspective, and; Fig. 8 is a view showing a separating strip in perspective.

In the drawing, 1 is a core circular in cross-section and having a central passage whereby it may be secured to the upper end of a gyratory shaft, or to a hub thereupon, by means of a key 2. The core 1 is formed from cast iron or steel of any suitable composition and the exterior surface thereof is provided with a plurality of removable segments formed from a suitable hard tough material adapted to resist to as great an extent as possible the action of the material being ground, manganese steel being the preferred material although other materials possessing hardness and toughness to a degree sufficient to endure the severe service to which the segments are subjected may be used.

The segments referred to are arranged in two zones or belts upon the exterior surface of the core 1, the reference numeral 4 being applied to the segments in the upper belt while 5 represents the segments of the lower belt; the segments which collectively form each zone being shown as of uniform length so that the two belts are separated upon a plane perpendicular to the axis of the core 1. The segments are provided each with a dovetailed projection upon their backs as shown at 6, 7, and the core 1 is provided with longitudinally extending dovetailed grooves 8 in which the dovetailed projections 6, 7 fit and whereby the segments are secured to the exterior surface of the core 1.

The segments referred to are removable from the core so that new segments may be substituted as those in use become worn, and the purpose of dividing the segments into an upper and a lower circumferentially extending series or belt is to permit the lower series of segments to be renewed without renewing the upper series; as it is found in use that the lower series of segments wear away much faster than the upper series, and have to be renewed more frequently than the upper. From this it follows that in crushing heads in which removable segments extend vertically throughout the entire length of the core the segments will have to be renewed as soon as the lower ends thereof have been worn to such an extent as to become unserviceable at which time, how-

ever, the upper ends of the segments would still be capable of considerable more use. By making the segments in two parts in accordance with my invention the lower segments may be renewed without renewing the upper segments, and a single series of upper segments used until they wear out during which two or more sets of the lower series of segments would be worn out.

10 From the construction above described, it will be seen that two segments, one of the upper series and one of the lower are secured in each groove 8, and the groove and projections 6, 7 are slightly tapered so that the segments wedge in the grooves as they are driven in place from the lower end of the head. A spacing strip 9 is interposed between adjacent ends of the projection 6, 7 as best shown in Fig. 3, whereby the segments in each groove are separated slightly from one another.

The lower end of the core 1 is provided with a series of recesses 10 into which a curved key 11 may be dropped, the projection 7 has a transverse groove 12, and the sides of the dovetailed grooves 8 are undercut at 13; whereby when the segments are properly seated in the grooves 8 the key 11 may be placed in the recess 10 and moved outward into the groove 12 which then registers with the undercuts 13, the ends of the key being beneath the overhanging end portions of the sides of the grooves 8. Some easily fusible metal is now poured into the recess 10, as shown at 14, whereby the keys 11 will be securely held in position as will be understood.

The segments of each series above referred to are preferably separated from one another whereby a groove 18 is formed between adjacent segments of each series. Adjacent ends of the segments in line with one another being separated slightly by the spacing strip 9 as above explained, it will be seen that each segment is slightly separated from all other segments all around its edge. The purpose of this feature is to permit a slight flow of the material of the segments when in use, the particular material recommended being ductile to an appreciable degree and the flow of metal if not provided for being likely to cause buckling of the segments after there has been a flow of metal such that the edges of the segments contact with one another.

The arrangement above outlined wherein there is a space about each segment of a depth corresponding with the thickness of the segments radially is deemed preferable, as in such cases the material at the back of segments may flow circumferentially from the edge 15, which flow I have found to have occurred in certain cases where the crusher head has been subjected to extremely heavy duty. Ordinarily, however, the prin-

cipal flow of the metal of the segments is at their outer surface, the metal at the edges 16 flowing circumferentially due to the action of the segments upon the material being ground. When such a flow only is to be expected I prefer to place spacing strips 17 in the grooves 18, said strips extending either throughout the entire or a part only of the length of said grooves and said strips extending from the surface of the core outward in said grooves, a part of the way only to the working surface of the segments, so that the material at the surface and edge of the segments may flow over the outer edge of the separating strips.

In renewing the segments the easily fusible metal 14 is melted out and a wedge driven between the key 11 and the segment, the recess 19 at the lower end of the lower segments permitting this, and the key removed. The upper and lower segments are now driven down by blows applied to the upper end of the upper segment until the lower segment has been loosened, after which a new lower segment is placed in position and both segments driven into their proper position, the upper segment not ordinarily being removed from the core when a new lower segment only is to be placed in position. The lower segment may also be removed by driving a wedge between the upper and lower segments. The upper segment is obviously removed by continuing the driving operation above outlined whereby both segments are driven down to remove the lower.

Having thus described my invention, I claim and desire to secure by Letters Patent:

1. In a crusher head, a core having a series of vertically extending grooves; a series of circumferentially arranged segments spaced apart from one another and occupying the upper portion of the exterior surface of said core, and having each a rib adapted to enter one of the grooves aforesaid and to cooperate therewith to hold the segments in place upon the core; a second series of circumferentially arranged segments spaced apart from one another and occupying the lower portion of the exterior surface of said core, and having each a rib similar to the ribs of said first mentioned segments; and means interposed between adjacent ends of aligned segments of said two series of segments whereby they are spaced apart from one another.

2. In a crusher head, a core; a series of circumferentially arranged segments secured to the exterior of said core and extending through a part only of the length thereof; spacing strips interposed between adjacent edges of said segments; a second series of circumferentially arranged segments secured to the exterior of said core and extending through the remaining portion of the length

thereof; spacing strips interposed between adjacent edges of said second series of segments; and spacing strips interposed between adjacent ends of the segments of said two series of segments.

5 3. In a crusher head, a core; a series of circumferentially arranged segments secured to said core and occupying the upper portion of the exterior surface thereof; and a
10 second series of circumferentially arranged segments secured to said core and occupying the lower portion of the exterior surface thereof; each of said segments being spaced apart from adjacent segments so as to leave

a space between the edge of each individual segment of the edges of adjacent segments; and spacing strips located in the spaces thus formed, said strips extending from the bottom of said spaces and terminating below the outer surface of said segments.

Signed at New York, borough of Manhattan in the county of New York and State of New York this 15th day of October A. D. 1910.

VOLNEY W. MASON, JR.

Witnesses:

R. N. FLINT,
A. V. WALSH.

Copies of this patent may be obtained for five cents each, by addressing the "Commissioner of Patents, Washington, D. C."
