

L. WECKESSER.
NUT MAKING MACHINE.

No. 45,446.

Patented Dec. 13, 1864.

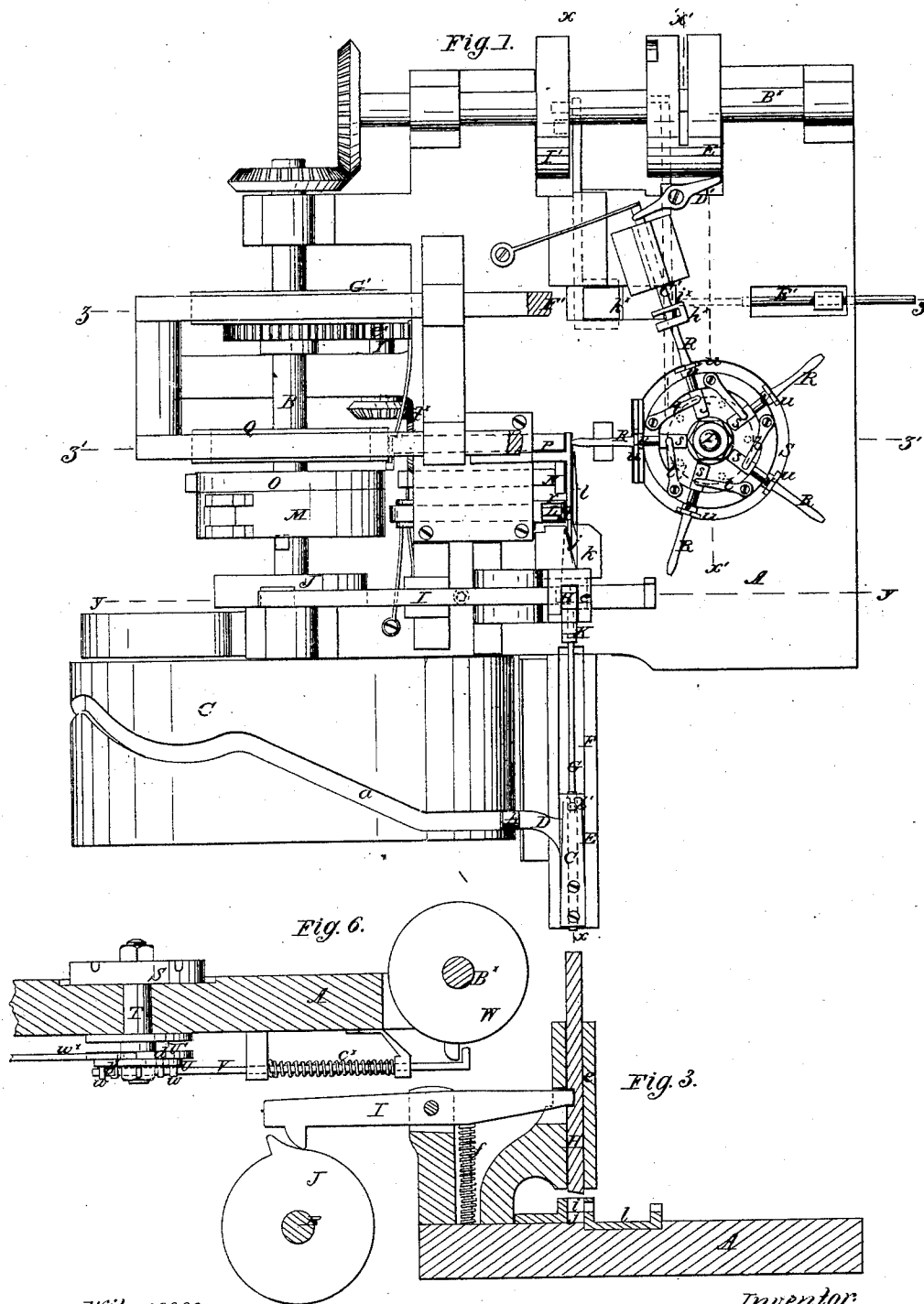

Witnesses:
L. D. Hoff
Henry & Co.

Inventor:
Louis Weckesser
by *Munn & Co.*
Atty.

L. WECKESSER.
NUT MAKING MACHINE.

No. 45,446.

Patented Dec. 13, 1864.

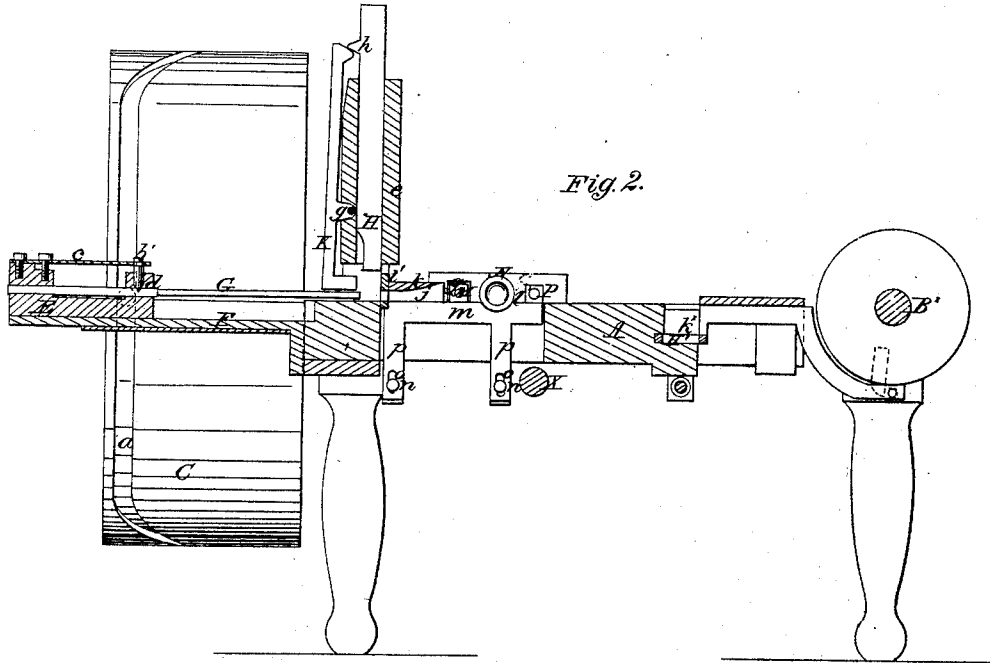

Fig. 2.

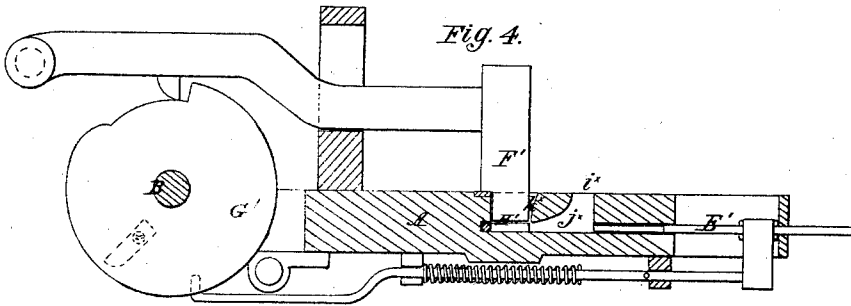

Fig. 4.

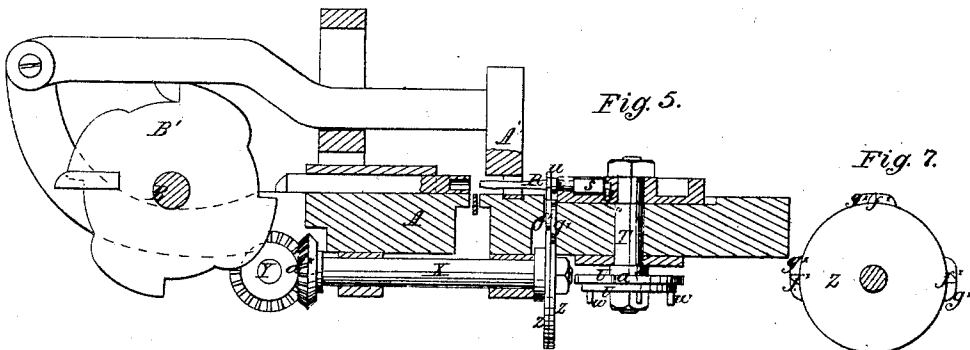

Fig. 5.

Fig. 7.

Witnesses:
C. D. Smith
Edward B. Smith

Inventor:
Lewis Weckesser
per Munnell
Attorney.

UNITED STATES PATENT OFFICE.

LEWIS WECKESSER, OF NEW HAVEN, CONNECTICUT.

IMPROVEMENT IN NUT-MAKING MACHINES.

Specification forming part of Letters Patent No. 45,146, dated December 13, 1864.

To all whom it may concern:

Be it known that I, LEWIS WECKESSER, of New Haven, in the county of New Haven and State of Connecticut, have invented a new and Improved Machine for Making Nuts; and I do hereby declare that the following is a full, clear, and exact description thereof, which will enable others skilled in the art to make and use the same, reference being had to the accompanying drawings, forming part of this specification, in which—

Figure 1 is a plan or top view of my invention; Fig. 2, a vertical section of the same taken in the line *x x*, Fig. 1; Fig. 3, a vertical section of the same taken in the line *y y*, Fig. 1; Fig. 4, a vertical section of the same taken in the line *z z*, Fig. 1; Fig. 5, a vertical section of the same taken in the line *z' z'*, Fig. 1; Fig. 6, a vertical section of the same taken in the line *x' x'*, Fig. 7; Fig. 7, a detached view of two wheels pertaining to the same.

Similar letters of reference indicate like parts.

This invention consists in a novel and simple device for gaging the bar from which the blanks are cut previous to the cutting off of each blank from the bar, so as to insure the blanks being of the same size or of uniform dimensions.

The invention also consists in the peculiar construction and arrangement of parts whereby the whole operation of punching and forging the blanks is brought within a very limited space and a very simple device obtained for the desired purpose, and one possessing a number of advantages, as hereinafter set forth.

A represents a bed-plate, at one end of which there is a driving-shaft, B, from which all the working parts of the machine are driven.

C is a cam, placed on one end of the shaft B, and formed of a wheel provided with a zigzag groove, *a*, in which a friction roller, *b*, on an arm, D, works, said arm being attached to a slide, E, which works within a grooved bar, F, attached to the bed-plate A. The slide E has a reciprocating motion imparted to it by means of a cam, C.

G is a rod or shover, which is fitted horizontally in the slide E, and is retained therein by a catch formed of a pin, *b'*, and a spring, *c*, the pin being attached to the end of the spring, and the latter having a tendency to keep the pin in a notch, *d*, in the rod or shover,

as shown in Fig. 2. In case the rod G meets with any resistance in the prosecution of its work, the pin *b* will slip out of the notch *d* in the rod and prevent the latter from being bent or broken.

H represents a cutter, which is fitted in a vertical guide, *e*, on the bed-piece A, and is operated by means of a lever, I, from a cam, J, on the shaft B, said cam forcing down the cutter, while a spring, *f*, raises it. (See Fig. 3.)

At one side of the guide *e* there is a lever, K, having its fulcrum at *g*. This lever is operated by means of a projection, *h*, at one side of the cutter H, near its upper end. (See Fig. 2.) This projection acts upon the lever K before the cutter acts upon the bar from which the blanks are cut, and causes the bar which is placed underneath the cutter to be compressed to a certain or uniform width previous to each cut, therefore causing the blanks to be cut off from said bar of equal size. The lever K presses the bar against a plate, *i*, and when a blank is cut off by the cutter the former drops down below said plate and in line with an opening or passage, *j*, in a plate, *k*. This passage *j* is made of spiral form, and the blank is forced through it by the rod or shover G, which is moved at the proper time by the cam C, operating the slide E. The spiral opening or passage *j* turns the blank from a horizontal to an edgewise position and forces it into a narrow chamber, *l*, the bottom of which is composed of an adjustable bar, *m*, which is narrower than the chamber *l*, to admit of an opening at each side for the escape of scales and dirt or trash. (See more particularly Fig. 1.) This bar *m* is rendered adjustable by means of set-screws *n n*, passing through oblong vertical holes *o o* in bars *p p*, as shown in Fig. 2.

The blanks are punched and their face sides rounded in this chamber *l*. The punch L is operated by a cam, M, on the shaft B, and it works through a fixed guide-plate, *g*, and within a box, *r*, which has also a sliding motion, and is operated from the same cam M. The box *r* grasps the blank and holds it in a proper relative position with the punch before the latter is shoved through the blank, thereby insuring the latter being punched centrally.

The facing punch or tool N is operated from a cam, O, on the shaft B, and simply gives a rounded or convex form to the face side of the

nut. The blank is forced from N, directly in front of a slide, P, which is operated from a cam, Q, on shaft B.

The slide P shoves the blank on one of a series of arbors, R, fitted radially in a horizontal wheel, S, on the bed-piece, and in such a manner that they may turn in said wheel. These arbors have each a square, s, at their inner ends, upon which springs t on the wheel S bear, said springs preventing the arbors from turning casually, and each arbor has a small spur-wheel or wiper, u, upon it, which adjoin small circular collars v. (Shown in Fig. 1.)

The wheel S is placed on a shaft, T, which extends down through the bed-piece A, and has two wheels, U U', upon it, one of which, U, is provided with pendent teeth w at equal distances apart, and the other provided with notches a^x in its periphery, into which a pawl, w^x , catches, to prevent the casual turning of the wheel S.

V is a rod having a hook, b^x , at its inner end to engage with the teeth w of wheel U and rotate the same. This rod V is operated from a cam, W, on shaft B^x, the return motion being given it by a spring, c^x . (See Fig. 6.)

X represents a shaft underneath the bed-plate A, which is driven by gears d^x from a shaft, Y, the latter being driven by gears e^x from the shaft B. On the outer end of the shaft X there are placed two wheels, Z Z', one of which, Z, is provided with teeth f^x , and the other, Z', with projections g^x , a projection being by the side of each tooth. (See Fig. 7.)

The teeth f^x of the wheel Z serve to rotate the arbors R, said teeth engaging with the spur-wheels or wipers u, while the projections g^x raise the arbors to free the blanks on them from the bed-piece.

The blanks are forged on their edges, while on the arbors R, by means of a hammer, A', operated from a cam, B', on the shaft B, and each arbor, by the mechanism above described, is turned three times, so as to cause all the sides of the blank to be smoothed or forged under the action of the hammer. The wheel S is turned after each blank is thus forged by means of the rod V acting on the teeth w of wheel U, and by this movement of the wheel S the forged blank is brought within recesses in plates h^x at the end of a slide, C', which is operated by a lever, D', and a cam, E', on the shaft B^x, driven by bevel-gears from shaft B. The plates h^x draw the forged blank off from its arbor R while a succeeding blank is being brought under the hammer A', and the blank is drawn by the plates h^x over a hole, i^x , through which it falls into a passage,

j^x , of spiral form, and is forced through said passage by a rod, E', into a chamber, k^x , the spiral passage j^x , turning the blank from an edgewise to a flat position, so that it may receive a finishing-stroke from a hammer, F', operated from a cam, G', on shaft B. The finished blank is discharged from the chamber k^x by means of a forked plate, H', operated by a cam, I', on shaft B^x.

Thus by this arrangement I obtain a nut-machine which is very compact, and has all its parts exposed to view, so that the attendant can see the whole operation throughout.

Having thus described my invention, I claim as new and desire to secure by Letters Patent—

1. The lever K, arranged relatively with the cutter H, and to operate in connection therewith, substantially, as shown, for the purpose of rendering the blanks uniform in size, as set forth.

2. The securing of the rod or shover G in its slide E by means of the spring c and pinor shover, in case of the latter meeting with any resistance in its work, becoming disengaged from the slide, as herein described.

3. The spiral passages j^x , for the purpose of turning the nuts, respectively, from a flatwise to an edgewise position, and vice versa, as described.

4. The adjustable bar m, forming the bottom of the chamber l, and of less width than the same, to admit of the escape of scales, dirt, &c., therefrom, as set forth.

5. The combination of the punch L and box r, to insure the central punching of the blank, as specified.

6. The horizontal intermittingly rotating wheel S, provided with a series of radial arbors, R, to receive the blanks and turn the same, so that its several sides will be consecutively acted upon by the hammer A', substantially as set forth.

7. The plates h^x at the end of the slide C', for the purpose of drawing the forged blanks from the arbors R, as set forth.

8. The wheels Z Z', provided, respectively, with the teeth f^x , and projections g^x , in connection with the spur-wheels or wipers u and the collars v on the arbors R, for the purpose of raising and rotating the arbors to admit of the sides of the blanks being forged consecutively, as described.

LEWIS WECKESSER.

Witnesses:
E. SIEGEL,
J. A. WOOD.