



(51) International Patent Classification:

B32B 21/08 (2006.01) *B32B 37/15* (2006.01)
B32B 27/08 (2006.01) *B32B 38/06* (2006.01)
B32B 27/30 (2006.01) *B32B 38/00* (2006.01)
B32B 27/32 (2006.01) *B32B 37/24* (2006.01)
B32B 27/36 (2006.01) *E04F 15/10* (2006.01)
B32B 37/04 (2006.01) *B44B 5/00* (2006.01)
E04F 13/18 (2006.01) *B44C 1/24* (2006.01)
B32B 37/14 (2006.01) *B44C 5/04* (2006.01)
B32B 37/10 (2006.01)

(21) International Application Number:

PCT/IB2015/055826

(22) International Filing Date:

31 July 2015 (31.07.2015)

(25) Filing Language:

Dutch

(26) Publication Language:

English

(30) Priority Data:

62/031,554 31 July 2014 (31.07.2014) US

(71) Applicant: UNILIN, BVBA [BE/BE]; Ooigemstraat 3, B-8710 Wielsbeke (BE).

(72) Inventor: NAEYAERT, Christophe; Wetstraat 3A, B-8490 Jabbeke (BE).

(74) Agents: VAN HOOYDONCK, Guy et al.; Unilin Industries BVBA, Ooigemstraat 3, B-8710 Wielsbeke (BE).

(81) Designated States (unless otherwise indicated, for every

kind of national protection available): AE, AG, AL, AM, AO, AT, AU, AZ, BA, BB, BG, BH, BN, BR, BW, BY, BZ, CA, CH, CL, CN, CO, CR, CU, CZ, DE, DK, DM, DO, DZ, EC, EE, EG, ES, FI, GB, GD, GE, GH, GM, GT, HN, HR, HU, ID, IL, IN, IR, IS, JP, KE, KG, KN, KP, KR, KZ, LA, LC, LK, LR, LS, LU, LY, MA, MD, ME, MG, MK, MN, MW, MX, MY, MZ, NA, NG, NI, NO, NZ, OM, PA, PE, PG, PH, PL, PT, QA, RO, RS, RU, RW, SA, SC, SD, SE, SG, SK, SL, SM, ST, SV, SY, TH, TJ, TM, TN, TR, TT, TZ, UA, UG, US, UZ, VC, VN, ZA, ZM, ZW.

(84) Designated States (unless otherwise indicated, for every

kind of regional protection available): ARIPO (BW, GH, GM, KE, LR, LS, MW, MZ, NA, RW, SD, SL, ST, SZ, TZ, UG, ZM, ZW), Eurasian (AM, AZ, BY, KG, KZ, RU, TJ, TM), European (AL, AT, BE, BG, CH, CY, CZ, DE, DK, EE, ES, FI, FR, GB, GR, HR, HU, IE, IS, IT, LT, LU, LV, MC, MK, MT, NL, NO, PL, PT, RO, RS, SE, SI, SK, SM, TR), OAPI (BF, BJ, CF, CG, CI, CM, GA, GN, GQ, GW, KM, ML, MR, NE, SN, TD, TG).

Declarations under Rule 4.17:

— as to applicant's entitlement to apply for and be granted a patent (Rule 4.17(ii))

Published:

— with international search report (Art. 21(3))

(54) Title: METHOD AND INSTALLATION FOR MANUFACTURING A FLOOR COVERING PRODUCT AND FLOOR COVERING PRODUCT OBTAINED HEREBY

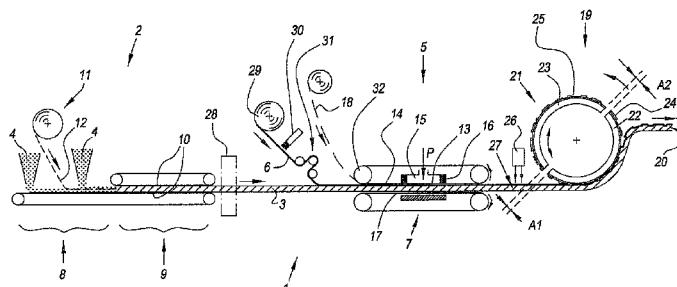

Fig. 1

(57) Abstract: Method for manufacturing a floor covering product, wherein this method comprises at least a first step of forming a single- or multi-layered substrate (3) by consolidating synthetic material-based starting material (4), as well as comprises a second step after the first step, which preferably is performed in line with the first step, wherein at least one continuous film (6) is laminated onto the substrate (3), characterized in that said laminating is performed by means of a belt press (7).



Method and installation for manufacturing a floor covering product and floor covering product obtained hereby.

- 5 This invention relates to a method and installation for manufacturing a floor covering product and to a floor covering product obtained thereby.

More particularly, the invention relates to the manufacture of floor covering products with a synthetic material-based substrate upon which at least one film is
10 laminated.

The film laminated thereon may be of any kind. In the first place, however, a printed film is meant, more particularly a decor film. However, this may also relate to another film, such as a film functioning as a wear layer. Also, a plurality of films
15 may be laminated thereon, for example, the decor film with thereabove a film functioning as a wear layer.

In particular, however, not restrictive, the invention aims at the manufacture of floor covering products, the substrate of which is formed of thermoplastic synthetic
20 material.

More particularly, the invention relates to the production of synthetic material-based floor panels which can be provided as a floor covering on a supporting underlying floor. Generally, such floor panels are known as vinyl tiles, also called
25 LVT (Luxurious Vinyl Tiles), as up to now they mostly are realized on the basis of vinyl. Although the invention in the first place also aims to vinyl tiles, it is clear that it does not restrict itself to this synthetic material, however, is also applicable to tiles, more particularly floor panels of which at least the substrate is realized on the basis of other synthetic materials, for example, polypropylene (PP), polyethylene (PET) or polyurethane (PUR). Preferably, this relates to semi-rigid or soft synthetic
30 materials, which to this aim may be provided, for example, with plasticizers.

Said film, films, respectively, laminated on the substrate, may consist of any suitable synthetic material, however, preferably a PVC film is applied. Other
35 examples are PU, PP and PET films. In the case of a PP film, this may relate, for example, to an oriented polypropylene film. In the case of a PVC film, this preferably relates to a hard PVC film, namely, a film on the basis of PVC without

plasticizer or with an amount of plasticizer of less than 5 percent by weight. Such hard PVC film can be printed with a higher precision, certainly in the case of a print performed with water-based inks. In such case, a drying operation by means of heat supply is desirable in the printing process, however, by choosing hard PVC the possible expansion of the film is restricted. The wear layer preferably also comprises a thermoplastic material, such as soft or hard PVC, PU, PP or PET. Preferably, the transparent thermoplastic wear layer is free from solid additives, such as ceramic particles for promoting wear resistance, although this kind of particles is not excluded. However, the inventor has found that they may be omitted in view of obtaining a good transparency, whereas still an acceptable wear resistance is kept.

According to an alternative, it is not excluded that the printed decor or the print may be provided on the underside of the wear layer, wherein then no separate film will be necessary for applying the decor. If indeed specifically a film is applied for the decor, the print can be provided either on the upper side only, or on the lower side only, or both on the upper side and the lower side.

Such tiles actually relate to floor panels which either may be square, or rectangularly oblong, or may have any other shape.

Herein, the possibly provided decor may form a representation of a wood motif or stone motif, or any other motif, such as a fancy pattern.

On the surface of such products, for example, said vinyl tiles, a structure may be provided, formed by impressions, such as a wood or stone structure, respectively. Other impressions may be applied as well, for example, in order to imitate deeper-located joints or the like. Further, it is also known that such structure can be performed in correspondence with the printed motif, which in English is called "registered embossed". By such "correspondence", as is known, has to be understood that the structure is performed according to a motif which is adapted to the printed motif and that consequently the impressions cannot be provided randomly in respect to the printed motif.

The invention aims at a method with which such and other floor covering products can be realized in a particularly smooth manner, such by successively linking very

specific production steps, wherein at the same time a good, thus, high-quality lamination of a film on a substrate in such production process is striven for.

To this aim, the invention, according to a first aspect, relates to a method for manufacturing a floor covering product, wherein this method comprises at least a first step of forming a single- or multi-layered substrate by consolidating synthetic material-based starting material, as well as comprises a second step after the first step, which preferably is performed in line with the first step, wherein at least one continuous film is laminated onto the substrate, characterized in that said laminating is performed by means of a belt press. By performing the lamination after the consolidation of the substrate, and also by realizing this lamination by means of a belt press, a high-quality end product can be obtained with great certainty. As, during laminating, it is started from an already substantially consolidated product, optimum starting conditions for laminating are created. As, during laminating, a belt press is used, wherein thus a contact is maintained over a longer distance, possible inaccuracies will be flattened further and/or a good lamination can be guaranteed, with a minimum of deformations.

Preferably, the one or more films in transport direction are clamped between a belt of the belt press and the substrate at least over a length of at least 0.5 m and still better at least 1 meter.

It is noted that continuous lamination processes have already been known previously, however, not with the use of a belt press.

Further characteristics of the invention are described in the appended claims.

According to the most preferred embodiment, the forming of the substrate is performed by means of a strewing process, wherein the synthetic material-based starting material is strewn as a granulate or in any other manner and subsequently is consolidated in a press device. It has become apparent that a strewing process offers a good starting basis in order to subsequently apply thereto a lamination according to the invention. So, for example, a very smooth surface is obtained after compressing the strewn material, by which a good underlying surface is obtained for laminating the continuous film.

Preferably, the strewn granulate or the like is consolidated by means of a continuous press, more particularly a belt press, and in particular a double-belt press. The use of a belt press also promotes the smoothness of the product obtained therefrom.

5

However, the foregoing does not exclude that according to an alternative the substrate can be formed by means of extrusion, preferably an extrusion in which the synthetic material-based material, more particularly starting material, is extruded in a layer shape, or by means of a comparable process, wherein possibly a plurality of layers are thermally laminated on top of each other.

10

Preferably, the step of forming the substrate shows one or more of the following characteristics:

- that in the starting material one or more other materials than synthetic material are incorporated, such as additives and/or fillers, amongst which chalk;
- that reinforcement material, more particularly fibers, are incorporated into the substrate, preferably in the form of one or more local layers in the form of a fiber mat, non-woven or fabric, for example, in the form of glass fiber, such as a glass fiber fleece, cloth or net.

15

20

Preferably, said laminating of the continuous film in the second step is performed by means of a double-belt press.

In particular, it is preferred that said laminating of the continuous film in said second step is performed by means of a belt press which is made as an isobaric press. This offers a considerable advantage. Hereby in fact a very uniform lamination can be effected.

25

More particularly, it is preferred that said laminating of the continuous film in said second step in the belt press is performed by means of a fluid pressure which is exerted on a surface of a belt of the belt press, more particularly in a zone along which this belt is moving.

30

Preferably, in said second step a double-belt press is applied, wherein the substrate and the continuous film are moved along between the two belts of the double-belt press, wherein the fluid pressure is exerted on the belt which is

35

situated on the side of the continuous film, whereas the other belt functions as a counter support.

5 According to an alternative possibility, for said laminating in said second step, instead of the aforementioned belt press use is made of another press, which press, however, is an isobaric press, more particularly is a press which presses the film directly or indirectly with a uniform fluid pressure over a surface of the substrate onto this latter. It is clear that any form of isobaric pressing process leads to an advantageous result.

10

Preferably, for creating the pressure in the press use is made of a gaseous fluid, more particularly air, or according to an alternative of a liquid, for example, oil.

15 From a practical point of view, it is preferred that said laminating of the film on the substrate is performed by fusion.

20 Thus, it is preferred that in order to provide for a fusion, the substrate and/or the film to be provided thereon by lamination are brought to a suitable temperature, before, during or after joining the substrate and the film. The value of the temperature to be applied is the value at which a fusion takes place and as such is known and/or can be determined by a person skilled in the art in a simple manner.

The aforementioned temperature can be effected, for example, by means of or at least in part by one or more of the following possibilities:

- 25 - by applying heat, which is present in the substrate, originating from said first step;
- by adding heat to the substrate and/or to the continuous film between the first and second steps or during the second step.

30 According to a preferred embodiment, during the second step heat is supplied via a heated roller placed at the starting point of the belt press, preferably a deflection roller of a belt of the press which comes into contact with the continuous film.

35 Towards the end of the lamination, preferably a cooling is provided in order to consolidate the assembly of substrate and film. To this aim, for said laminating use may be made of a fluid pressure which is directly or indirectly exerted on a surface of a belt of the belt press, wherein the cooling is performed via this fluid.

It is noted that said continuous film preferably is a decor film and more particularly a film which is provided with a print. Such print can be realized beforehand at a printer's, however, according to a preferred alternative of the invention, the film
5 forming the decor layer is printed directly, thus, during the manufacturing process, however, prior to laminating, preferably by means of a digital printer or printing unit. It is also not excluded to realize the print after laminating, or partially before and partially after, however, preferably before possible impressions for forming a relief are provided in the surface.

10

In a preferred embodiment, impressions are provided in the upper side of the floor covering product, too, more particularly in the same continuous process, preferably after laminating the continuous film onto the substrate.

15 Preferably, the floor covering product comprises a printed decor and the impressions are realized as so-called "in register" with the decor.

In a particular embodiment, the impressions are provided by means of a, whether or not multi-part, roller, which is provided with a relief on its surface.

20

More particularly, it is preferred that a roller is applied with, seen along the circumference, at least two segments which each are provided with a relief, wherein in circumferential direction the distance between at least two of these segments is adjustable in order to change the so-called "repeat" with which the
25 impressions are realized, wherein this "repeat" is adjusted and changed in function of the position of the decor.

Preferably, the method herein is also characterized in that the substrate and said continuous film, whether or not together with still other layers, form a material web
30 and that this material web is bent around the aforementioned roller, such that the cooperation between the relief and the material web at least takes place over an arc-shaped portion. More particularly, it is preferred that the material of the material web is kept in contact with the roller during at least 3 seconds, and still better at least 5 seconds. It is also preferred that the material web is supplied to
35 the roller in heated condition and that the roller is cooled.

Other techniques for providing impressions "in register" of course can also be applied, or different techniques can be combined, too.

5 According to a possibility of the invention, it is characterized in that said continuous film is a decor layer and that this film is subjected to a controlled stretching prior to laminating, in order to stretch the decor to a larger or lesser extent, in the width and/or length, such that the decor is adjusted in function of the desired final result.

10 The floor covering product can be provided with a translucent wear layer, for example, in the form of at least one film and/or in the form of at least one lacquer layer.

15 In a preferred application, the method is characterized in that the substrate and said continuous film, whether or not together with still other layers, form a material web and that this material web is cut to floor panels, more particularly to rectangular oblong or square panels or tiles.

20 According to a particular embodiment, the floor panels are formed such that they are free from coupling parts at their edges, wherein the floor panels are of the type which is intended for being installed according to the "loose lay" principle, or for being installed by means of gluing to the underlying surface.

25 According to another possibility, the method is characterized in that the floor panels are provided with coupling parts at their edges, whereby a plurality of such panels can be coupled to each other at their edges in a mechanical manner in order to thereby provide for a locking preferably horizontally as well as vertically.

30 The method of the invention preferably is applied for the production of so-called LVT tiles (Luxurious Vinyl Tiles) or comparable floor panels.

According to a variant of the invention, instead of using said continuous film, use is made of successive film sheets which are laminated on the continuously formed substrate.

35 Preferably, the substrate shows one or more of the following characteristics:

- the material of the substrate contains a thermoplastic;

- the material of the substrate contains a supple thermoplastic, more particularly a thermoplastic which is provided with a plasticizer;
- the material of the substrate is based on any of the following materials: polyvinyl chloride (PVC), polypropylene (PP), polyethylene (PET) or polyurethane (PUR);
- 5 - the material of the substrate contains one or more filler materials, for example, chalk;
- the material of the substrate, either across the entire thickness thereof, or across only a portion of the thickness thereof, substantially consists of a composite of synthetic material and wood particles, and more particularly WPC (Wood Plastic Composite), wherein for the synthetic material preferably use is made of any of the herein above-mentioned synthetic materials;
- 10 - the substrate consists of at least two layers, namely, a layer such as described in the preceding paragraph, and a layer which is free or substantially free from wood particles and substantially is based on synthetic material;
- 15 - the substrate contains a reinforcement layer, such as a glass fiber fleece or the like.

20

Preferably, the continuous film shows one or more of the following characteristics:

- it relates to a thermoplastic synthetic material film;
- it relates to a PVC film, PU film, PP film, or PET film;
- it relates to an oriented polypropylene film;
- 25 - it relates to a hard PVC film, namely, a film on the basis of PVC without plasticizer or with an amount of plasticizer of less than 5 percent by weight.

According to a particularly preferred aspect, the method is characterized in that the substrate, starting from its manufacture up to the forming of the final floor covering product, is handled in a flat state, or, during bending, is subjected exclusively to bending having a radius of more than 40 cm. In this manner, relatively thick material webs can be formed in a smooth manner.

According to the invention, it is not excluded that simultaneously, by which is intended in the same production process, or possibly precisely at the same time, two or more films, more particularly synthetic material films, are provided by means of said lamination.

By further combining very specific techniques with each other in preferred embodiments, as discussed herein above, a method is obtained which in many respects can be universally applied, wherein also a larger possibility is offered for realizing various products, starting from one and the same belt press, with minor adjustments, for example, with different features and/or of a different construction.

In a preferred embodiment, according to the invention floor covering products of a very small thickness as well as of a larger thickness, and thus more difficult to bend, can be realized. Practical values of thicknesses are 2 to 6 mm.

Although the invention in the first place relates to floor panels, it can also be applied for the production of wall-to-wall floor covering products, such as vinyl, which is marketed on rolls.

It is noted that of course it is not excluded to provide a backing layer or underlying layer on the underside of the substrate, such as a vapor-tight layer, for example, a thermoplastic film.

A lacquer layer can be provided as the uppermost layer of the floor covering product. Herein, this may relate, for example, to an UV- or an electron beam-hardening lacquer layer and/or to a PU lacquer layer. Such lacquer layer may replace said film functioning as a wear layer, however, may also be applied hereon as an additional layer.

Preferably, the invention, as already stated herein above, is applied for manufacturing floor panels, which are provided with mechanical coupling means, more particularly coupling parts, on the respective edges, which allow that two of such floor panels can be coupled to each other in such a manner that a locking is obtained in a vertical direction perpendicular to the plane of the coupled panels, as well as in a horizontal direction perpendicular to the coupled edge and in the plane of the panels. Preferably, the coupling means also show one or a combination of two or more of the following features:

- the feature that the mechanical coupling means or coupling parts substantially are made as a tongue and a groove bordered by an upper lip and a lower lip, wherein this tongue and groove substantially are responsible for the locking in said vertical direction, and wherein the tongue

- and the groove are provided with additional locking parts substantially responsible for the locking in said horizontal direction. Preferably, the locking parts comprise a protrusion on the lower side of the tongue and a recess in the lowermost groove lip. Such coupling means and locking parts are known, for example, from WO 97/47834;
- 5 - the feature that the mechanical coupling means or coupling parts press the coupled floor panels against each other, for example, in that these mechanical coupling means are realized with so-called pre-tension, as is known as such from EP 1 026 341. The tensioning force with which the floor panels are pressed against each other or towards each other may be obtained, for example, in combination with the above feature, by means of a lower lip, which is bent out in coupled position and which, trying to spring back, presses against the lower side of the tongue;
 - 10 - the feature that the mechanical coupling means allow a coupling by means of a horizontal, or quasi-horizontal, shifting movement of the panels towards each other;
 - 15 - the feature that the mechanical coupling means allow a coupling by means of a turning movement along the respective edges;
 - 20 - the feature that the mechanical coupling means allow a coupling by means of a downward-directed movement of a male coupling part having, for example, a tongue, up into a female coupling part having, for example, a groove, preferably in order to install such panels according to the so-called "fold-down" principle;
 - 25 - the feature that the mechanical coupling means, or at least the pertaining upper edge, is realized by means of a milling treatment with rotating milling tools.

Preferably, said coupling means are realized substantially in said substrate, more particularly at least in at least one of said two layers which, according to the invention, enclose the glass fiber layer. Preferably, said coupling means are provided by means of a milling treatment with rotating milling tools. Preferably, the floor panel of the invention relates to a rectangular, either oblong or square, panel which is provided with mechanical coupling means on both pairs of opposite edges.

35

Panels which are provided with coupling means preferably have a thickness of at least 2.5, still better at least 3 millimeters.

It is not excluded that, also as stated herein above, the invention is applied for panels which are free from coupling means or coupling parts at their edges, wherein these panels then are intended for being glued with their underside to the underlying surface or for being installed loosely. Such panels preferably have a thickness of less than 6, and still better less than 4 millimeters, however, preferably of more than 1.5 millimeters.

Prior to laminating said film onto the substrate, possibly a levelling treatment may be performed on the surface of the substrate. The levelling treatment may consist, for example, of a grinding treatment and/or providing one or more layers of plastisol. Preferably, this levelling treatment is performed in line with the steps of the substrate.

The present invention also relates to an installation for manufacturing a floor covering product, more particularly for realizing the aforementioned method, characterized in that it consists at least of a device for forming a single- or multi-layered substrate by consolidation of synthetic material-based starting material, as well as a device connected thereto for laminating at least one preferably continuous film on the substrate, wherein this latter device makes use of a belt press.

In a preferred embodiment, the installation is provided with a press with features as described herein above.

The installation possibly may comprise a device for forming impressions in order to provide the floor covering product with a relief on its surface, wherein for this device preferably use is made of a roller as described herein above.

The installation also may comprise a printing device, preferably a digital printer, with which a decor is printed on the continuous film, preferably while this film is supplied to the device for laminating.

Further, the installation may also comprise one or more additional devices and/or comprise additional provisions for effecting one or more operations of the herein above-described method.

According to a second aspect, the invention also relates to a method for manufacturing a floor covering product, wherein this method comprises at least a first step for forming a single- or multi-layered substrate by consolidating synthetic material-based starting material, as well as comprises a second step after the first step, which preferably is performed in line with the first step, wherein at least one continuous film is laminated on the substrate, and also comprises a third step, wherein impressions are formed in the surface, with the characteristic:

- that the forming of the substrate is performed by means of a strewing process, wherein the synthetic material-based starting material is strewn as a granulate and subsequently is consolidated in a press device; and
- that the impressions are provided by means of a roller, which is provided with a relief on its surface, wherein for this roller a roller is applied with, seen along the circumference, at least two segments, which each are provided with a relief, wherein in circumferential direction the distance between at least two of these segments is adjustable in order to change the so-called "repeat" with which the impressions are realized, wherein this "repeat" is adjusted and altered in function of the position of an applied decor.

According to this second aspect, the laminating step is of less importance and may take place in any manner. The combination of forming a substrate by means of a strewing process and the use of an adjustable roller for providing impressions in register already leads to a particularly smooth production process. All other characteristics which are described by means of the first aspect and the claims thereof, of course may also be applied in combination with the second aspect.

All partial features from the first aspect can be employed at choice in the method of the second aspect.

In the first as well as in the second aspect, of course the films to be laminated are thin films and preferably have a thickness of less than 1 mm, and still better less than 0.5 mm and even better less than 0.2 mm.

It is clear that the invention also relates to floor covering products such as obtained by the aforementioned methods and/or by the application of the aforementioned installation.

With the intention of better showing the characteristics of the invention, herein below, as an example without any limitative character, some preferred embodiments are described, with reference to the accompanying drawings, wherein:

5 Figure 1 schematically illustrates a possible embodiment of the method of the invention, as well as schematically represents the installation applied therewith;

 Figure 2 represents a variant.

10 In the accompanying figure 1, an installation 1 according to the invention is represented, which consists at least of a device 2 for forming a substrate 3 by consolidation of synthetic material-based starting material 4, as well as a subsequent device 5 for laminating at least one preferably continuous film 6 on the substrate 3, wherein this last-mentioned device 5, for the lamination makes use of
15 a belt press 7, such that the film 6 is pressed, at least over a well-defined distance, in contact with the substrate 3.

 The device 2 preferably is of the type wherein the substrate is formed by means of a strewing process, wherein the synthetic material-based starting material 4 is
20 strewn as a granulate in a strewing portion 8 of the device 2 and subsequently is consolidated in a press device or press portion 9. As represented schematically, this press portion 9 preferably consists of a double-belt press 10.

 The strewing portion 8 may be of a different construction and possibly may also
25 comprise supply means 11 for incorporating a reinforcement layer, such as a glass fiber fleece 12, into the substrate.

 As aforementioned and according to the first aspect of the invention, the device 5 comprises a belt press 7. In particular, it is preferred that this belt press 7 is made
30 as an isobaric press, wherein laminating the continuous film 6 in the belt press is performed by means of a fluid pressure P, which is exerted on a surface 13 of a belt 14 of the belt press 7. As represented schematically, to this aim a chamber 15 may be formed along this belt, which chamber is bordered by a frame or border 16, wherein in the thus formed chamber 15 a pressure can be built up, which pressure
35 acts on the respective portion of the belt 14. In this manner, a uniform pressure is realized during laminating, by which a smooth lamination is created.

It is clear that the belt press 7 preferably is a double-belt press having a second belt 17 which provides for the necessary support.

5 The use of an isobaric press shows the advantage that on the location where the actual lamination is performed, a very uniform compression takes place, by which stresses in the plane of the substrate and the film practically are excluded, which leads to a uniform lamination

10 It is represented schematically that also still another film 18 can be laminated along. In a practical embodiment, the film 6 will be intended for forming a decor layer, whereas the film 18 forms a wear layer. It is noted that it is not excluded to laminate, according a not-represented embodiment, the films 6 and 18 each by means of an own belt press 7, wherein then two belt presses 7 have to be installed one after the other.

15

It is noted that according to a not-represented variant, it is not excluded to apply an isobaric press, wherein the fluid presses directly on the respective film or films, without the intermediary of a belt or any other element.

20 Further, the method applied therewith may comprise also other steps, wherein the necessary devices and/or additional provisions to this aim then are integrated into the installation.

25 So, for example, according to an important preferred embodiment, the installation is provided with a device 19 for forming impressions in the floor covering product 20 to be formed. As represented in the accompanying figure, to this aim preferably use is made of a roller 21 with along the circumference at least two segments 22-23, which each are provided with a relief 24-25, whether or not the same relief, wherein in circumferential direction the distance A1-A2 between at least two of
30 these segments is adjustable in order to change the so-called "repeat" with which the impressions are realized, wherein this change preferably is performed in function of the position of the decor, this automatically, and with the intention of producing so-called "registered embossed" products.

35 At the entry of the device 19, a heating device 26, for example, by means of infrared radiation, can be provided for heating the upper side of the respective material layer or material web 27, preferably almost up to melting temperature, in

order to obtain that the impressions can be realized. The roller 21 can be cooled in order to consolidate the then realized impressions in the obtained form by the cooling down and stiffening of the material layer 27, the longer this material layer is in contact with the roller over a longer time.

5

Further, it is also represented schematically in the figure that the installation 1 also can be provided with a device 28 for subjecting the substrate at least on one side to an additional levelling treatment, such as, for example, a grinding machine.

10 As aforementioned, the film 6 is intended for forming a decor layer. To this aim, this film 6 can be supplied as a printed film from a supply roll 29. According to an alternative, however, printing may also take place on site by means of a device 30, more particularly a printing device and in particular a digital printer or printing unit.

15 Also, it is not excluded to provide a further device 31 for subjecting the film 6 to a certain stretching, preferably in a controlled manner, for adjusting the length and/or width of the decor, for example, in function of an impression pattern to be provided afterwards.

20 In this manner, for example, by means of the device 31 an additional adjustment of the width of the decor can be provided for, whereas by means of the device 19 an adjustment of the length is provided by adapting the average so-called "repeat".

It is noted that it is not excluded to first have the belt press 7 be preceded by one
25 or more pressing rollers, although this preferably shall not be the case.

At the entry of the belt press 7, preferably a heating is provided in order to obtain that the respective film 6 and/of 18 and/or the surface of the substrate is sufficiently heated in order to come to a consolidation by fusing. This heating may
30 be performed by making use, at the entry of the belt press 7, of a heated roller, more particularly a deflection roller 32. However, in the chamber 15 preferably a cooled fluid is applied, for example, cooled air, in order to obtain in this manner a consolidation by stiffening after fusion.

35 According to an alternative, which may or may not be combined with the heating at the entry of the belt press 7, various temperatures can be maintained in the chamber 15, or the chamber may also be subdivided into segments in which

different temperatures are prevailing. For example, on the run-in side a high temperature may be maintained in order to promote fusing, whereas on the exit side cold air can be provided.

5 Finally, it is noted that in particular in respect to the effect of the strewing process, on the one hand, and in respect to the realization of impressions with an adjustable roller, on the other hand, all information of the following patent applications has to be understood as being incorporated in the present application by reference:

WO 2013/179261

10 BE 2014/0517

PCT/IB2014/058464

In figure 2, a variant is represented with the particularity that the reinforcement material, and in particular the reinforcement layer, such as the glass fiber fleece
15 12, is brought into contact with a plastisol, this in order to obtain a finally better consolidation and adherence among the various layers and to minimize the risk of a later delamination. In the example of figure 2, the plastisol is provided on the reinforcement layer, such as the glass fiber fleece 12, by means of a schematically represented device 34, whereby this penetrates in and through the glass fiber
20 fleece and reaches the relatively rough surface of the lowermost strewn layer. In figure 2 is also shown that a second layer of starting material 4 is strewn here over. By providing for that the plastisol is gelled, a consolidated whole is obtained with a good mutual adherence. For gelling the plastisol 33, of course the necessary heat has to be supplied. In the represented example, this is realized by means of a
25 heating device 35 installed between the device 34 and the second strewing device. It is noted that the heating may also take place at other locations, for example, downstream of the second strewing device, whether or not in the press portion 9. It is noted that the plastisol possibly may also be supplied to the reinforcement layer 12 before this latter is brought into contact with the strewn starting material.

30

According to a not represented embodiment, after the application of the reinforcement layer and the plastisol no additional starting material is strewn thereon, such that the plastisol forms the upper layer for the further process. In such case, it is even not excluded to add the reinforcement layer and the plastisol
35 only after the press portion 9 and subsequently guiding or not guiding it through an own press portion.

It is noted that the herein above-mentioned possibilities for using a plastisol as such form independent aspects of the present invention, in particular where and how the plastisol is applied in combination with the strewing. These independent aspects thus may be applied whether or not in combination with the further
5 downstream applied steps which were described herein above. Thus, combinations with other, subsequent production techniques are not excluded.

Finally, it is also noted that it is not excluded to work, instead of with a device 30 for printing the film 6 which is installed at a location before this film 6 is brought into
10 contact with the substrate, with a device which provides a print after the film 6 is laminated onto the substrate, and preferably prior to providing possible prints.

According to a deviating independent aspect of the invention, one or more of the herein above-described production steps, which take place during said strewing,
15 are combined with the application of a print directly on the formed material web, irrespective whether a film 6 is applied or not. As an example, this means that, for example, the film 6 is not provided and there is also no device 5, however, that at that location a printing device for providing a print is present.

20 It is also noted that, when a transparent lacquer layer is provided, this latter can be provided before or after providing the impressions on the final surface.

The present invention is in no way limited to the herein above-described embodiments, on the contrary may such method and installation be realized
25 according to various variants without exceeding the scope of the present invention. Moreover, the panels, instead as floor panels, may also be made as wall panels or ceiling panels or even as furniture panels. Alternatively, the invention thus also relates to the same method as described herein above, however, then applied for the production of other panels than floor panels.

Claims.

1.- Method for manufacturing a floor covering product, wherein this method
5 comprises at least a first step of forming a single- or multi-layered substrate (3) by
consolidating synthetic material-based starting material (4), as well as comprises a
second step after the first step, which preferably is performed in line with the first
step, wherein at least one continuous film (6) is laminated onto the substrate,
characterized in that said laminating is performed by means of a belt press (7).

10

2.- Method according to claim 1, characterized in that the forming of the
substrate (3) is performed by means of a strewing process, wherein the synthetic
material-based starting material (4) is strewn as a granulate and subsequently is
consolidated in a press device (9).

15

3.- Method according to claim 2, characterized in that the strewn granulate is
consolidated by means of a continuous press, more particularly a belt press, and in
particular a double belt press (10).

20

4.- Method according to claim 1, characterized in that the forming of the
substrate is performed by means of extrusion, preferably an extrusion wherein the
synthetic material-based material, more particularly starting material, is extruded in
layer shape, or by means of a comparable process, wherein possibly a plurality of
layers are thermally laminated on top of each other.

25

5.- Method according to any of the preceding claims, characterized in that the
step of forming the substrate (3) shows one or more of the following
characteristics:

- that in the starting material, one or more other materials than synthetic
30 materials are incorporated, such as additives and/or fillers, amongst others,
chalk;

- that reinforcement material, more particularly fibers, are included in the
substrate, preferably in the form of one or more local layers in the form of a
fiber mat, non-woven or fabric, for example, on the basis of glass fiber,
35 such as a glass fiber fleece, cloth or net.

- 6.- Method according to any of the preceding claims, characterized in that said laminating of the continuous film (6) in said second step is performed by means of a double belt press (7).
- 5 7.- Method according to any of the preceding claims, characterized in that said laminating of the continuous film (6) in said second step is performed by means of a belt press (7) which is made as an isobaric press.
- 8.- Method according to any of the preceding claims, characterized in that said
10 laminating of the continuous film (6) in the belt press in said second step is performed by means of a fluid pressure which is exerted on a surface of a belt (14) of the belt press, more particularly in a zone along which this belt is moving.
- 9.- Method according to claim 8, characterized in that in said second step a
15 double belt press (7) is applied, wherein the substrate and the continuous film are moved along between the two belts (14-17) of the double belt press, wherein the fluid pressure is exerted on the belt which is located on the side of the continuous film, whereas the other belt acts as a counter support.
- 20 10.- Method according to claim 7, characterized in that during laminating, in said second step, instead of said belt press use is made of another press, which press, however, is an isobaric press, more particularly is a press which presses the film directly or indirectly with a uniform fluid pressure over a surface of the substrate onto this latter.
- 25 11.- Method according to any of the claims 7 to 10, characterized in that for creating the pressure in the press, use is made of a gaseous fluid, more particularly air, or according to an alternative, of a liquid, for example, oil.
- 30 12.- Method according to any of the preceding claims, characterized in that laminating the film (6) on the substrate is performed by fusing.
- 13.- Method according to claim 12, characterized in that for the purpose of providing a fusion, the substrate and/or the film to be provided thereon by
35 lamination are brought to a suitable temperature.

- 14.- Method according to claim 13, characterized in that said temperature is realized by means of or at least in part by means of one or more of the following possibilities:
- by applying heat which is present in the substrate, originating from said first step;
 - by supplying heat to the substrate and/or to the continuous film, between the first and second step or during the second step.
- 15.- Method according to claim 14, characterized in that during the second step heat is supplied via a heated roller placed at the starting point of the belt press, preferably a deflection roller (32) of a belt of the press, which comes into contact with the continuous film.
- 16.- Method according to any of the preceding claims, characterized in that towards the end of laminating, a cooling is provided for consolidating the assembly of substrate and film.
- 17.- Method according to claim 16, characterized in that for laminating, use is made of a fluid pressure which is exerted directly or indirectly on a surface of a belt of the belt press, wherein the cooling is performed via this fluid.
- 18.- Method according to any of the preceding claims, characterized in that said continuous film (6) is a decor film and more particularly a film which is provided with a print.
- 19.- Method according to claim 18, characterized in that the film (6) forming the decor layer is printed directly, thus, during the manufacturing process, however, prior to laminating, preferably by means of a digital printer or printing unit (30).
- 20.- Method according to any of the preceding claims, characterized in that impressions are provided in the upper side of the floor covering product, more particularly in one and the same continuous process, preferably after laminating the continuous film onto the substrate.
- 21.- Method according to claim 20, characterized in that the floor covering product comprises a printed decor and that the impressions are realized as so-called "in register" with the decor.

22.- Method according to claim 21, characterized in that the impressions are applied by means of a, whether or not multi-piece, roller (21), which is provided with a relief on its surface.

5

23.- Method according to claim 22, characterized in that a roller is applied with, seen along the circumference, at least two segments (22-23), which each are provided with a relief, wherein in circumferential direction the distance (A1-A2) between at least two of these segments (22-23) is adjustable in order to change the so-called "repeat" with which the impressions are realized, wherein this "repeat" is adjusted and altered in function of the position of the decor.

10

24.- Method according to claim 22 or 23, characterized in that the substrate and said continuous film (6), whether or not together with still other layers, form a material web, and that this material web (27) is bent around said roller, such that the cooperation between the relief and the material web takes place at least over an arc-shaped part.

15

25.- Method according to claim 24, characterized in that the material, which is moving along with the roller, of the material web (27) is maintained in contact with the roller at least for 3 seconds, and still better for at least 5 seconds.

20

26.- Method according to claim 24 or 25, characterized in that the material web is supplied to the roller (21) in a heated condition and that the roller (21) is cooled.

25

27.- Method according to any of the preceding claims, characterized in that said continuous film (6) is a decor layer and that this film, prior to laminating, is subjected to controlled stretching in order to stretch the decor to a greater or lesser extent, in the width and/or length, such that the decor is adjusted in function of the desired final result.

30

28.- Method according to any of the preceding claims, characterized in that the floor covering product is provided with a translucent wear layer.

35

29.- Method according to any of the preceding claims, characterized in that the substrate and said continuous film, whether or not together with still other layers,

form a material web (27) and that this material web is cut to floor panels, more particularly to rectangular oblong or square panels or tiles.

30.- Method according to claim 29, characterized in that the floor panels are
5 formed free from coupling parts at their edges, wherein the floor panels are of the type intended for being installed according to the "loose lay" principle, or for being installed by means of gluing to the underlying surface.

31.- Method according to claim 29, characterized in that the floor panels are
10 provided with coupling parts at their edges, whereby a plurality of such panels can be coupled to each other at their edges in a mechanical manner in order to thereby provide for a locking preferably horizontally as well as vertically.

32.- Method according to any of the claims 29 to 31, characterized in that it is
15 applied for the production of so-called LVT tiles or comparable floor panels.

33.- Method according to any of the preceding claims, characterized in that
instead of using said continuous film (6), use is made of successive film sheets which are laminated on the continuously formed substrate.

20

34.- Method according to any of the preceding claims, characterized in that the substrate shows one or more of the following characteristics:

- the material of the substrate contains a thermoplastic;
- the material of the substrate contains a supple thermoplastic, more
25 particularly a thermoplastic which is provided with a plasticizer;
- the material of the substrate is based on any of the following materials: polyvinyl chloride (PVC), polypropylene (PP), polyethylene (PET) or polyurethane (PUR);
- the material of the substrate contains one or more filler materials, for
30 example, chalk;
- the material of the substrate, either across the entire thickness thereof, or across only a portion of the thickness thereof, substantially consists of a composite of synthetic material and wood particles, and more particularly WPC (Wood Plastic Composite), wherein for the synthetic material
35 preferably use is made of any of the herein above-mentioned synthetic materials;

- the substrate consists of at least two layers, namely, a layer such as described in the preceding paragraph, and a layer which is free or substantially free from wood particles and substantially is based on synthetic material;
- 5 - the substrate contains a reinforcement layer, such as a glass fiber fleece or the like.

35.- Method according to any of the preceding claims, characterized in that the continuous film shows one or more of the following characteristics:

- 10 - it relates to a thermoplastic synthetic material film;
- it relates to a PVC film, PU film, PP film, or PET film;
- it relates to an oriented polypropylene film;
- it relates to a hard PVC film, namely, a film on the basis of PVC without plasticizer or with an amount of plasticizer of less than 5 percent by weight.

15

36.- Method according to any of the preceding claims, characterized in that the substrate, starting from its manufacture up to the forming of the final floor covering product, is handled in a flat state, or, during bending, is subjected exclusively to bending having a radius of more than 40 cm.

20

37.- Installation for manufacturing a floor covering product, more particularly for realizing the aforementioned method, characterized in that it consists at least of a device (2) for forming a single- or multi-layered substrate (3) by consolidation of synthetic material-based starting material (4), as well as a device (5) connected thereto for laminating at least one preferably continuous film on the substrate, wherein this latter device makes use of a belt press (7).

25

38.- Installation according to claim 37, characterized in that use is made of a press with features as described in any of the claims 6 to 9.

30

39.- Installation according to claim 37 or 38, characterized in that it also comprises a device (19) for forming impressions in order to provide the floor covering product with a relief on its surface, wherein for this device preferably use is made of a roller which provides for the possibilities according to any of the claims 21 to 26.

35

40.- Installation according to any of the claims 37 to 39, characterized in that it comprises a printing device, preferably a digital printer, by which a decor is printed on the continuous film, preferably while this film is supplied to the device for lamination.

5

41.- Installation according to any of the claims 37 to 40, characterized in that it comprises additional devices and/or comprises additional provisions for effecting one or more operations, as described in the claims 1 to 36.

10 42.- Method for manufacturing a floor covering product, wherein this method comprises at least a first step for forming a single- or multi-layered substrate by consolidating synthetic material-based starting material, as well as comprises a second step after the first step, which preferably is performed in line with the first step, wherein at least one continuous film is laminated on the substrate, and also
15 comprises a third step, wherein impressions are formed in the surface, with the characteristic:

- that the forming of the substrate is performed by means of a strewing process, wherein the synthetic material-based starting material is strewn as a granulate and subsequently is consolidated in a press device (9); and
- 20 - that the impressions are provided by means of a roller (21), which is provided with a relief on its surface, wherein for this roller a roller is applied with, seen along the circumference, at least two segments, which each are provided with a relief, wherein in circumferential direction the distance between at least two of these segments is adjustable in order to change the
25 so-called "repeat" with which the impressions are realized, wherein this "repeat" is adjusted and altered in function of the position of an applied decor.

30 43.- Floor covering product, characterized in that it is manufactured according to any of the claims 1 to 36 or 42.

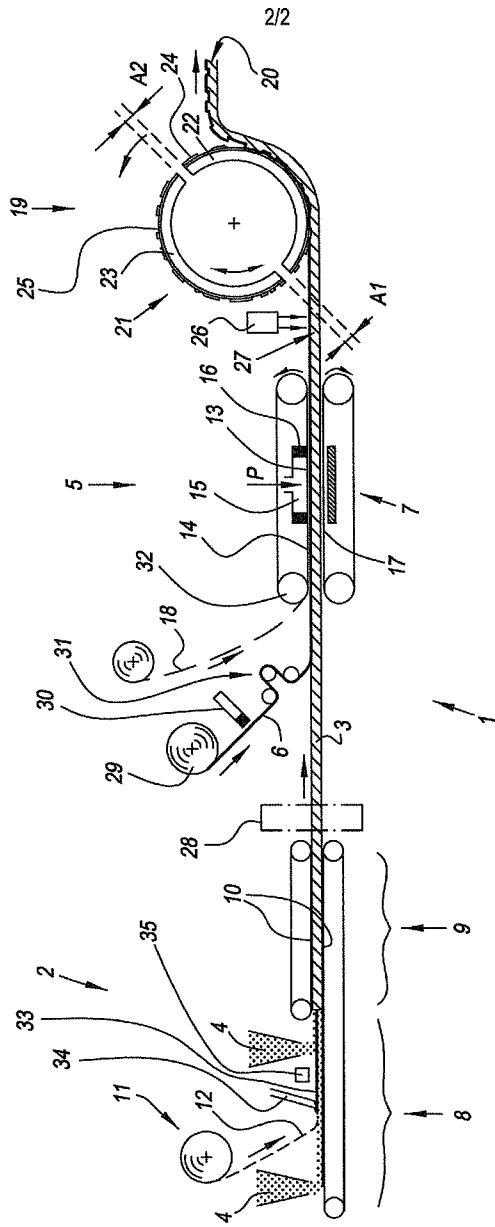

Fig. 2

INTERNATIONAL SEARCH REPORT

International application No
PCT/IB2015/055826

A. CLASSIFICATION OF SUBJECT MATTER					
INV.	B32B21/08	B32B27/08	B32B27/30	B32B27/32	B32B27/36
	B32B37/04	E04F13/18	B32B37/14	B32B37/10	B32B37/15
	B32B38/06	B32B38/00	B32B37/24	E04F15/10	B44B5/00

According to International Patent Classification (IPC) or to both national classification and IPC

B. FIELDS SEARCHED
Minimum documentation searched (classification system followed by classification symbols) B32B E04F B44B B44C

Documentation searched other than minimum documentation to the extent that such documents are included in the fields searched

Electronic data base consulted during the international search (name of data base and, where practicable, search terms used) EPO-Internal, WPI Data
--

C. DOCUMENTS CONSIDERED TO BE RELEVANT

Category*	Citation of document, with indication, where appropriate, of the relevant passages	Relevant to claim No.
X	<p>WO 2012/001109 A1 (SPANOLUX N V DIV BALTERIO [BE]; VERMEULEN BRUNO PAUL LOUIS [BE]) 5 January 2012 (2012-01-05)</p> <p>page 1, line 5 - page 2, line 22 page 4, line 6 - line 25 page 5, line 7 - line 15 page 11, line 17 - line 35 page 12, line 3 - page 13, line 37; claims 1-24; figures 2-5</p> <p style="text-align: center;">----- -/--</p>	<p>1-3,5,6, 9,12,14, 16, 18-20, 22, 28-41,43</p>

Further documents are listed in the continuation of Box C. See patent family annex.

* Special categories of cited documents :

<p>"A" document defining the general state of the art which is not considered to be of particular relevance</p> <p>"E" earlier application or patent but published on or after the international filing date</p> <p>"L" document which may throw doubts on priority claim(s) or which is cited to establish the publication date of another citation or other special reason (as specified)</p> <p>"O" document referring to an oral disclosure, use, exhibition or other means</p> <p>"P" document published prior to the international filing date but later than the priority date claimed</p>	<p>"T" later document published after the international filing date or priority date and not in conflict with the application but cited to understand the principle or theory underlying the invention</p> <p>"X" document of particular relevance; the claimed invention cannot be considered novel or cannot be considered to involve an inventive step when the document is taken alone</p> <p>"Y" document of particular relevance; the claimed invention cannot be considered to involve an inventive step when the document is combined with one or more other such documents, such combination being obvious to a person skilled in the art</p> <p>"&" document member of the same patent family</p>
---	---

Date of the actual completion of the international search 5 November 2015	Date of mailing of the international search report 17/11/2015
---	---

Name and mailing address of the ISA/ European Patent Office, P.B. 5818 Patentlaan 2 NL - 2280 HV Rijswijk Tel. (+31-70) 340-2040, Fax: (+31-70) 340-3016	Authorized officer Espen, Josée
--	---

INTERNATIONAL SEARCH REPORT

International application No
PCT/IB2015/055826

C(Continuation). DOCUMENTS CONSIDERED TO BE RELEVANT		
Category*	Citation of document, with indication, where appropriate, of the relevant passages	Relevant to claim No.
X	WO 2013/179260 A1 (UNILIN BVBA [BE]) 5 December 2013 (2013-12-05) page 4, line 27 - page 5, line 17 page 7 - page 8 page 9, line 11 - page 10 page 12, paragraph 3 page 13, line 7 - line 17 page 15, line 3 - line 20; claims 1-15; figures 1-3 -----	1-19, 28-32, 34,43
X,P	WO 2014/115086 A2 (UNILIN BVBA [BE]) 31 July 2014 (2014-07-31) cited in the application	43
Y,P	page 1 page 2, line 11 - page 3, line 3 page 5, line 22 - line 26 page 18, line 26 - line 30; claims 1-4,9-14; figures 11-16 -----	20-27,42
Y	US 2010/300609 A1 (CALDAS VICTOR [CA] ET AL) 2 December 2010 (2010-12-02) claims 34,35,47,48 -----	29-32
Y	US 2005/166513 A1 (VANDERHOEF JOHN P [US]) 4 August 2005 (2005-08-04) figures 1-5 -----	29-32
Y	WO 97/01442 A1 (KURZ LEONHARD FA [DE]; KOENIG & BAUER ALBERT AG [DE]; MITSAM REINWALD) 16 January 1997 (1997-01-16) the whole document -----	20-27,42
Y	DE 10 2011 012735 A1 (SAECHSISCHE WALZENGRVUR GMBH [DE]) 30 August 2012 (2012-08-30) the whole document -----	20-27,42
A	US 2013/147090 A1 (SCHROMM HANS-KURT [DE] ET AL) 13 June 2013 (2013-06-13) cited in the application the whole document -----	3,7-11, 15

INTERNATIONAL SEARCH REPORT

Information on patent family members

International application No

PCT/IB2015/055826

Patent document cited in search report	Publication date	Patent family member(s)	Publication date		
WO 2012001109 A1	05-01-2012	CA 2804100 A1	05-01-2012		
		CN 103153608 A	12-06-2013		
		EP 2588310 A1	08-05-2013		
		RU 2013101801 A	10-08-2014		
		US 2014147641 A1	29-05-2014		
		WO 2012001109 A1	05-01-2012		
		WO 2013179260 A1	05-12-2013	BE 1020722 A3	01-04-2014
CN 104428475 A	18-03-2015				
CN 104619936 A	13-05-2015				
EP 2861808 A1	22-04-2015				
EP 2861809 A1	22-04-2015				
KR 20150022915 A	04-03-2015				
KR 20150022916 A	04-03-2015				
US 2015121793 A1	07-05-2015				
US 2015167319 A1	18-06-2015				
WO 2013179260 A1	05-12-2013				
WO 2013179261 A1	05-12-2013				
WO 2014115086 A2	31-07-2014	EP 2948318 A2	02-12-2015		
		WO 2014115086 A2	31-07-2014		
US 2010300609 A1	02-12-2010	CA 2761766 A1	02-12-2010		
		EP 2435249 A1	04-04-2012		
		ES 2439649 T3	24-01-2014		
		RU 2011149753 A	10-07-2013		
		UA 104317 C2	27-01-2014		
		US 2010300609 A1	02-12-2010		
		US 2014339725 A1	20-11-2014		
		WO 2010136543 A1	02-12-2010		
US 2005166513 A1	04-08-2005	US 2005166513 A1	04-08-2005		
		US 2008209840 A1	04-09-2008		
		US 2011061330 A1	17-03-2011		
WO 9701442 A1	16-01-1997	AT 187927 T	15-01-2000		
		AU 693680 B2	02-07-1998		
		BG 62799 B1	31-08-2000		
		BR 9608948 A	02-03-1999		
		CA 2224815 A1	16-01-1997		
		CN 1189128 A	29-07-1998		
		CZ 9704154 A3	12-08-1998		
		DE 19523441 A1	02-01-1997		
		DE 19680498 D2	23-07-1998		
		DE 59603987 D1	27-01-2000		
		EP 0835181 A1	15-04-1998		
		ES 2140836 T3	01-03-2000		
		JP 3095081 B2	03-10-2000		
		JP H11509144 A	17-08-1999		
		NO 975825 A	16-12-1997		
		NZ 304826 A	25-02-1999		
		US 5937759 A	17-08-1999		
		WO 9701442 A1	16-01-1997		
		DE 102011012735 A1	30-08-2012	NONE	
		US 2013147090 A1	13-06-2013	CN 103052482 A	17-04-2013
DE 102010033578 A1	09-02-2012				

INTERNATIONAL SEARCH REPORT

Information on patent family members

International application No

PCT/IB2015/055826

Patent document cited in search report	Publication date	Patent family member(s)	Publication date
		EA 201390174 A1	30-07-2013
		EP 2601028 A1	12-06-2013
		US 2013147090 A1	13-06-2013
		WO 2012016916 A1	09-02-2012
<hr/>			