

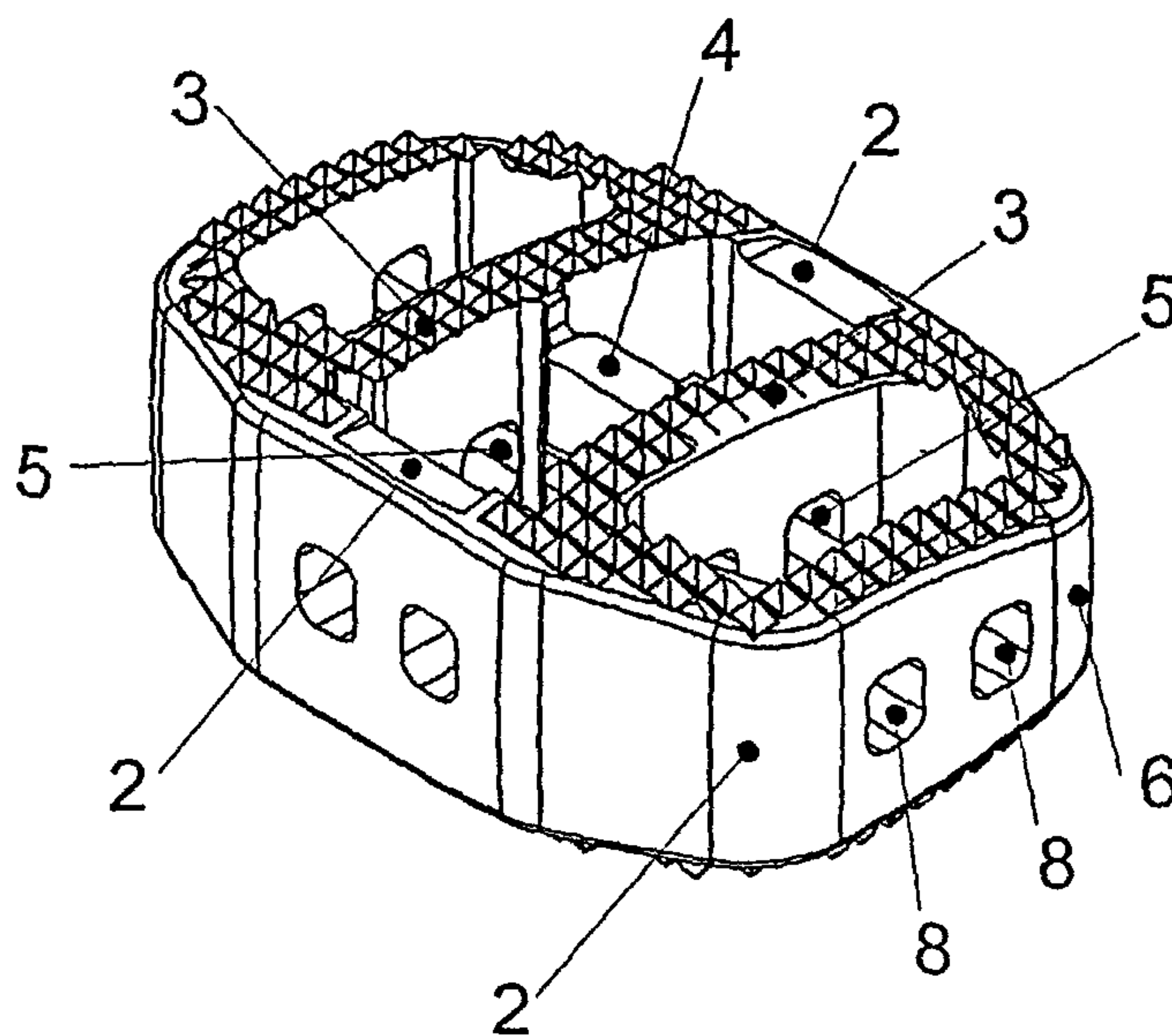

(86) Date de dépôt PCT/PCT Filing Date: 2001/01/30
 (87) Date publication PCT/PCT Publication Date: 2002/08/08
 (85) Entrée phase nationale/National Entry: 2003/07/29
 (86) N° demande PCT/PCT Application No.: CH 2001/000069
 (87) N° publication PCT/PCT Publication No.: 2002/060356

(51) Cl.Int.⁷/Int.Cl.⁷ A61F 2/44
 (71) Demandeur/Applicant:
SYNTHES (U.S.A.), US
 (72) Inventeurs/Inventors:
MATHYS, ROBERT JR., CH;
LECHMANN, BEAT, CH;
GASSER, BEAT, CH
 (74) Agent: OSLER, HOSKIN & HARCOURT LLP

(54) Titre : **IMPLANT OSSEUX, EN PARTICULIER IMPLANT INTERVERTEBRAL**
 (54) Title: **BONE IMPLANT, IN PARTICULAR, AN INTER-VERTEBRAL IMPLANT**



(57) **Abrégé/Abstract:**

The inter-vertebral implant is made from a radiation-transparent material and embodied as an annular hollow body (1). Said implant comprises a sleeve (6) in the form of a hollow cylindrical section, comprising a front (9), a rear (10) and two lateral sections (11) and defines a cylindrical axis (7). The hollow body (1) is divided by two intermediate walls (3), running essentially parallel to the cylinder axis (7) and connecting the front section (9) with the rear section (10) of the sleeve. The surface (2) of the bone implant comprises a surface roughness of at least 2 µm. This surface roughness permits the newly growing bone a better fixation to the implant, in other words a better bone integration.

(12) NACH DEM VERTRAG ÜBER DIE INTERNATIONALE ZUSAMMENARBEIT AUF DEM GEBIET DES PATENTWESENS (PCT) VERÖFFENTLICHTE INTERNATIONALE ANMELDUNG

(19) Weltorganisation für geistiges Eigentum
Internationales Büro(43) Internationales Veröffentlichungsdatum
8. August 2002 (08.08.2002)

PCT

(10) Internationale Veröffentlichungsnummer
WO 02/060356 A1

- (51) Internationale Patentklassifikation⁷: A61F 2/44 (CH). LECHMANN, Beat [CH/CH]; Grenchenstrasse 29A, CH-2544 Bettlach (CH). GASSER, Beat [CH/CH]; Jurastrasse 27, CH-3063 Ittigen (CH).
- (21) Internationales Aktenzeichen: PCT/CH01/00069
- (22) Internationales Anmeldedatum: 30. Januar 2001 (30.01.2001) (74) Anwalt: LUSUARDI, Werther; Dr. Lusuardi AG, Kreuzbühlstrasse 8, CH-8008 Zürich (CH).
- (25) Einreichungssprache: Deutsch (81) Bestimmungsstaaten (*national*): AE, AL, AM, AT, AU, AZ, BA, BB, BG, BR, BY, CA, CH, CN, CR, CU, CZ, DE, DK, DM, EE, ES, FI, GB, GD, GE, GH, GM, HR, HU, ID, IL, IN, IS, JP, KE, KG, KP, KR, KZ, LC, LK, LR, LS, LT, LU, LV, MA, MD, MG, MK, MN, MW, MX, NO, NZ, PL, PT, RO, RU, SD, SE, SG, SI, SK, SL, TJ, TM, TR, TT, TZ, UA, UG, US, UZ, VN, YU, ZA, ZW.
- (26) Veröffentlichungssprache: Deutsch (84) Bestimmungsstaaten (*regional*): ARIPO-Patent (GH, GM, KE, LS, MW, MZ, SD, SL, SZ, TZ, UG, ZW), eurasisches Patent (AM, AZ, BY, KG, KZ, MD, RU, TJ, TM), europäisches Patent (AT, BE, CH, CY, DE, DK, ES, FI, FR, GB, GR, IE, IT, LU, MC, NL, PT, SE, TR), OAPI-Patent (BF, BJ, CF, CG, CI, CM, GA, GN, GW, ML, MR, NE, SN, TD, TG).
- (71) Anmelder (*für alle Bestimmungsstaaten mit Ausnahme von CA, US*): SYNTHES AG CHUR [CH/CH]; Grabenstrasse 15, CH-7002 Chur (CH).
- (71) Anmelder (*nur für CA*): SYNTHES (U.S.A.) [US/US]; 1690 Russell Road, P.O. Box 1766, Paoli, PA 19301-1222 (US).
- (72) Erfinder; und (75) Erfinder/Anmelder (*nur für US*): MATHYS, Robert, Jr. [CH/CH]; Chrüzliacherstrasse 11, CH-2544 Bettlach

[Fortsetzung auf der nächsten Seite]

(54) Title: BONE IMPLANT, IN PARTICULAR, AN INTER-VERTEBRAL IMPLANT

(54) Bezeichnung: KNOCHENIMPLANTAT, INSBESONDERE ZWISCHENWIRBELIMPLANTAT

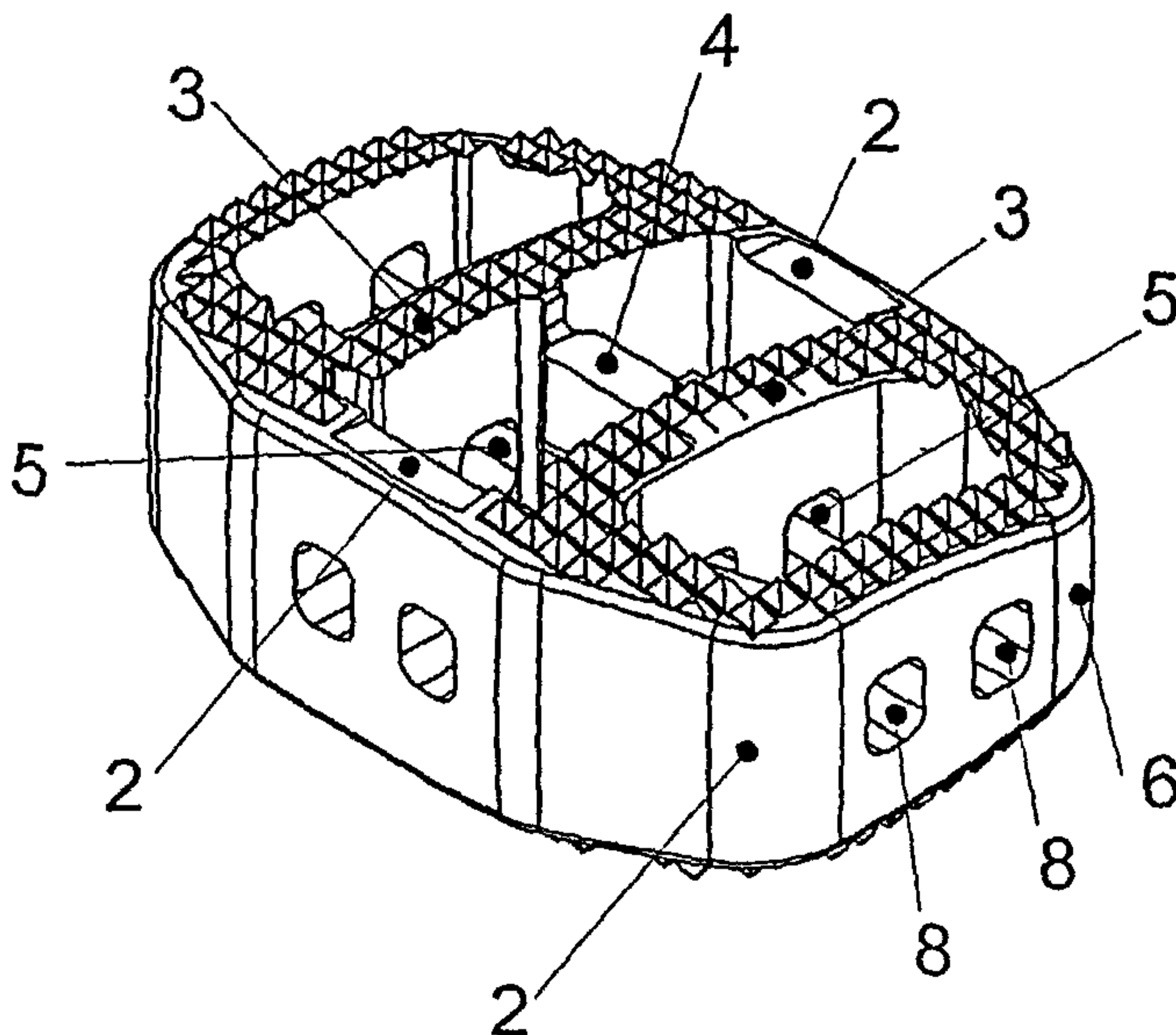

(57) Abstract: The inter-vertebral implant is made from a radiation-transparent material and embodied as an annular hollow body (1). Said implant comprises a sleeve (6) in the form of a hollow cylindrical section, comprising a front (9), a rear (10) and two lateral sections (11) and defines a cylindrical axis (7). The hollow body (1) is divided by two intermediate walls (3), running essentially parallel to the cylinder axis (7) and connecting the front section (9) with the rear section (10) of the sleeve. The surface (2) of the bone implant comprises a surface roughness of at least 2 μm . This surface roughness permits the newly growing bone a better fixation to the implant, in other words a better bone integration.

(57) Zusammenfassung: Das Zwischenwirbelimplantat besteht aus einem strahlendurchlässigen Material und ist als ringförmiger Hohlkörper (1) ausgebildet. Es besitzt einen hohlzylinderabschnittförmigen Mantel (6), der einen vorderen (9), einen hinteren

(10) und zwei seitliche Abschnitte (11) umfasst sowie eine Zylinderachse (7) definiert. Der Hohlkörper (1) ist durch zwei Zwischenwände (3) unterteilt, welche im wesentlichen parallel zur Zylinderachse (7) verlaufen und den vorderen Abschnitt (9) mit hinteren Abschnitt (10) des Mantels verbinden. Die Oberfläche (2) des Knochenimplantats weist eine Oberflächenrauigkeit von mindestens 2 μm auf. Diese Oberflächenrauigkeit erlaubt dem neu gewachsenen Knochen eine bessere Verankerung am Implantat, d.h. eine bessere Knochenintegration.

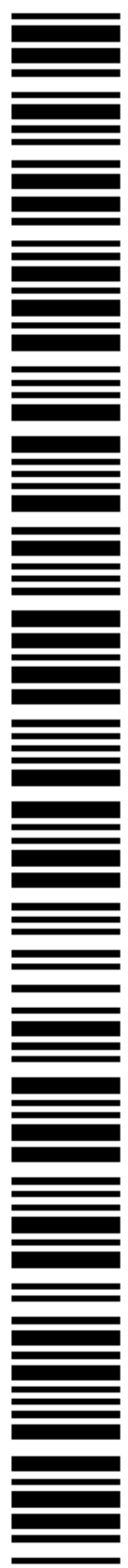

WO 02/060356 A1

WO 02/060356 A1



Veröffentlicht:

- mit internationalem Recherchenbericht
- mit geänderten Ansprüchen

Zur Erklärung der Zweibuchstaben-Codes und der anderen Abkürzungen wird auf die Erklärungen ("Guidance Notes on Codes and Abbreviations") am Anfang jeder regulären Ausgabe der PCT-Gazette verwiesen.

Bone Implant, in Particular, an Inter-vertebral Implant

The invention relates to a bone implant, in particular an inter-vertebral implant, according to the preamble of Claim 1, and to a method of manufacturing the bone implant according to the preamble of Claim 16.

Such a bone implant is known from French Patent Application 2 703 580 (Robert). The disadvantages of this known inter-vertebral implant are that

A) The smooth surface of the top and base areas of the implant, which are provided with coarse ribs and which come into contact with the endplates of the neighboring vertebral bodies, do not result in optimal growth of the bone tissue, and

B) When a filler is used in the hollow space in the implant, the filler can easily fall out on account of the smooth interior walls.

The preceding discussion of the prior art is provided solely to explain the background of the invention, and does not signify that the cited prior art at the time of this application, or its priority, has actually been published or made public.

The current invention provides a remedy. The object of the invention is to provide a bone implant, in particular an inter-vertebral implant, having an optimal surface structure for the growth of bone tissue.

The object of the invention is achieved by using a bone implant having the features of Claim 1, and a method having the features of Claim 16.

The surface roughness of at least 2 μm according to the invention affords the newly grown bone a better fixation to the implant, that is, a better bone integration.

In one preferred refinement of the invention, the hollow body is divided by at least two intermediate walls, the intermediate walls preferably being supported with respect to one another by a cross brace. These intermediate walls increase the support areas on the neighboring vertebral body endplates, thereby reducing the surface pressure and preventing the implant from sinking into the neighboring vertebral bodies. In addition, the hollow spaces in between allow growth with an osseous structure through the implant.

In another preferred refinement, the surface roughness is less than 10 μm . An excessive surface roughness weakens the remaining tips, which in turn can result in osteolysis, which would thus impair the arthrodesis.

In another preferred refinement, the intermediate walls are provided with perforations which preferably have a minimum area of 3.5 mm^2 . The perforations in the lateral walls serve to spatially fix the newly grown osseous structure and also act as an optional, primarily introduced filling compound.

In another preferred refinement, the lateral sections of the sleeve for the hollow body have perforations which preferably have a minimum area of 3.5 mm^2 . The perforations in the lateral sections of the sleeve serve to spatially fix the newly grown osseous structure and also to provide primary support for the implant during its insertion.

In another preferred refinement, the radiation-transparent material is selected from the following group: polyaryl ether ketone (PAEK), polyether imide (PEI), polyoxymethylene (POM), liquid crystalline polymer (LCP), polymethylpentene (PMP), polysulfone (PSU), polyethersulfone (PESU or PES), polyethylene terephthalate (PETP), polymethylmethacrylate (PMMA), and ultra-high molecular weight polyethylene (UHMW-PE).

All of these preferred materials are elastic, but have various mechanical properties such as elasticity (stiffness) in addition to strength. Compared to other polymers, they sometimes have favorable creep properties or exhibit low water absorption. It is thus possible to make an optimal selection, depending on the application requirements.

In another preferred refinement, the radiation-transparent material is fiber-reinforced, preferably with carbon fibers or PEEK fibers. Fiber reinforcement of the radiation-transparent material enhances the mechanical properties of stiffness in general, or to a targeted level.

In another preferred refinement, the ratio $V:v$ between total volume V of the bone implant and volume v of the hollow body is in the range of 1.9 to 2.3. It has been shown that this ratio combines the advantages of a mechanically stable implant with a maximum volume of newly grown osseous structure.

In another preferred refinement, the surface of the implant is provided at least partially with an X-ray-transparent coating or a thin coating which has no effect on the X-ray-transparency. The advantage of the X-ray-transparent coating makes it possible to observe the arthrodesis during growth. Since pure PEEK is characterized by excellent biocompatibility,
an

additional coating made of a suitable material enhances the mechanical properties and increases the interfaces between the newly grown bone and the implant. Metals are preferred as a suitable coating material (having a very small thickness which does not significantly impair the X-ray transparency). In particular, titanium, gold, platinum, or other appropriate implant metals are suitable.

In another preferred refinement, the coating is made of a ceramic material, preferably hydroxyapatite or tricalcium phosphate. Both ceramics, hydroxyapatite and tricalcium phosphate, which are suited for a coating have the advantage that they become fully integrated into the bone, or are even replaced by new, natural bone tissue.

In another preferred refinement, the hollow body is filled at least partially with a filler made of calcium phosphate, preferably hydroxyapatite or tricalcium phosphate, thereby achieving better, more trouble-free monitoring of the arthrodesis. The hollow body may also be filled with a filler made of calcium sulfate, demineralized bone, autologous bone, or coralline substances.

In another preferred refinement, the hollow body (1) is filled at least partially with an X-ray-opaque filler made of a resorbable, preferably porous

polymer. In order to design the filler to be X-ray-opaque, contrast medium is added to the polymer. For PLA a marker, for example, such as zirconium dioxide, may be added, and barium sulfate may be admixed with PEEK.

In another preferred refinement, the optional perforations in the implant are at least partially filled with the X-ray-opaque filler. The filler is thus prevented from falling out.

According to the method of manufacturing a bone implant according to the invention, the annular hollow body is manufactured by injection molding, hot forming, or hot pressing. The polymer is compressed in all form elements by hot forming, which is characterized particularly by better fatigue strength.

The invention and refinements of the invention are explained in greater detail with reference to the partial schematic illustration of an exemplary embodiment.

Figure 1 shows the perspective illustration of an inter-vertebral implant according to the invention;

Figure 2 shows a top view of the implant according to Figure 1;

Figure 3 shows a front view of the implant according to Figure 1; and

Figure 4 shows a side view of the implant according to Figure 1.

The inter-vertebral implant illustrated in Figures 1 through 4 is made of a radiation-transparent material (PEEK, which optionally may be reinforced with carbon fibers or glass fibers), which is designed in the injection molding process as an annular hollow body 1. The inter-vertebral implant comprises a sleeve 6 in the form of a hollow cylindrical section which has a front section 9, a rear section 10, and two lateral sections 11, and defines a cylindrical axis 7.

Hollow body 1 is divided into chambers by two intermediate walls 3 running essentially parallel to cylindrical axis 7 and connecting front section 9 with rear section 10 of the sleeve. Both intermediate walls 3 are supported with respect to one another by a cross brace 4. Intermediate walls 3 are provided with perforations 5 which have an area of approximately 10 mm^2 . Lateral sections 11 of sleeve 6 also have perforations 8, which have an area of approximately 10 mm^2 .

Surface 2 of the bone implant has a surface roughness of $6 \mu\text{m}$ and is provided with a thin, X-ray transparent coating made of gold.

8

The ratio $V:v$ between total volume V of the bone implant and volume v of hollow body 1 is approximately 2.1.

Hollow body 1 may be filled with X-ray-opaque filler made of hydroxyapatite, it being necessary to ensure that perforations 5;8 as well are preferably filled with the X-ray-opaque filler.

Claims

1. Bone implant, in particular an inter-vertebral implant, made of a radiation-transparent material and designed as an annular hollow body (1), [provided] with a sleeve (6) in the form of a hollow cylindrical section which comprises a front section (9), a rear section (10), and two lateral sections (11) and which defines a cylindrical axis (7),

characterized in that

A) the hollow body (1) being divided by at least two intermediate walls (3) running essentially parallel to the cylindrical axis (7) and connecting the front section (9) with the rear section (10) of the sleeve, and

B) the surface (2) of the bone implant has a surface roughness of at least 2 μm .
2. Bone implant according to Claim 1, characterized in that the intermediate walls (3), are supported with respect to one another by a cross brace (4).
3. Bone implant according to Claim 1 or 2, characterized in that the surface roughness is less than 10 μm .

5. Bone implant according to one of the Claims 1 to 4 characterized by the fact that the lateral sections (11) of the mantle (6) have perforations (8) that preferably have a minimum area of 3.5 mm².
6. Bone implant according to one of the Claims 1 to 5 characterized by the fact that the radiation-permeable material can be chosen from the following group: polyarylether ketone (PAEK), polytherimide (PEI), polyoxymethylene (POM), liquid-crystal polymer (LCP), polymethyl pentene (PMP), polysulfone (PSU), polyether sulfone (PESU or PES), polyethylene terephthalate (PETP), polymethyl methacrylate (PMMA) and ultra-high molecular polyethylene (UHMW-PE).
7. Bone implant according to one of the Claims 1 to 6 characterized by the fact that the radiation-permeable material is strengthened with fibers, preferably with carbon fibers, glass fibers or PEEK fibers.
8. Bone implant according to one of the Claims 1 to 7 characterized by the fact that the ratio $V : v$ between the total volume V of the bone implant and the volume v of the hollow body (1) ranges from 1.9 to 2.3.

9. Bone implant according to one of Claims 1 through 8, characterized in that the surface of the bone implant is provided at least partially with an X-ray-transparent coating or a thin coating which has little effect on the X-ray-transparency.
10. Bone implant according to Claim 9, characterized in that the coating is made of a metal, preferably titanium, gold, or platinum.
11. Bone implant according to Claim 9, characterized in that the coating is made of a ceramic material, preferably hydroxyapatite or tricalcium phosphate.
12. Bone implant according to one of Claims 1 through 11, characterized in that the hollow body (1) is filled at least partially with a filler made of calcium phosphate, preferably hydroxyapatite or tricalcium phosphate.
13. Bone implant according to one of Claims 1 through 11, characterized in that the hollow body (1) is filled at least partially with a filler made of calcium sulfate, demineralized bone, autologous bone, or coralline substances.

14. Bone implant according to one of Claims 1 through 11, characterized in that the hollow body (1) is filled at least partially with a filler made of a resorbable, preferably porous polymer.
15. Bone implant according to one of Claims 4 through 14, characterized in that the optional perforations (5;8) are at least partially filled with the X-ray-opaque filler.
16. Method of manufacturing a bone implant according to one of Claims 1 through 15, characterized in that the annular hollow body (1) is manufactured by injection molding, hot forming, or hot pressing.

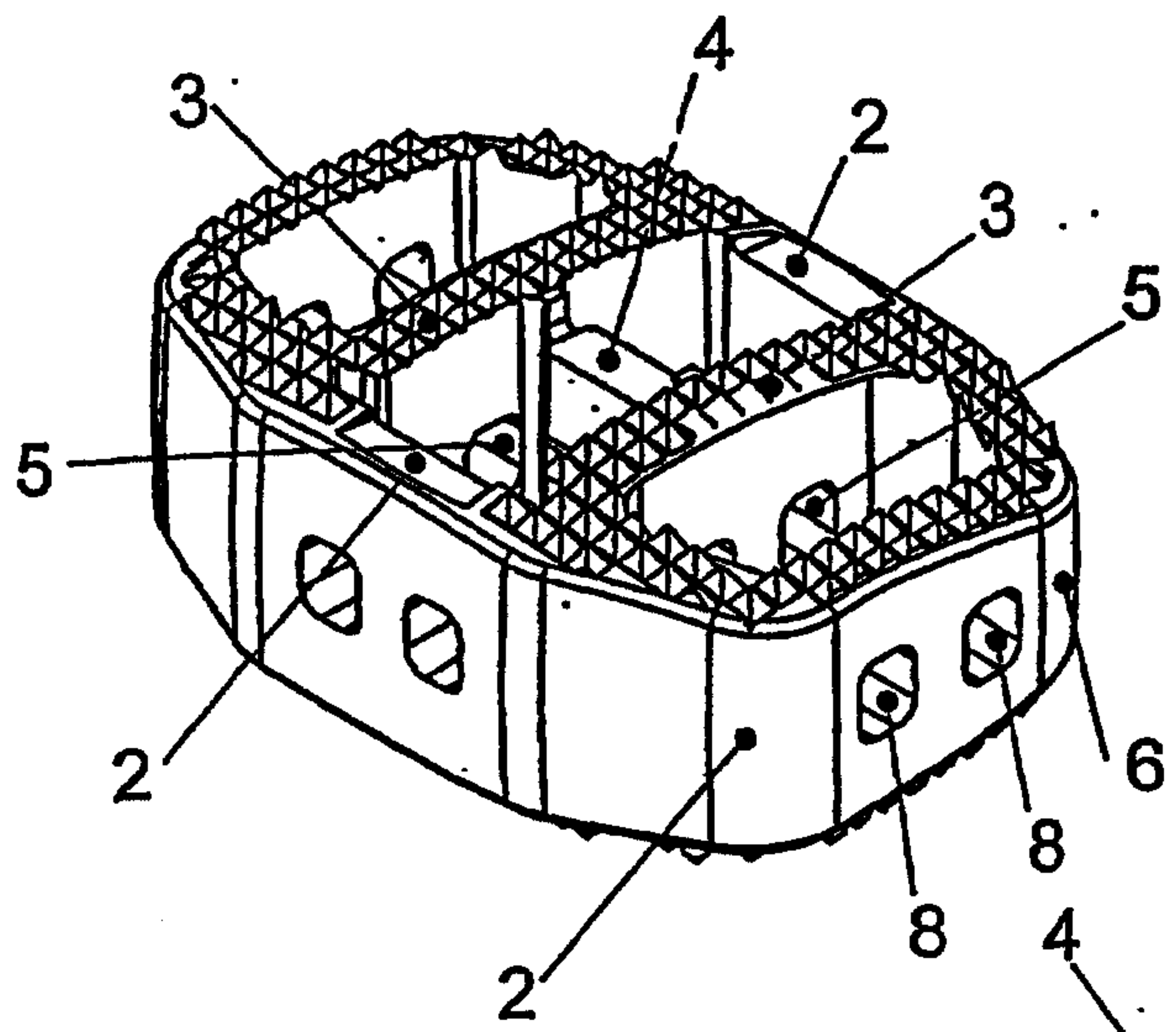

Fig. 1

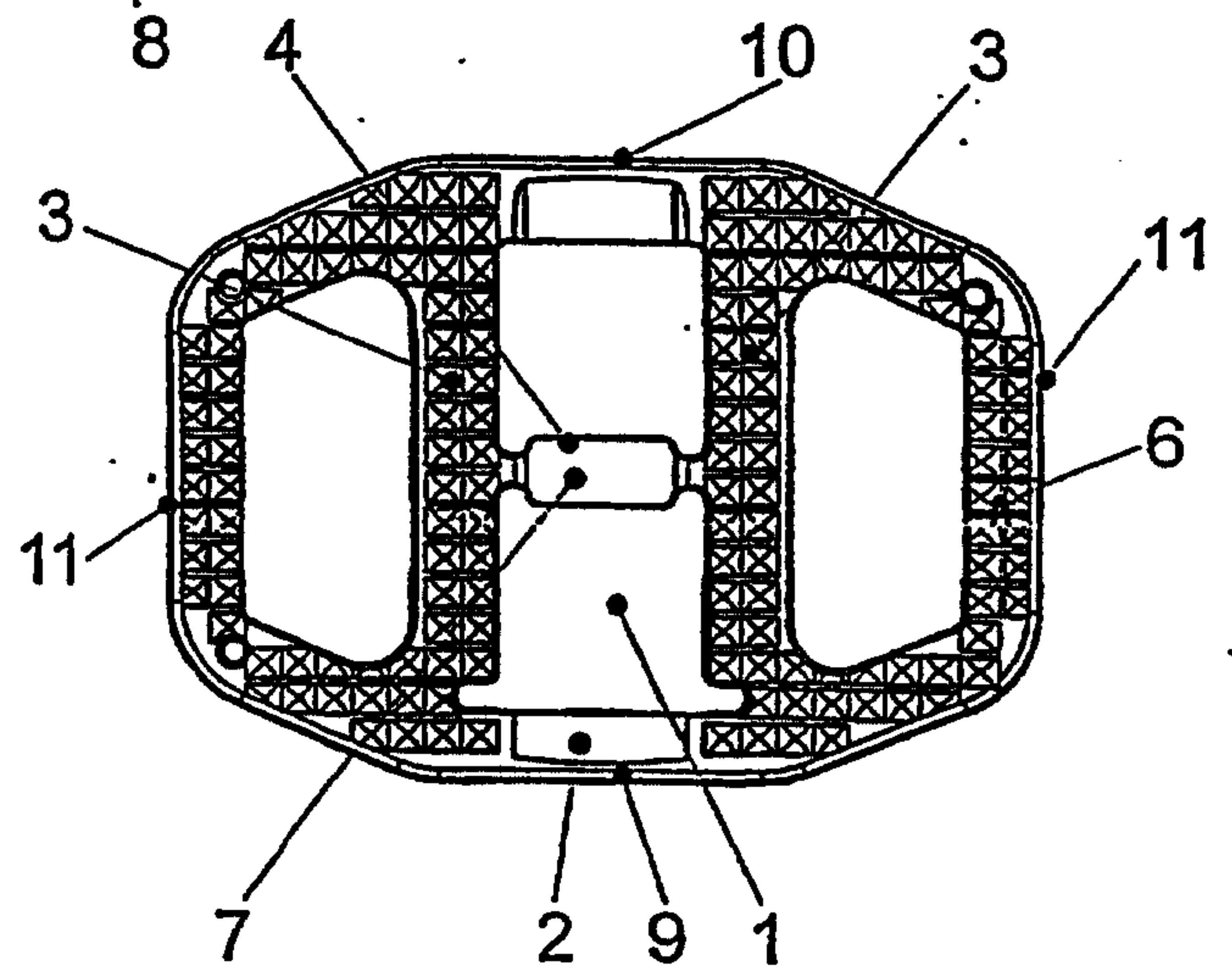

Fig. 2

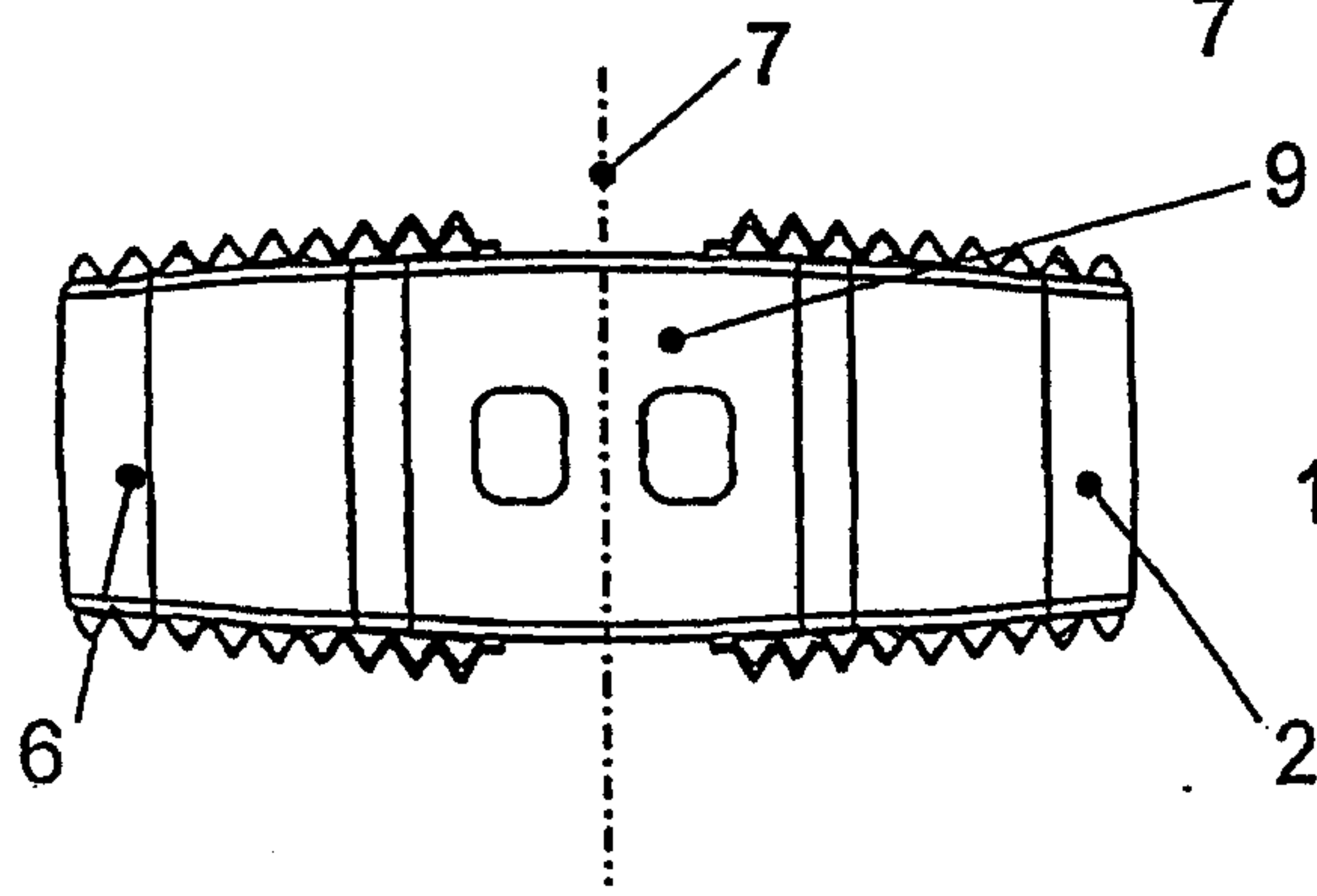

Fig. 3

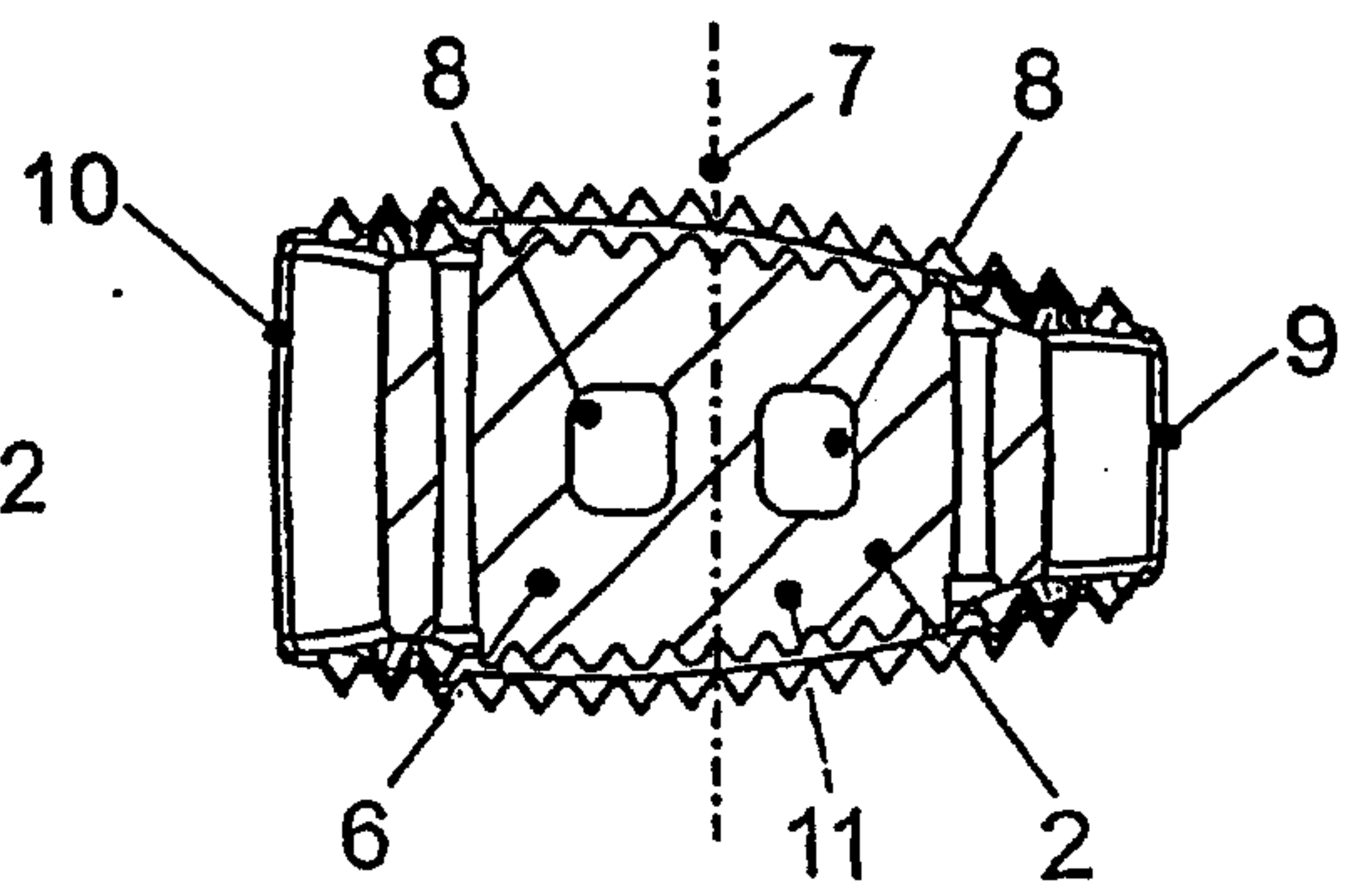

Fig. 4

ERSATZBLATT (REGEL 26)

