



US00D511783S

(12) **United States Design Patent** (10) **Patent No.:** **US D511,783 S**  
**Maruyama** (45) **Date of Patent:** **\*\* Nov. 22, 2005**

(54) **BASE CARRIER TRAVELER FOR A TRAVELING WORKING MACHINE**

(75) Inventor: **Katsuya Maruyama, Akashi (JP)**  
(73) Assignee: **Kobelco Construction Machinery Co., Ltd., Hiroshima (JP)**  
(\*\*) Term: **14 Years**

(21) Appl. No.: **29/223,210**  
(22) Filed: **Feb. 11, 2005**

**Related U.S. Application Data**

(62) Division of application No. 29/190,727, filed on Sep. 26, 2003.

**(30) Foreign Application Priority Data**

Mar. 26, 2003	(JP)	.....	2003-008226
Mar. 26, 2003	(JP)	.....	2003-008227
Mar. 26, 2003	(JP)	.....	2003-008228
Mar. 26, 2003	(JP)	.....	2003-008229
Mar. 26, 2003	(JP)	.....	2003-008230
Mar. 26, 2003	(JP)	.....	2003-008231
Mar. 26, 2003	(JP)	.....	2003-008232

(51) **LOC (8) Cl.** ..... **15-03**  
(52) **U.S. Cl.** ..... **D15/26**  
(58) **Field of Search** ..... **D15/10, 22-26;**  
175/52, 85, 22, 23, 28; 180/89.1, 89.12,  
900; 414/592, 618, 633, 680, 785, 694;  
172/456, 474

(56) **References Cited**  
**U.S. PATENT DOCUMENTS**

D221,573 S	8/1971	Ashton
D264,590 S	5/1982	Thomas
5,266,001 A	11/1993	Kanayama et al.
5,423,655 A	6/1995	Kanayama et al.
D366,489 S	1/1996	Brown
5,535,688 A	7/1996	Kaufman

*Primary Examiner*—Mitchell Siegel  
(74) *Attorney, Agent, or Firm*—Oblon, Spivak, McClelland, Maier & Neustadt, P.C.

(57) **CLAIM**

The ornamental design for a base carrier traveler for a traveling working machine, as shown and described.

**DESCRIPTION**

FIG. 1 is a front elevational view of a base carrier traveler for a traveling working machine;  
FIG. 2 is a front elevational view thereof;  
FIG. 3 is a left side elevational view thereof;  
FIG. 4 is a right side elevational view thereof;  
FIG. 5 is a top plan view thereof;  
FIG. 6 is a bottom plan view thereof;  
FIG. 7 is a top, rear and left side perspective view thereof; and,  
FIG. 8 is an enlarged end view taken along line A—A of FIG. 1 with the internal mechanisms thereof omitted.  
The phantom lines shown form no part of the claimed invention.

**1 Claim, 3 Drawing Sheets**

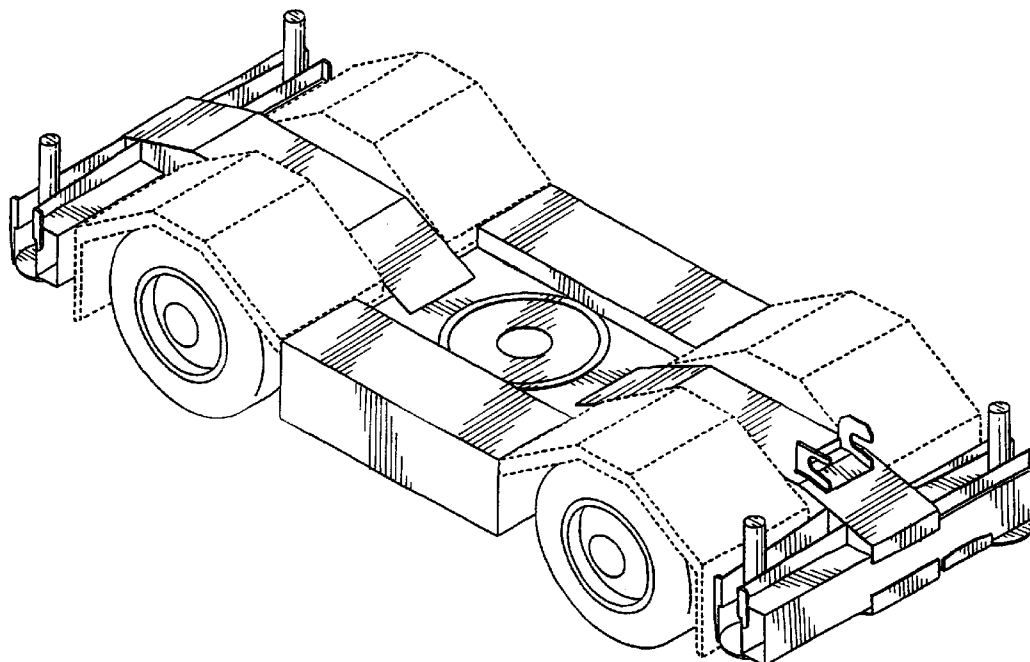

*FIG. 7*

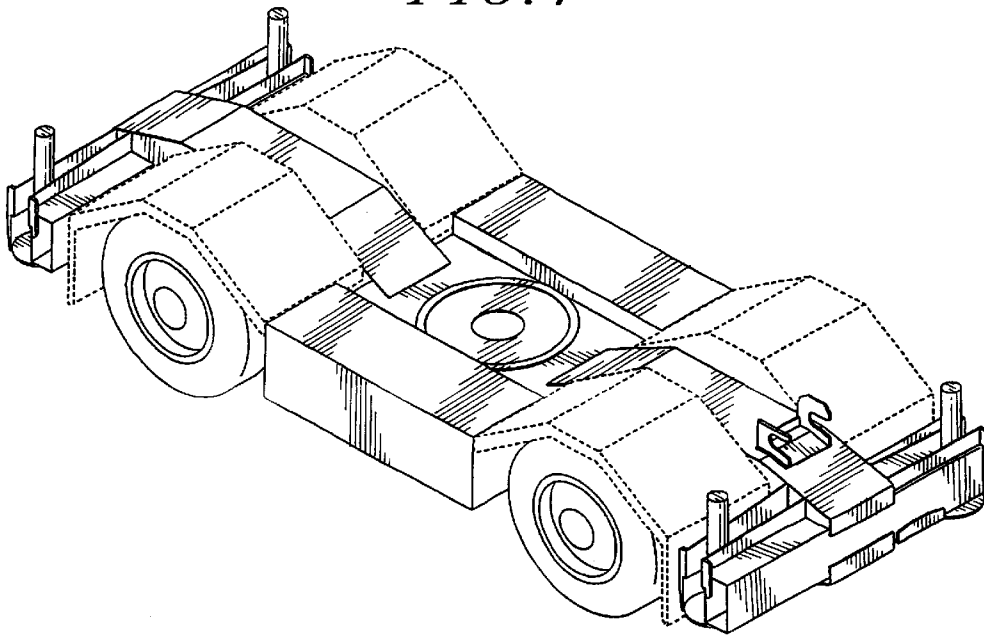

8.↙

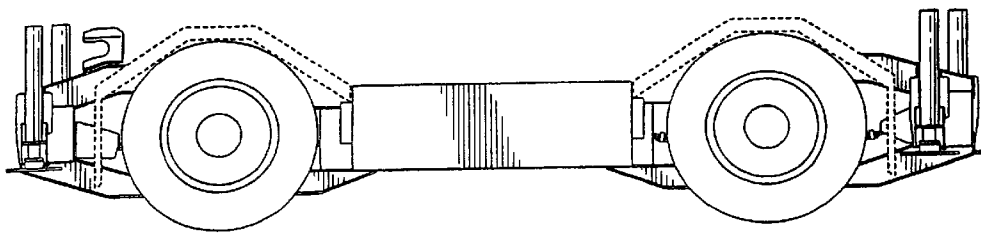

8.↙

*FIG. 1*

*FIG. 2*

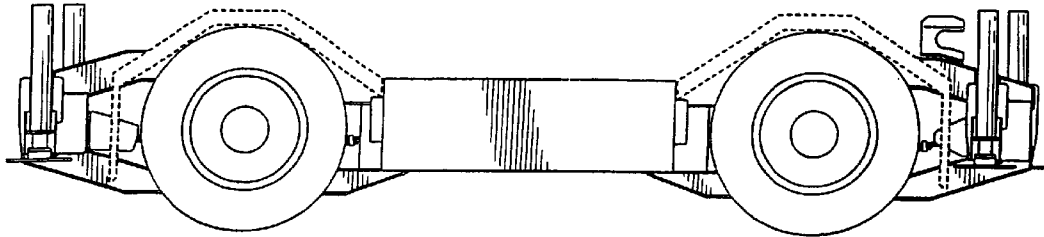

*FIG. 3*

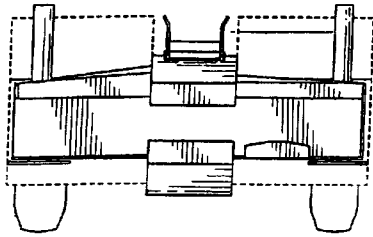

*FIG. 4*

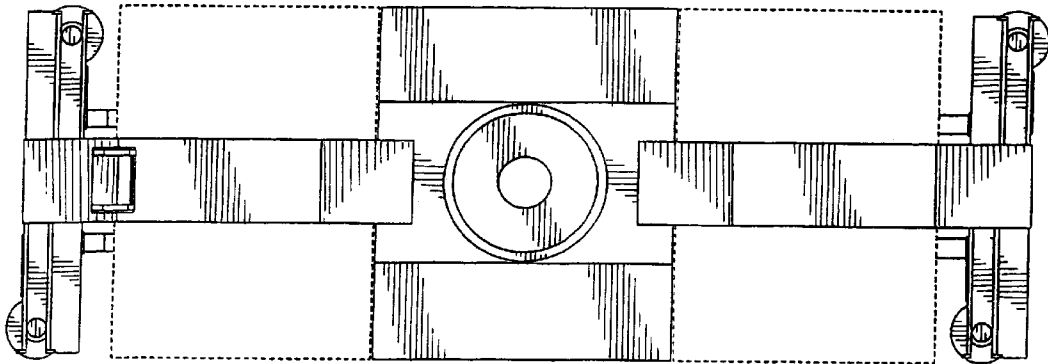
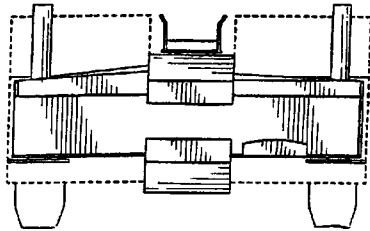

*FIG. 5*

FIG. 6

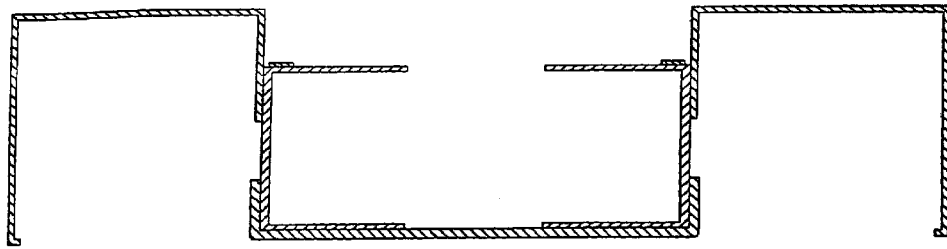
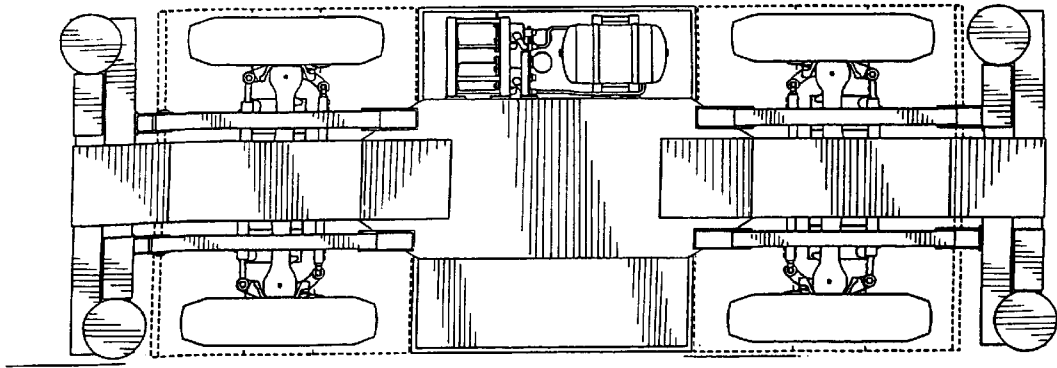

FIG. 8